

**HONDA**

**Power**

**Equipment**

# Owner's Manual

## EM5000SX

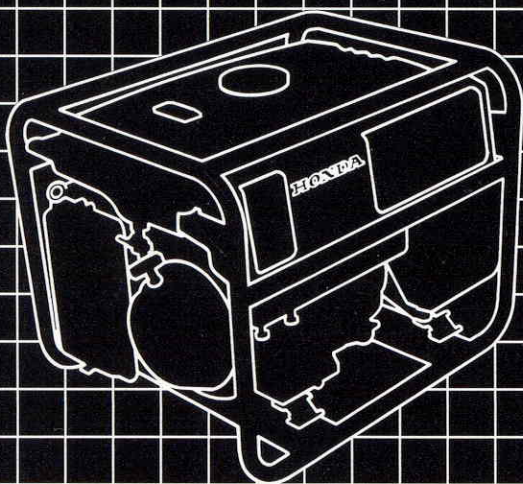

**⚠ WARNING**

**The generator is a potential source of electrical shock if misused. Do not expose the generator to moisture, rain or snow. Do not let the generator get wet, and do not operate it with wet hands.**



**WARNING:**



The engine exhaust from this product contains chemicals known to the State of California to cause cancer, birth defects or other reproductive harm.

---

Thank you for purchasing a Honda generator. We want to help you get the best results from your new generator and to operate it safely. This manual contains the information on how to do that; please read it carefully.

This owner's manual describes the operation and maintenance of the Honda Generator: **EM5000SX**

All information in this publication is based on the latest product information available at the time of printing.

Honda Motor Co., Ltd. reserves the right to make changes at any time without notice and without incurring any obligation.

No part of this publication may be reproduced without written permission.

This manual should be considered a permanent part of the generator and should remain with it if it is resold.

### **Safety Messages**

Your safety and the safety of others is very important. We have provided important safety messages in this manual and on the generator. Please read these messages carefully.

A safety message alerts you to potential hazards that could hurt you or others. Each safety message is preceded by a safety alert symbol  and one of three words: DANGER, WARNING, or CAUTION.

These mean:

 **DANGER** You **WILL** be **KILLED** or **SERIOUSLY HURT** if you don't follow instructions.

 **WARNING** You **CAN** be **KILLED** or **SERIOUSLY HURT** if you don't follow instructions.

 **CAUTION** You **CAN** be **HURT** if you don't follow instructions.

Each message tells you what the hazard is, what can happen, and what you can do to avoid or reduce injury.

### **Damage Prevention Messages**

You will also see other important messages that are preceded by the word NOTICE.

This word means:

 **NOTICE** Your generator or other property could be damaged if you don't follow instructions.

The purpose of these messages is to help prevent damage to your generator, other property, or the environment.

# CONTENTS

---

SAFETY .....	4
Safety Label Locations .....	4
Safety Information .....	6
COMPONENT IDENTIFICATION .....	8
CONTROLS .....	10
Engine Switch .....	10
Recoil Starter .....	10
Fuel Valve .....	11
Choke Rod .....	11
Circuit Breaker .....	12
Ground Terminal .....	12
Oil Alert System .....	12
Auto-throttle System .....	13
Volt Meter .....	14
Pilot Lamp .....	14
Voltage Selector Switch (Dual Voltage System) .....	14
DC Terminals .....	15
DC Circuit Protector .....	15
GENERATOR USE .....	16
Connections to a Building's Electrical System .....	16
Generator Ground Circuits .....	16
AC Applications .....	17
AC Operation .....	18
AC Receptacle Selection .....	19
DC Operation .....	20
Disconnecting the battery cables .....	21
Auto-throttle System .....	22
High Altitude Operation .....	23
PRE-OPERATION CHECK .....	24
Engine Oil .....	24
Fuel Recommendation .....	25
STARTING THE ENGINE .....	28
STOPPING THE ENGINE .....	29

---

MAINTENANCE .....	30
The Importance of Maintenance .....	30
Maintenance Safety .....	31
Emission Control System .....	32
Maintenance Schedule .....	35
Engine Oil Change .....	36
Air Cleaner Service .....	37
Fuel Sediment Cup Cleaning .....	38
Spark Plug Service .....	39
Spark Arrester Maintenance .....	40
TRANSPORTING/STORAGE .....	41
TROUBLESHOOTING .....	43
WIRING DIAGRAM .....	45
SPECIFICATIONS .....	46
INSTALLATION OF OPTIONAL PARTS .....	47
WARRANTY SERVICE INFORMATION .....	53
INDEX .....	54

# SAFETY

## SAFETY LABEL LOCATIONS

These labels warn you of potential hazards that can cause serious injury.

Read them carefully.

If a label comes off or becomes hard to read, contact your Honda Generator dealer for a replacement.

**WARNING**  
USING THE GENERATOR IN RAIN, SNOW OR NEAR WATER CAN LEAD TO DEATH FROM ELECTRIC SHOCK. KEEP GENERATOR DRY.



■CHECK FOR SPILLED FUEL OR FUEL LEAKS.  
STOP ENGINE BEFORE REFUELING.  
■CONTROLLER QU'IL N'Y A NI FUITE NI ESSENCE  
RÉPANDUE SUR L'APPAREIL.  
■ARRÊTER LE MOTEUR AVANT DE RÉFIRE LE PLEIN.  
■INSPECCIONAR PARA COMBUSTIBLE DERRAMADO  
O ESCAPE.  
■PARAR MOTOR ANTES DE ECHAR.

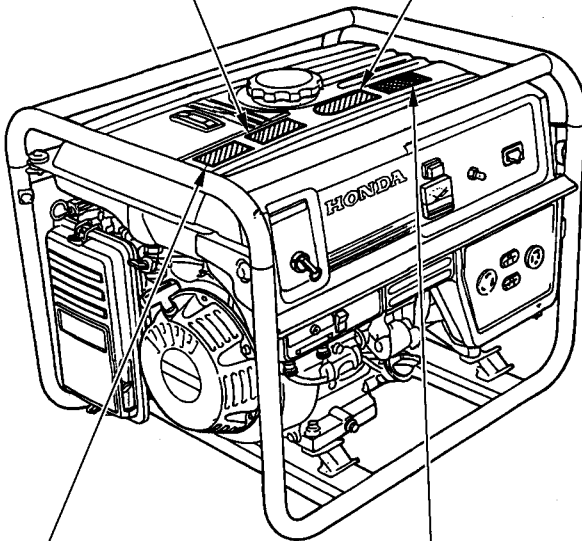

**WARNING**  
ELECTROCUTION OR PROPERTY DAMAGE CAN OCCUR. DO NOT CONNECT THIS GENERATOR TO ANY BUILDING'S ELECTRICAL SYSTEM UNLESS AN ISOLATION SWITCH HAS BEEN INSTALLED BY A LICENSED ELECTRICIAN. READ OWNER'S MANUAL CAREFULLY.

**WARNING** DO NOT USE INDOORS. EXHAUST GAS CONTAINS POISONOUS CARBON MONOXIDE.

**ATTENTION** NE PAS UTILISER DANS UN ENDROIT FERME A CAUSE DU RISQUE D'EMPOISONNEMENT DU GAZ.

**ATENCION** NO LO USE EN LUGARES CERRADOS PORQUE EL MONOXIDE DE CARBONO ES VENENOSO.

**EM5000SX**

HONDA MOTOR CO., LTD.

MADE IN JAPAN (A)

**CAUTION**

■ BE SURE TO FILL CRANKCASE  
WITH RECOMMENDED OIL  
BEFORE USING.  
FOR DETAILED EXPLANATION,  
SEE THE OWNER'S MANUAL.

**AC**

VOLTAGE 120/240V  
FREQUENCY 60Hz  
RATED OUTPUT 4.5kVA  
MAX. OUTPUT 5.0kVA  
PHASE 1Ø

**DC**

VOLTAGE 12V  
CURRENT 8.3A

FUEL GASOLINE  
(PETROL)

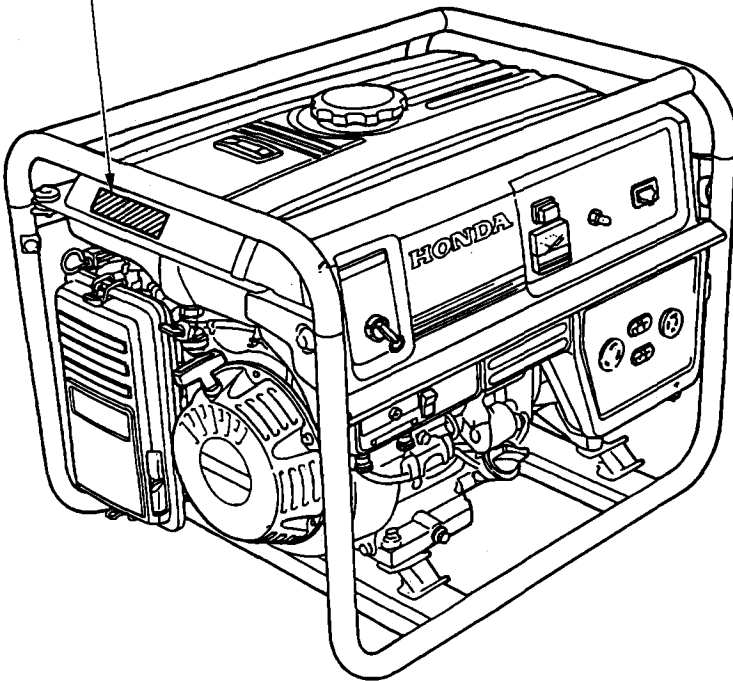

---

## **SAFETY INFORMATION**

Honda generators are designed to give safe and dependable service if operated according to instructions. Read and understand this owner's manual before operating your generator. You can help prevent accidents by being familiar with your generator's controls, and by observing safe operating procedures.

### **Operator Responsibility**

- Know how to stop the generator quickly in case of emergency.
- Understand the use of all generator controls, output receptacles, and connections.
- Be sure that anyone who operates the generator receives proper instruction. Do not let children operate the generator without parental supervision.

### **Carbon Monoxide Hazards**

- Exhaust contains poisonous carbon monoxide, a colorless and odorless gas. Breathing exhaust can cause loss of consciousness and may lead to death.
- If you run the generator in an area that is confined, or even partially enclosed, the air you breathe could contain a dangerous amount of exhaust gas. To keep exhaust gas from building up, provide adequate ventilation.

### **Electric Shock Hazards**

- The generator produces enough electric power to cause a serious shock or electrocution if misused.
- Using a generator or electrical appliance in wet conditions, such as rain or snow, or near a pool or sprinkler system, or when your hands are wet, could result in electrocution. Keep the generator dry.
- If the generator is stored outdoors, unprotected from the weather, check all electrical components on the control panel, before each use. Moisture or ice can cause a malfunction or short circuit in electrical components which could result in electrocution.
- Do not connect to a building's electrical system unless an isolation switch has been installed by a qualified electrician.



---

## **Fire and Burn Hazards**

- The exhaust system gets hot enough to ignite some materials.
  - Keep the generator at least 1 meter (3 feet) away from buildings and other equipment during operation.
  - Do not enclose the generator in any structure.
  - Keep flammable materials away from the generator.
- The muffler becomes very hot during operation and remains hot for a while after stopping the engine. Be careful not to touch the muffler while it is hot. Let the engine cool before storing the generator indoors.
- Gasoline is extremely flammable and is explosive under certain conditions. Do not smoke or allow flames or sparks where the generator is refueled or where gasoline is stored. Refuel in a well-ventilated area with the engine stopped.
- Fuel vapors are extremely flammable and may ignite after the engine has started. Make sure that any spilled fuel has been wiped up before starting the generator.

# COMPONENT IDENTIFICATION

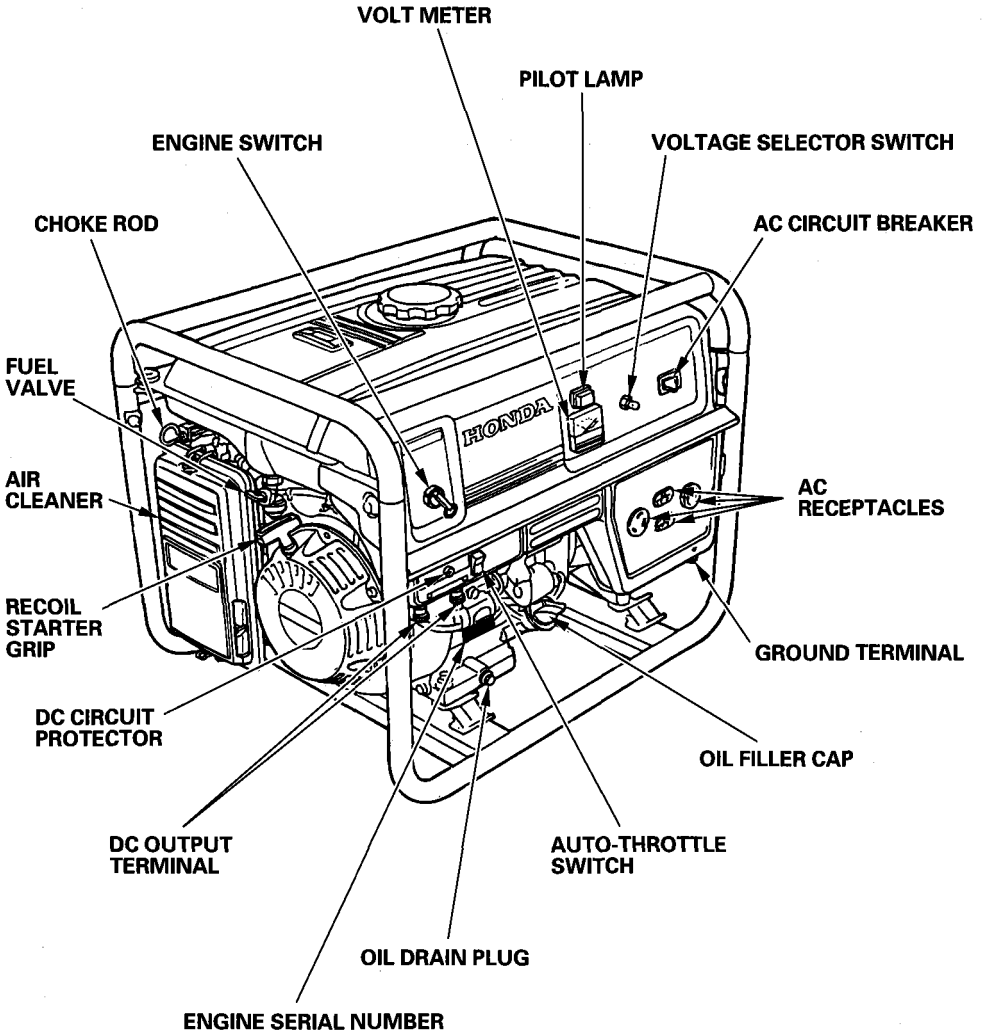

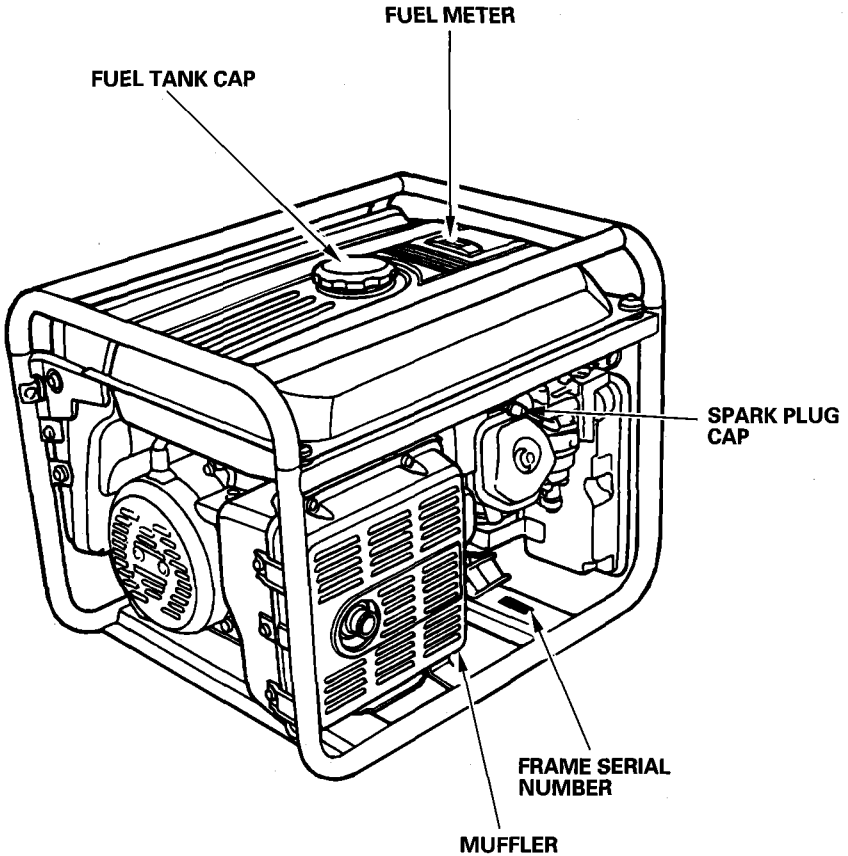

\*Record the engine and frame serial numbers for your future reference. Refer to these serial numbers when ordering parts, and when making technical or warranty inquiries (see page 53 ).

Frame serial number: \_\_\_\_\_

Engine serial number: \_\_\_\_\_

# CONTROLS

---

## Engine Switch

To start and stop the engine.

### Key position:

**OFF:** To stop the engine. Key can be removed/inserted.

**ON:** To run the engine after starting.

**START:** To start the engine by operating the starter motor.

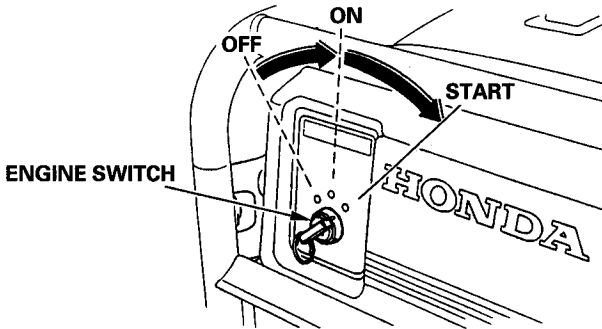

Return the key to the ON position once the engine has started. Do not use the starter for more than 5 seconds at a time. If the engine fails to start, release the switch and wait 10 seconds before operating the starter again.

## Recoil Starter

To start the engine, pull the starter grip lightly until resistance is felt, then pull briskly.

### NOTICE

**Do not allow the starter grip to snap back against the engine. Return it gently to prevent damage to the starter.**

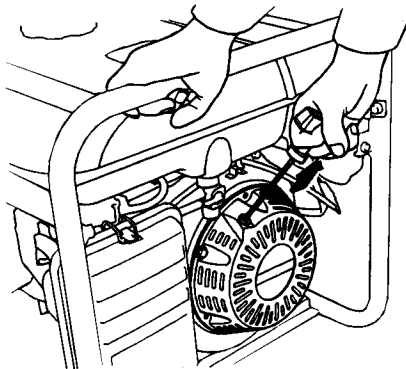

---

## Fuel Valve

The fuel valve is located between the fuel tank and carburetor. When the valve lever is in the ON position, fuel is allowed to flow from the fuel tank to the carburetor. Be sure to return the lever to the OFF position after stopping the engine.

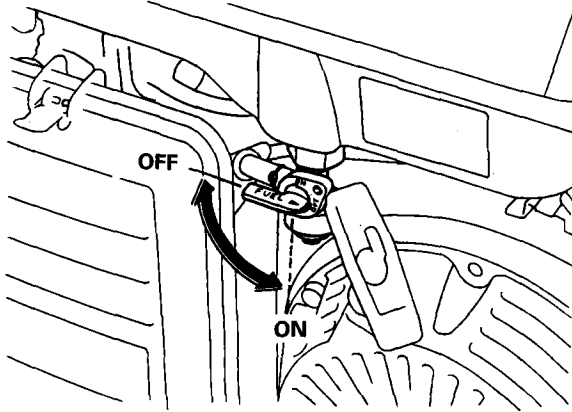

## Choke Rod

The choke is used to provide proper starting mixture when the engine is cold. It can be opened and closed by operating the choke rod manually. Pull the rod out toward CLOSED to enrich the mixture for cold starting.

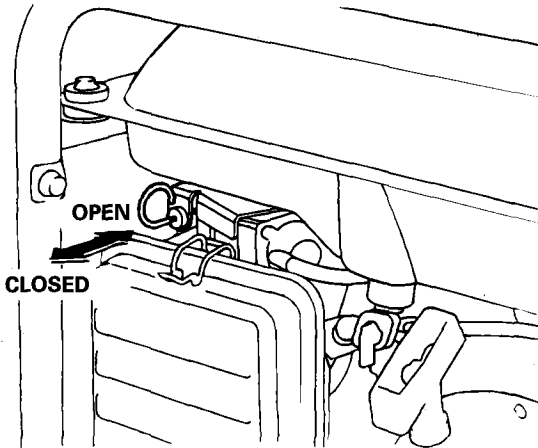

## Circuit Breaker

The circuit breaker will automatically switch OFF if there is a short circuit or a significant overload of the generator at the receptacle. If the circuit breaker is switched OFF automatically, check that the appliance is working properly and does not exceed the rated load capacity of the circuit before switching the circuit breaker ON again.

The circuit breaker may be used to switch the generator power on or off.

## Ground Terminal

The generator ground terminal is connected to the frame of the generator, the metal non-current-carrying parts of the generator, and the ground terminals of each receptacle.

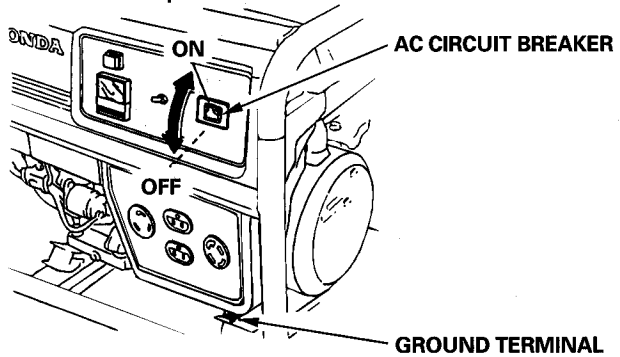

## Oil Alert System

The Oil Alert system is designed to prevent engine damage caused by an insufficient amount of oil in the crankcase. Before the oil level in the crankcase can fall below a safe limit, the Oil Alert system will automatically stop the engine (the engine switch will remain in the ON position).

If the engine stops and will not restart, check the engine oil level (see page 24 ) before troubleshooting in other areas.

OIL FILLER HOLE

OIL FILLER CAP

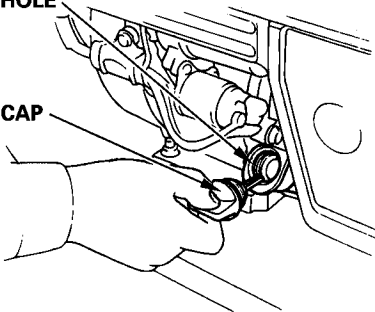

UPPER LEVEL

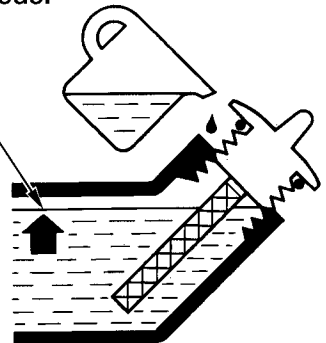

---

## Auto-throttle System

The auto-throttle system automatically reduces engine speed when all loads are turned off or disconnected. When appliances are turned on or reconnected, the engine returns to the rated speed.

**AUTO:** Recommended to minimize fuel consumption and further reduce noise levels when no load is applied to the generator.

**OFF:** The auto-throttle system does not operate.

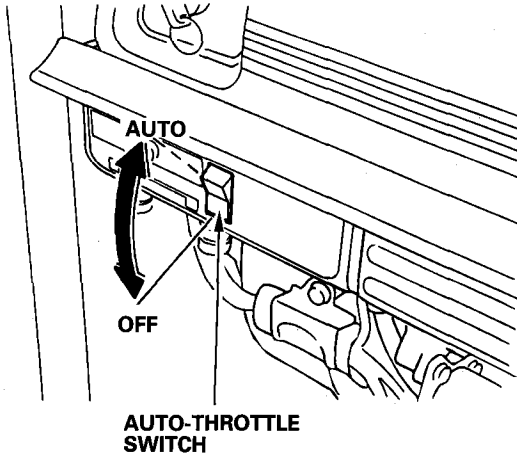

## Pilot Lamp

The pilot lamp is illuminated when the generator is operating normally. It indicates that the generator is producing electrical power at the 120 or 120/240 volt receptacles. If the pilot light is illuminated, the volt meter should be displaying 120 or 240 volts depending on the position of the voltage selector switch.

When the auto-throttle is in the AUTO position, and there is no load connected to the generator, the engine will run slower and the pilot light will be dimmer than at normal operating speed.

## Volt Meter

The volt meter displays the voltage the generator is producing depending on the position of the voltage selector switch. If the voltage selector switch is in the "120/240V" position, the volt meter will display 240 volts. If the voltage selector switch is in the "120V ONLY" position, the volt meter will display 120 volts.

## Voltage Selector Switch (Dual Voltage System)

The voltage selector switches the main power carrying windings of the generator to produce "120V ONLY" or "120/240V". If a 240V appliance is connected to the 4-prong receptacle, the switch must be in the "120/240V" position. If a 120V appliance ONLY is being connected to any of the 120V 3-prong receptacles, select the "120V ONLY" position.

**120/240V:** The 120V and 120/240V receptacles can be used simultaneously.

**120V ONLY:** ONLY the 120V receptacles can be used. Do not use the 120/240V receptacle in this position. Rated power will be available at the 120V twist lock receptacle.

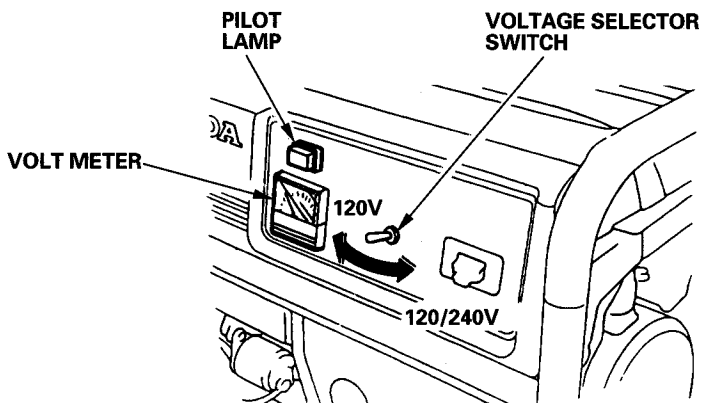



---

## DC Terminals

The DC terminals may ONLY be used for charging 12 volt automotive type batteries.

The terminals are colored red to identify the positive (+) terminal and black to identify the negative (-) terminal. The battery must be connected to the generator DC terminals with the proper polarity (battery positive to generator red terminal and battery negative to the generator black terminal).

## DC Circuit Protector

The DC circuit protector automatically shuts off the DC battery charging circuit when the DC charging circuit is overloaded, when there is a problem with the battery, or when the connections between the battery and the generator are improper.

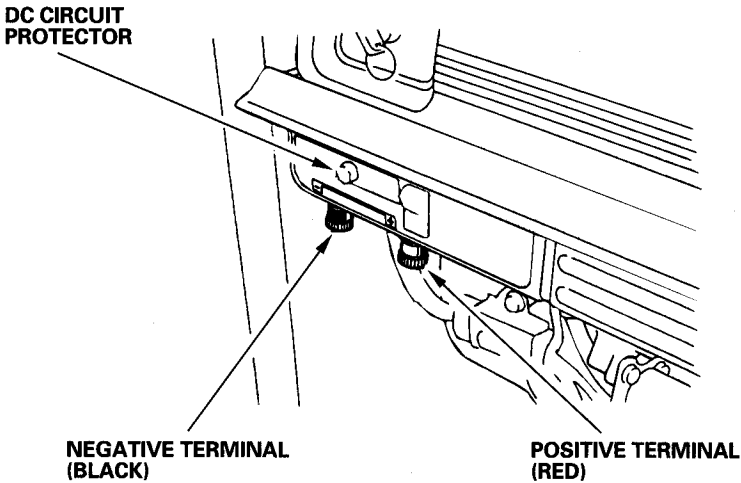

# GENERATOR USE

---

## Connections to a Building's Electrical System

Connections for standby power to a building's electrical system must be made by a qualified electrician. The connection must isolate the generator power from utility power, and must comply with all applicable laws and electrical codes.

### **▲WARNING**

**Improper connections to a building's electrical system can allow electrical current from the generator to backfeed into the utility lines. Such backfeed may electrocute utility company workers or others who contact the lines during a power outage. Consult the utility company or a qualified electrician.**

### **NOTICE**

**Improper connections to a building's electrical system can allow electrical current from the utility company to backfeed into the generator. When utility power is restored, the generator may explode, burn, or cause fires in the building's electrical system.**

In some areas, generators are required by law to be registered with local utility companies. Check local regulations for proper registration and use procedures.

## Ground System

Honda portable generators have a system ground that connects generator frame components to the ground terminals in the AC output receptacles. The system ground is not connected to the AC neutral wire. If the generator is tested by a receptacle tester, it will not show the same ground circuit condition as for a home receptacle.

## Special Requirements

There may be Federal or State Occupational Safety and Health Administration (OSHA) regulations, local codes, or ordinances that apply to the intended use of the generator. Please consult a qualified electrician, electrical inspector, or the local agency having jurisdiction.

- In some areas, generators are required to be registered with local utility companies.
- If the generator is used at a construction site, there may be additional regulations which must be observed.

---

## AC Applications

Before connecting an appliance or power cord to the generator:

- Make sure that it is in good working order. Faulty appliances or power cords can create a potential for electrical shock.
- If an appliance begins to operate abnormally, becomes sluggish or stops suddenly, turn it off immediately. Disconnect the appliance, and determine whether the problem is the appliance, or if the rated load capacity of the generator has been exceeded.
- Make sure that the electrical rating of the tool or appliance does not exceed that of the generator. Never exceed the maximum power rating of the generator. Power levels between rated and maximum may be used for no more than 30 minutes.

**NOTICE**

**Substantial overloading will open the circuit breaker. Exceeding the time limit for maximum power operation or slightly overloading the generator may not switch the circuit breaker OFF, but will shorten the service life of the generator.**

Limit operation requiring maximum power to 30 minutes.

Maximum power is:

5.0 kVA

For continuous operation, do not exceed the rated power.

Rated power is:

4.5 kVA

In either case, the total power requirements (VA) of all appliances connected must be considered. Appliance and power tool manufacturers usually list rating information near the model number or serial number.

---

## AC Operation

1. Start the engine (see page 28 ).
2. Turn the voltage selector switch to either position.

With the voltage selector switch in the "120/240V" position, you can use the 120V and 120/240V receptacles simultaneously. If you are NOT using the 120/240V receptacle, but require more power from the 120V locking plug receptacle, then select the "120V ONLY" position.

3. Switch ON the AC circuit breaker.
  4. Plug in the appliance.
- Most motorized appliances require more than their rated wattage for startup.

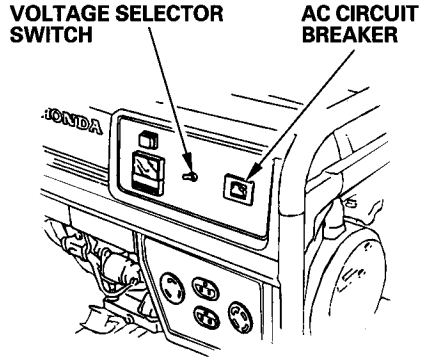

Do not exceed the current limit specified for any one receptacle. If an overloaded circuit causes the AC circuit breaker or circuit protector to switch OFF, reduce the electrical load on the circuit, wait a few minutes and then reset the circuit breaker.

## AC Receptacle Selection

The generator has two separate main power producing circuits. These two circuits supply equal power to different receptacles shown when the voltage selector switch is in the 120/240V position.

When two or more receptacles are used; prevent overloading by dividing the load between the two power circuits.

The chart below shows the rated load in amperes that can be connected to each receptacle to balance the generator.

The total rated ampere draw is 37.5A.

Main power circuit	Receptacles powered by each main circuit	Power distribution
Main Circuit I	1 and 5	1 + 5 = 18.8A rated.
Main Circuit II	2, 3 and 4	2 + 3 + 4 = 18.8A rated.

\* The table shows the specifications when the 120/240V locking plug receptacle is used for 120V.

Example:

Receptacle 3 has a 15A load connected to it. Receptacle 2 has a 10 A load connected to it. Both receptacles are powered by main power circuit II. The equation tells us that the total power draw on circuit II is 25A. This is a substantial overload of this circuit. To eliminate the excess power draw on circuit II, the load from receptacle 2 should be switched to receptacle 1. Now circuit I is powering the 10A load (less than 18.8A) and circuit II is powering the 15A load (less than 18.8A).

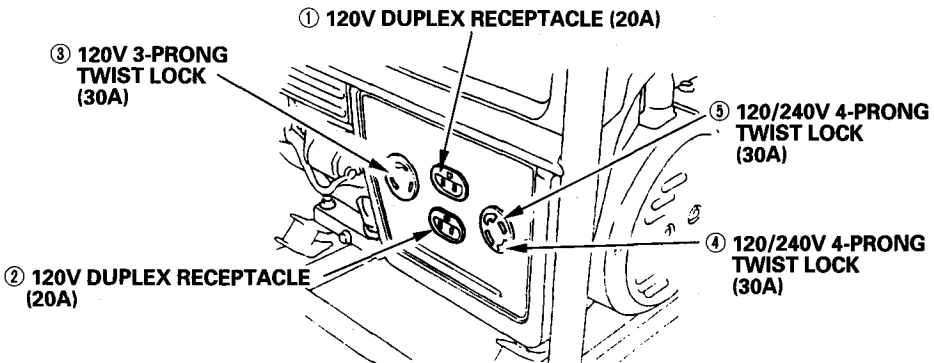

## DC Operation

The DC terminals may **ONLY** be used for charging 12 volt automotive type batteries.

### Connecting the battery cables:

1. Before connecting charging cables to a battery that is installed in a vehicle, disconnect the vehicle's grounded battery cable.

#### **⚠ WARNING**

**The battery gives off explosive gases; keep sparks, flames and cigarettes away. Provide adequate ventilation when charging or using batteries.**

2. Connect the positive (+) battery cable to the battery positive (+) terminal.
3. Connect the other end of the positive (+) battery cable to the generator positive (+) terminal.

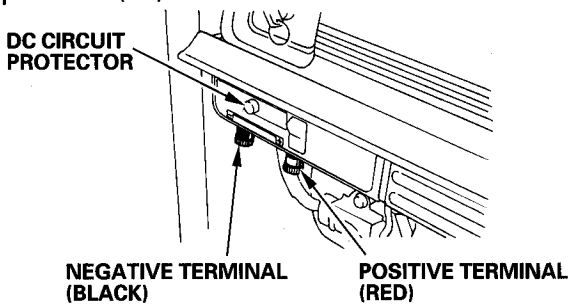

4. Connect the negative (-) battery cable to the battery negative (-) terminal.
5. Connect the other end of the negative (-) battery cable to the generator negative (-) terminal.
6. Start the generator.

#### **NOTICE**

**Do not start the vehicle while the battery charging cables are connected and the generator is running. The vehicle or the generator may be damaged.**

An overloaded DC circuit, excessive current draw by the battery, or a wiring problem will trip the DC circuit protector (PUSH button extends out). If this happens, wait a few minutes before pushing in the circuit protector to resume operation. If the circuit protector continues to go OFF, discontinue charging and see your authorized Honda generator dealer.

---

### Disconnecting the battery cables:

1. Stop the engine.
2. Disconnect the negative (-) battery cable from the generator negative (-) terminal.
3. Disconnect the other end of the negative (-) battery cable from the battery negative (-) terminal.
4. Disconnect the positive (+) battery cable from the generator positive (+) terminal.
5. Disconnect the other end of the positive (+) battery cable from the battery positive (+) terminal.
6. Connect the vehicle ground cable to the battery negative (-) terminal.

DC CIRCUIT  
PROTECTOR

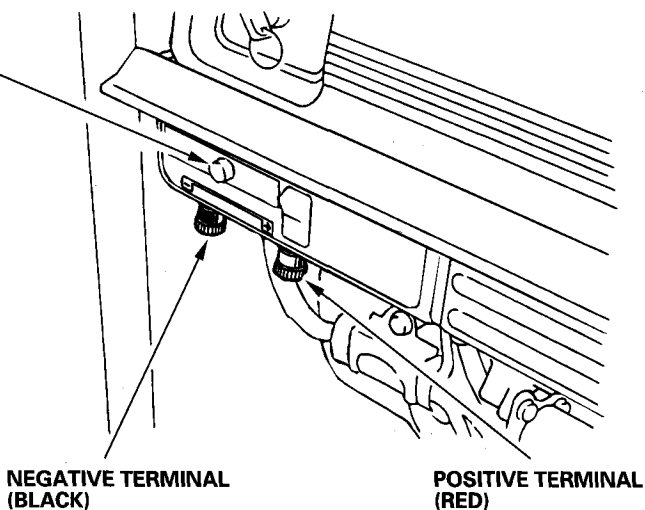

NEGATIVE TERMINAL  
(BLACK)

POSITIVE TERMINAL  
(RED)

---

## Auto-throttle System

With the switch in the AUTO position, engine speed is automatically reduced when ALL loads are turned OFF or disconnected. When appliances are turned ON or reconnected, the engine returns to rated speed. In the OFF position, the auto-throttle system does not operate.

The auto-throttle system will not respond to electrical loads of less than 1 ampere. Turn the auto-throttle to the OFF position to operate loads of less than 1 amp.

Appliances with large start-up power demands may not allow the engine to reach normal operating rpm when they are connected to the generator. Turn the auto-throttle to the OFF position and connect the appliance to the generator. If the engine still will not reach normal operating speed, check that the appliance does not exceed the rated load capacity of the generator.

To avoid extended warm-up periods, keep the switch OFF until the engine reaches operating temperature.

The auto-throttle system is not effective for use with appliances that require only momentary power. If the tool or appliance will be turned ON and OFF quickly, the auto-throttle switch should be in the OFF position.

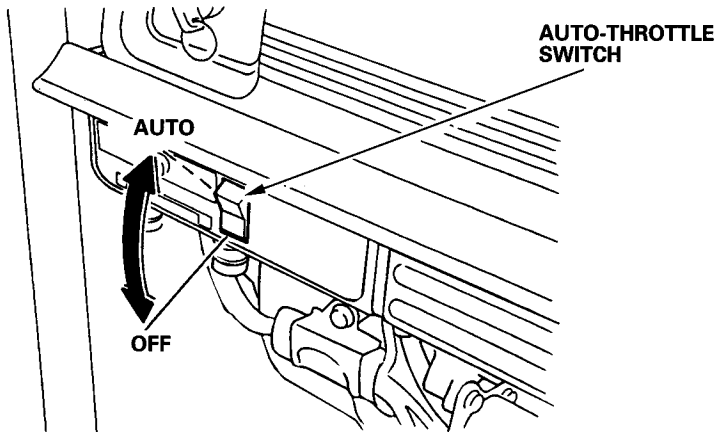



---

## High Altitude Operation

At high altitude, the standard carburetor air-fuel mixture will be too rich. Performance will decrease, and fuel consumption will increase. A very rich mixture will also foul the spark plug and cause hard starting.

High altitude performance can be improved by specific modifications to the carburetor. If you always operate your engine at altitudes above 1,800 meters (6,000 feet), have your dealer perform this carburetor modification.

Even with carburetor modification, engine horsepower will decrease about 3.5% for each 300 meter (1,000 foot) increase in altitude. The effect of altitude on horsepower will be greater than this if no carburetor modification is made.

### NOTICE

**When the carburetor has been modified for high altitude operation, the air-fuel mixture will be too lean for low altitude use. Operation at altitudes below 1,800 meters (6,000 feet) with a modified carburetor may cause the engine to overheat and result in serious engine damage. For use at low altitudes, have your dealer return the carburetor to original factory specifications.**

# PRE-OPERATION CHECK

## Engine Oil

### NOTICE

Engine oil is a major factor affecting engine performance and service life. Non-detergent and 2-stroke engine oils will damage the engine and are not recommended.

Check the oil level BEFORE EACH USE with the generator on a level surface and the engine stopped.

Use 4-stroke motor oil that meets or exceeds the requirements for API service classification SF or SG. Always check the API SERVICE label on the oil container to be sure it includes the letters SF or SG.

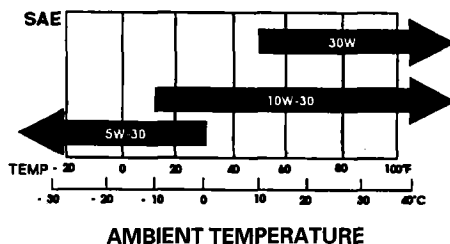

SAE 10W-30 is recommended for general, all-temperature use. Other viscosities shown in the chart may be used when the average temperature in your area is within the indicated range.

1. Remove the oil filler cap and wipe the dipstick clean.
2. Check the oil level by inserting the dipstick into the filler neck without screwing it in.
3. If the level is low, add the recommended oil to the upper mark on the dipstick. Over filling with oil can cause the engine to smoke after start-up.

OIL FILLER HOLE

OIL FILLER CAP

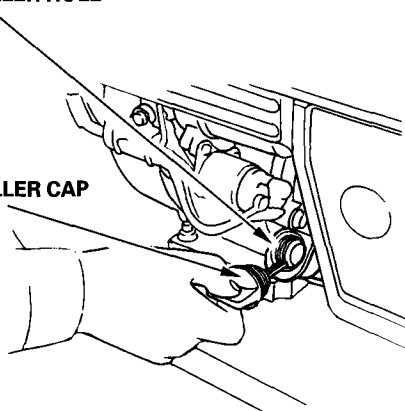

UPPER LEVEL

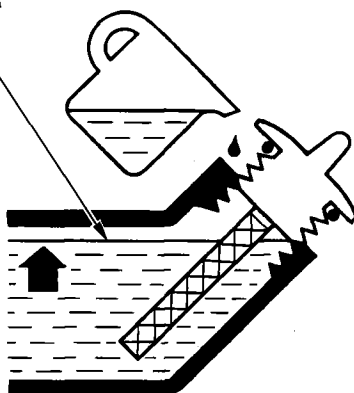

---

## Fuel Recommendation

1. Check the fuel level gauge.
2. Refill the tank if the fuel level is low. Do not fill above the shoulder of the fuel strainer.

### **▲WARNING**

- **Gasoline is extremely flammable and is explosive under certain conditions.**
- **Refuel in a well-ventilated area with the engine stopped. Do not smoke or allow flames or sparks in the area where the engine is refueled or where gasoline is stored.**
- **Do not overfill the fuel tank (there should be no fuel in the filler neck). After refueling, make sure the tank cap is closed properly and securely.**  
**Be careful not to spill fuel when refueling. Spilled fuel or fuel vapor may ignite. If any fuel is spilled, make sure the area is dry before starting the engine.**
- **Avoid repeated or prolonged contact with skin or breathing of vapor.**
- **KEEP OUT OF REACH OF CHILDREN.**

**Fuel tank capacity:** 17.0 l (4.49 US gal , 3.74 Imp gal)

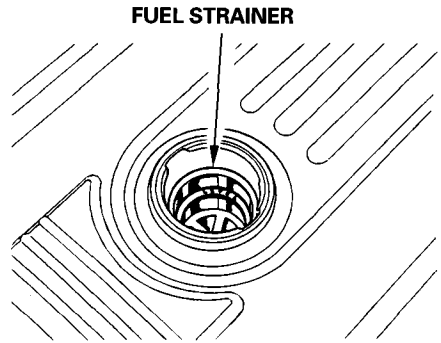
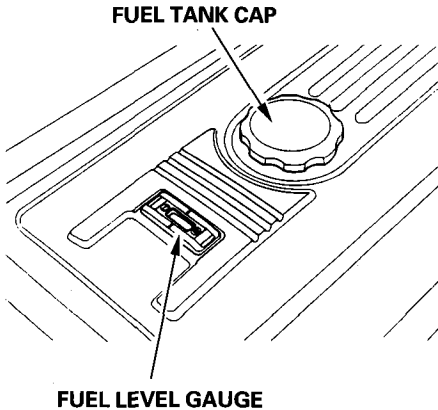

Use unleaded gasoline with a pump octane rating of 86 or higher. This engine is certified to operate on unleaded gasoline. Unleaded gasoline produces fewer engine and spark plug deposits and extends exhaust system life.

Never use stale or contaminated gasoline or oil/gasoline mixture. Avoid getting dirt or water in the fuel tank.

---

Occasionally you may hear light "spark knock" or "pinging" (metallic rapping noise) while operating under heavy loads. This is no cause for concern.

If spark knock or pinging occurs at a steady engine speed, under normal load, change brands of gasoline. If spark knock or pinging persists, see an authorized Honda generator dealer.

**NOTICE**

**Running the engine with persistent spark knock or pinging can cause engine damage.**

Running the engine with persistent spark knock or pinging is misuse, and the Distributor's Limited Warranty does not cover parts damaged by misuse.

---

## Oxygenated Fuels

Some conventional gasolines are being blended with alcohol or an ether compound. These gasolines are collectively referred to as oxygenated fuels. To meet clean air standards, some areas of the United States and Canada use oxygenated fuels to help reduce emissions.

If you use an oxygenated fuel, be sure it is unleaded and meets the minimum octane rating requirement.

Before using an oxygenated fuel, try to confirm the fuel's contents. Some states/provinces require this information to be posted on the pump.

The following are the EPA approved percentages of oxygenates:

**ETHANOL** — (ethyl or grain alcohol) 10% by volume  
You may use gasoline containing up to 10% ethanol by volume. Gasoline containing ethanol may be marketed under the name "Gasohol".

**MTBE** — (methyl tertiary butyl ether) 15% by volume  
You may use gasoline containing up to 15% MTBE by volume.

**METHANOL** — (methyl or wood alcohol) 5% by volume  
You may use gasoline containing up to 5% methanol by volume as long as it also contains cosolvents and corrosion inhibitors to protect the fuel system. Gasoline containing more than 5% methanol by volume may cause starting and/or performance problems. It may also damage metal, rubber, and plastic parts of your fuel system.

If you notice any undesirable operating symptoms, try another service station or switch to another brand of gasoline.

Fuel system damage or performance problems resulting from the use of an oxygenated fuel containing more than the percentages of oxygenates mentioned above are not covered under warranty.

# STARTING THE ENGINE

---

1. Make sure that the AC circuit breaker is in the OFF position. The generator may be hard to start if a load is connected.
2. Turn the fuel valve to the ON position.
3. The automatic choke will be closed if the engine is cold. If you want to operate the choke manually, pull the choke rod out to the CLOSED position.
4. Make sure the auto-throttle switch is in the OFF position, or more time will be required for warm up.
5. Start the engine
  - With recoil starter:  
Turn the engine switch to the ON position.

Pull the starter grip lightly until resistance is felt, then pull briskly.

## NOTICE

**Do not allow the starter grip to snap back against the engine. Return it gently to prevent damage to the starter or housing.**

- With electric starter: (Optional kit)  
Turn the engine switch to the START position and hold it there for 5 seconds or until the engine starts.

## NOTICE

- **Operating the starter motor for more than 5 seconds can damage the motor. If the engine fails to start, release the switch and wait 10 seconds before operating the starter again.**
- **If the speed of the starter motor drops after a period of time, it is an indication that the battery should be recharged.**

When the engine starts, allow the engine switch to return to the ON position.

6. If you have manually closed the choke, push it to the OPEN position as the engine warms up.
7. If you wish to use the auto-throttle system, turn the auto-throttle switch to the AUTO position after the engine has warmed up for 2 or 3 minutes.

# STOPPING THE ENGINE

---

## **In an emergency:**

1. To stop the engine in an emergency, turn the engine switch to the OFF position.

## **In normal use:**

1. Turn the AC circuit breaker to the OFF position.  
Disconnect DC battery charging cables.
2. Turn the engine switch to the OFF position.
3. Turn the fuel valve to the OFF position.

# MAINTENANCE

---

## The Importance of Maintenance

Good maintenance is essential for safe, economical, and trouble-free operation. It will also help reduce air pollution.

### **▲WARNING**

**Improper maintenance, or failure to correct a problem before operation, can cause a malfunction in which you can be seriously hurt or killed.**

**Always follow the inspection and maintenance recommendations and schedules in this owner's manual.**

To help you properly care for your generator, the following pages include a maintenance schedule, routine inspection procedures, and simple maintenance procedures using basic hand tools. Other service tasks that are more difficult, or require special tools, are best handled by professionals and are normally performed by a Honda technician or other qualified mechanic.

The maintenance schedule applies to normal operating conditions. If you operate your generator under severe conditions, such as sustained high-load or high-temperature operation, or use in unusually wet or dusty conditions, consult your servicing dealer for recommendations applicable to your individual needs and use.

**Maintenance, replacement, or repair of the emission control devices and systems may be performed by any engine repair establishment or individual, using parts that are "certified" to EPA standards.**



---

## Maintenance Safety

Some of the most important safety precautions follow. However, we cannot warn you of every conceivable hazard that can arise in performing maintenance. Only you can decide whether or not you should perform a given task.

### **▲WARNING**

**Failure to properly follow maintenance instructions and precautions can cause you to be seriously hurt or killed.**

**Always follow the procedures and precautions in the owner's manual.**

### Safety precautions

- Make sure the engine is off before you begin any maintenance or repairs. This will eliminate several potential hazards:
  - **Carbon monoxide poisoning from engine exhaust.**  
Be sure there is adequate ventilation whenever you operate the engine.
  - **Burns from hot parts.**  
Let the engine and exhaust system cool before touching.
  - **Injury from moving parts.**  
Do not run the engine unless instructed to do so.
- Read the instructions before you begin, and make sure you have the tools and skills required.
- To reduce the possibility of fire or explosion, be careful when working around gasoline. Use only a nonflammable solvent, not gasoline, to clean parts. Keep cigarettes, sparks, and flames away from all fuel-related parts.

Remember that your servicing dealer knows your generator best and is fully equipped to maintain and repair it.

To ensure the best quality and reliability, use only new, genuine Honda parts or their equivalents for repair or replacement.

---

## **Emission Control System**

### **Source of Emissions**

The combustion process produces carbon monoxide, oxides of nitrogen, and hydrocarbons. Control of hydrocarbons and oxides of nitrogen is very important because, under certain conditions, they react to form photochemical smog when subjected to sunlight. Carbon monoxide does not react in the same way, but it is toxic.

Honda utilizes lean carburetor settings and other systems to reduce the emissions of carbon monoxide, oxides of nitrogen, and hydrocarbons.

### **The U.S. and California Clean Air Acts**

EPA and California regulations require all manufacturers to furnish written instructions describing the operation and maintenance of emission control systems.

The following instructions and procedures must be followed in order to keep the emissions from your Honda engine within the emission standards.

### **Tampering and Altering**

Tampering with or altering the emission control system may increase emissions beyond the legal limit. Among those acts that constitute tampering are:

- Removal or alteration of any part of the intake, fuel, or exhaust systems.
- Altering or defeating the governor linkage or speed-adjusting mechanism to cause the engine to operate outside its design parameters.

---

## **Problems That May Affect Emissions**

If you are aware of any of the following symptoms, have your engine inspected and repaired by your servicing dealer.

- Hard starting or stalling after starting.
- Rough idle.
- Misfiring or backfiring under load.
- Afterburning (backfiring).
- Black exhaust smoke or high fuel consumption.

---

## **Replacement Parts**

The emission control systems on your Honda engine were designed, built, and certified to conform with EPA and California emission regulations. We recommend the use of genuine Honda parts whenever you have maintenance done. These original-design replacement parts are manufactured to the same standards as the original parts, so you can be confident of their performance. The use of replacement parts that are not of the original design and quality may impair the effectiveness of your emission control system.

A manufacturer of an aftermarket part assumes the responsibility that the part will not adversely affect emission performance. The manufacturer or rebuilder of the part must certify that use of the part will not result in a failure of the engine to comply with emission regulations.

## **Maintenance**

Follow the maintenance schedule on page 35 . Remember that this schedule is based on the assumption that your machine will be used for its designed purpose. Sustained high-load or high-temperature operation, or use in unusually wet or dusty conditions, will require more frequent service.

## Maintenance Schedule

REGULAR SERVICE PERIOD (3) ITEM Performed at every indicated month or operating hour interval, whichever comes first.		Each use	First month or 20 Hrs.	Every 3 months or 50 Hrs.	Every 6 months or 100 Hrs.	Every year or 300 Hrs.
• Engine oil	Check level					
	Change	○	○		○	
• Air cleaner	Check					
	Clean			○(1)		
• Sediment cup	Clean				○	
• Spark plug	Clean-Readjust				○	
	Replace					○
Spark arrester	Clean				○	
• Valve clearance	Check-Readjust					○(2)
• Fuel tank and filter	Clean					○(2)
• Fuel line	Check	Every 2 years (Replace if necessary)(2)				

**NOTE:** • Emission related items.

- (1) Service more frequently when used in dusty areas.
- (2) These items should be serviced by an authorized Honda generator dealer, unless the owner has the proper tools and is mechanically proficient. See the Honda Shop Manual.
- (3) For professional commercial use, log hours of operation to determine proper maintenance intervals.

---

## Engine Oil Change

Drain the oil while the engine is warm to assure rapid and complete draining.

1. Remove the drain plug and sealing washer, oil filler cap, and drain the oil.
2. Install the drain plug and sealing washer. Tighten the plug securely.
3. Refill with the recommended oil (see page 24 ) and check the oil level.

### Oil capacity:

1.1 ℓ (1.2 US qt , 1.0 Imp qt)

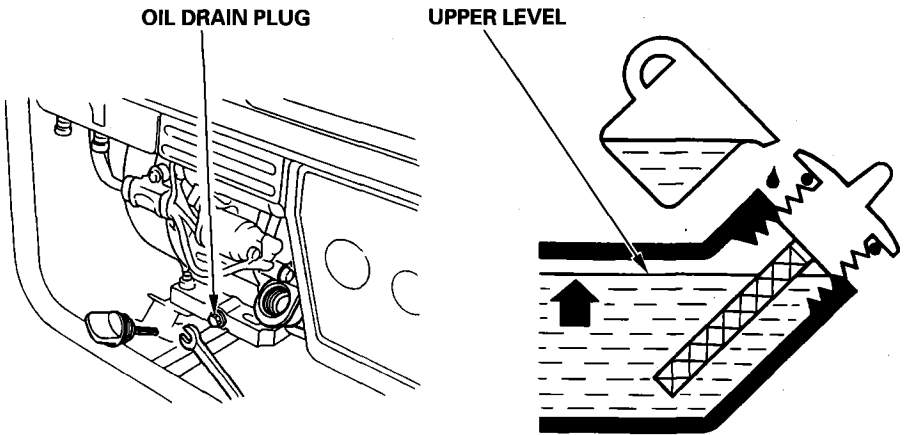

Wash your hands with soap and water after handling used oil.

Please dispose of used motor oil in a manner that is compatible with the environment. We suggest you take it in a sealed container to your local service station or recycling center for reclamation. Do not throw it in the trash, pour it on the ground, or down a drain.

## Air Cleaner Service

A dirty air cleaner will restrict air flow to the carburetor. To prevent carburetor malfunction, service the air cleaner regularly. Service more frequently when operating the generator in extremely dusty areas.

### ▲WARNING

Using gasoline or flammable solvent to clean the filter element can cause a fire or explosion. Use only soapy water or nonflammable solvent.

### NOTICE

Never run the generator without the air cleaner. Rapid engine wear will result.

1. Unsnap the air cleaner cover clips, remove the air cleaner cover, and remove the element.
2. Wash the element in a solution of household detergent and warm water, then rinse thoroughly, or wash in nonflammable or high flash point solvent. Allow the element to dry thoroughly.
3. Soak the element in clean engine oil and squeeze out the excess oil. The engine will smoke during initial start-up if too much oil is left in the element.
4. Reinstall the air cleaner element and the cover.

AIR CLEANER COVER

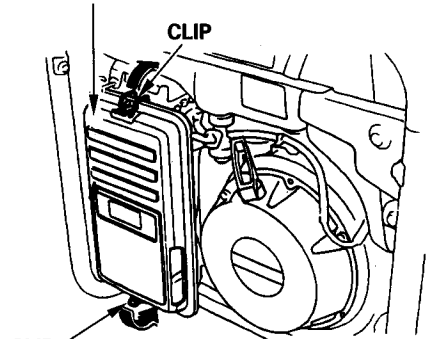

AIR CLEANER ELEMENT

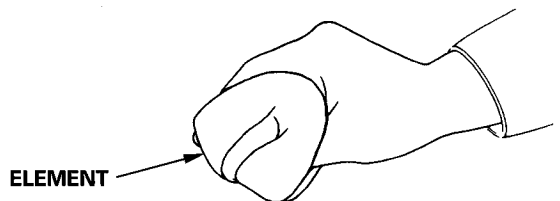
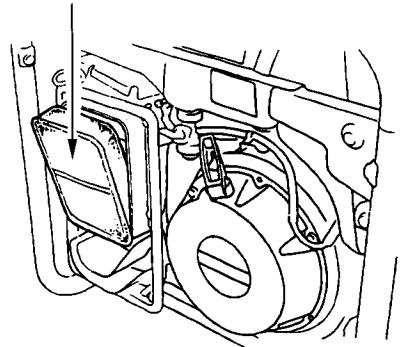

## Fuel Sediment Cup Cleaning

The sediment cup prevents dirt or water which may be in the fuel tank from entering the carburetor. If the engine has not been run for a long time, the sediment cup should be cleaned.

1. Turn the fuel valve to the OFF position. Remove the sediment cup, O-ring, and filter.
2. Clean the sediment cup, O-ring, and filter in nonflammable or high flash point solvent.
3. Reinstall the filter, O-ring, and sediment cup.

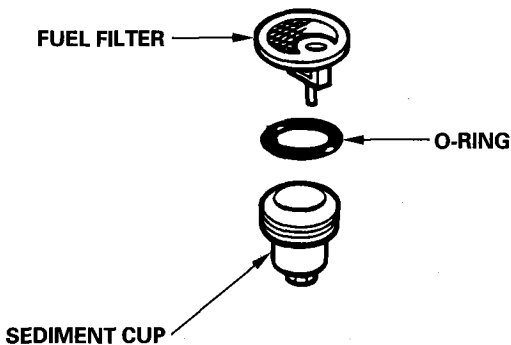
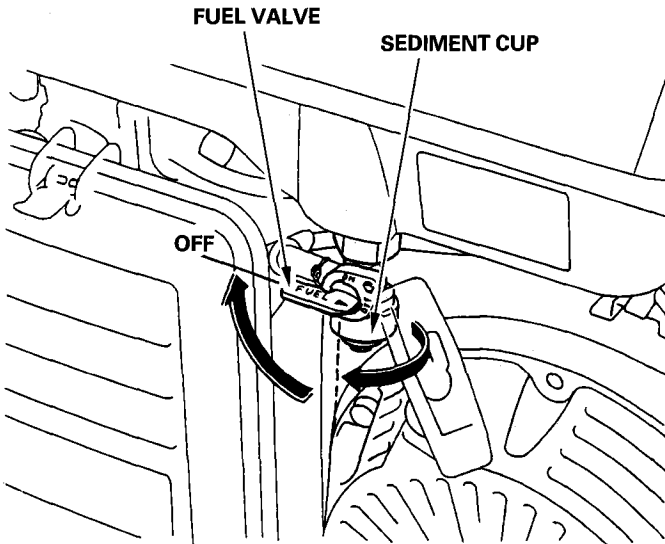



---

## SPARK PLUG SERVICE

In order to service the spark plug, you will need a spark plug wrench (commercially available).

**Recommended spark plugs:** BPR5ES (NGK)  
W16EPR-U (DENSO)

To ensure proper engine operation, the spark plug must be properly gapped and free of deposits.

If the engine has been running, the muffler will be very hot. Be careful not to touch the muffler.

1. Remove the spark plug cap.
2. Clean any dirt from around the spark plug base.
3. Use a spark plug wrench to remove the spark plug.

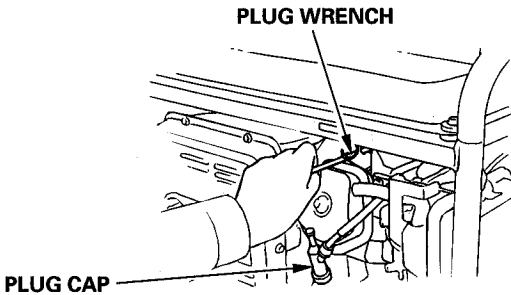

4. Visually inspect the spark plug. Discard it if the insulator is cracked or chipped. Clean the spark plug with a wire brush if it is to be reused.
5. Measure the plug gap with a feeler gauge. Correct as necessary by carefully bending the side electrode.

### The gap should be:

0.70–0.80 mm (0.028–0.031 in)



0.70–0.80 mm (0.028–0.031 in)

6. Check that the spark plug washer is in good condition, and thread the spark plug in by hand to prevent cross-threading.
7. After the spark plug is seated, tighten with a spark plug wrench to compress the washer.

—If installing a new spark plug, tighten 1/2 turn after the spark plug seats to compress the washer. If reinstalling a used spark plug, tighten 1/8 — 1/4 turn after the spark plug seats to compress the washer.

**NOTICE**

**The spark plug must be securely tightened. An improperly tightened spark plug can become very hot and could damage the engine. Never use spark plugs which have an improper heat range. Use only the recommended spark plugs or equivalent.**

### **Spark Arrester Maintenance**

If the generator has been running, the muffler will be very hot. Allow it to cool before proceeding.

**NOTICE**

**The spark arrester must be serviced every 100 hours to maintain its efficiency.**

Clean the spark arrester as follows:

1. Loosen the screw by the exhaust port of the muffler and remove the spark arrester.
2. Use a brush to remove carbon deposits from the spark arrester screen.  
Inspect the screen for breaks or tears and replace it if necessary.
3. Install the spark arrester in the reverse order of removal.

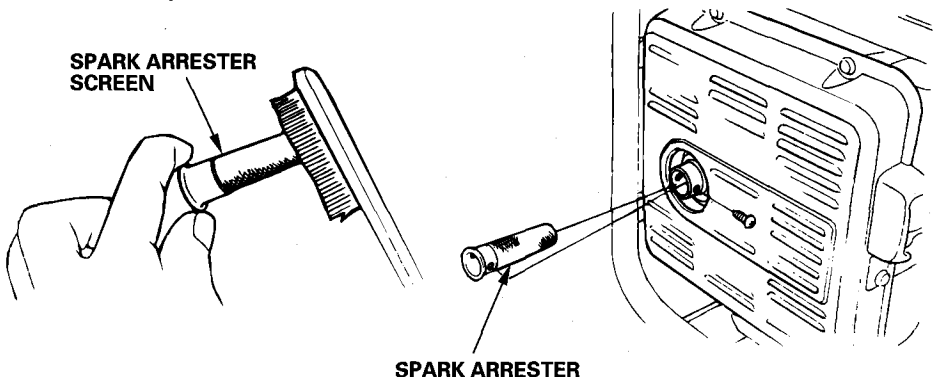

# TRANSPORTING/STORAGE

When transporting the generator, turn the engine switch OFF and keep the generator level to prevent fuel spillage. Fuel vapor or spilled fuel may ignite.

## ▲WARNING

**Contact with a hot engine or exhaust system can cause serious burns or fires. Let the engine cool before transporting or storing the generator.**

Take care not to drop or strike the generator when transporting. Do not place heavy objects on the generator.

Before storing the unit for an extended period:

1. Be sure the storage area is free of excessive humidity and dust.
2. Service according to the table below:

STORAGE TIME	RECOMMENDED SERVICE PROCEDURE TO PREVENT HARD STARTING
Less than 1 month	No preparation required
1 to 2 months	Fill with fresh gasoline and add gasoline conditioner*.
2 months to 1 year	Fill with fresh gasoline and add gasoline conditioner*. Drain the carburetor float bowl. Drain the fuel sediment cup.
1 year or more	Fill with fresh gasoline and add gasoline conditioner*. Drain the carburetor float bowl. Drain the fuel sediment cup. Remove the spark plug. Put a tablespoon of engine oil into the cylinder. Turn the engine slowly with the pull rope to distribute the oil. Reinstall the spark plug. Change the engine oil. After removal from storage, drain the stored gasoline into a suitable container, and fill with fresh gasoline before starting.
* Use gasoline conditioners that are formulated to extend storage life. Contact your authorized Honda generator dealer for conditioner recommendations.	

1. Drain the carburetor by loosening the drain screw. Drain the gasoline into a suitable container.

**▲WARNING**

**Gasoline is extremely flammable and is explosive under certain conditions. Perform this task in a well-ventilated area with the engine stopped. Do not smoke or allow flames or sparks in the area during this procedure.**

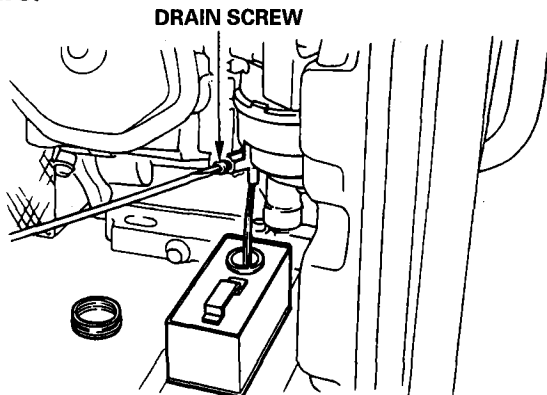

2. Change the engine oil (See page 36 ).

3. Remove the spark plug, and pour about a tablespoon of clean engine oil into the cylinder. Crank the engine several revolutions to distribute the oil, then reinstall the spark plug.

4. Slowly pull the starter grip until resistance is felt. At this point, the piston is coming up on its compression stroke and both the intake and exhaust valves are closed. Storing the engine in this position will help to protect it from internal corrosion.

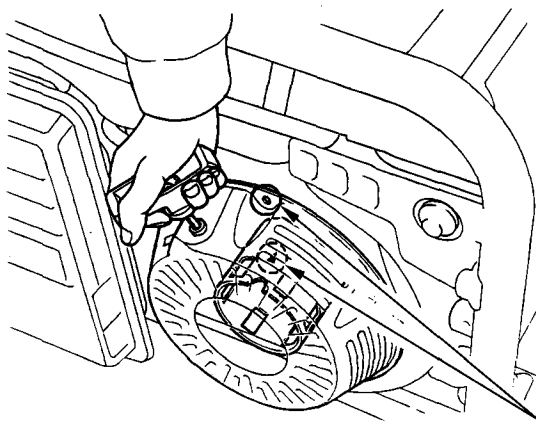

**Align the notch on the starter pulley with the hole at the top of recoil starter.**

When the engine will not start:

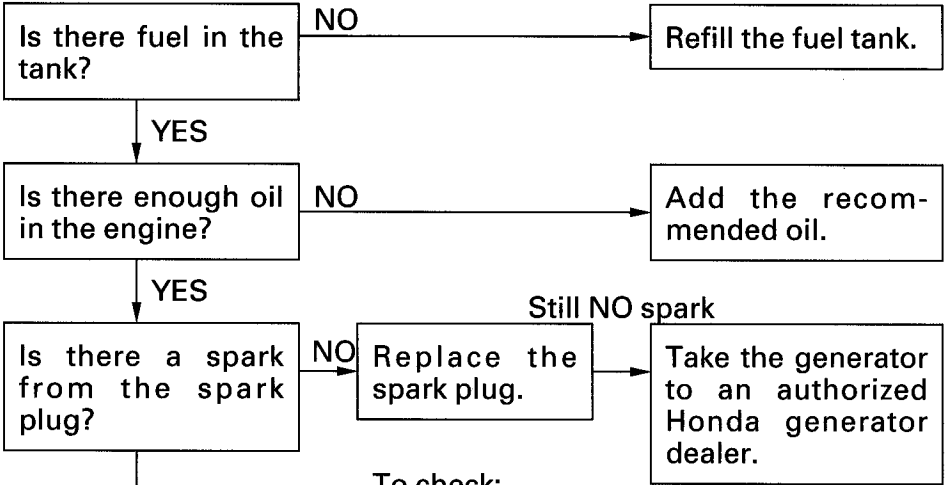

**▲WARNING**

**Be sure there is no spilled fuel around the spark plug. Spilled fuel may ignite.**

To check:

- 1) Remove the spark plug cap and clean any dirt from around the spark plug.
- 2) Remove the spark plug and install the spark plug in the plug cap.
- 3) Set the plug side electrode on the cylinder head.
- 4) Crank the engine, sparks should jump across the gap.

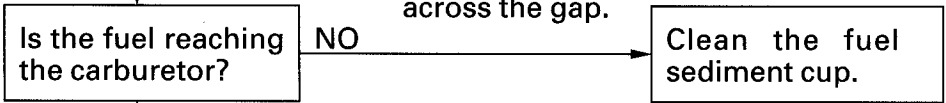
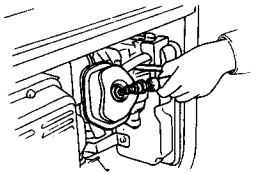

To check:

- 1) Turn off the fuel valve and loosen the drain screw.
- 2) Turn the fuel valve to ON. Fuel should flow from the drain when the fuel valve is turned ON.

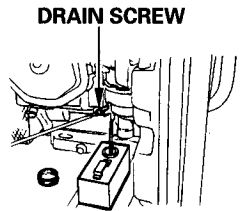

No electricity at the AC receptacles:

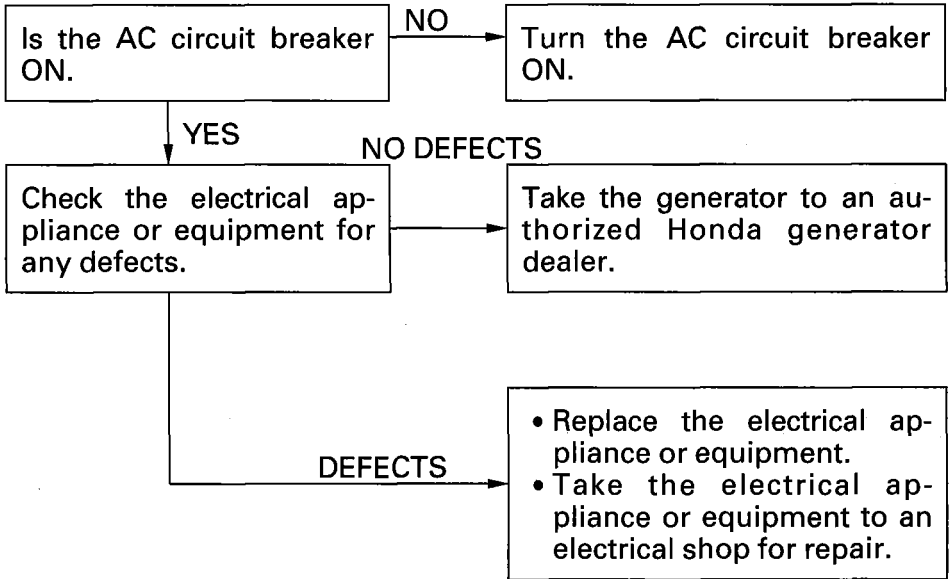

# WIRING DIAGRAM

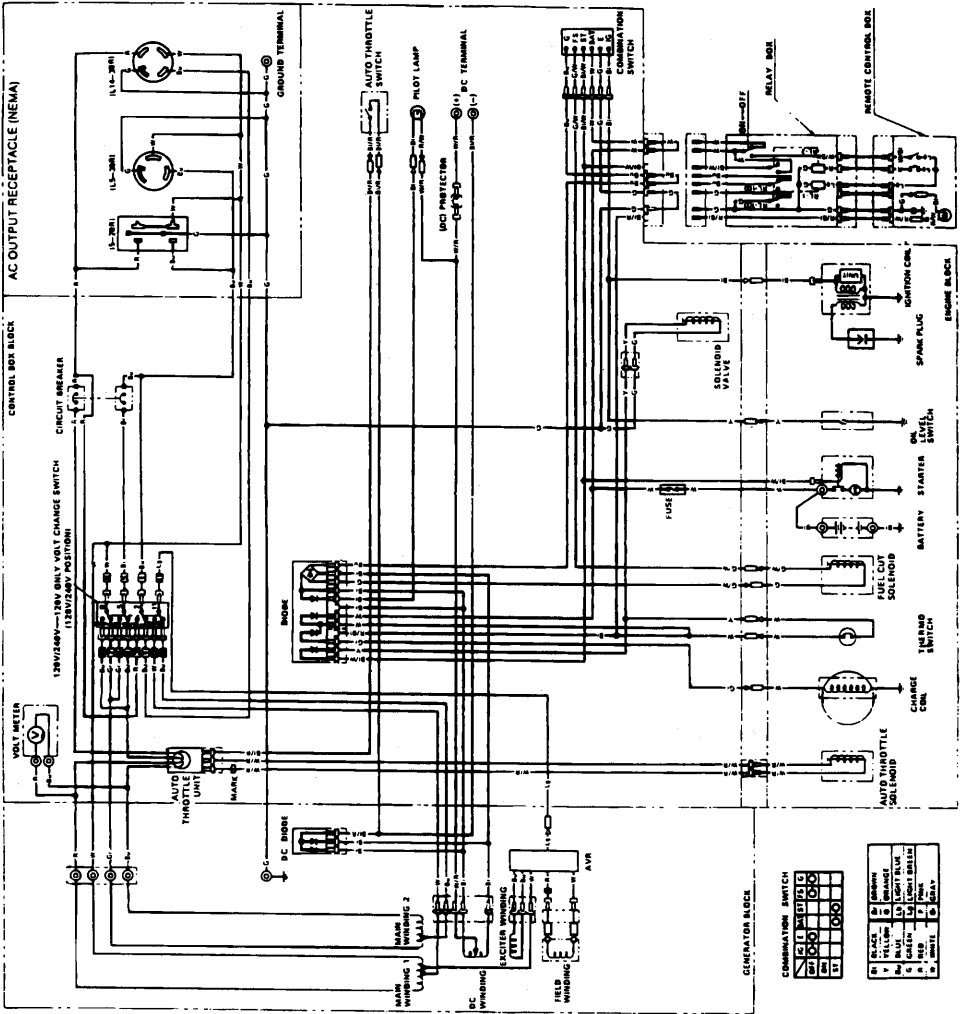

COMBINATION SWITCH

1	2	3	4	5	6	7	8	9	10
11	12	13	14	15	16	17	18	19	20

1	2	3	4	5	6	7	8	9	10
11	12	13	14	15	16	17	18	19	20

1	2	3	4	5	6	7	8	9	10
11	12	13	14	15	16	17	18	19	20

1	2	3	4	5	6	7	8	9	10
11	12	13	14	15	16	17	18	19	20

1	2	3	4	5	6	7	8	9	10
11	12	13	14	15	16	17	18	19	20

1	2	3	4	5	6	7	8	9	10
11	12	13	14	15	16	17	18	19	20

1	2	3	4	5	6	7	8	9	10
11	12	13	14	15	16	17	18	19	20

1	2	3	4	5	6	7	8	9	10
11	12	13	14	15	16	17	18	19	20

1	2	3	4	5	6	7	8	9	10
11	12	13	14	15	16	17	18	19	20

1	2	3	4	5	6	7	8	9	10
11	12	13	14	15	16	17	18	19	20

1	2	3	4	5	6	7	8	9	10
11	12	13	14	15	16	17	18	19	20

1	2	3	4	5	6	7	8	9	10
11	12	13	14	15	16	17	18	19	20

1	2	3	4	5	6	7	8	9	10
11	12	13	14	15	16	17	18	19	20

1	2	3	4	5	6	7	8	9	10
11	12	13	14	15	16	17	18	19	20

1	2	3	4	5	6	7	8	9	10
11	12	13	14	15	16	17	18	19	20

1	2	3	4	5	6	7	8	9	10
11	12	13	14	15	16	17	18	19	20

1	2	3	4	5	6	7	8	9	10
11	12	13	14	15	16	17	18	19	20

1	2	3	4	5	6	7	8	9	10
11	12	13	14	15	16	17	18	19	20

1	2	3	4	5	6	7	8	9	10
11	12	13	14	15	16	17	18	19	20

1	2	3	4	5	6	7	8	9	10
11	12	13	14	15	16	17	18	19	20

1	2	3	4	5	6	7	8	9	10
11	12	13	14	15	16	17	18	19	20

1	2	3	4	5	6	7	8	9	10
11	12	13	14	15	16	17	18	19	20

1	2	3	4	5	6	7	8	9	10
11	12	13	14	15	16	17	18	19	20

1	2	3	4	5	6	7	8	9	10
11	12	13	14	15	16	17	18	19	20

1	2	3	4	5	6	7	8	9	10
11	12	13	14	15	16	17	18	19	20

1	2	3	4	5	6	7	8	9	10
11	12	13	14	15	16	17	18	19	20

1	2	3	4	5	6	7	8	9	10
11	12	13	14	15	16	17	18	19	20

1	2	3	4	5	6	7	8	9	10
11	12	13	14	15	16	17	18	19	20

1	2	3	4	5	6	7	8	9	10
11	12	13	14	15	16	17	18	19	20

1	2	3	4	5	6	7	8	9	10
11	12	13	14	15	16	17	18	19	20

1	2	3	4	5	6	7	8	9	10
11	12	13	14	15	16	17	18	19	20

1	2	3	4	5	6	7	8	9	10
11	12	13	14	15	16	17	18	19	20

1	2	3	4	5	6	7	8	9	10
11	12	13	14	15	16	17	18	19	20

1	2	3	4	5	6	7	8	9	10
11	12	13	14	15	16	17	18	19	20

1	2	3	4	5	6	7	8	9	10
11	12	13	14	15	16	17	18	19	20

1	2	3	4	5	6	7	8	9	10
11	12	13	14	15	16	17	18	19	20

1	2	3	4	5	6	7	8	9	10
11	12	13	14	15	16	17	18	19	20

1	2	3	4	5	6	7	8	9	10
11	12	13	14	15	16	17	18	19	20

1	2	3	4	5	6	7	8	9	10
11	12	13	14	15	16	17	18	19	20

1	2	3	4	5	6	7	8	9	10
11	12	13	14	15	16	17	18	19	20

1	2	3	4	5	6	7	8	9	10
11	12	13	14	15	16	17	18	19	20

1	2	3	4	5	6	7	8	9	10
11	12	13	14	15	16	17	18	19	20

1	2	3	4	5	6	7	8	9	10
11	12	13	14	15	16	17	18	19	20

1	2	3	4	5	6	7	8	9	10
11	12	13	14	15	16	17	18	19	20

1	2	3	4	5	6	7	8	9	10
11	12	13	14	15	16	17	18	19	20

1	2	3	4	5	6	7	8	9	10
11	12	13	14	15	16	17	18	19	20

1	2	3	4	5	6	7	8	9	10
11	12	13	14	15	16	17	18	19	20

1	2	3	4	5	6	7	8	9	10
11	12	13	14	15	16	17	18	19	20

1	2	3	4	5	6	7	8	9	10
11	12	13	14	15	16	17	18	19	20

1	2	3	4	5	6	7	8	9	10
11	12	13	14	15	16	17	18	19	20

1	2	3	4	5	6	7	8	9	10
11	12	13	14	15	16	17	18	19	20

1	2	3	4	5	6	7	8	9	10
11	12	13	14	15	16	17	18	19	20

1	2	3	4	5	6	7	8	9	10
11	12	13	14	15	16	17	18	19	20

1	2	3	4	5	6	7	8	9	10
11	12	13	14	15	16	17	18	19	20

1	2	3	4	5	6	7	8	9	10
11	12	13	14	15	16	17	18	19	20

1	2	3	4	5	6	7	8	9	10
11	12	13	14	15	16	17	18	19	20

1	2	3	4	5	6	7	8	9	10
11	12	13	14	15	16	17	18	19	20

1	2	3	4	5	6	7	8	9	10
11	12	13	14	15	16	17	18	19	20

1	2	3	4	5	6	7	8	9	10
11	12	13	14	15	16	17	18	19	20

1	2	3	4	5	6	7	8	9	10
11	12	13	14	15	16	17	18	19	20

1	2	3	4	5	6	7	8	9	10
11	12	13	14	15	16	17	18	19	20

1	2	3	4	5	6	7	8	9	10
11	12	13	14	15	16	17	18	19	20

1	2	3	4	5	6	7	8	9	10
11	12	13	14	15	16	17	18	19	20

1	2	3	4	5	6	7	8	9	10
11	12	13	14	15	16	17	18	19	20

1	2	3	4	5	6	7	8	9	10
11	12	13	14	15	16	17	18	19	20

1	2	3	4	5	6	7	8	9	10
11	12	13	14	15	16	17	18	19	20

1	2	3	4	5	6	7	8	9	10
11	12	13	14	15	16				

# SPECIFICATIONS

## Dimensions

Model	EM5000SX
Power product description code	EA7
Length	655 mm (25.8 in)
Width	510 mm (20.1 in)
Height	490 mm (19.3 in)
Dry weight	80.0 kg (176.4 lbs)

## Engine

Model	GX340K1
Engine type	4-stroke, overhead valve, single cylinder
Displacement (Bore x Stroke)	337 cm <sup>3</sup> (20.6 cu-in) [82 × 64 mm (3.2 × 2.5 in)]
Compression ratio	8.0 : 1
Engine speed	3,600 rpm
Cooling system	Forced air
Ignition system	Transistorized magneto
Oil capacity	1.1 ℓ (1.2 US qt, 1.0 Imp qt)
Fuel tank capacity	17.0 ℓ (4.49 US gal, 3.74 Imp gal)
Spark plug	BPR5ES (NGK) W16EPR-U (DENSO)

## Generator

Model	EM5000SX	
Type	A	
AC output	Rated voltage	120/240 V
	Rated frequency	60 Hz
	Rated ampere	37.5/18.8 A
	Rated output	4.5 kVA
	Maximum output	5.0 kVA
DC output	Only for charging 12V automotive batteries. Maximum charging output = 8.3A	

## Tune-up Specifications

ITEM	SPECIFICATION	MAINTENANCE
Spark plug gap	0.70–0.80 mm (0.028–0.031 in)	Refer to page: 39
Valve clearance	IN: 0.15 ± 0.02 mm (cold) EX: 0.20 ± 0.02 mm (cold)	See your authorized Honda dealer
Other specifications	No other adjustments needed.	

### NOTE:

Specifications may vary according to the types, and are subject to change without notice.



# INSTALLATION OF OPTIONAL PARTS

## Remote Control Kit

1. Install the relay box on the right side of the generator.
2. Remove the blind 8-P connector from the back of the control box and connect the relay box connector instead.
3. Connect the remote control cable to the remote control and relay box.

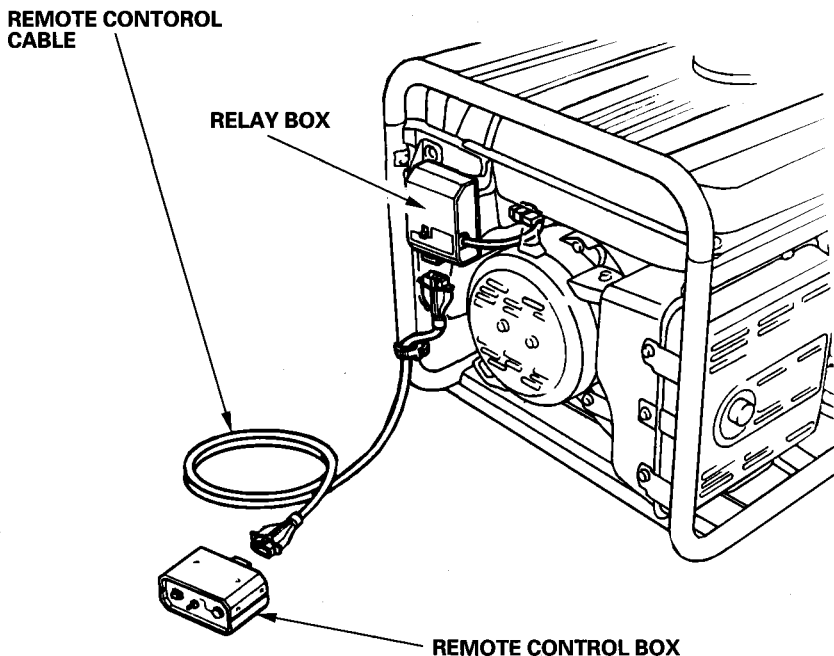

### NOTE:

- Connect the blind connector when not using the remote control.
- Engine will not start unless the blind connector is connected.

## Remote Control Box

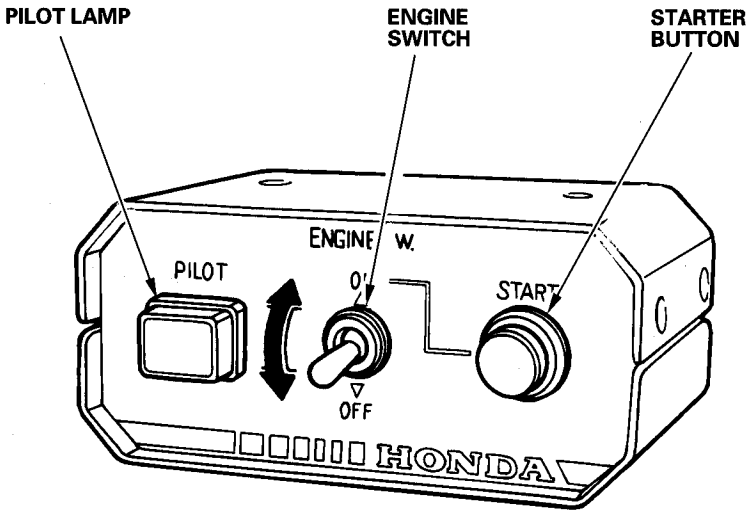

Starting the engine with remote control

1. Turn the fuel valve to the ON position.
2. Turn the auto-throttle switch to the OFF position.
3. Turn off the engine switch at the generator and remove the key.
4. Turn the relay box switch to the ON position.

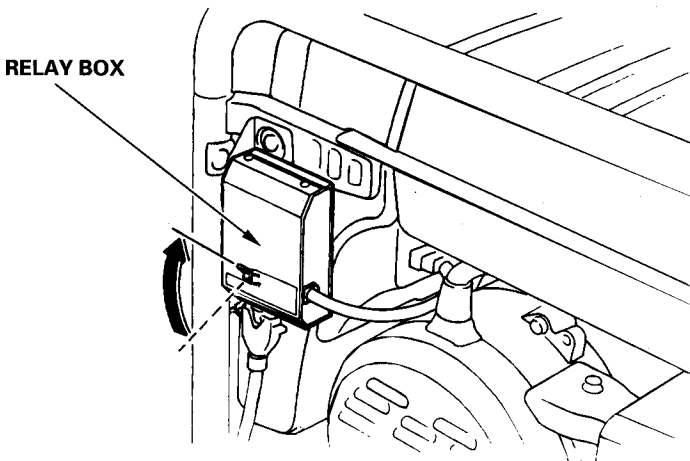

- 
5. Turn the engine switch at the remote control box to the ON position.
  6. Press the starter button until the pilot lamp comes on.

#### Stopping the engine

1. Turn the engine switch at the remote control box to the OFF position.
2. Turn the relay box switch to the OFF position.
3. Turn the fuel valve to the OFF position.

## 4 Wheel Kit Installation

1. Install the four wheels on the axle shaft.
2. Install the axle assembly on the generator using four bolts and nuts.

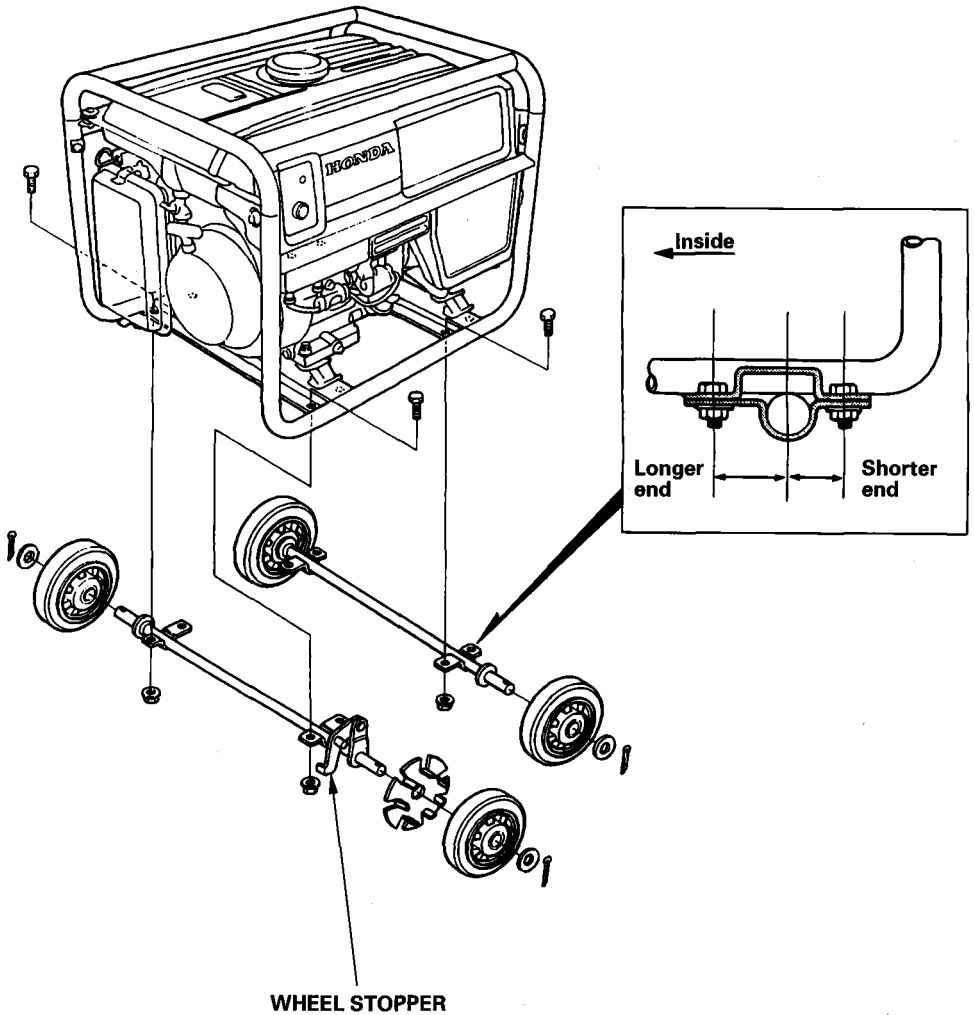

**NOTE:**  
Install the shaft with wheel stopper facing engine side.

---

## Battery Tray Kit

1. Install the battery guard on the frame.  
Set the battery tray on the battery guard and tighten the bolts.
2. Route the starter cable under the tank and connect it to the starter solenoid.
3. Connect the ground cable to the generator rear housing.
4. Set the battery on the battery tray and secure with the battery bracket.  
Connect the starter cable to the battery positive (+) terminal first, then to the negative (-) terminal. when disconnecting, disconnect at the battery negative (-) terminal first.
5. Install the battery guard plate on the battery guard.

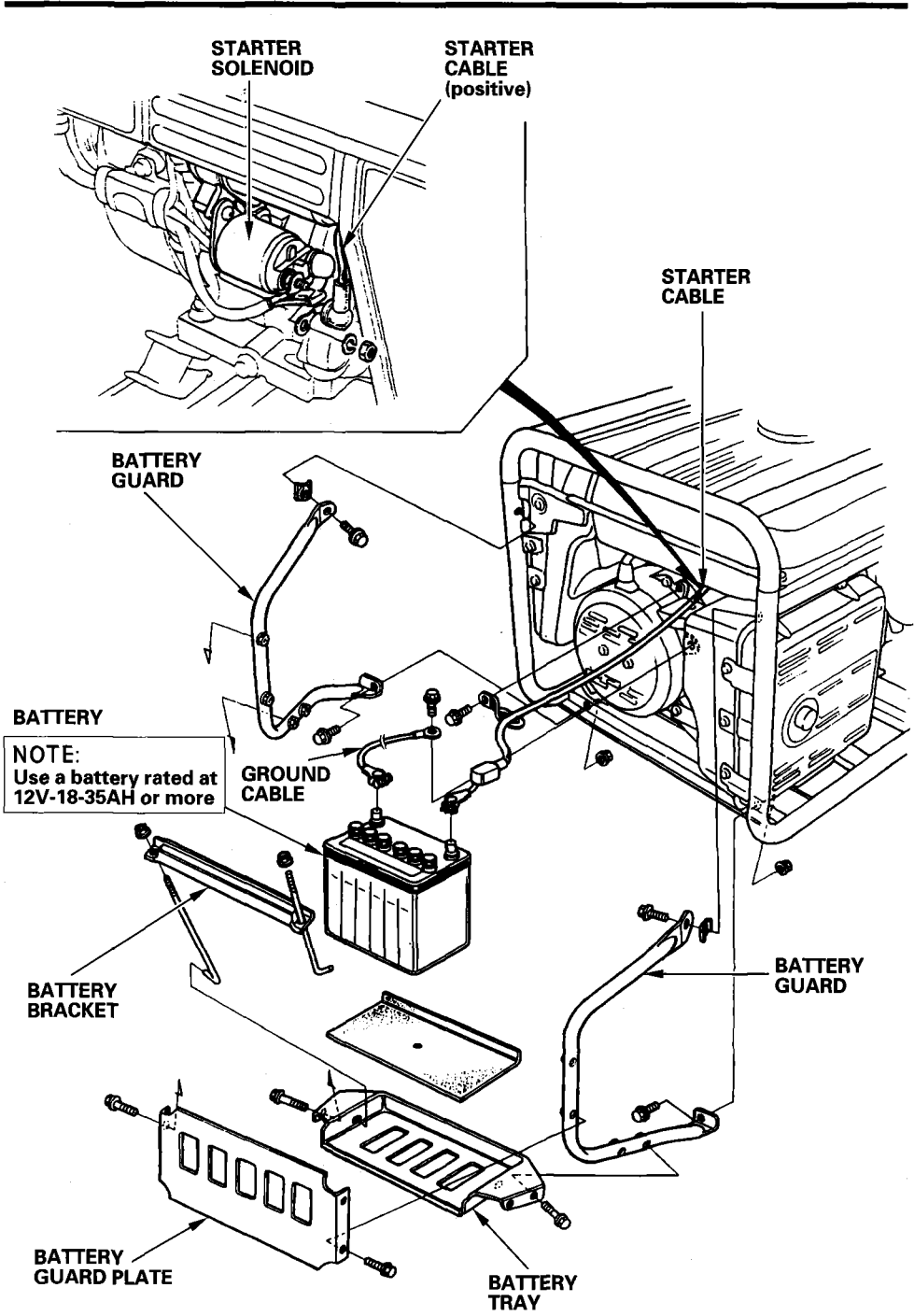

# **WARRANTY SERVICE INFORMATION**

---

Honda power equipment dealership personnel are trained professionals. They should be able to answer any question you may have. If you encounter a problem that your dealer does not solve to your satisfaction, please discuss it with the dealership's management. The Service Manager or General Manager can help. Almost all problems are solved in this way.

If you are dissatisfied with the decision made by the dealership's management, contact the Honda Power Equipment Customer Relations Office. You can write to:

American Honda Motor Co., Inc.  
Power Equipment Division  
Customer Relations Office  
4475 River Green Parkway  
Duluth, Georgia 30136-2565

Or telephone: (770) 497-6400

When you write or call, please give us this information:

- Model and serial number (see pages 8 and 9)
- Name of dealer who sold the generator to you
- Name and address of dealer who services your generator
- Date of purchase
- Your name, address, and telephone number
- A detailed description of the problem

## **Current customer service contact information:**

### **United States, Puerto Rico, and U.S. Virgin Islands:**

Honda Power Equipment dealership personnel are trained professionals. They should be able to answer any question you may have. If you encounter a problem that your dealer does not solve to your satisfaction, please discuss it with the dealership's management. The Service Manager or General Manager can help. Almost all problems are solved in this way.

If you are dissatisfied with the decision made by the dealership's management, contact the Honda Power Equipment Customer Relations Office. You can write:

American Honda Motor Co., Inc.  
Power Equipment Division  
Customer Relations Office  
4900 Marconi Drive  
Alpharetta, GA 30005-8847

Or telephone: (770) 497-6400 M-F, 8:30 am - 7:00 pm EST

When you write or call, please provide the following information:

- Model and serial numbers
- Name of the dealer who sold the Honda power equipment to you
- Name and address of the dealer who services your equipment
- Date of purchase
- Your name, address, and telephone number
- A detailed description of the problem



# INDEX

---

COMPONENT IDENTIFICATION .....	8
CONTROLS .....	10
Auto-throttle System .....	13
Choke Rod .....	11
Circuit Breaker .....	12
DC Circuit Protector .....	15
DC Terminals .....	15
Engine Switch .....	10
Fuel Valve .....	11
Ground Terminal .....	12
Oil Alert System .....	12
Pilot Lamp .....	14
Recoil Starter .....	10
Volt Meter .....	14
Voltage Selector Switch (Dual Voltage System) .....	14
GENERATOR USE .....	16
AC Applications .....	17
AC Operation .....	18
AC Receptacle Selection .....	19
Auto-throttle System .....	22
Connections to a Building's Electrical System .....	16
DC Operation .....	20
Disconnecting the battery cables .....	21
Generator Ground Circuits .....	16
High Altitude Operation .....	23
INSTALLATION OF OPTIONAL PARTS .....	47
MAINTENANCE .....	30
Air Cleaner Service .....	37
Emission Control System .....	32
Engine Oil Change .....	36
Fuel Sediment Cup Cleaning .....	38
Importance of Maintenance .....	30
Maintenance Safety .....	31
Maintenance Schedule .....	35
Spark Arrester Maintenance .....	40
Spark Plug Service .....	39
PRE-OPERATION CHECK .....	24
Engine Oil .....	24
Fuel Recommendation .....	25
SAFETY .....	4
Safety Information .....	6
Safety Label Locations .....	4

---

SPECIFICATIONS .....	46
STARTING THE ENGINE .....	28
STOPPING THE ENGINE .....	29
TRANSPORTING/STORAGE .....	41
TROUBLESHOOTING .....	43
WARRANTY SERVICE INFORMATION .....	53
WIRING DIAGRAM .....	45

---

**MEMO**

**HONDA**  
HONDA MOTOR CO., LTD. TOKYO, JAPAN

31ZC2672  
00X31-ZC2-6720

**EM** K1 AH 英 Y HC 10009807  
PRINTED IN JAPAN