

HONDA GENERATOR/WELDER

EXW171S

OWNER'S MANUAL

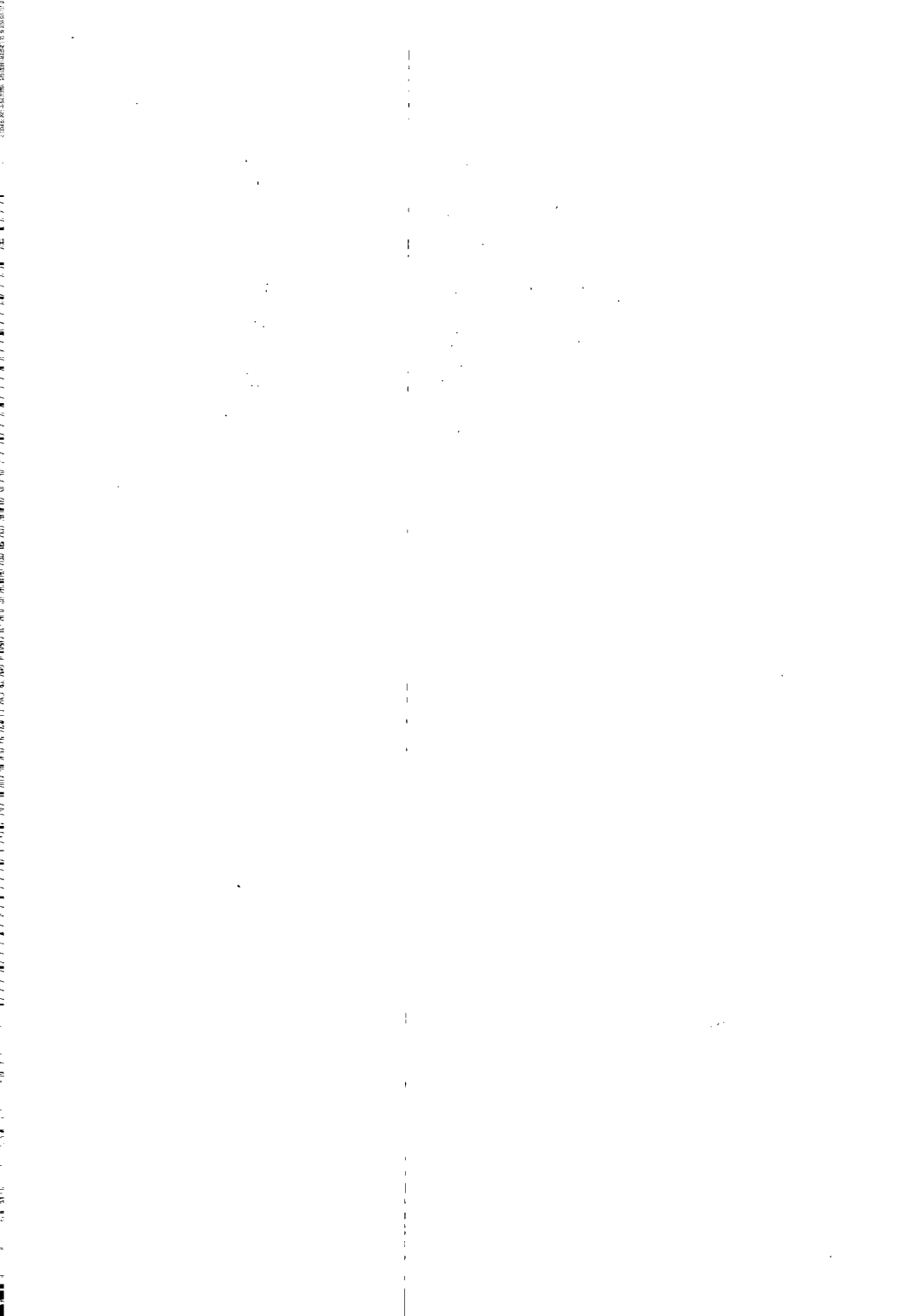



Thank you for purchasing a Honda generator/welder.

This manual covers the operation and maintenance of the EXW171S generator/welder. All information in this publication is based on the latest product information available at the time of printing.

Honda Motor Co., Ltd. reserves the right to make changes at any time without notice and without incurring any obligation.

No part of this publication may be reproduced without written permission.

This manual should be considered a permanent part of the generator/welder and should remain with the generator/welder if it is resold.

This generator/welder is equipped with a U.S.D.A. qualified spark arrester which requires periodic maintenance to ensure its effectiveness. It is illegal in some areas to operate an engine without a spark arrester; check local laws and regulations.



WARNING Indicates a strong possibility of severe personal injury or loss of life if instructions are not followed.

CAUTION: Indicates a possibility of personal injury or equipment damage if instructions are not followed.

NOTE: Gives helpful information.

If a problem should arise, or if you have any questions about your generator/welder, consult an authorized Honda dealer.



- **Welding is potentially a very hazardous activity. It should only be attempted by a trained welder with a thorough knowledge of proper welding techniques and safety procedures.**
- **Honda generator/welders are designed to give safe operation and dependable service if operated according to instructions. Read and understand this Owner's Manual before operating the generator/welder. Failure to do so could result in personal injury or equipment damage.**

CONTENTS

CONTENTS

1. GENERATOR/WELDER SAFETY	3
2. COMPONENT IDENTIFICATION	7
3. PRE-OPERATION CHECK	9
4. STARTING THE ENGINE	13
5. GENERATOR/WELDER OPERATION	16
6. STOPPING THE ENGINE	25
• High altitude operation	26
7. MAINTENANCE	27
8. TRANSPORTING/STORAGE	37
9. TROUBLESHOOTING	38
10. SPECIFICATIONS	40
11. WIRING DIAGRAM	41
12. WARRANTY SERVICE	42

1. GENERATOR/WELDER SAFETY



TO ENSURE SAFE OPERATION —

- Place the generator/welder on a firm, level surface; avoid loose sand or snow. If the generator/welder is tilted or overturned, fuel spillage and a fire may result.
- To prevent fire hazards and to provide adequate ventilation, keep the generator/welder at least 1 meter (3 feet) away from buildings and other equipment during operation. Do not place flammable objects close to the generator/welder.
- Children and pets must be kept away from the area of operation due to a possibility of electric shock or burns from hot components.
- Know how to stop the generator/welder quickly, and understand the operation of all the controls. Never permit anyone to operate the generator/welder without proper instruction.
- The generator/welder is a potential source of electrical shocks if misused. Do not operate the generator/welder in rain or snow. Do not let the generator/welder get wet, and do not operate it with wet hands.
- Use adequate eye protection. Eye protection is of the utmost importance, not only for the operator, but also for any other personnel in the vicinity while welding is being done. Eye hazards include arc glare, reflected glare, stray flashes, sparks, and flying bits of molten metal.
- Looking at a welding arc with unprotected eyes may produce severe pain and even temporary blindness.
- Use a helmet or hand-held shield with a #10 or darker filter lens. Filter lenses eliminate the harmful effects of infrared and ultraviolet radiation from the arc and reduce the glare from the arc light as well.
- Wear protective clothing such as leather gloves, cap, sleeves, jacket, apron, and high-top safety shoes. All outer clothing must be free of oil and grease.

FACE SHIELD

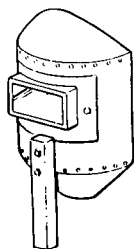

GLOVES



SAFETY SHOES



APRON

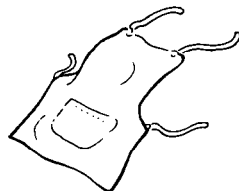

 **WARNING**

- Gasoline is extremely flammable and is explosive under certain conditions.
- Refuel in a well-ventilated area with the engine stopped. Do not smoke or allow flames or sparks in the refueling area or where gasoline is stored.
- Do not overfill the fuel tank. After refueling, make sure the tank cap is closed properly and securely.
- Be careful not to spill fuel when refueling. Fuel vapor or spilled fuel may ignite. If any fuel is spilled, make sure the area is dry before starting the engine.
- Never run the engine in an enclosed or confined area. Exhaust contains poisonous carbon monoxide gas; exposure may cause loss of consciousness and may lead to death.
- Provide adequate ventilation when welding; welding vapors are harmful to your health.
- The muffler becomes very hot during operation and remains sufficiently hot to inflict burns if touched, even after shutting off the engine. To prevent severe burns or fire hazards, let the engine cool before transporting the generator/welder or storing it indoors.
- Connections for standby power to a building's electrical system must be made by a qualified electrician and must comply with all applicable laws and electrical codes. Improper connections can allow electrical current from the generator to backfeed into the utility lines. Such backfeed may electrocute utility company workers or others who contact the lines during a power outage, and when utility power is restored, the generator may explode, burn, or cause fires in the building's electrical system.

CAUTION: Equipment damage and corrosion from sand, dirt, and water may occur if the generator is overturned or sinks into a soft surface.

Read these labels before you operate the generator/welder.

**HOT · EXHAUST
ECHAPPEMENT · CHAUD** ↓

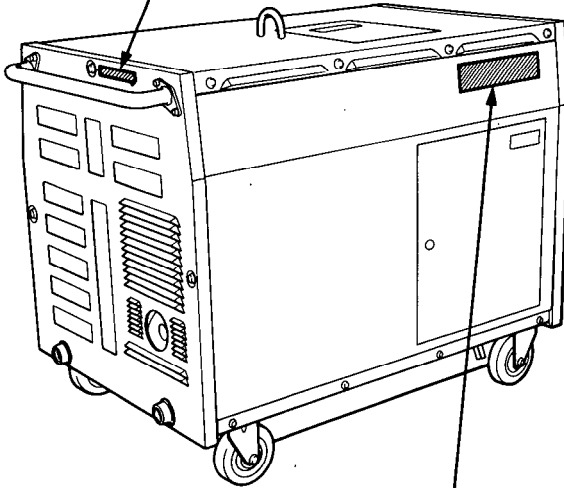

EXW 171S		HONDA MOTOR CO., LTD.	MADE IN JAPAN
CAUTION □ BE SURE TO FILL CRANKCASE WITH RECOMMENDED OIL BEFORE USING. FOR DETAILED EXPLANATION, SEE THE OWNER'S MANUAL.	WELDER OUTPUT CURRENT RANGE 50-170Amps DC RATED CURRENT 130A-28.5V-DC DUTY CYCLE 50%-130A	AC OUTPUT VOLTAGE 120V FREQUENCY 60Hz OUTPUT 4.0kVA FUEL GASOLINE (PETROL)	

WARNING	DO NOT USE INDOORS. EXHAUST GAS CONTAINS POISONOUS CARBON MONOXIDE.
ATTENTION	NE PAS UTILISER DANS UN ENDROIT FERME A CAUSE DU RISQUE D'EMPOISONNEMENT DU GAZ.
ATENCIÓN	NO LO USE EN LUGARES CERRADOS PORQUE EL MONOXIDE DE CARBONO ES VENENOSO.

⚠ WARNING
 ELECTROCUTION OR PROPERTY DAMAGE CAN OCCUR. DO NOT CONNECT THIS GENERATOR TO ANY BUILDING'S ELECTRICAL SYSTEM UNLESS AN ISOLATION SWITCH HAS BEEN INSTALLED BY A LICENSED ELECTRICIAN. READ OWNER'S MANUAL CAREFULLY.

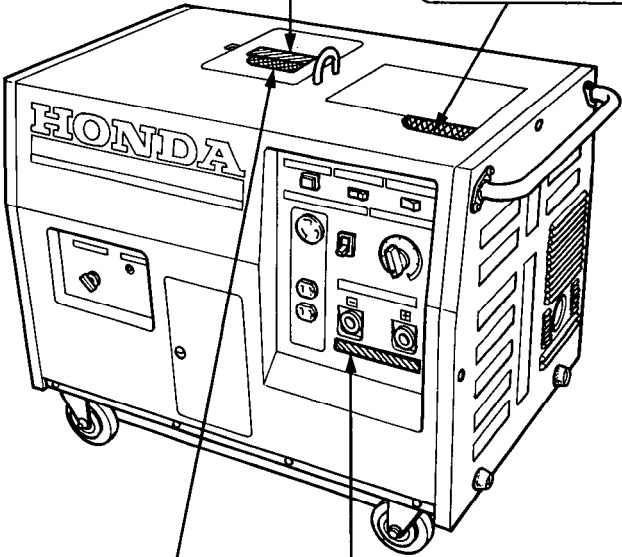

WARNING: TO PREVENT SEVERE ELECTRICAL SHOCK DO NOT INSERT FINGERS OR OBJECTS INTO THE WELDER TERMINALS.

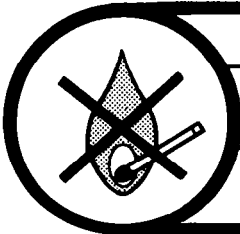

<p>■ CHECK FOR SPILLED FUEL OR FUEL LEAKS. STOP ENGINE BEFORE REFUELING.</p> <p>■ CONTRÔLER QU'IL N'Y A NI FUITE NI ESSENCE RÉPANDUE SUR L'APPAREIL. ARRÊTER LE MOTEUR AVANT DE REFAIRE LE PLEIN.</p> <p>■ INSPECCIONAR PARA COMBUSTIBLE DERRAMADO O ESCAPE. PARAR MOTOR ANTES DE ECHAR.</p>
--

2. COMPONENT IDENTIFICATION

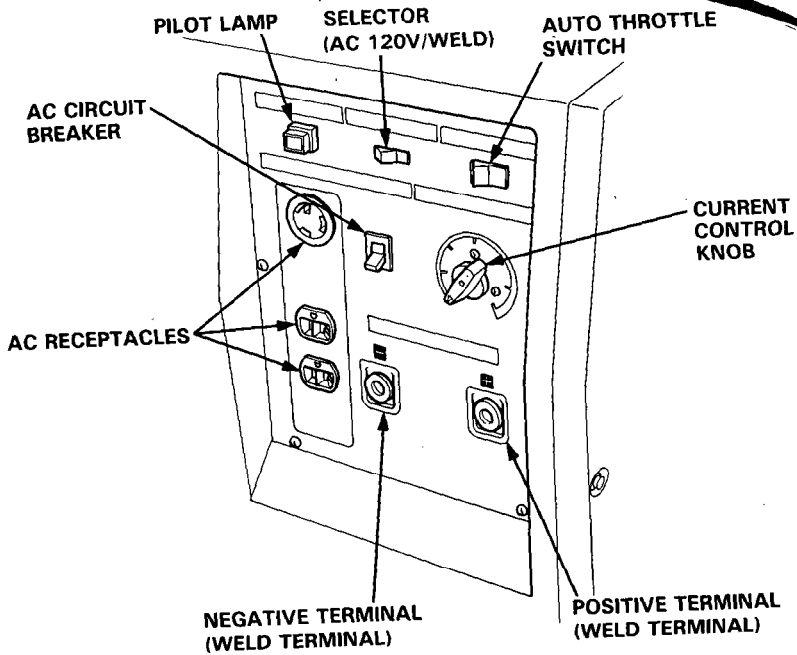
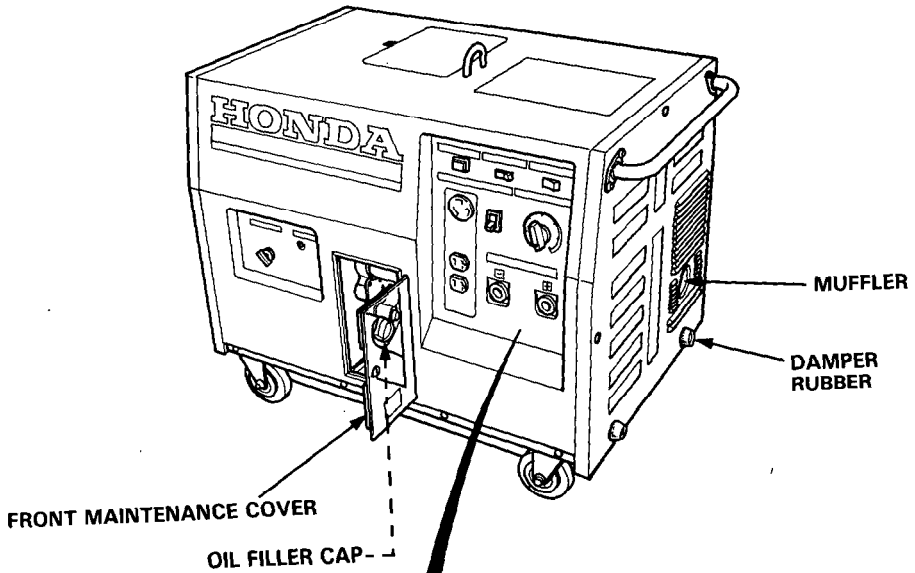

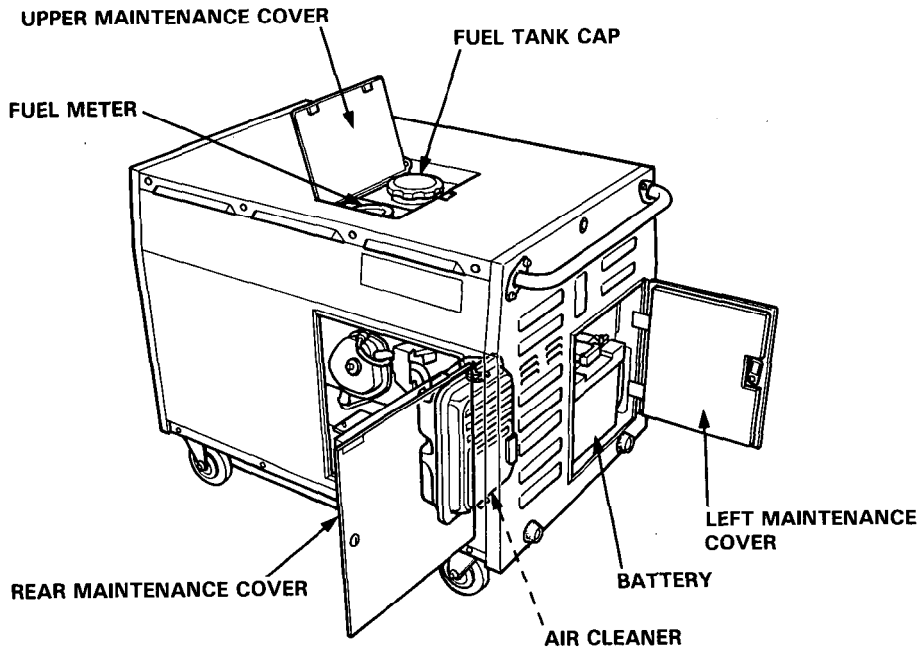
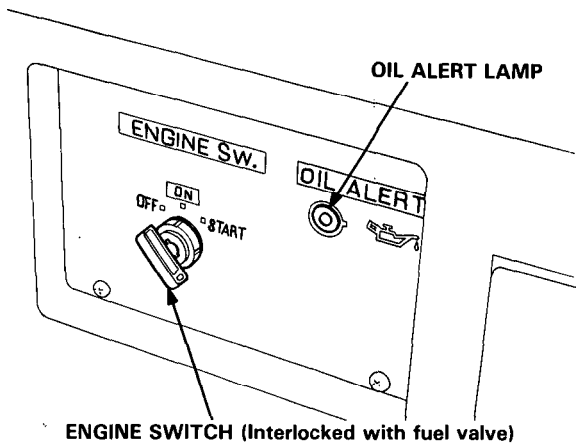

3. PRE-OPERATION CHECK

Check the generator/welder on a level surface with the engine stopped.

Engine Oil

CAUTION: Engine oil is a major factor affecting engine performance and service life. Nondetergent oils, castor-based oils, and 2-stroke oils are not recommended because they have inadequate lubricating characteristics.

Use Honda 4-stroke oil or an equivalent high-detergent, premium quality motor oil certified to meet or exceed U.S. automobile manufacturer's requirements for Service Classification SE or SF. Motor oils classified SE or SF will show this designation on the container.

SAE 10W-40 is recommended for general, all-temperature use. Other viscosities shown in the chart may be used when the average temperature in your area is within the indicated range.

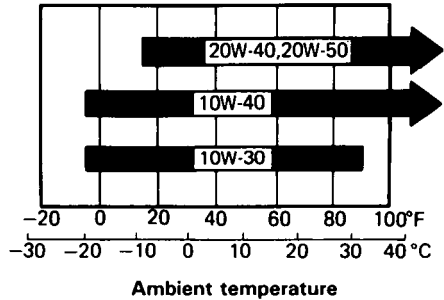

1. Remove the oil filler cap and wipe the dipstick clean.
2. Check the oil level by inserting the dipstick in the filler neck without screwing it in.
3. If the level is low, fill to the top of the oil filler neck with the recommended oil.

NOTE: The Oil Alert System will automatically stop the engine before the oil level falls below the safe limit. However, to avoid the inconvenience of an unexpected shutdown, it is advisable to visually inspect the oil level regularly.

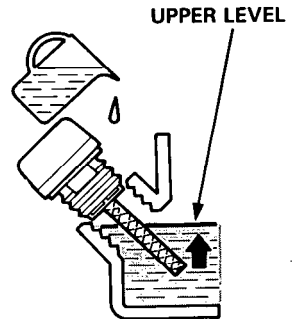
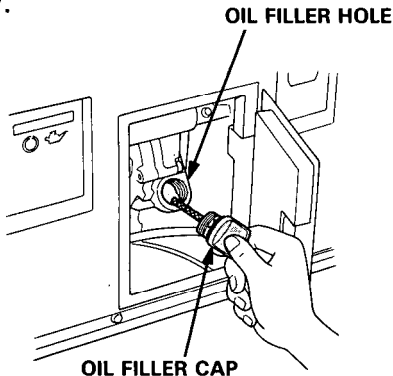

Fuel

Check the fuel gauge and refill the tank if the fuel level is low. Do not fill above the UPPER LEVEL line.

Use automotive gasoline with a pump octane number ($\frac{R + M}{2}$) of 86 or higher, or a research octane number of 91 or higher (unleaded is preferred to minimize combustion chamber deposits.)

Never use an oil/gasoline mixture or dirty gasoline. Avoid getting dirt, dust or water in the fuel tank. Clean the fuel strainer regularly.

WARNING

- Gasoline is extremely flammable and is explosive under certain conditions.
- Refuel in a well-ventilated area with the engine stopped. Do not smoke or allow flames or sparks in the refueling area or where gasoline is stored.
- Do not overfill the fuel tank. After refueling, make sure the tank cap is closed properly and securely.
- Be careful not to spill fuel when refueling. Fuel vapor or spilled fuel may ignite. If any fuel is spilled, make sure the area is dry before starting the engine.

Fuel tank capacity: 19.0 ℓ (5.0 US Gal., 4.2 Imp Gal.)

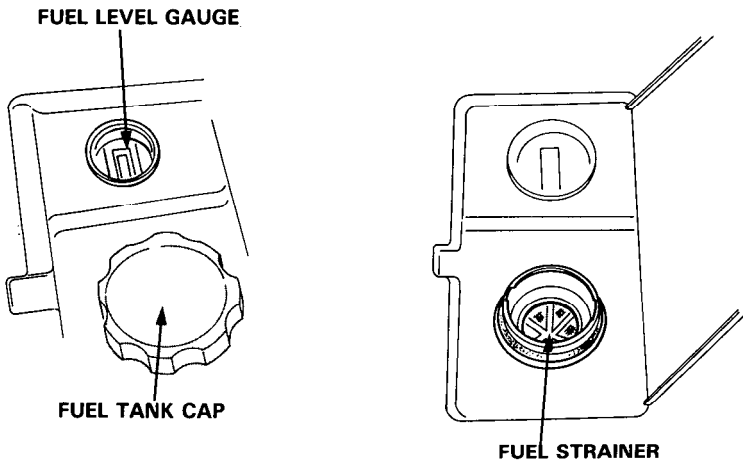

Gasolines Containing Alcohol

If you decide to use a gasoline containing alcohol ("gasohol"), be sure its octane rating is at least as high as that recommended by Honda. There are two types of "gasohol": that containing ethanol, and that containing methanol. Do not use gasohol that contains more than 10% ethanol. Do not use gasoline containing methanol (methyl or wood alcohol) that does not also contain cosolvents and corrosion inhibitors for methanol. Never use gasoline containing more than 5% methanol, even if it has cosolvents and corrosion inhibitors.

NOTE:

- Fuel system damage or engine performance problems resulting from the use of such fuels are not covered under Power Equipment Warranties. Honda cannot endorse the use of fuels containing methanol since evidence of their suitability is as yet incomplete.
- Before purchasing fuel from an unfamiliar station, try to confirm whether the fuel contains alcohol, and to what percentage. If you notice any undesirable operating symptoms after using a gasoline that contains alcohol, or one that you think contains alcohol, switch to a gasoline that you know does not contain alcohol.

Check the Battery

The electrolyte level must be maintained between the UPPER and LOWER level marks. If the electrolyte level is near the LOWER mark, add distilled water.

WARNING

- Protect your eyes, skin, and clothing; battery electrolyte contains sulphuric acid. Antidote: **EXTERNAL** — Flush with water. **INTERNAL** — Drink large quantities of water or milk. Follow with milk of magnesia, beaten egg, or vegetable oil. Call a physician immediately. Eyes: Flush with water and get prompt medical attention.
- Do not smoke or allow flames or sparks near a battery, especially during charging. Batteries produce explosive gases.

CAUTION:

- Use only distilled water in the battery. Tap water will shorten the service life of the battery.
- Do not fill the battery above the UPPER LEVEL line. If overfilled, electrolyte may overflow and corrode generator components. Immediately wash off any spilled electrolyte.

Check the battery terminals to be sure the cables are tightened and free of corrosion. Remove any corrosion, and coat the terminals and cable ends with grease.

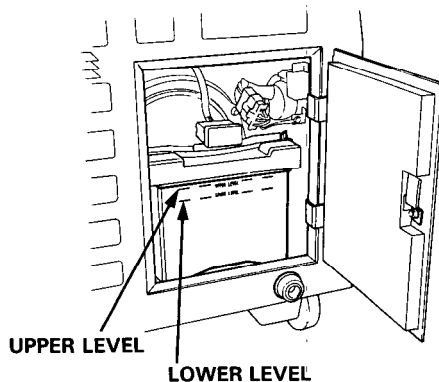

NOTE: Use a battery rated at 12V—18—35 AH or more.

Air Cleaner

Check the air cleaner element to be sure it is clean and in good condition. Clean or replace the element if necessary (page 30).

CAUTION: Never run the engine without the air cleaner. Rapid engine wear will result from contaminants, such as dust and dirt, being drawn through the carburetor, into the engine.

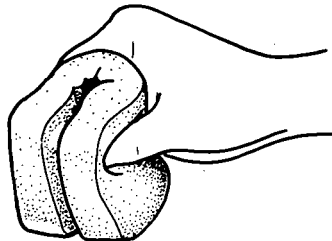
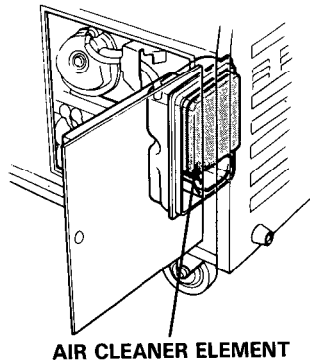
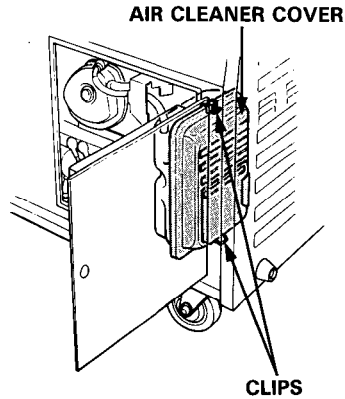

4. STARTING THE ENGINE

NOTE: When starting the generator after adding fuel for the first time, after long-term storage, or after running out of fuel, turn the engine switch to the "ON" position, then wait for 10 to 20 seconds before starting the engine.

1. Turn off the AC circuit breaker.

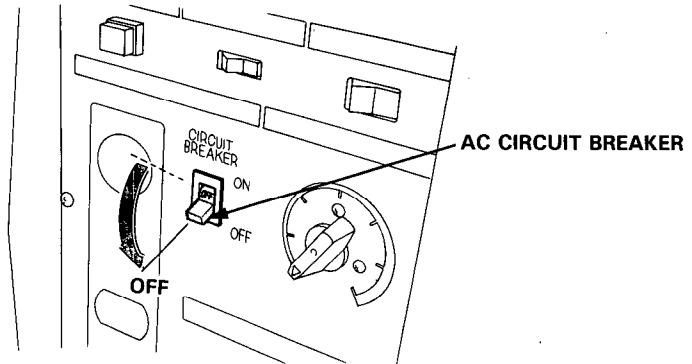

2. Make sure the auto-throttle switch is off, or more time will be required for warm up.

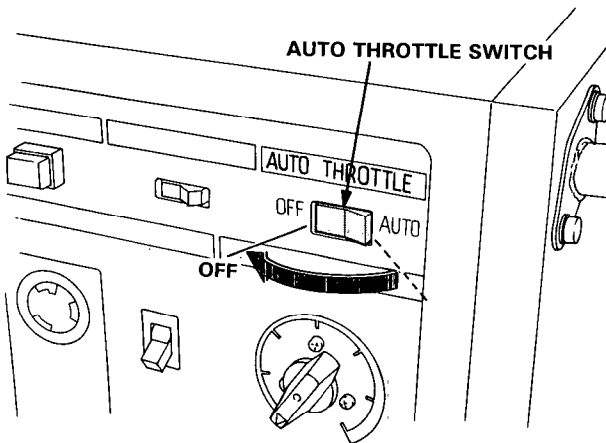

3. Turn the engine switch to the START position and hold it there until the engine starts.

NOTE: Do not use the electric starter for more than 5 seconds at a time. If the engine fails to start, release the switch and wait 10 seconds before operating the starter again.

When the engine starts, allow the engine switch to return to the ON position.

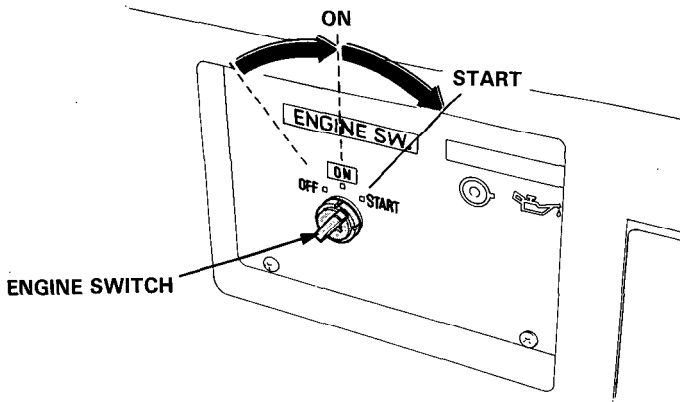

4. If auto-throttle will be used, turn the switch to "AUTO" after the engine has warmed up.

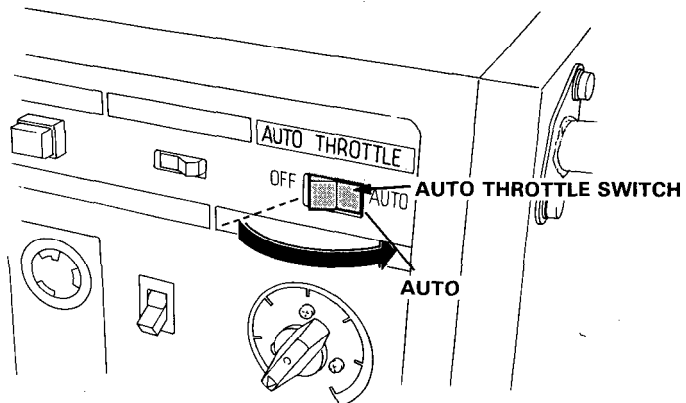

5. GENERATOR/WELDER OPERATION



Connections for standby power to a building's electrical system must be made by a qualified electrician and must comply with all applicable laws and electrical codes. Improper connections can allow electrical current from the generator to backfeed into the utility lines. Such backfeed may electrocute utility company workers or others who contact the lines during a power outage, and when utility power is restored, the generator may explode, burn, or cause fires in the building's electrical system.

Auto-throttle System

With the switch in the AUTO position, engine speed is automatically reduced to an idle when all loads are turned off or disconnected. When appliances are turned on or reconnected, the engine resumes the rated speed. At OFF, the auto-throttle system does not operate.

NOTE:

- AUTO is recommended to minimize fuel consumption when no load is applied.
- To avoid extended warm-up periods, keep the AUTO switch OFF until the engine reaches operating temperature.
- The auto-throttle system will not respond to electrical loads of less than 1 ampere.
- The system is not-effective for use with an appliances that require only momentary power.

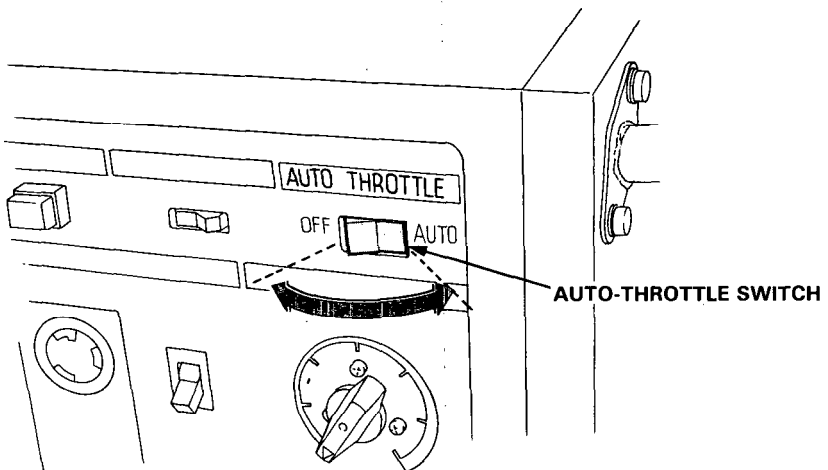

Oil Alert System

The Oil Alert system is designed to prevent engine damage caused by an insufficient amount of oil in the crankcase. Before the oil level in the crankcase can fall below a safe limit, the Oil Alert system will automatically shut down the engine (the engine switch will remain in the ON position).

If the Oil Alert system shuts down the engine, the Oil Alert lamp will flash when you operate the starter, and the engine will not run. If this occurs, add engine oil (page 9).

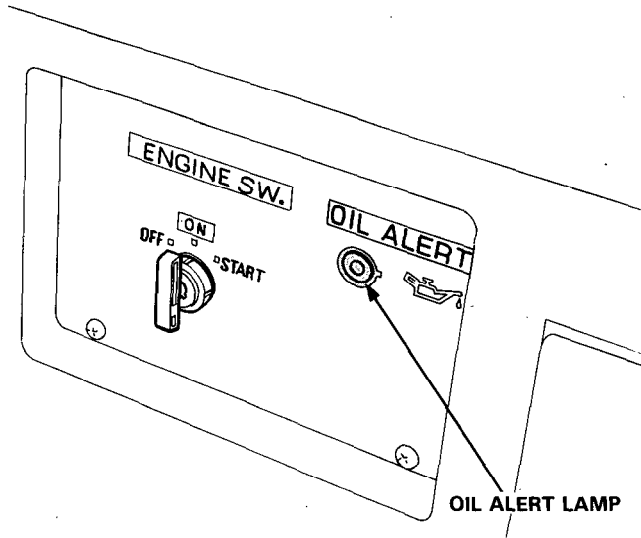

AC operation

1. Start the engine.
2. Turn the AC/DC (Weld) selector switch to AC position.

CAUTION: Under no circumstances should any type of electrical appliance be plugged into any of the AC receptacles when the selector is in the DC (WELD) position. AC voltage is present at the AC receptacles at all times regardless of the position of the AC/DC (WELD) selector. However, when this selector is in the DC (WELD) position, the AC voltage is unregulated and fluctuates considerably.

3. Switch on the AC circuit breaker.
4. Plug in the appliance.

CAUTION:

- Do not connect the generator/welder directly to a household circuit. This could cause damage to the generator or to electrical wiring and appliances in the house.
- For continuous operation, do not exceed the rated load capacity 4.0 KVA. In either case, be sure to consider the total power requirements of all connected appliances. Do not exceed the current limit specified for any one receptacle. Substantial overloading will switch off the circuit breaker. Marginal overloading may not switch off the circuit breaker, but it will shorten the service life of the generator/welder.
- If an overloaded circuit causes the AC circuit breaker to switch off, reduce the electrical load on the circuit, and wait a few minutes before resetting the circuit breaker.
- Be sure that all appliances are in good working order before connecting them to the generator. If an appliance begins to operate abnormally, becomes sluggish, or stops suddenly, turn off the circuit breaker and the engine switch immediately. Then disconnect the appliance and examine it for signs of malfunction.
- Most appliance and power tool motors require more than the rated operating current for start-up. To match appliance power needs to generator capability, allow a sufficient generator power reserve to accommodate motor start-up requirements.

NOTE: Appliance and power tool manufacturers usually list rating information near the model number or serial number.

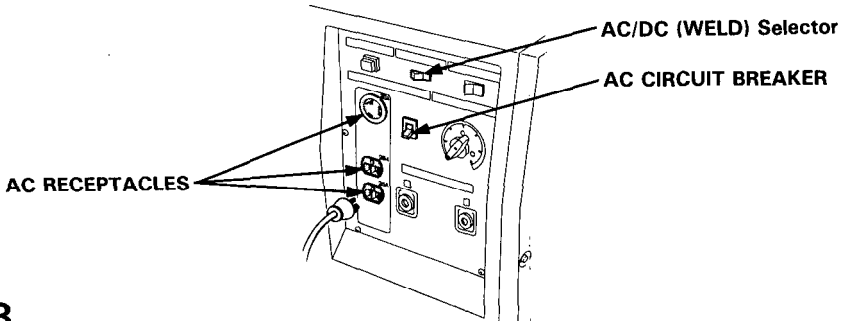

WELDING



WARNING Welding is potentially a very hazardous activity. It should only be attempted by a trained welder with a thorough knowledge of proper welding techniques and safety procedures. Be sure to read and follow the safety rules on pages 3, 4, 5 and 6 of this manual.

1. Put the Engine Switch in the OFF position. Turn the AC circuit breaker off and remove any plugs from the AC receptacles.

CAUTION: Voltage is present at the welding terminals whenever the engine is running regardless of the position of the AC/DC (WELD) selector.

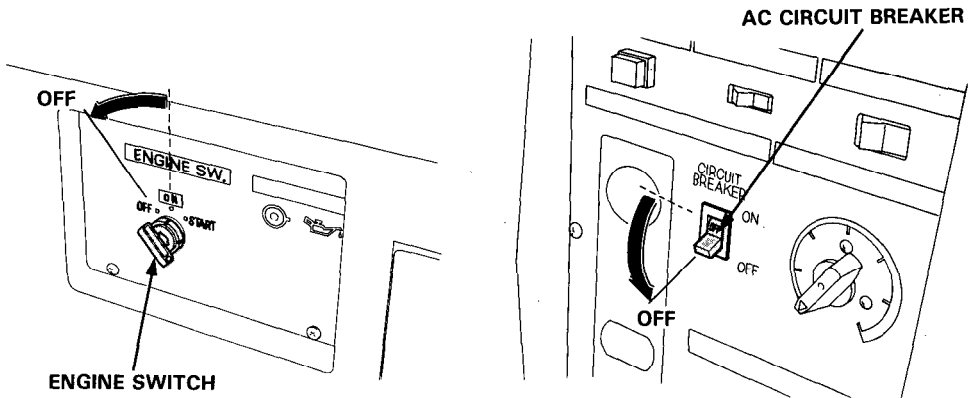

-
2. Connect the welding cables to the welder's DC terminals (See page 23 and 24).

CAUTION: Failure to use the proper gauge cable may lead to painful burns and/or damage to equipment. See table on page 23.

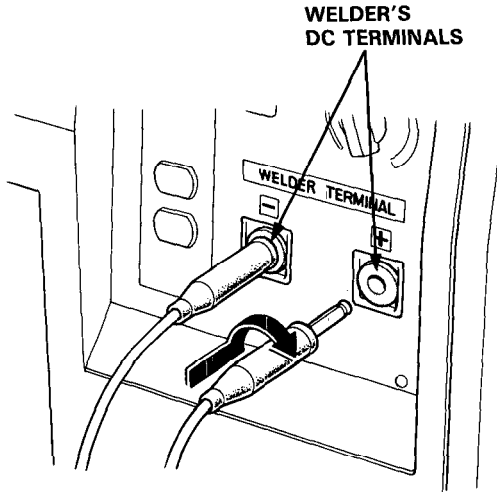

3. Start the engine and when it has warmed up fully, turn the Auto-Throttle Switch to the AUTO position.

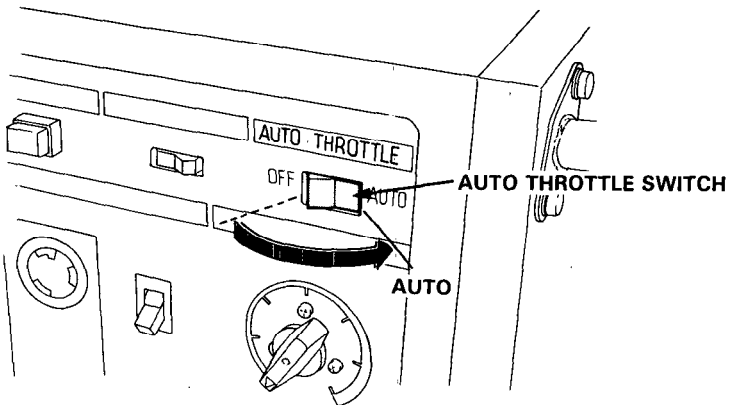

4. Turn the AC/DC (WELD) selector to the DC (WELD) position.

CAUTION:

- To avoid accidental arcing, one cable end should be firmly attached to the object to be welded, and the electrode holder at the end of the other cable should be held in the operator's hand when the DC (WELD) selector is turned on.
- Under no circumstances should any type of electrical appliance be plugged into any of the AC receptacles when the selector is in the DC (WELD) position. AC voltage is present at the AC receptacle at all times, regardless of the position of the AC/DC (WELD) selector. However, when this selector is in the DC (WELD) position, the AC voltage is unregulated and fluctuates considerably.

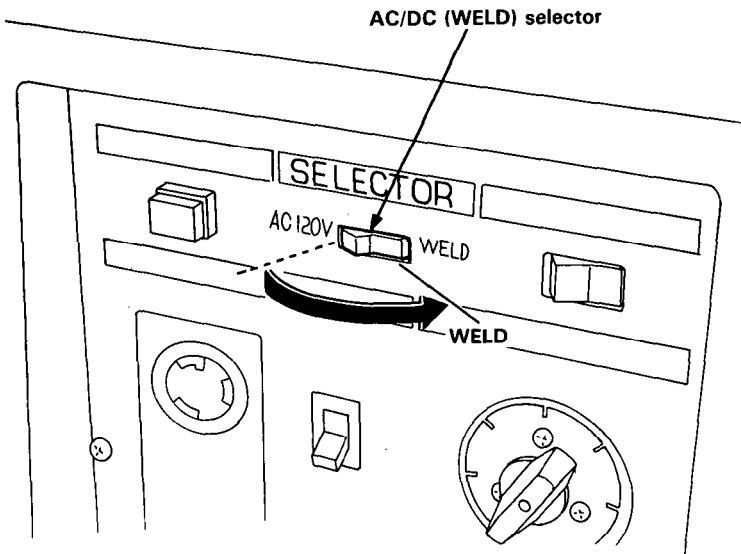

5. Set the current adjustment knob to the proper current level for the job being done (See page 23).

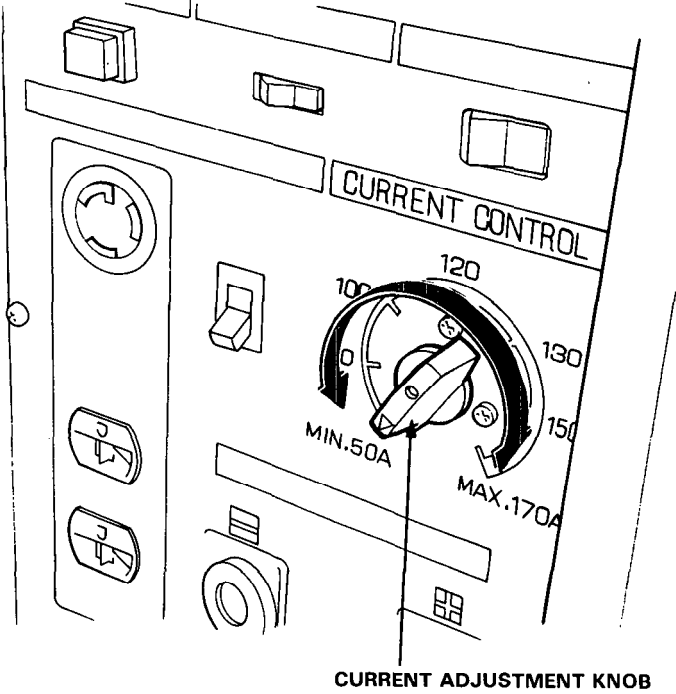

SELECTING THE CORRECT WELDING CURRENT

Measure the thickness of the metal you are welding and then refer to the table below to select the proper electrode size and current setting.

PLATE THICKNESS IN INCHES	ELECTRODE DIAMETER IN INCHES	CURRENT SETTING
UP TO 3/16	1/16	50—100
UP TO 1/4	3/32	100—150
ABOVE 1/8	1/8	125—175
ABOVE 1/4	5/32	150—200

NOTE: Always make a sample weld on a piece of scrap material to be sure you have chosen the correct electrode and current setting.

WELDING CABLE SELECTION

The table below shows the current carrying capacity of various lengths and gauges of standard copper welding cable. Whenever possible, refer to the cable manufacturer's recommendations.

Always allow a considerable safety margin when selecting welding cables. The cable's length and gauge (diameter), along with the material it is made from, all combine to determine how much current it can safely carry.

CAUTION: An undersize welding cable will offer unacceptably high resistance to current flow. This high resistance will shorten the service life of the generator/welder, and can even make the welding cables become hot enough to cause painful burns.

CABLE GAUGE	CABLE DIA.	LENGTH IN FEET *		
		0—50 FT.	50—100 FT.	100—250 FT.
CURRENT CAPACITY AMPERES				
1	.644	250	200	170
2	.604	200	195	—

NOTE: The cable lengths given in the table above are the combined lengths of the negative and positive cables.

POLARITY SELECTION

The welding terminals are labeled “+” (positive) and “-” (negative). Changing the polarity of the cables will affect the weld. The correct polarity selection is dependent on the type of electrode you are using and the type of material you are welding; refer to the electrode manufacturer’s recommendations for best results.

For straight polarity, attach the electrode cable to the negative terminal, and attach the work cable to the positive terminal. To change to reverse polarity, reverse the cables.

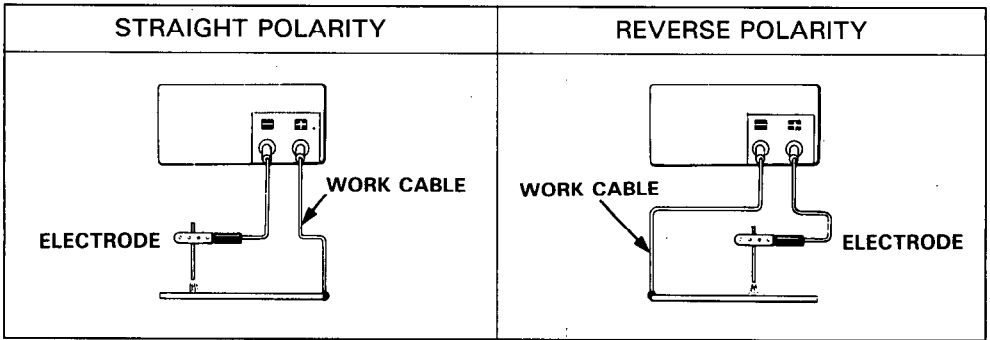

WELDING DUTY CYCLE

The duty cycle is the percentage of time that the welder can be operated in a given 10 minute period.

For example, at a rated output of 130 amperes, the EXW171S’s duty cycle is 50%. This means that at 130 amperes, welding can be performed for a total of 5 minutes out of every 10 minute period. The duty cycle is longer at lower operating currents, and shorter at higher currents.

Current	170A	150A	130A	110A	Below 90A
Rate	15%	25%	50%	65%	100%

CAUTION: Do not operate the welder beyond its duty cycle; doing so will decrease the performance and service life of the generator/welder.

6. STOPPING THE ENGINE

NOTE: To stop the engine in an emergency, turn the engine switch to the OFF position.

In normal use:

1. Move the AC circuit breaker to the OFF position.

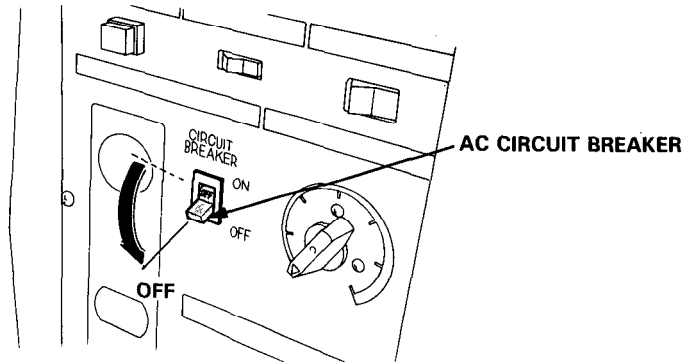

2. Turn the engine switch to the OFF position.

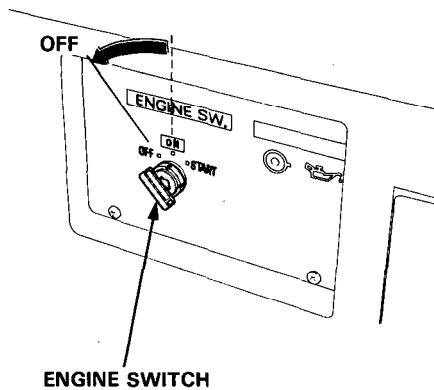

High altitude operation

At high altitude, the standard carburetor air-fuel mixture will be excessively rich. Performance will decrease, and fuel consumption will increase.

High altitude performance can be improved by installing a smaller diameter main fuel jet in the carburetor and readjusting the pilot screw. If you always operate the generator/welder at altitudes higher than 6,000 feet above sea level, have your authorized Honda Generator/Welder dealer perform these carburetor modifications.

Even with suitable carburetor jetting, engine horsepower will decrease approximately 3.5% for each 1,000 foot increase in altitude. The affect of altitude on horsepower will be greater than this if no carburetor modification is made.

CAUTION: Operation of the generator/welder at an altitude lower than the carburetor is jetted for may result in reduced performance, overheating, and seious engine damage caused by an excessively lean air/fuel mixture.

7. MAINTENANCE

Periodic maintenance and adjustment are necessary to keep the generator/welder in good operating condition. Perform the service and inspection scheduled in the table on the following page.

WARNING Shut off the engine before performing any maintenance. If the engine must be run, make sure the area is well ventilated. Exhaust contains poisonous carbon monoxide gas; exposure may cause loss of consciousness and may lead to death.

CAUTION: Use only genuine HONDA parts or their equivalent for maintenance or repair. Replacement parts which are not of equivalent quality may damage the generator/welder.

Tool kit

The tools supplied with the generator will help you to perform the owner-maintenance procedures listed on the following page. Always keep this tool kit with the generator/welder.



10 x 12 mm WRENCH



PLUG WRENCH HANDLE



SCREW DRIVER



PLUG WRENCH

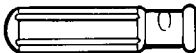

DRIVER GRIP

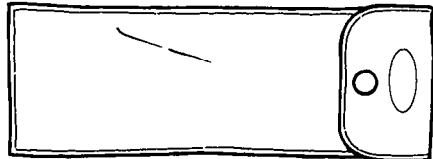

TOOL BAG

Maintenance Schedule

REGULAR SERVICE PERIOD		EACH USE	FIRST MONTH OR 20 HRS (3)	EVERY 3 MONTHS OR 50 HRS (3)	EVERY 6 MONTHS OR 100 HRS (3)	EVERY YEAR OR 300 HRS (3)
ITEM	Perform at every indicated month or operating hour interval, whichever comes first.					
Engine oil	Check level	○				
	Change		○		○	
Air cleaner	Check	○				
	Clean			○ (1)		
Battery electrolyte	Check level	○				
	Check level and gravity				○	
Sediment cup	Clean				○	
Spark plug	Clean-Readjust				○	
Spark arrester	Clean				○	
Valve clearance	Check-Readjust					○ (2)
Fuel tank and filter	Clean					○ (2)
Fuel line	Check (Replace if necessary)	Every 3 years				

NOTE: (1) Service more frequently when used in dusty areas.

(2) These items should be serviced by an authorized Honda dealer, unless the owner has the proper tools and is mechanically proficient.

See the Honda Shop Manual.

(3) For professional commercial use, log hours of operation to determine proper maintenance intervals.

Changing Oil

Drain the oil while the engine is still warm to assure rapid and complete draining.

1. Open the front maintenance cover.
2. Remove the drain bolt and filler cap, and drain the oil. Retighten the bolt securely.
3. Refill with the recommended oil (see page 9) and check the level.
4. Close and latch the front maintenance cover.

OIL CAPACITY: 1.1ℓ (1.16 US qt)

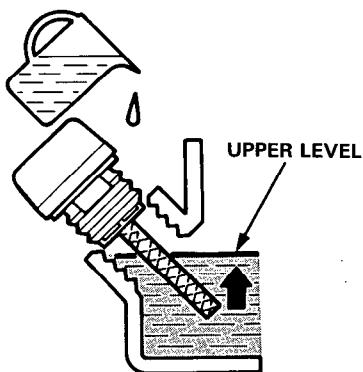
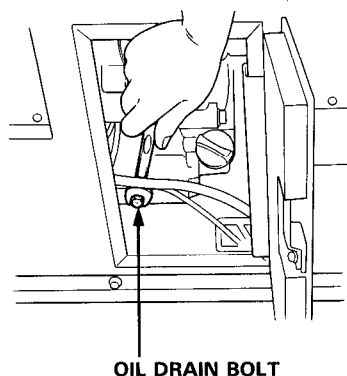

CAUTION: Used motor oil may cause skin cancer if repeatedly left in contact with the skin for prolonged periods. Although this is unlikely unless you handle used oil on a daily basis, it is still advisable to thoroughly wash your hands with soap and water as soon as possible after handling used oil.

NOTE: Please dispose of used motor oil in a manner that is compatible with the environment. We suggest you take it in a sealed container to your local service station for reclamation. Do not throw it in the trash or pour it on the ground.

Air Cleaner Service

A dirty air cleaner will restrict air flow to the carburetor. To prevent carburetor malfunction, service the air cleaner regularly (page 28). Service more frequently when operating the generator/welder in extremely dusty areas.

WARNING Never use gasoline or low flash point solvents for cleaning the air cleaner element. A fire or explosion could result.

CAUTION: Never run the generator/welder without the air cleaner. Rapid engine wear will result from contaminants, such as dust and dirt, being drawn through the carburetor, into the engine.

1. Open the rear maintenance cover.
2. Unsnap the clips and remove the air cleaner cover and air cleaner element.
3. Wash the element in a solution of household detergent and warm water, then rinse thoroughly, or wash in nonflammable or high flash point solvent. Allow the element to dry thoroughly.
4. Soak the element in clean engine oil and squeeze out the excess oil. The engine will smoke during initial start-up if too much oil is left in the element.
5. Reinstall the air cleaner element, the cover and the clips.
6. Close and latch the rear maintenance cover.

AIR CLEANER COVER

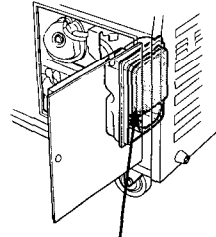
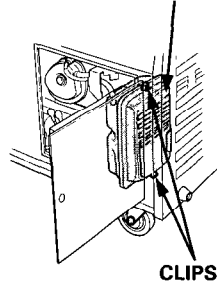

AIR CLEANER ELEMENT

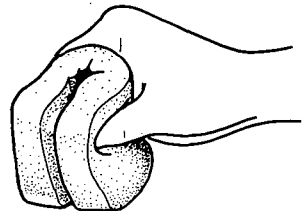

Spark Plug Service

**Recommended spark plug: BPR-5ES-11 (NGK)
W16EPR-U11 (ND)**

To ensure proper engine operation, the spark plug must be properly gapped and free of deposits.

WARNING The muffler becomes very hot during operation and remains sufficiently hot to inflict burns if touched, even after shutting off the engine.

1. Remove the spark plug cap.
2. Clean any dirt from around the spark plug base.
3. Use the wrench supplied in the tool kit to remove the spark plug.

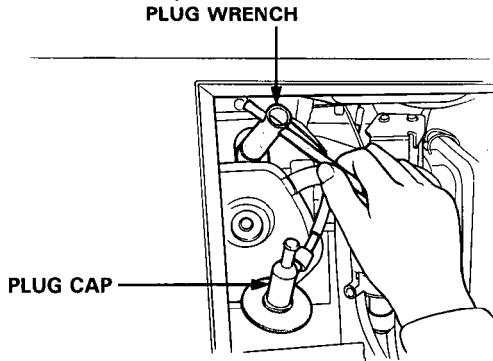

4. Visually inspect the spark plug. Discard it if the insulator is cracked or chipped. Clean the spark plug with a wire brush if it is to be reused.
5. Measure the plug gap with a feeler gauge. The gap should be 1.0–1.1 mm (0.039–0.043 in).

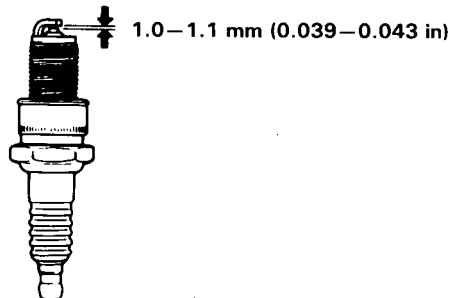

-
6. Check that the spark plug washer is in good condition, and thread the spark plug in by hand to prevent cross-threading.

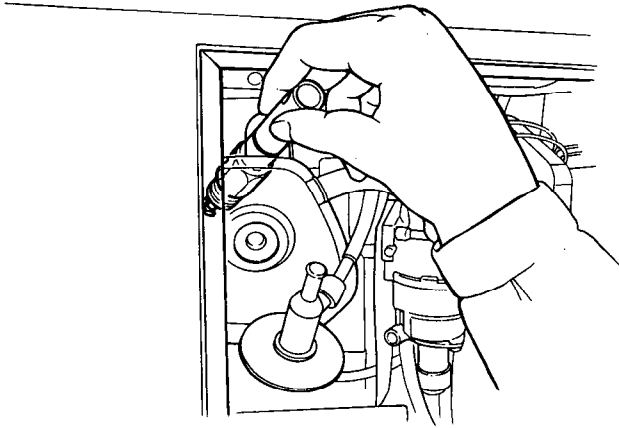

7. After the spark plug is seated, tighten with a spark plug wrench to compress the washer.

NOTE: If installing a new spark plug, tighten $1/2$ turn after the spark plug seats to compress the washer. If reinstalling a used spark plug, tighten $1/8$ — $1/4$ turn after the spark plug seats to compress the washer.

CAUTION:

- The spark plug must be securely tightened. An improperly tightened plug can become very hot and may cause engine damage.
- Use only the recommended spark plugs or equivalent. Spark plugs which have an improper heat range may cause engine damage.

Spark Arrester Maintenance

This generator/welder is equipped with a U.S.D.A. qualified spark arrester which requires periodic maintenance to ensure its effectiveness. It is illegal in some areas to operate an engine without a spark arrester; check local laws and regulations.

WARNING The muffler becomes very hot during operation and remains hot for a while after stopping the engine. Be careful not to touch the muffler while it is hot. Allow it to cool before proceeding.

CAUTION: The spark arrester must be serviced every 100 hours to maintain its efficiency.

1. Remove the right side cover and handle by removing the nine 6 mm bolts.
2. Remove the two 5 mm bolts from the spark arrester flange. Remove the flange, then remove the spark arrester from the muffler.
3. Clean the carbon deposits from the spark arrester screen with a brush. Check the spark arrester screen for damage. Replace the spark arrester if the screen is torn or punctured.
4. Reinstall the parts in the reverse order of disassembly. Tighten the bolts securely.

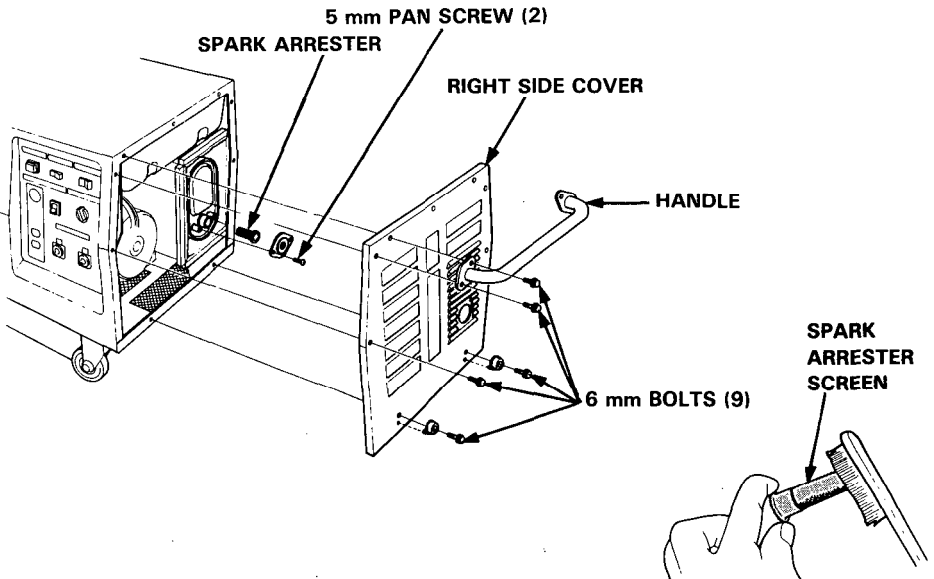

Sediment Cup Cleaning

The sediment cup prevents dirt or water which may be in the fuel tank from entering the carburetor. If the engine has not been run for a long time, the sediment cup should be cleaned.

1. Open the left side maintenance cover.
2. Turn the engine switch to the OFF position. Remove the sediment cup by turning it counterclockwise.
3. Clean the cup and O-ring in nonflammable or high flashpoint solvent.
4. Reinstall the O-ring and sediment cup. Tighten securely.
5. Close and latch the left side maintenance cover.

WARNING

- Gasoline is extremely flammable and is explosive under certain conditions.
- After installing the sediment cup, check for fuel leaks, and make sure the area is dry before starting the engine. Fuel vapor or spilled fuel may ignite.

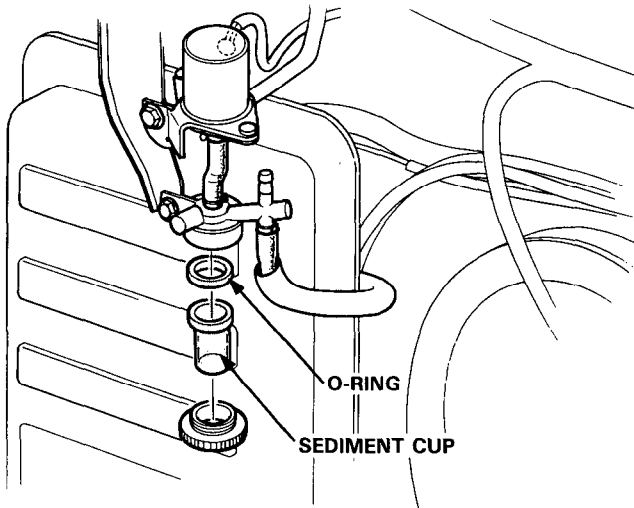

Battery Electrolyte Level Check

Open the left maintenance cover and check the electrolyte level in each battery cell. Fill the battery with distilled water to the upper level line. Never overfill the battery. Any corrosion around the positive and negative terminals should be washed off with a solution of baking soda and warm water. Dry the terminals and retighten the terminal bolts if necessary, then coat the terminals with grease.

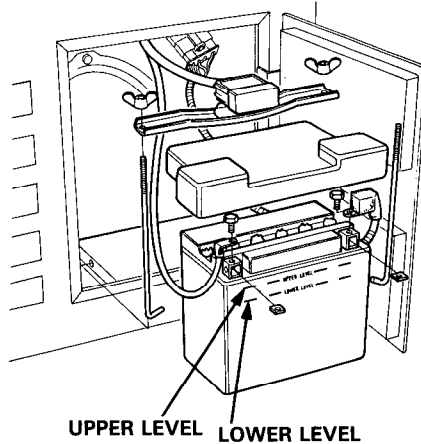

WARNING

- The battery contains sulfuric acid. Avoid contact with skin, eyes or clothing.

Antidote: EXTERNAL — Flush with water.

INTERNAL — Drink large quantities of water or milk. Follow with milk of magnesia, beaten egg or vegetable oil. Call a physician immediately.

EYES — Flush with water and get prompt medical attention.

- Batteries produce explosive gases. Keep sparks, flames and cigarettes away. Always shield the eyes when working near batteries.

CAUTION:

- Use only distilled water in the battery. Tap water will shorten the service life of the battery.
- Do not fill the battery beyond the UPPER level. If overfilled, electrolyte may overflow and corrode tractor components. Immediately wash off any spilled electrolyte.

Fuse Replacement

The fuse holder is located on the battery container.

1. Turn the engine switch to the OFF position.
2. Open the left side maintenance cover, open the fuse holder cover and replace the fuse. The specified fuses are 1A, 5A, 10A.

CAUTION:

- If frequent fuse failure occurs, determine the cause and correct the problem before attempting to operate the generator further.
- Never use a fuse with a different rating from that specified. Serious damage to the electrical system or fire may result.

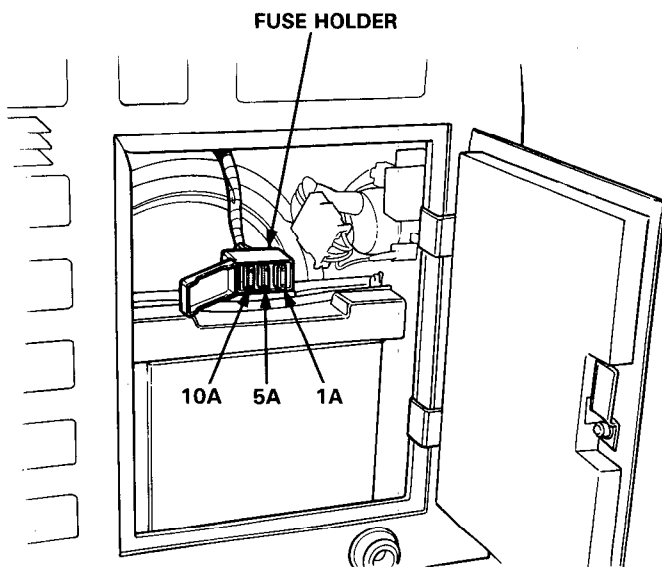

8. TRANSPORTING/STORAGE

WARNING

- To prevent severe burns or fire hazards, let the engine cool before transporting the generator/welder or storing it indoors.
- When transporting the generator/welder, turn the engine switch and the fuel valve to the OFF position, and keep the generator/welder level to prevent fuel spillage. Fuel vapor or spilled fuel may ignite.

Before storing the unit for an extended period:

1. Be sure the storage area is free of excessive humidity and dust.
2. Drain the fuel—
 - a. Open the rear maintenance cover.
 - b. Turn the engine switch to ON and then loosen the carburetor drain screw. Drain the gasoline from the carburetor and fuel tank into a suitable container.

 **WARNING** Gasoline is extremely flammable and is explosive under certain conditions. Perform this task in a well ventilated area with the engine stopped. Do not smoke or allow flames or sparks in the area during this procedure.

- c. Tighten the carburetor drain screw, turn the engine switch to OFF and close the rear maintenance cover.

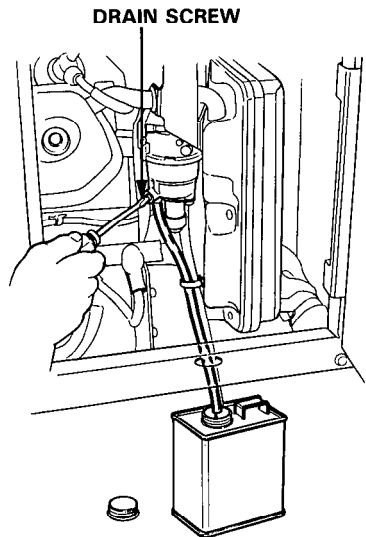

3. Once a month, recharge the battery.

CAUTION: When starting the generator after adding fuel for the first time, after long-term storage, or after running out of fuel turn the engine switch to the "ON" position, then wait for 10 to 20 seconds before starting the engine.

9. TROUBLESHOOTING

When the engine will not start:

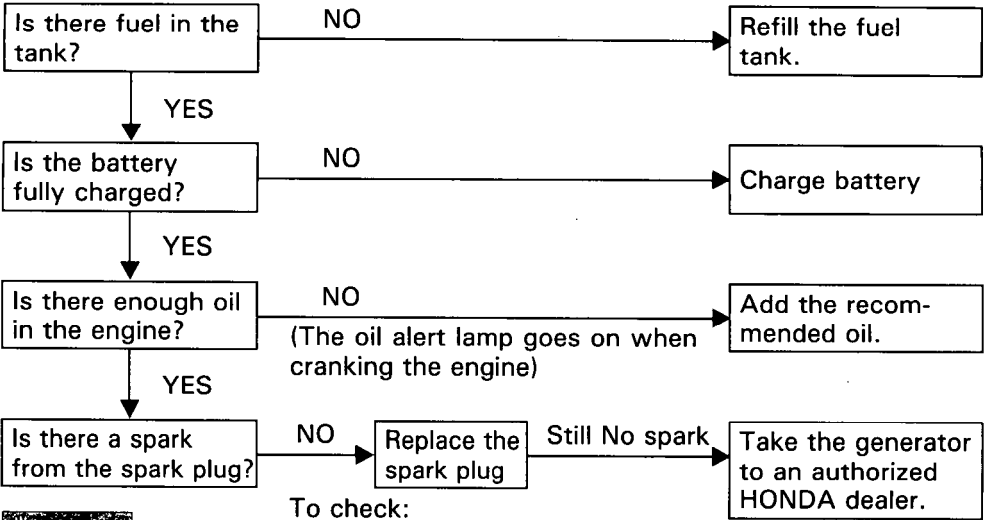

WARNING
If any fuel has been spilled, make sure the area is dry before testing the spark plug. Fuel vapor or spilled fuel may ignite. Perform this test in a well-ventilated area.

To check:

- 1) Remove the spark plug cap and clean any dirt from around the spark plug.
- 2) Remove the spark plug and install the spark plug in the plug cap.
- 3) Set the plug side electrode on the cylinder head.
- 4) Crank the engine, sparks should jump across the gap.

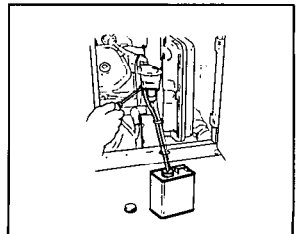
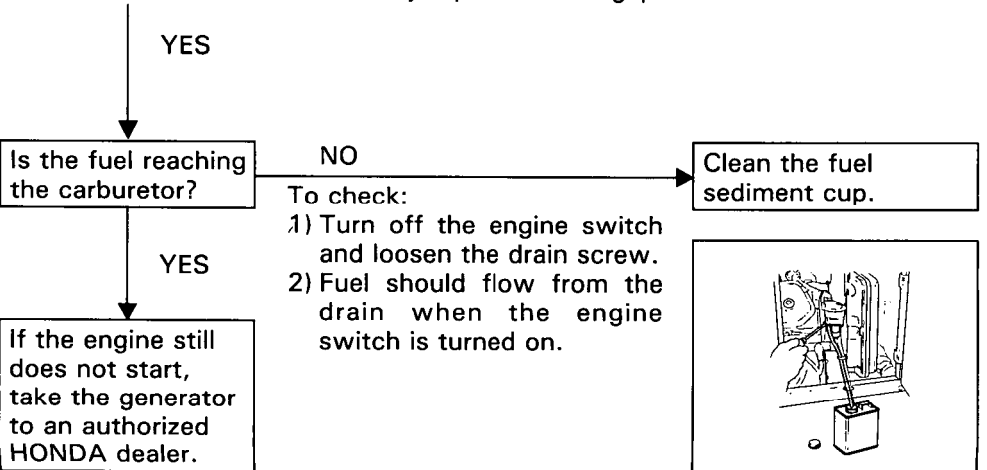
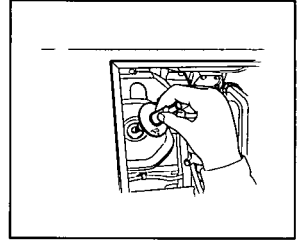

No electricity at the AC receptacles:

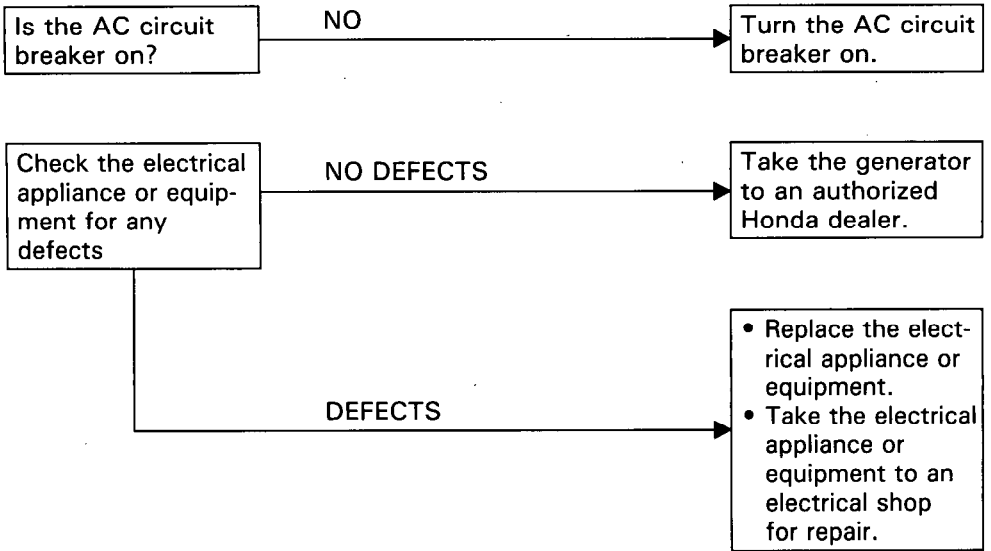

When the welding arc is weak:

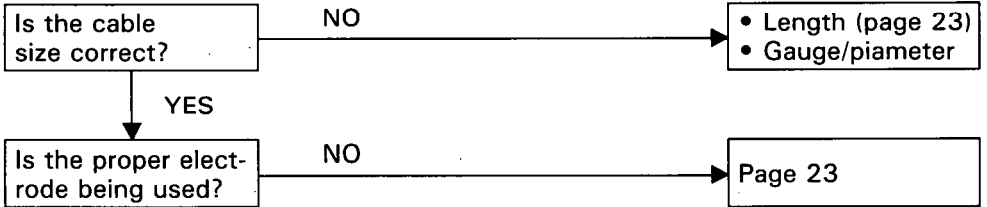

10. SPECIFICATIONS

Dimensions

Model	EXW171S
Power product description code	EB5
Length x Width x Height	910 x 530 x 695 mm (35.8 x 20.9 x 27.4 in)
Dry weight	137 kg (302.0 lb)

Engine

Engine Type	GX340
Displacement [Bore x Stroke]	337 cc (20.6 cu in) [82 x 64 mm (3.2 x 2.5 in)]
Compression Ratio	8.0 : 1
Engine Speed (rated r.p.m.)	3600 r.p.m.
Cooling System	Forced air
Ignition System	C.D.I. with electronic advancer
Oil Capacity	1.1 ℓ (1.16 US qt)
Fuel Tank Capacity	19.0 ℓ (5.0 US gal)
Spark Plug	BPR-5ES-11 (NGK), W16EPR-U11 (ND)

Generator

DC (WELDING) output	Rated current	130 A
	Rated voltage	26.5 V
	Welding current	50–170 A
	Operating rate	50% 130A
	Electrode diameter	3/32, 1/8, 5/32 in (2.6–4.0 mm)
AC output	Rated Voltage	120V
	Rated Frequency	60 Hz
	Rated Ampere	33.3 A
	Rated Output	4.0 KVA
	Maximum Output	4.0 KVA

11. WIRING DIAGRAM

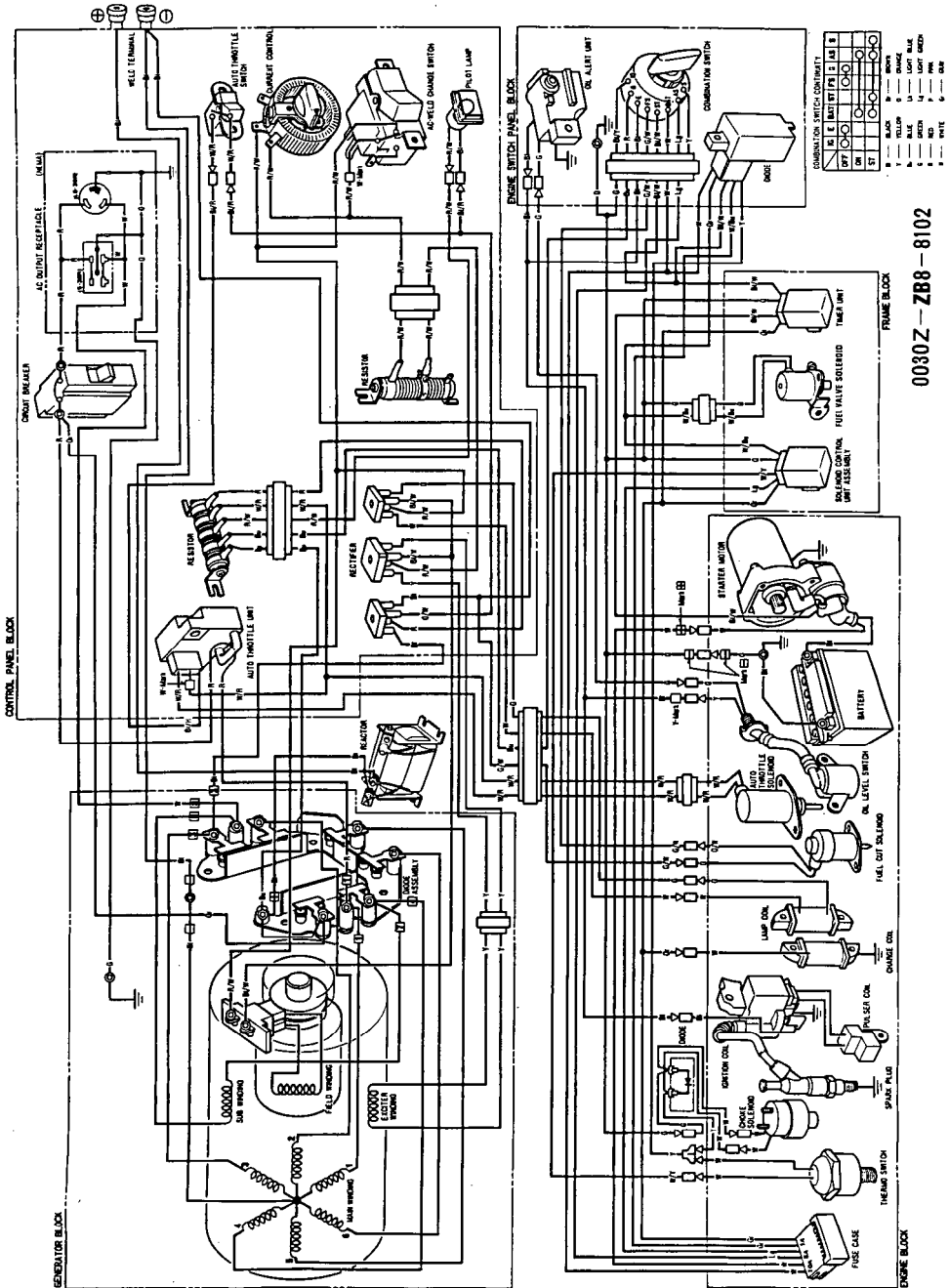

0030Z - ZB8 - 8102

ENGINE BLOCK

12. WARRANTY SERVICE

Owner Satisfaction

Your satisfaction and goodwill are important to your dealer and to us. All Honda warranty details are explained in the Distributor's Limited Warranty. Normally, any problems concerning the product will be handled by your dealer's service department. If you have a warranty problem that has not been handled to your satisfaction, we suggest you take the following action:

- Discuss your problem with a member of dealership management. Often complaints can be quickly resolved at that level. If the problem has already been reviewed with the Service Manager, contact the owner of the dealership or the General Manager.
- If your problem still has not been resolved to your satisfaction, contact the Power Equipment Customer Relations Department of American Honda Motor Co., Inc.

American Honda Motor Co., Inc.
Power Equipment Customer Relations Department
P.O. Box 50
Gardena, California 90247-0805
Telephone: (213) 604-2400

We will need the following information in order to assist you:

- Your name, address, and telephone number
- Product model and serial number
- Date of purchase
- Dealer name and address
- Nature of the problem

After reviewing all the facts involved, you will be advised of what action can be taken. Please bear in mind that your problem will likely be resolved at the dealership, using the dealer's facilities, equipment, and personnel, so it is very important that your initial contact be with the dealer.

Your purchase of a Honda product is greatly appreciated by both your dealer and American Honda Motor Co., Inc. We want to assist you in every way possible to assure your complete satisfaction with your purchase.

Current customer service contact information:

United States, Puerto Rico, and U.S. Virgin Islands:

Honda Power Equipment dealership personnel are trained professionals. They should be able to answer any question you may have. If you encounter a problem that your dealer does not solve to your satisfaction, please discuss it with the dealership's management. The Service Manager or General Manager can help. Almost all problems are solved in this way.

If you are dissatisfied with the decision made by the dealership's management, contact the Honda Power Equipment Customer Relations Office. You can write:

American Honda Motor Co., Inc.
Power Equipment Division
Customer Relations Office
4900 Marconi Drive
Alpharetta, GA 30005-8847

Or telephone: (770) 497-6400 M-F, 8:30 am - 7:00 pm EST

When you write or call, please provide the following information:

- Model and serial numbers
- Name of the dealer who sold the Honda power equipment to you
- Name and address of the dealer who services your equipment
- Date of purchase
- Your name, address, and telephone number
- A detailed description of the problem

MEMO

MEMO

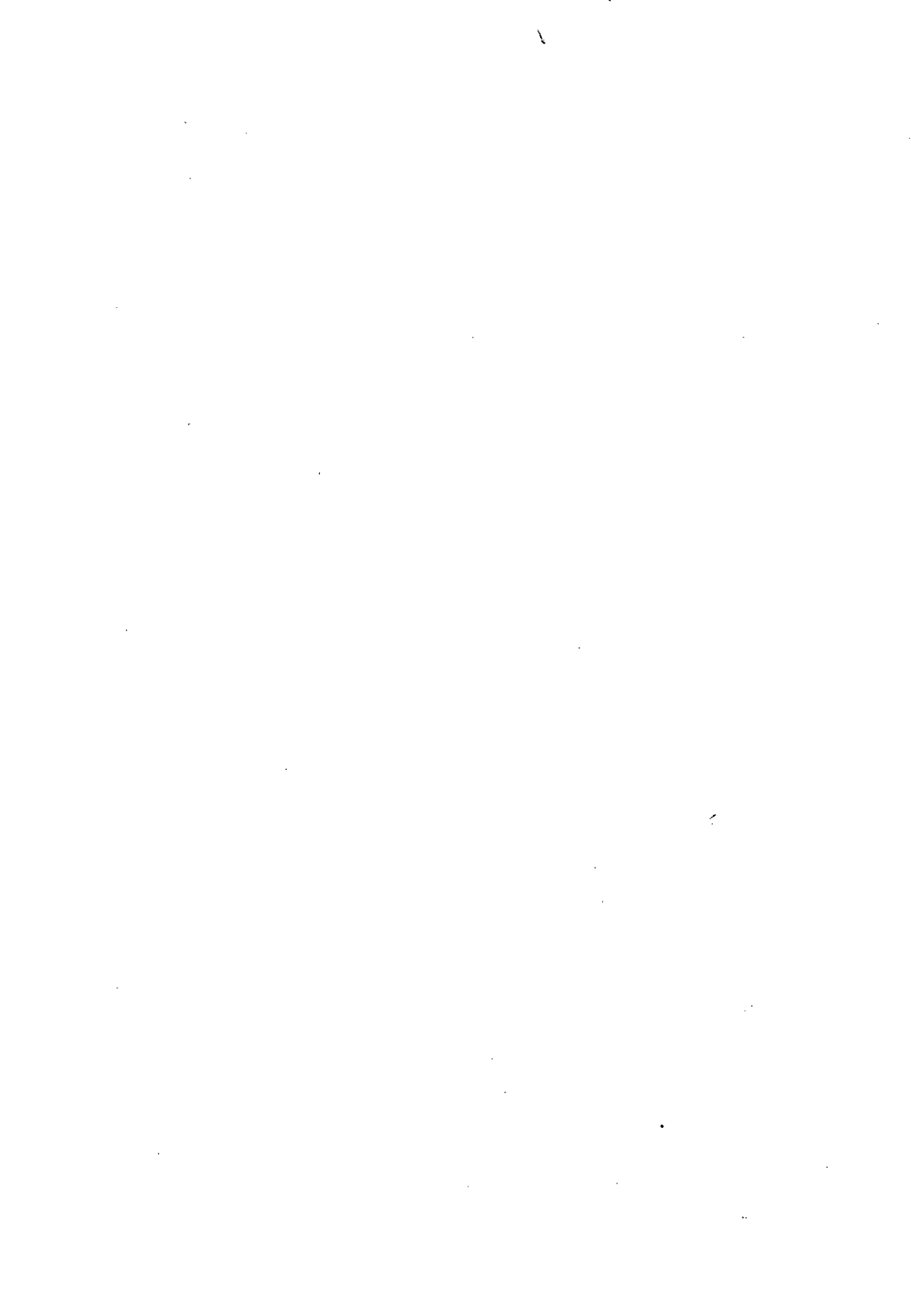



HONDA
HONDA MOTOR CO., LTD. TOKYO, JAPAN

31ZB8701
00X31-ZB8-7011

⑤ ¥5008807
PRINTED IN JAPAN