

**HONDA**

**Power**

**Equipment**

# Owner's Manual

## GENERATOR

### EB11000

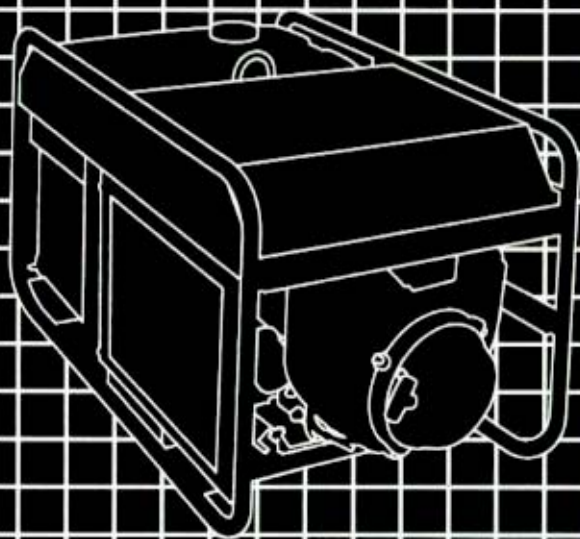



## **WARNING:**



The engine exhaust from this product contains chemicals known to the State of California to cause cancer, birth defects or other reproductive harm.

### **▲WARNING**

**The generator is a potential source of electrical shock if misused. Do not expose the generator to moisture, rain or snow. Do not let the generator get wet, and do not operate it with wet hands.**

Keep this owner's manual handy, so you can refer to it at any time. This owner's manual is considered a permanent part of the generator and should remain with the generator if resold.

The information and specifications included in this publication were in effect at the time of approval for printing. Honda Motor Co., Ltd. reserves the right, however, to discontinue or change specifications or design at any time without notice and without incurring any obligation whatever. No part of this publication may be reproduced without written permission.

---

Congratulations on your selection of a Honda generator. We are certain you will be pleased with your purchase of one of the finest generators on the market.

We want to help you get the best results from your new generator and to operate it safely. This manual contains the information on how to do that; please read it carefully.

As you read this manual, you will find information preceded by a **NOTICE** symbol. That information is intended to help you avoid damage to your generator, other property, or the environment.

We suggest you read the warranty policy to fully understand its coverage and your responsibilities of ownership. The warranty policy is a separate document that should have been given to you by your dealer.

When your generator needs scheduled maintenance, keep in mind that your Honda servicing dealer is specially trained in servicing Honda generators. Your authorized Honda servicing dealer is dedicated to your satisfaction and will be pleased to answer your questions and concerns.

Best Wishes,  
Honda Motor Co., Ltd.

---

## A FEW WORDS ABOUT SAFETY

Your safety and the safety of others are very important. And using this generator safely is an important responsibility.

To help you make informed decisions about safety, we have provided operating procedures and other information on labels and in this manual. This information alerts you to potential hazards that could hurt you or others.

Of course, it is not practical or possible to warn you about all the hazards associated with operating or maintaining a generator. You must use your own good judgement.

You will find important safety information in a variety of forms, including:

- **Safety Labels** – on the generator.
- **Safety Messages** – preceded by a safety alert symbol  and one of three signal words, DANGER, WARNING, or CAUTION.

These signal words mean:

 **DANGER**

You **WILL** be **KILLED** or **SERIOUSLY HURT** if you don't follow instructions.

 **WARNING**

You **CAN** be **KILLED** or **SERIOUSLY HURT** if you don't follow instructions.

 **CAUTION**

You **CAN** be **HURT** if you don't follow instructions.

- **Safety Headings** – such as *IMPORTANT SAFETY INFORMATION*.
- **Safety Section** – such as *GENERATOR SAFETY*.
- **Instructions** – how to use this generator correctly and safely.

This entire book is filled with important safety information – please read it carefully.

SAFETY .....	5
Safety Label Locations .....	5
Safety Information .....	7
COMPONENT IDENTIFICATION .....	9
CONTROLS .....	12
Engine Switch .....	12
Recoil Starter .....	12
Fuel Valve .....	13
Choke Knob .....	13
Circuit Breaker .....	14
Circuit Protector .....	15
Ground Fault Circuit Interrupter (GFCI) .....	16
Hour Meter .....	20
Auto-throttle Switch .....	20
Ground Terminal .....	21
Oil Alert® System .....	21
GENERATOR USE .....	22
Connections to a Building Electrical System .....	22
Ground System .....	22
Special Requirements .....	22
AC Applications .....	23
AC Operation .....	24
AC Receptacle Selection .....	25
Auto-throttle System .....	26
High Altitude Operation .....	27
PRE-OPERATION CHECK .....	28
Engine Oil .....	28
Refueling .....	29
Fuel Recommendations .....	30
Battery .....	32
STARTING THE ENGINE .....	33
STOPPING THE ENGINE .....	35

---

MAINTENANCE .....	36
The Importance of Maintenance .....	36
Maintenance Safety .....	37
Emission Control System Information .....	38
Air Index .....	40
Maintenance Schedule .....	41
Engine Oil Change .....	42
Oil Filter change .....	43
Air Cleaner Service .....	44
Spark Plug Service .....	45
Spark Arrester Maintenance .....	46
Fuel Sediment Cup Cleaning .....	47
Fuel Filter .....	48
Fuse Replacement .....	49
Battery .....	50
TRANSPORTING/STORAGE .....	61
TROUBLESHOOTING .....	62
WIRING DIAGRAM .....	63
SPECIFICATIONS .....	64
WARRANTY SERVICE INFORMATION .....	65
INDEX .....	66





## SAFETY LABEL LOCATIONS

These labels warn you of potential hazards that can cause serious injury. Read them carefully.

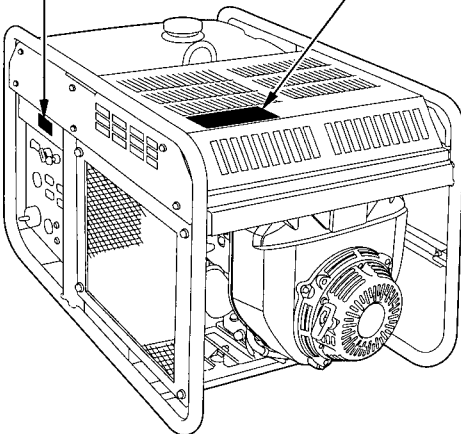
If a label comes off or becomes hard to read, contact your Honda generator dealer for a replacement.

<p><b>⚠ WARNING</b></p> <p>You risk electric shock if you operate this generator with a faulty GFCI (ground-fault circuit-interrupter).</p> <p>Test GFCI before each use.</p> <p>If GFCI fails test, do not use your generator. See your Honda dealer.</p>
--



	<p><b>⚠ WARNING</b></p> <p>GASOLINE IS HIGHLY FLAMMABLE AND EXPLOSIVE. YOU COULD BE BURNED OR SERIOUSLY INJURED IF THE GASOLINE IS IGNITED.</p> <ul style="list-style-type: none"><li>■ STOP THE ENGINE AND KEEP HEAT, SPARKS, AND FLAME AWAY.</li><li>■ HANDLE FUEL ONLY OUTDOORS.</li><li>■ DO NOT FILL THE FUEL TANK ABOVE THE UPPER LIMIT LINE.</li><li>■ WIPE UP SPILLS IMMEDIATELY.</li></ul>
	<p>EXHAUST CONTAINS POISONOUS CARBON MONOXIDE GAS THAT CAN BUILD UP TO DANGEROUS LEVELS IN CLOSED AREAS. BREATHING CARBON MONOXIDE CAN CAUSE UNCONSCIOUSNESS OR DEATH.</p> <ul style="list-style-type: none"><li>■ NEVER RUN THE GENERATOR IN A CLOSED, OR EVEN PARTLY CLOSED, AREA WHERE PEOPLE MAY BE PRESENT.</li></ul>
	<p>IMPROPER CONNECTIONS TO A BUILDING CAN ALLOW ELECTRICAL CURRENT TO BACKFEED INTO UTILITY LINES, CREATING AN ELECTROCUTION HAZARD.</p> <ul style="list-style-type: none"><li>■ CONNECTIONS TO A BUILDING MUST ISOLATE GENERATOR POWER FROM UTILITY POWER AND COMPLY WITH ALL APPLICABLE LAWS AND ELECTRICAL CODES.</li></ul>
	<p>THE GENERATOR IS A POTENTIAL SOURCE OF ELECTRICAL SHOCK IF NOT KEPT DRY.</p> <ul style="list-style-type: none"><li>■ DO NOT EXPOSE THE GENERATOR TO MOISTURE, RAIN OR SNOW.</li><li>■ DO NOT OPERATE THE GENERATOR WITH WET HANDS.</li></ul>

---

<b>⚠ CAUTION</b>	
	<b>A HOT EXHAUST SYSTEM CAN CAUSE SERIOUS BURNS.</b>
	<b>■ AVOID CONTACT IF THE ENGINE HAS BEEN RUNNING.</b>

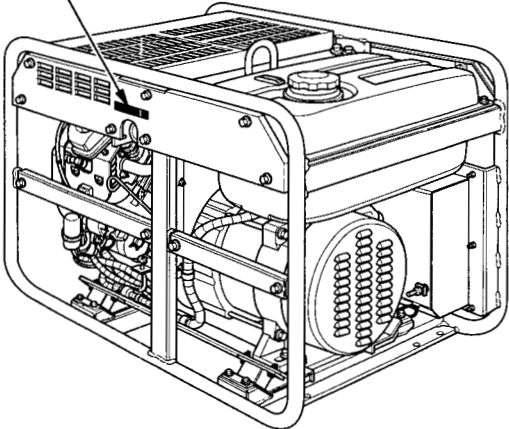

---

## **SAFETY INFORMATION**

Honda generators are designed to give safe and dependable service if operated according to instructions. Read and understand this owner's manual before operating your generator. You can help prevent accidents by being familiar with your generator's controls, and by observing safe operating procedures.

### **Operator Responsibility**

- Know how to stop the generator quickly in case of emergency.
- Understand the use of all generator controls, output receptacles, and connections.
- Be sure that anyone who operates the generator receives proper instruction. Do not let children operate the generator without parental supervision.

### **Carbon Monoxide Hazards**

- Exhaust contains poisonous carbon monoxide, a colorless and odorless gas. Breathing exhaust can cause loss of consciousness and may lead to death.
- If you run the generator in an area that is confined, or even partially enclosed, the air you breathe could contain a dangerous amount of exhaust gas. To keep exhaust gas from accumulating, provide adequate ventilation.

---

## **Electric Shock Hazards**

- The generator produces enough electric power to cause a serious shock or electrocution if misused.
- Using a generator or electrical appliance in wet conditions, such as rain or snow, or near a pool or sprinkler system, or when your hands are wet, could result in electrocution. Keep the generator dry.
- If the generator is stored outdoors, unprotected from the weather, check the Ground Fault Circuit Interrupter (GFCI), and all other electrical components on the control panel, before each use. Moisture or ice can cause a malfunction or short circuit in electrical components which could result in electrocution.
- Do not connect to a building electrical system unless an isolation switch has been installed by a qualified electrician.
- Do not connect to swimming pool equipment installed before adoption of the 1965 national electric code.

## **Fire and Burn Hazards**

- The exhaust system gets hot enough to ignite some materials.
  - Keep the generator at least 3 feet (1 meter) away from buildings and other equipment during operation.
  - Do not enclose the generator in any structure.
  - Keep flammable materials away from the generator.
- The muffler becomes very hot during operation and remains hot for a while after stopping the engine. Be careful not to touch the muffler while it is hot. Let the engine cool before storing the generator indoors.
- Gasoline is extremely flammable and is explosive under certain conditions. Do not smoke or allow flames or sparks where the generator is refueled or where gasoline is stored. Refuel in a well-ventilated area with the engine stopped.
- Fuel vapors are extremely flammable and may ignite after the engine has started. Make sure that any spilled fuel has been wiped up before starting the generator.

# COMPONENT IDENTIFICATION

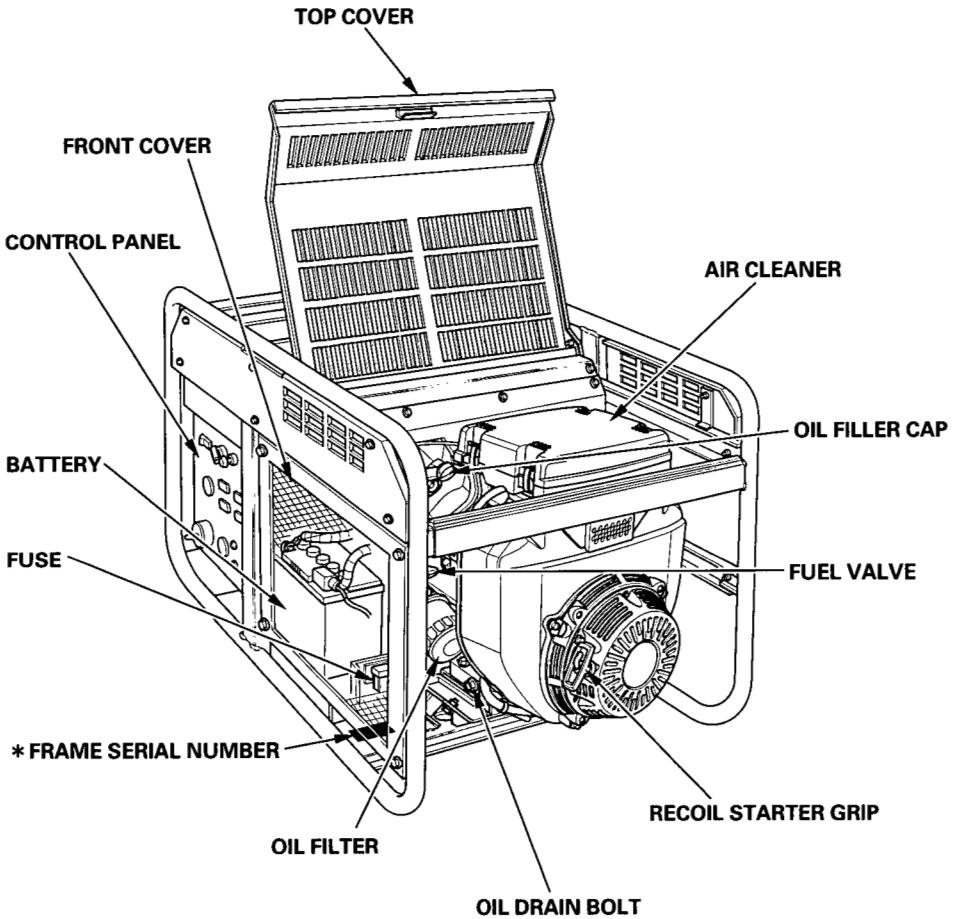

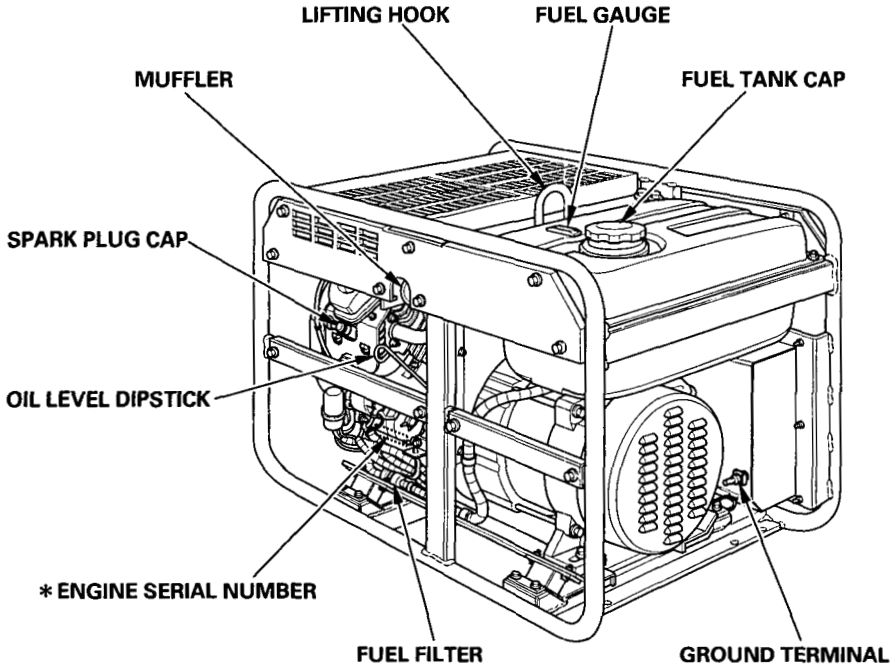

\*Record the engine and frame serial numbers for your future reference. Refer to these serial numbers when ordering parts, and when making technical or warranty inquiries (see page 65 ).

Frame serial number: \_\_\_\_\_

Engine serial number: \_\_\_\_\_

# CONTROL PANEL

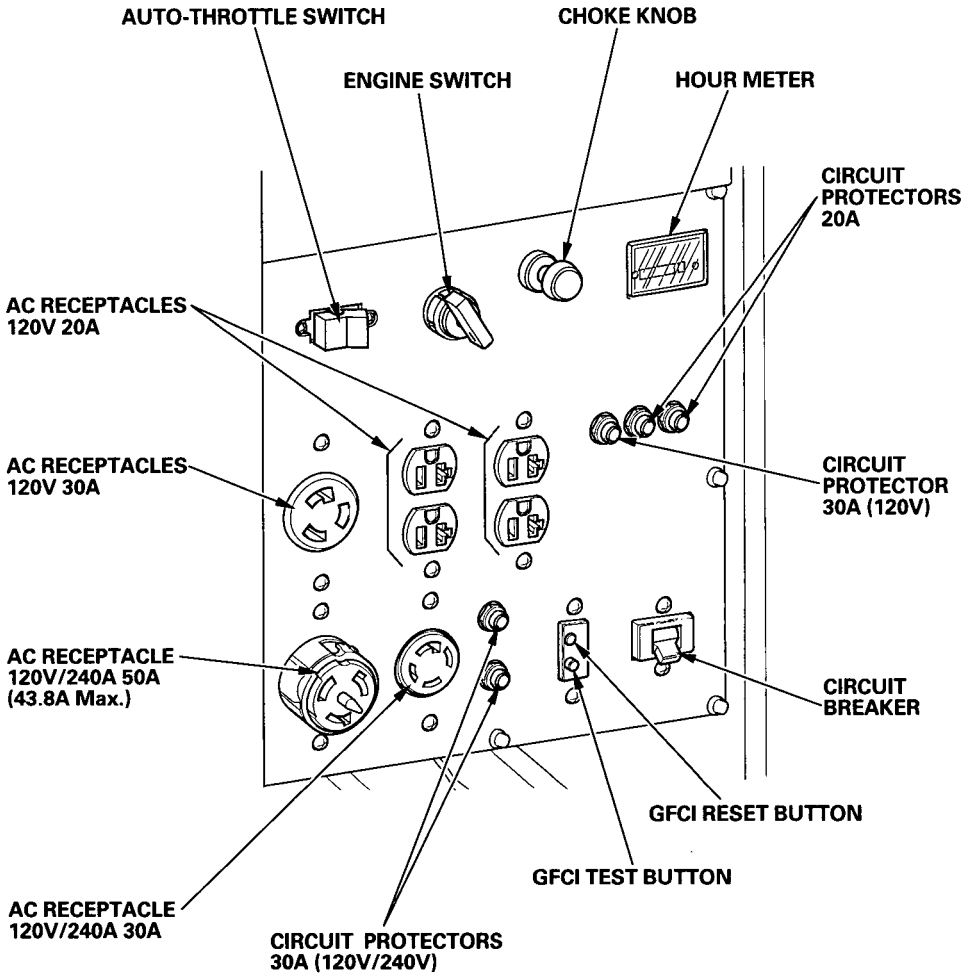

# CONTROLS

---

## ENGINE SWITCH

To start and stop the engine.

### Key position:

**OFF:** To stop the engine. Key can be removed/inserted.

**ON:** To run the engine after starting.

**START:** To start the engine by operating the starter motor.

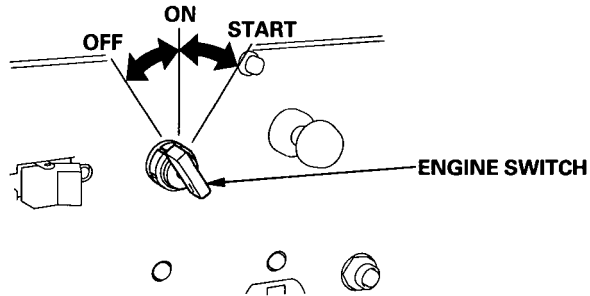

Return the key to the ON position once the engine has started. Do not use the starter for more than 5 seconds at a time. If the engine fails to start, release the switch and wait 10 seconds before operating the starter again.

## RECOIL STARTER

To start the engine, pull the starter grip lightly until resistance is felt, then pull briskly.

### NOTICE

**Do not allow the starter grip to snap back against the engine. Return it gently to prevent damage to the starter.**

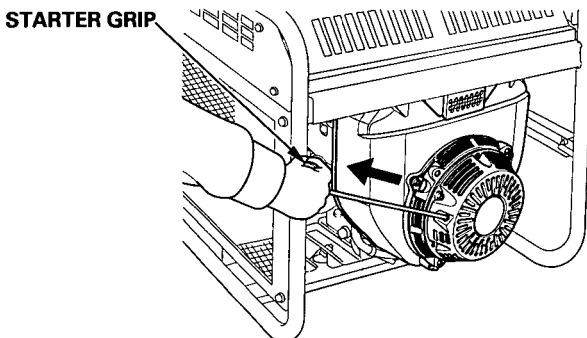

---

## FUEL VALVE

The fuel valve is located between the fuel tank and carburetor. When the valve lever is in the ON position, fuel is allowed to flow from the fuel tank to the carburetor. Be sure to return the fuel valve lever to the OFF position after stopping the engine.

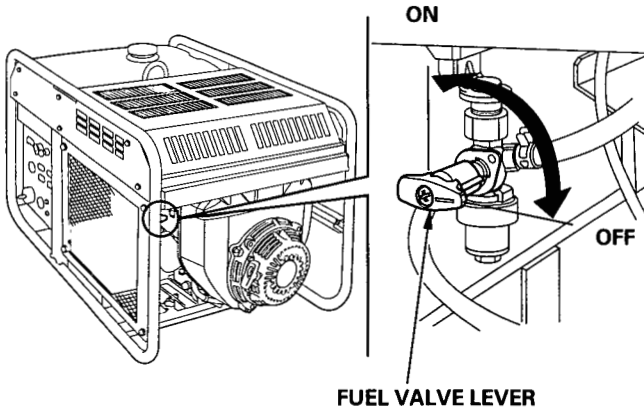

## CHOKE KNOB

The choke knob opens and closes the choke valve in the carburetor.

Pulling the choke knob to the CLOSED position enriches the fuel mixture for starting a cold engine.

Pushing the choke knob to the OPEN position provides the correct fuel mixture for operation after starting, and for restarting a warm engine.

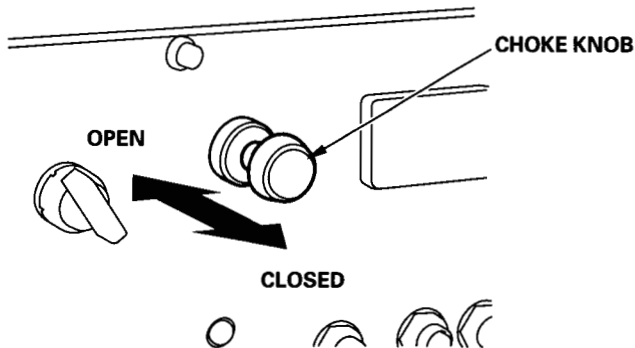

---

## CIRCUIT BREAKER

The circuit breaker will automatically switch OFF if there is a short circuit or a significant overload of the generator at the receptacle, or if the ground-fault circuit interrupter (GFCI) detects a ground-fault current.

Check the following if the circuit breaker switches OFF automatically:

- When the GFCI RESET button is extended (page 18):
  - Unplug all appliances from the receptacle and check the appliance for any defects as described in TROUBLESHOOTING (page 62).

After making repairs, push the GFCI RESET button then turn the circuit breaker ON.

- When the GFCI RESET button is not extended:
  - Check that the appliance is working properly and does not exceed the rated load capacity of the circuit before switching the circuit breaker ON again.

The AC circuit breaker may be used to switch the generator AC power ON or OFF.

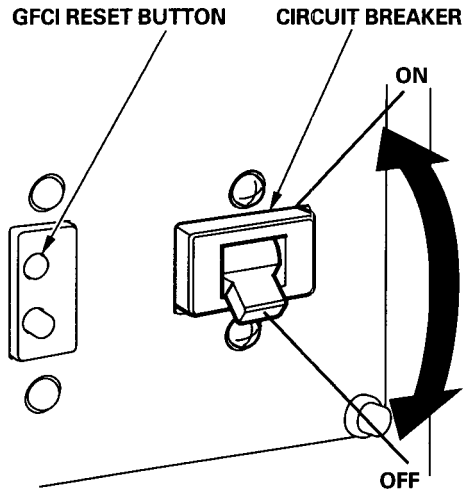

## CIRCUIT PROTECTOR

The circuit protectors will automatically switch OFF if there is a short circuit or a significant overload of the generator at the 120V 20A, 120V 30A locking plug, or 120/240V 30A locking plug receptacle. If a circuit protector switches OFF automatically, check that the appliance is working properly and does not exceed the rated load capacity of the circuit before resetting the circuit protector to the ON position.

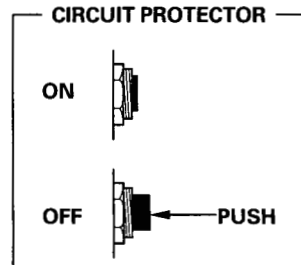
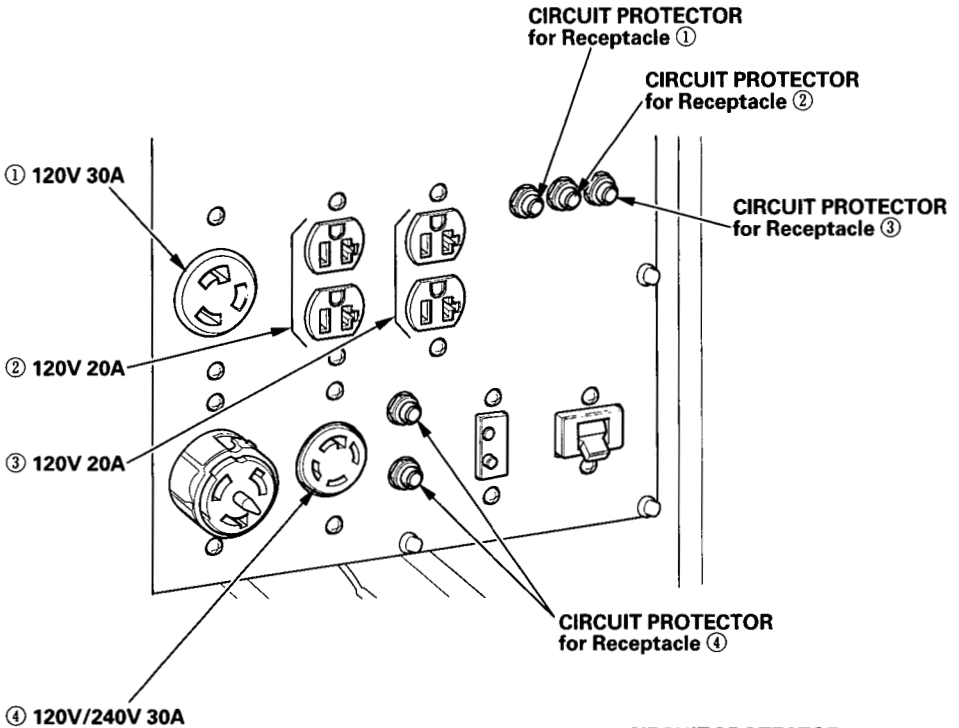

---

## GROUND FAULT CIRCUIT INTERRUPTER (GFCI)

### **▲WARNING**

**Using the generator in rain, snow or near water can lead to death from electric shock. Keep the generator dry.**

All receptacles on the generator are protected by a ground-fault circuit interrupter (GFCI) for protection against the shock hazard of ground-fault current. The GFCI has TEST and RESET buttons and is connected to the circuit breaker.

An example of ground-fault current is the current which would flow through a person who is using an appliance with faulty insulation and, at the same time, is in contact with an electrical ground such as a plumbing fixture, wet floor, or earth.

The ground-fault circuit interrupter will not protect against short circuits or overloads. The circuit breaker in the control panel which supplies power to the circuit provides that protection (refer to circuit breaker on page 14 ).

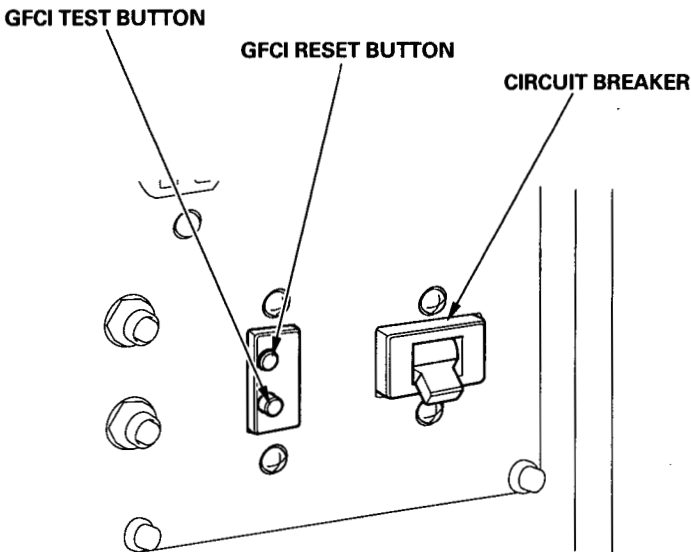

---

Observe the following precautions to ensure proper GFCI operation and to reduce shock hazards:

- Use grounded 3-conductor extension cords, tools, and appliances, or double-insulated tools and appliances.
- Inspect cords and plugs, and replace if damaged.
- Do not use cord lengths greater than 164 feet (50 meters), and do not use multiple tools and appliances with built-in noise filters. Such use may activate the GFCI and trip the circuit breaker.

---

## Inspection:

Always check GFCI operation before using the generator.

### **⚠ WARNING**

**You risk electric shock if you operate this generator with a faulty GFCI (ground-fault circuit interrupter).**

**Test GFCI before use.**

**If GFCI fails test, do not use your generator. See your Honda dealer.**

1. Unplug all tools and appliances from the generator.
2. Start the engine.
3. Turn the circuit breaker to the ON position.
4. Turn the autothrottle switch to the OFF position.
5. Press the GFCI TEST button. The RESET button should extend, and the circuit breaker should switch to the OFF position.

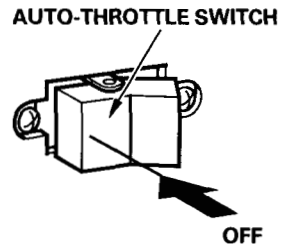

If the GFCI and circuit breaker do not function as described, take the generator to an authorized Honda generator dealer for repair.

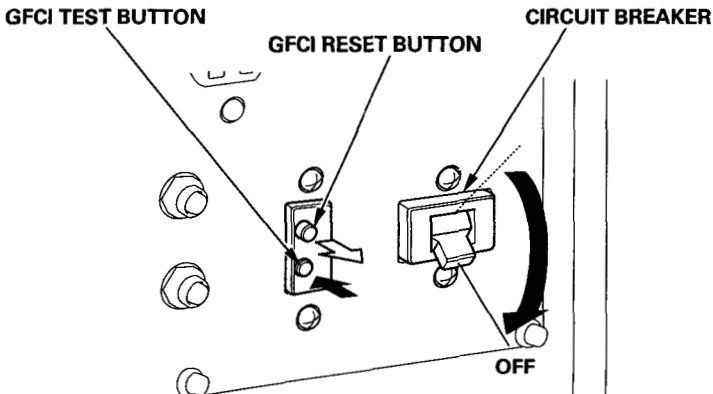

---

6. Press the GFCI RESET button. The RESET button should stay in, flush with its base plate.

With the RESET button in and engine running, turn the circuit breaker to the ON position. The circuit breaker should remain in the ON position. The circuit breaker will not remain in the ON position if the RESET button is extended.

If the GFCI and circuit breaker do not function as described, take the generator to an authorized Honda generator dealer for repair.

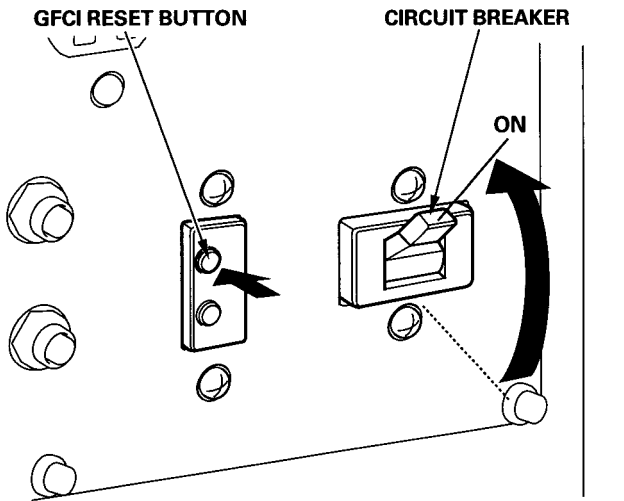

During generator use, if the GFCI RESET button extends and the circuit breaker trips, this usually indicates a faulty power tool, appliance, or load.

If that occurs, perform test steps 1 through 6 to verify that the GFCI and circuit breaker are in proper working order. If the GFCI and circuit breaker test correctly, then you will know that the fault is in the power tool, appliance, or cord. Repair or replace the faulty power tool, appliance, or cord before further use.

---

## HOUR METER

The hour meter indicates the hours the generator has been operated. Use it to determine when scheduled maintenance should be performed (see page41).

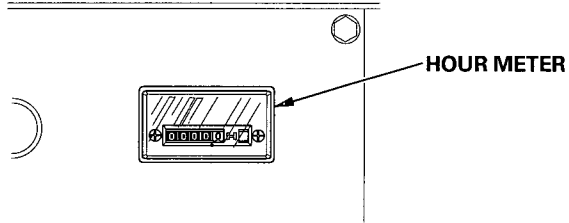

## AUTO-THROTTLE SYSTEM

The auto-throttle system automatically reduces engine speed when all loads are turned off or disconnected. When appliances are turned on or reconnected, the engine returns to the rated speed.

**ON:** Recommended to minimize fuel consumption and further reduce noise levels when no load is applied to the generator.

**OFF:** The auto-throttle system does not operate. Recommended to minimize warm-up time when the generator is started.

Leave the switch in the OFF position when using appliances that require only momentary power, that have a power demand of less than 1 ampere, or that have large startup power demands (see page26).

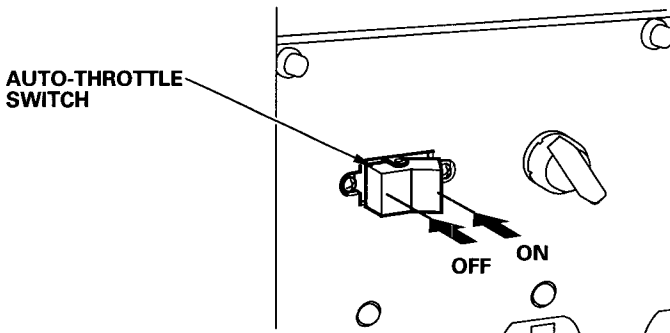

---

## GROUND TERMINAL

The generator ground terminal is connected to the frame of the generator, the metal non-current-carrying parts of the generator, and the ground terminals of each receptacle.

Before using the ground terminal, consult a qualified electrician, electrical inspector or local agency having jurisdiction for local codes or ordinances that apply to the intended use of the generator.

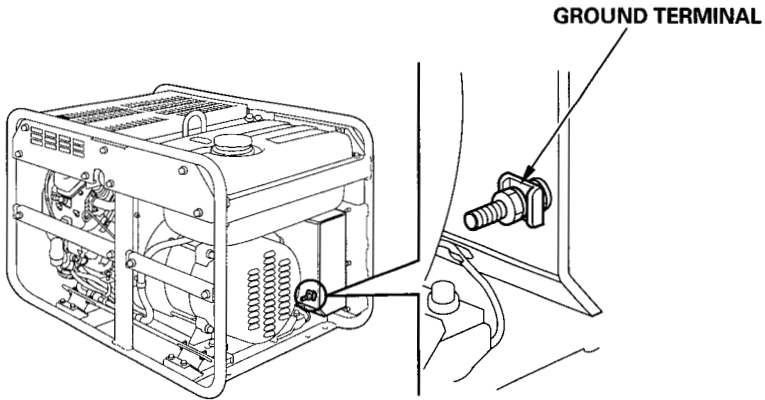

## OIL ALERT® SYSTEM

The Oil Alert® system is designed to prevent engine damage caused by an insufficient amount of oil in the crankcase. Before the oil level in the crankcase can fall below a safe limit, the Oil Alert® system will automatically stop the engine (the engine switch will remain in the ON position).

If the engine stops and will not restart, check the engine oil level (see page 28 ) before troubleshooting in other areas.

# GENERATOR USE

---

## CONNECTIONS TO A BUILDING ELECTRICAL SYSTEM

You should contact a servicing Honda generator dealer for important information before using the EB11000 with a transfer switch.

Connections for standby power to a building electrical system must be made by a qualified electrician. The connection must isolate the generator power from utility power, and must comply with all applicable laws and electrical codes. A transfer switch, which isolates generator power from utility power, is available through authorized Honda generator dealers.

### **▲WARNING**

**Improper connections to a building electrical system can allow electrical current from the generator to backfeed into the utility lines. Such backfeed may electrocute utility company workers or others who contact the lines during a power outage, and the generator may explode, burn, or cause fires when utility power is restored. Consult the utility company or a qualified electrician.**

## GROUND SYSTEM

Honda portable generators have a system ground that connects generator frame components to the ground terminals in the AC output receptacles. The system ground is connected to the AC neutral wire.

## SPECIAL REQUIREMENTS

There may be Federal or State Occupational Safety and Health Administration (OSHA) regulations, local codes, or ordinances that apply to the intended use of the generator. Please consult a qualified electrician, electrical inspector, or the local agency having jurisdiction.

- In some areas, generators are required to be registered with local utility companies.
- If the generator is used at a construction site, there may be additional regulations which must be observed.

---

## AC APPLICATIONS

Before connecting an appliance or power cord to the generator:

- Make sure that it is in good working order. Faulty appliances or power cords can create a potential for electrical shock.
- If an appliance begins to operate abnormally, becomes sluggish or stops suddenly, turn it off immediately. Disconnect the appliance, and determine whether the problem is the appliance, or if the rated load capacity of the generator has been exceeded.
- Make sure that the electrical rating of the tool or appliance does not exceed that of the generator. Never exceed the maximum power rating of the generator. Power levels between rated and maximum may be used for no more than 30 minutes.

### NOTICE

**Substantial overloading may switch off the AC circuit breaker. Exceeding the time limit for maximum power operation or slightly overloading the generator may not switch the AC circuit breaker OFF, but will shorten the service life of the generator.**

Limit operation requiring maximum power to 30 minutes.  
Maximum output is: 10.5 kVA

For continuous operation, do not exceed the rated power.  
Rated output is: 9.5 kVA

The total power requirements (VA) of all appliances connected must be considered. Appliance and power tool manufacturers usually list rating information near the model number or serial number.

---

## AC OPERATION

Check GFCI operation before each use (see page 18 ).

1. Start the engine (see page33).
2. Make sure that the GFCI RESET button is pushed in (flush with its base plate).
3. Switch ON the AC circuit breaker.
4. Plug in the appliance.

Most motorized appliances require more than their rated wattage for startup.

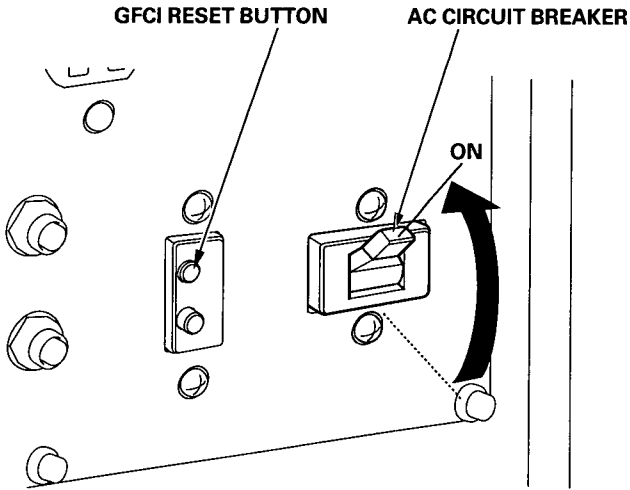

Do not exceed the current limit specified for any one receptacle. If an overloaded circuit causes the AC circuit breaker or circuit protector to switch OFF, reduce the electrical load on the circuit, wait a few minutes and then reset the circuit breaker.

## AC RECEPTACLE SELECTION

The generator has separate main power producing circuits. These two circuits supply equal power to different receptacles shown.

Main power circuit	Receptacles powered by each main circuit	Power distribution
Main Circuit I	1, 4 and 6	$1 + 4 + 6 = 39.6A$ rated.
Main Circuit II	2, 3, 5 and 7	$2 + 3 + 5 + 7 = 39.6A$ rated.

- The table shows the specifications when the 120/240V locking plug receptacle is used for 120V.

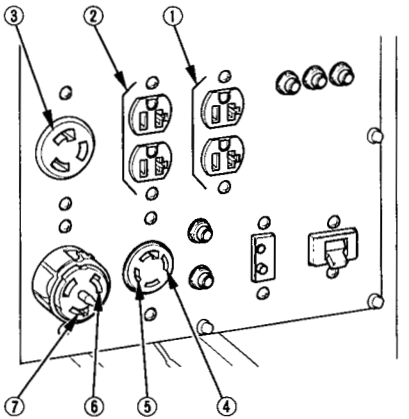

- ① 120V 20A (20A Max. for pair)
- ② 120V 20A (20A Max. for pair)
- ③ 120V 30A
- ④ & ⑤ 120V/240V 30A
- ⑥ & ⑦ 120V/240V 50A (43.8A Max.)

Example:

Receptacle 2 has a 17A load connected to it. Receptacle 3 has a 28A load connected to it. Both receptacles are powered by main power circuit II. The equation tells us that the total power draw on circuit II is 45A. This is a substantial overload of this circuit. To eliminate the excess power draw on circuit II, the load from receptacle 2 should be switched to receptacle 1. Now circuit I is powering the 17A load (less than 39.6A) and circuit II is powering a 28A load (less than 39.6A).

---

## Auto-throttle System

With the switch in the ON position, engine speed is automatically reduced when all loads are turned off or disconnected. When appliances are turned on or reconnected, the engine returns to rated speed. In the OFF position, the auto-throttle system does not operate.

The auto-throttle system will not respond to electrical loads of less than 1 ampere. Turn the auto-throttle to the OFF position to operate loads of less than 1 amp.

Appliances with large start-up power demands may not allow the engine to reach normal operating rpm when they are connected to the generator. Turn the auto-throttle to the OFF position and connect the appliance to the generator. If the engine still will not reach normal operating speed, check that the appliance does not exceed the rated load capacity of the generator.

To avoid extended warm-up periods, keep the switch OFF until the engine reaches operating temperature.

The auto-throttle system is not effective for use with appliances that require only momentary power. If the tool or appliance will be turned on and off quickly, the auto-throttle switch should be in the OFF position.

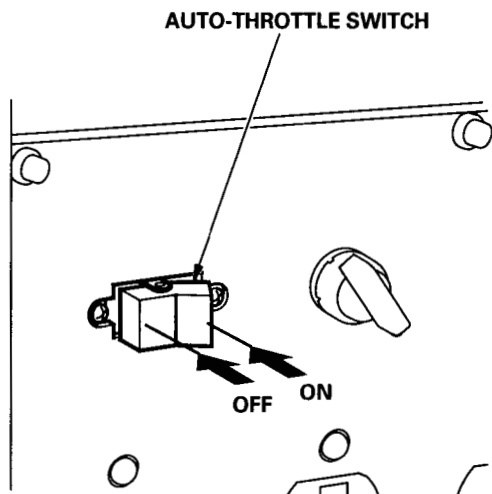

---

## HIGH ALTITUDE OPERATION

At high altitude, the standard carburetor air-fuel mixture will be too rich. Performance will decrease, and fuel consumption will increase. A very rich mixture will also foul the spark plug and cause hard starting. Operation at an altitude that differs from that at which this engine was certified, for extended periods of time, may increase emissions.

High altitude performance can be improved by specific modifications to the carburetor. If you always operate your generator at altitudes above 5,000 feet (1,500 meters), have your servicing dealer perform this carburetor modification. This engine, when operated at high altitude with the carburetor modifications for high altitude use, will meet each emission standard throughout its useful life.

Even with carburetor modification, engine horsepower will decrease about 3.5% for each 1,000-foot (300-meter) increase in altitude. The effect of altitude on horsepower will be greater than this if no carburetor modification is made.

### NOTICE

**When the carburetor has been modified for high altitude operation, the air-fuel mixture will be too lean for low altitude use. Operation at altitudes below 5,000 feet (1,500 meters) with a modified carburetor may cause the engine to overheat and result in serious engine damage. For use at low altitudes, have your servicing dealer return the carburetor to original factory specifications.**

# PRE-OPERATION CHECK

## ENGINE OIL

Check the oil level BEFORE EACH USE with the generator on a level surface and the engine stopped.

Use 4-stroke motor oil that meets or exceeds the requirements for API service classification SJ. Always check the API SERVICE label on the oil container to be sure it includes the letters SJ.

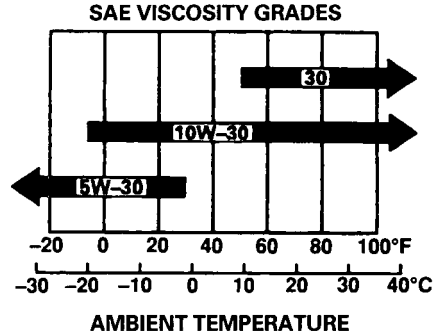

SAE 10W-30 is recommended for general, all-temperature use. Other viscosities shown in the chart may be used when the average temperature in your area is within the indicated range.

### NOTICE

**Engine oil is a major factor affecting engine performance and service life. Non detergent and 2-stroke engine oils will damage the engine and are not recommended.**

1. Position generator on a flat, level surface.
2. Remove the dipstick and wipe it clean.
3. Fully insert the dipstick, then remove it to check the oil level.
4. If the level is near or below the lower limit mark on the dipstick, remove the oil filler cap, and fill with the recommended oil to the upper limit mark.
5. Reinstall the dipstick and filler cap.

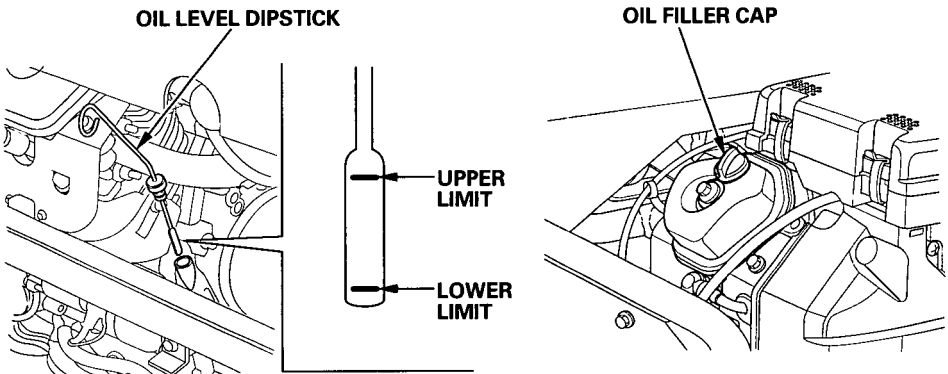

---

## REFUELING

**Fuel tank capacity:** 6.9 US gal (26 ℓ , 5.7 Imp gal)

With the engine stopped, check the fuel level gauge. Refill the fuel tank if the fuel level is low.

**▲WARNING**

**Gasoline is highly flammable and explosive. You can be burned or seriously injured when handling fuel.**

- **Stop the engine and keep heat, sparks, and flame away.**
- **Handle fuel only outdoors.**
- **Wipe up spills immediately.**

Refuel in a well-ventilated area with the engine stopped. If the engine has been running, allow it to cool first. Refuel carefully to avoid spilling fuel. Do not fill above the upper limit. After refueling, tighten the fuel tank cap securely.

Never refuel the engine inside a building where gasoline fumes may reach flames or sparks. Keep gasoline away from appliance pilot lights, barbecues, electric appliances, power tools, etc.

Spilled fuel is not only a fire hazard, it causes environmental damage. Wipe up spills immediately.

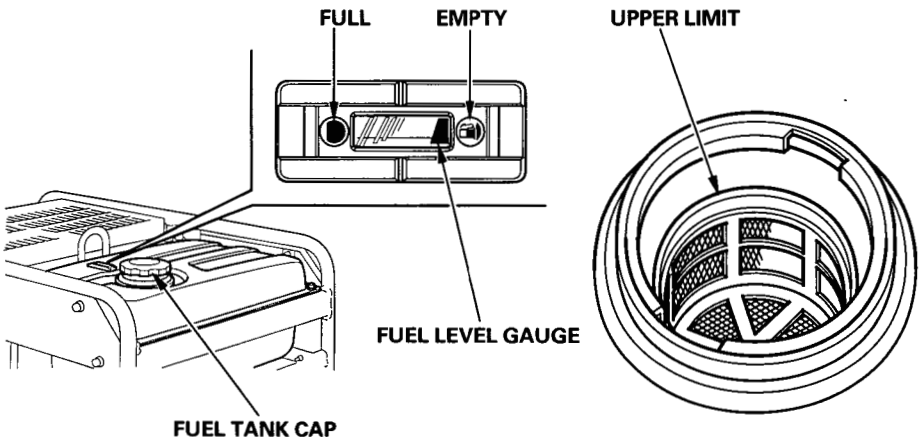

---

## FUEL RECOMMENDATIONS

Use unleaded gasoline with a pump octane rating of 86 or higher.

This engine is certified to operate on unleaded gasoline. Unleaded gasoline produces fewer engine and spark plug deposits and extends exhaust system life.

Never use stale or contaminated gasoline or an oil/gasoline mixture. Avoid getting dirt or water in the fuel tank.

Occasionally you may hear a light “spark knock” or “pinging” (metallic rapping noise) while operating under heavy loads. This is no cause for concern.

If spark knock or pinging occurs at a steady engine speed, under normal load, change brands of gasoline. If spark knock or pinging persists, see an authorized Honda generator dealer.

### NOTICE

**Running the engine with persistent spark knock or pinging can cause engine damage.**

Running the engine with persistent spark knock or pinging is misuse, and the *Distributor's Limited Warranty* does not cover parts damaged by misuse.

---

## Oxygenated Fuels

Some conventional gasolines are being blended with alcohol or an ether compound. These gasolines are collectively referred to as oxygenated fuels. To meet clean air standards, some areas of the United States and Canada use oxygenated fuels to help reduce emissions.

If you use an oxygenated fuel, be sure it is unleaded and meets the minimum octane rating requirement.

Before using an oxygenated fuel, try to confirm the fuel's contents. Some states/provinces require this information to be posted on the pump.

The following are the EPA approved percentages of oxygenates:

**ETHANOL** — (ethyl or grain alcohol) 10% by volume  
You may use gasoline containing up to 10% ethanol by volume. Gasoline containing ethanol may be marketed under the name "Gasohol".

**MTBE** — (methyl tertiary butyl ether) 15% by volume  
You may use gasoline containing up to 15% MTBE by volume.

**METHANOL** — (methyl or wood alcohol) 5% by volume  
You may use gasoline containing up to 5% methanol by volume as long as it also contains cosolvents and corrosion inhibitors to protect the fuel system. Gasoline containing more than 5% methanol by volume may cause starting and/or performance problems. It may also damage metal, rubber, and plastic parts of your fuel system.

If you notice any undesirable operating symptoms, try another service station or switch to another brand of gasoline.

Fuel system damage or performance problems resulting from the use of an oxygenated fuel containing more than the percentages of oxygenates mentioned above are not covered under warranty.

---

## BATTERY

The electrolyte level must be kept between the UPPER and LOWER level marks.

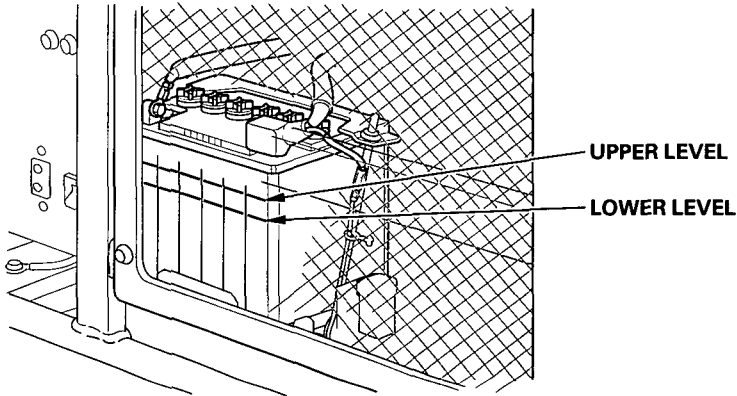

If the electrolyte level is near the LOWER level, remove the battery filler caps and carefully add distilled water to the upper level line (see page 52 ).

### **▲WARNING**

**The battery contains sulfuric acid (electrolyte) which is highly corrosive and poisonous.**

**Getting electrolyte in your eyes or on your skin can cause serious burns.**

**Wear protective clothing and eye protection when working near the battery.**

### **EMERGENCY PROCEDURES:**

**Eyes**—Flush with water from a cup or other container for at least 15 minutes (water under pressure can damage the eye). Immediately call a physician, local poison control, or 911.

**Skin**—Remove contaminated clothing. Flush the skin with large quantities of water. Call a physician immediately.

**Swallowing**—Drink water or milk. Call your local poison control center or a physician immediately.

# STARTING THE ENGINE

---

## STARTING THE ENGINE

### Electric starting:

1. Make sure that the AC circuit breaker is in the OFF position. The generator may be hard to start if a load is connected.
  2. Turn the fuel valve lever to the ON position.
  3. Select the choke knob position.
    - A cold engine:  
Pull the choke knob to the CLOSED position.
    - A warm engine:  
Leave the choke knob in the OPEN position. If the engine does not start, pull the choke knob to the CLOSED position.
  4. Make sure the auto-throttle switch is in the OFF position, or more time will be required for warm up.
  5. Turn the engine switch to the START position and hold it there for 5 seconds or until the engine starts.
- NOTICE**
- **Operating the starter motor for more than 5 seconds can damage the motor. If the engine fails to start, release the switch and wait 10 seconds before operating the starter again.**
  - **If the speed of the starter motor drops after a period of time, it is an indication that the battery should be recharged.**
6. When the engine starts, allow the engine switch to return to the ON position.
  7. If the choke knob was moved to the CLOSED position to start the engine, push the choke knob to the OPEN position as the engine warms up.
  8. If you wish to use the auto-throttle system, turn the auto-throttle switch to the ON position after the engine has warmed up for 2 or 3 minutes.

---

### **Pull starting:**

1. Make sure that the AC circuit breaker is in the OFF position. The generator may be hard to start if a load is connected.
2. Turn the fuel valve lever to the ON position.
3. Pull the choke knob to the CLOSED position. (with a cold and warm engine)
4. Make sure the auto-throttle switch is in the OFF position, or more time will be required for warm up.
5. Turn the engine switch to the ON position.
6. Pull the recoil starter grip slowly until the resistance is felt, then pull briskly.
7. Push the choke knob to the OPEN position as the engine warms up.
8. If you wish to use the auto-throttle system, turn the auto-throttle switch to the ON position after the engine has warmed up for 2 or 3 minutes.

# **STOPPING THE ENGINE**

---

## **STOPPING THE ENGINE**

### **In an emergency:**

1. To stop the engine in an emergency, turn the engine switch to the OFF position.

### **In normal use:**

1. Turn off the main switch of all the appliances connected to the generator.
2. Turn the AC circuit breaker to the OFF position.
3. Turn the engine switch to the OFF position.
4. Turn the fuel valve lever to the OFF position.

# MAINTENANCE

---

## THE IMPORTANCE OF MAINTENANCE

Good maintenance is essential for safe, economical, and trouble-free operation. It will also help reduce air pollution.

### **▲WARNING**

**Improper maintenance, or failure to correct a problem before operation, can cause a malfunction in which you can be seriously hurt or killed.**

**Always follow the inspection and maintenance recommendations and schedules in this owner's manual.**

To help you properly care for your generator, the following pages include a maintenance schedule, routine inspection procedures, and simple maintenance procedures using basic hand tools. Other service tasks that are more difficult, or require special tools, are best handled by professionals and are normally performed by a Honda technician or other qualified mechanic.

The maintenance schedule applies to normal operating conditions. If you operate your generator under severe conditions, such as sustained high-load or high-temperature operation, or use it in unusually wet or dusty conditions, consult your servicing dealer for recommendations applicable to your individual needs and use.

Remember that your servicing dealer knows your generator best and is fully equipped to maintain and repair it.

To ensure the best quality and reliability, use only new, genuine Honda parts or their equivalents for repair or replacement.

**Maintenance, replacement, or repair of the emission control devices and systems may be performed by any engine repair establishment or individual, using parts that are "certified" to EPA standards.**

---

## MAINTENANCE SAFETY

Some of the most important safety precautions follow. However, we cannot warn you of every conceivable hazard that can arise in performing maintenance. Only you can decide whether or not you should perform a given task.

### **▲ WARNING**

**Failure to properly follow maintenance instructions and precautions can cause you to be seriously hurt or killed.**

**Always follow the procedures and precautions in the owner's manual.**

### **Safety Precautions**

- Make sure the engine is off before you begin any maintenance or repairs. This will eliminate several potential hazards:
  - **Carbon monoxide poisoning from engine exhaust.**  
Be sure there is adequate ventilation whenever you operate the engine.
  - **Burns from hot parts.**  
Let the engine and exhaust system cool before touching.
  - **Injury from moving parts.**  
Do not run the engine unless instructed to do so.
- Read the instructions before you begin, and make sure you have the tools and skills required.
- To reduce the possibility of fire or explosion, be careful when working around gasoline. Use only a nonflammable solvent, not gasoline, to clean parts. Keep cigarettes, sparks, and flames away from all fuel-related parts.

---

## **EMISSION CONTROL SYSTEM INFORMATION**

### **Source of Emissions**

The combustion process produces carbon monoxide, oxides of nitrogen, and hydrocarbons. Control of hydrocarbons and oxides of nitrogen is very important because, under certain conditions, they react to form photochemical smog when subjected to sunlight. Carbon monoxide does not react in the same way, but it is toxic.

Honda utilizes lean carburetor settings and other systems to reduce the emissions of carbon monoxide, oxides of nitrogen, and hydrocarbons.

### **The U.S. and California Clean Air Acts**

EPA and California regulations require all manufacturers to furnish written instructions describing the operation and maintenance of emission control systems.

The following instructions and procedures must be followed in order to keep the emissions from your Honda engine within the emission standards.

### **Tampering and Altering**

Tampering with or altering the emission control system may increase emissions beyond the legal limit. Among those acts that constitute tampering are:

- Removal or alteration of any part of the intake, fuel, or exhaust systems.
- Altering or defeating the governor linkage or speed-adjusting mechanism to cause the engine to operate outside its design parameters.

---

## Problems That May Affect Emissions

If you are aware of any of the following symptoms, have your engine inspected and repaired by your servicing dealer.

- Hard starting or stalling after starting.
- Rough idle.
- Misfiring or backfiring under load.
- Afterburning (backfiring).
- Black exhaust smoke or high fuel consumption.

## Replacement Parts

The emission control systems on your Honda engine were designed, built, and certified to conform with EPA and California emission regulations. We recommend the use of genuine Honda parts whenever you have maintenance done. These original-design replacement parts are manufactured to the same standards as the original parts, so you can be confident of their performance. The use of replacement parts that are not of the original design and quality may impair the effectiveness of your emission control system.

A manufacturer of an aftermarket part assumes the responsibility that the part will not adversely affect emission performance. The manufacturer or rebuilder of the part must certify that use of the part will not result in a failure of the engine to comply with emission regulations.

## Maintenance

Follow the maintenance schedule on page 39. Remember that this schedule is based on the assumption that your machine will be used for its designed purpose. Sustained high-load or high-temperature operation, or use in unusually wet or dusty conditions, will require more frequent service.

---

## AIR INDEX

An Air Index Information hang tag/label is applied to engines certified to an emission durability time period in accordance with the requirements of the California Air Resources Board.

The bar graph is intended to provide you, our customer, the ability to compare the emissions performance of available engines. The lower the Air Index, the less pollution.

The durability description is intended to provide you with information relating to the engine's emission durability period. The descriptive term indicates the useful-life period for the engine's emission control system. See your *Emission Control Warranty* for additional information.

Descriptive Term	Applicable to Emissions Durability Period
Moderate	50 hours (0–65 cc) 125 hours (greater than 65 cc)
Intermediate	125 hours (0–65 cc) 250 hours (greater than 65 cc)
Extended	300 hours (0–65 cc) 500 hours (greater than 65 cc)

The Air Index Information hang tag must remain on the generator until it is sold. Remove the hang tag before operating the generator.

# MAINTENANCE SCHEDULE

REGULAR SERVICE PERIOD (3)		ITEM Perform at every indicated month or operating hour interval, whichever comes first.	Each use	First month or 20 Hrs.	Every 3 months or 50 Hrs.	Every 6 months or 100 Hrs.	Every year or 300 Hrs.	
●	Engine oil	Check level	○					
		Change		○		○		
●	Engine oil filter	Replace					Every 200 Hrs.	
●	Air filter	Check	○					
		Clean			○(1)			
		Replace					○ (* )	
	Battery electrolyte	Check level	○					
●	Spark plug	Check-adjust				○		
		Replace					○	
	Spark arrester	Clean				○		
	GFCI operation	Check	○					
●	Idle speed	Check-adjust					○(2)	
●	Valve clearance	Check-adjust					○(2)	
●	Combustion chamber	Clean					After every 500 Hrs. (2)	
●	Fuel tank	Clean		Every year (2)				
●	Fuel filter	Check				○		
		Replace					○(2)	
●	Fuel tube	Check		Every 2 years (Replace if necessary) (2)				

**NOTE:** ● Emission related items.

(\* )Replace the paper air filter only.

(1)Service more frequently when used in dusty areas.

(2)These items should be serviced by your servicing dealer, unless you have the proper tools and are mechanically proficient. Refer to the Honda shop manual for service procedures.

(3)For commercial use, log hours of operation to determine proper maintenance intervals.

---

## ENGINE OIL CHANGE

Drain the oil while the engine is warm to assure rapid and complete draining.

1. Open the top cover to access the oil filler cap.
2. Remove the oil filler cap and oil drain bolt, and drain the oil into a suitable container.
3. Retighten the oil drain bolt securely.
4. Refill to the upper limit mark on the dipstick with the recommended oil (see page 28). Tighten the oil filler cap securely.

### ENGINE OIL REFILL CAPACITIES:

Without oil filter replacement:  
approximately 1.16 US qt (1.10 ℓ , 0.97 Imp qt)

With oil filter replacement:  
approximately 1.48 US qt (1.40 ℓ , 1.23 Imp qt)

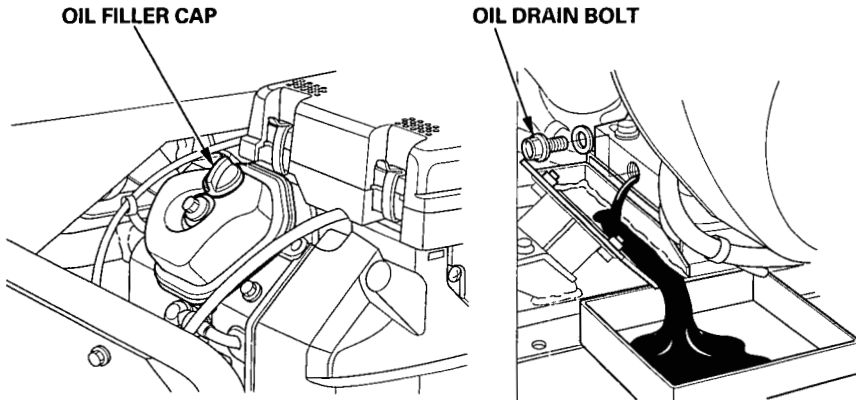

Wash your hands with soap and water after handling used oil.

Please dispose of used motor oil in a manner that is compatible with the environment. We suggest you take it in a sealed container to your local service station or recycling center for reclamation. Do not throw it in the trash, pour it on the ground, or down a drain.

---

## OIL FILTER CHANGE

1. Drain the engine oil, and retighten the drain bolt securely (see page 42).
2. Remove the front cover to access the oil filter.
3. Remove the oil filter, and drain the oil into a suitable container. Discard the used oil filter.
4. Clean the filter mounting base, and coat the O-ring of the new oil filter with clean engine oil.

### NOTICE

**Use only a Honda genuine oil filter or a filter of equivalent quality specified for your model. Using the wrong Honda filter or a non-Honda filter which is not of equivalent quality may cause engine damage.**

5. Screw on the new oil filter by hand, until the O-ring contacts the filter mounting base, then use an oil filter socket tool to tighten the filter an additional 7/8 turn.

**TORQUE:** 16 lbf-ft (22 N·m , 2.2 kgf·m)

6. Refill the crankcase with the specified amount of the recommended oil (see page 28 & 42 ). Reinstall the oil filler cap/dipstick.
7. Start the engine and check for oil filter leaks.
8. Stop the engine, and check the oil level as described on page 28. If necessary, add oil to the upper limit mark on the dipstick.

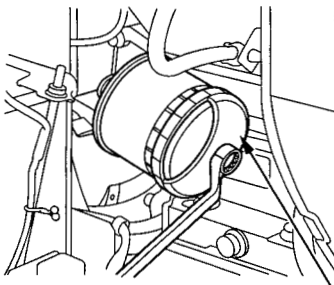

OIL FILTER SOCKET TOOL

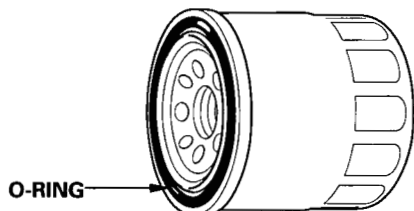

---

## AIR CLEANER SERVICE

A dirty air filter will restrict air flow to the carburetor. To prevent carburetor malfunction, service the air cleaner regularly. Service more frequently when operating the generator in extremely dusty areas.

**NOTICE**

**Never run the generator without the air filter. Rapid engine wear will result.**

1. Open the top cover to access the air cleaner.
2. Release four latch tabs from the air cleaner cover, and remove the cover.
3. Remove the foam air filter from the cover.
4. Remove the paper air filter from the air cleaner case.

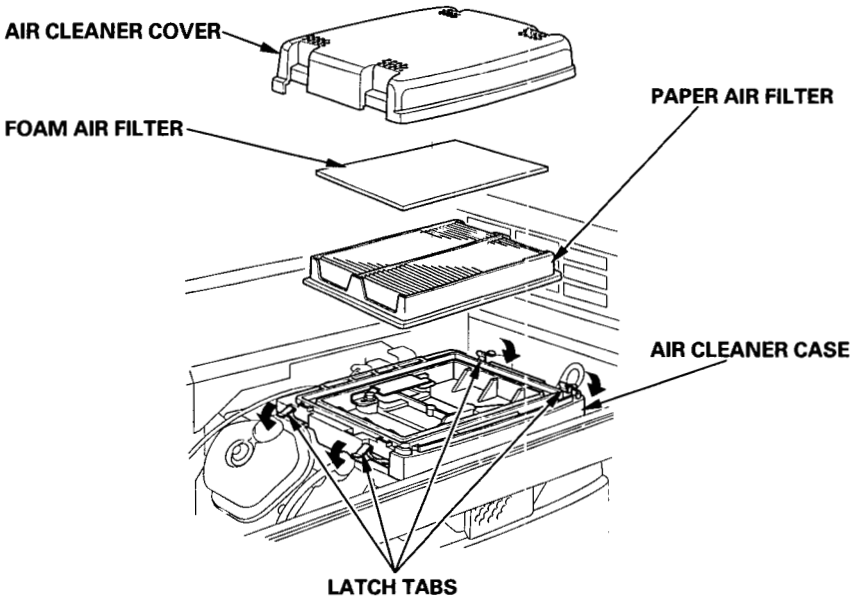

---

5. Inspect both air filters, and replace them if they are damaged. Always replace the paper air filter at the scheduled interval (see page 41 ).

6. Clean the air filters if they are to be reused.

Paper air filter: Tap the paper air filter several times on a hard surface to remove dirt, or blow compressed air [not exceeding 30 psi (207 kPa, 2.1 kgf/cm<sup>2</sup>)] through the paper air filter from the air cleaner case side.

Never try to brush off dirt: brushing will force dirt into the fibers. Replace the paper air filter if it is excessively dirty.

Foam air filter : Clean in warm soapy water, rinse, and allow to dry thoroughly. Or clean in nonflammable solvent, not gasoline, and allow to dry. Do not put oil to the foam air filter.

7. Wipe dirt from the inside of the air cleaner case and cover, using a moist rag. Be careful to prevent dirt from entering the air chamber that leads to the carburetor.

8. Place the foam air filter to the air cleaner cover, then reinstall the paper air filter and cover to the air cleaner case. Hook four latch tabs securely.

---

## SPARK PLUG SERVICE

In order to service the spark plug, you will need a spark plug wrench (commercially available).

**Recommended spark plugs:** ZGR5A (NGK)  
J16CR-U (DENSO)

To ensure proper engine operation, the spark plugs must be properly gapped and free of deposits.

If the engine has been running, the exhaust pipe and muffler will be very hot. Be careful not to touch the exhaust pipe or muffler.

1. Remove the spark plug caps.
2. Clean any dirt from around the spark plug bases.
3. Use a spark plug wrench to remove the spark plugs.

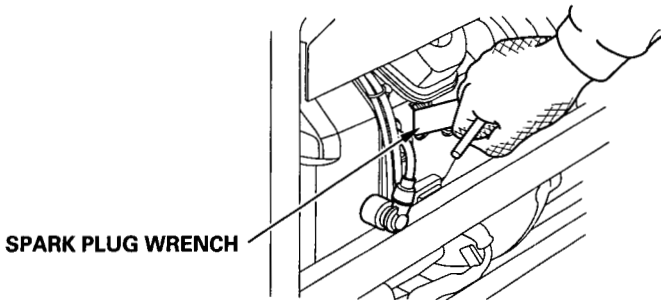

4. Visually inspect the spark plugs. Discard them if the insulator is cracked or chipped. Clean the spark plugs with a wire brush if they are to be reused.
5. Measure the plug gap with a feeler gauge. Correct as necessary by carefully bending the side electrode.

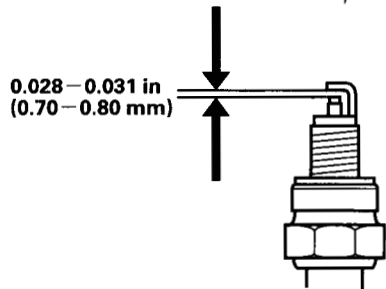

**The gap should be:**  
0.028—0.031 in (0.70—0.80 mm)

- 
6. Check that the spark plug washers are in good condition, and thread the spark plugs in by hand to prevent cross-threading.
  7. After the spark plugs are seated, tighten with a spark plug wrench to compress the washer.

If installing a new spark plug, tighten 1/2 turn after the spark plug seats to compress the washer. If reinstalling a used spark plug, tighten 1/8–1/4 turn after the spark plug seats to compress the washer.

**NOTICE**

**The spark plug must be securely tightened. An improperly tightened spark plug can become very hot and could damage the engine. Never use spark plugs which have an improper heat range. Use only the recommended spark plugs or equivalent.**

8. Reinstall the spark plug caps on the spark plugs securely.

---

## SPARK ARRESTER MAINTENANCE

If the generator has been running, the muffler will be very hot. Allow it to cool before proceeding.

The spark arrester must be serviced every 100 hours to maintain its efficiency.

1. Remove the special screw, and remove the spark arrester from the muffler.

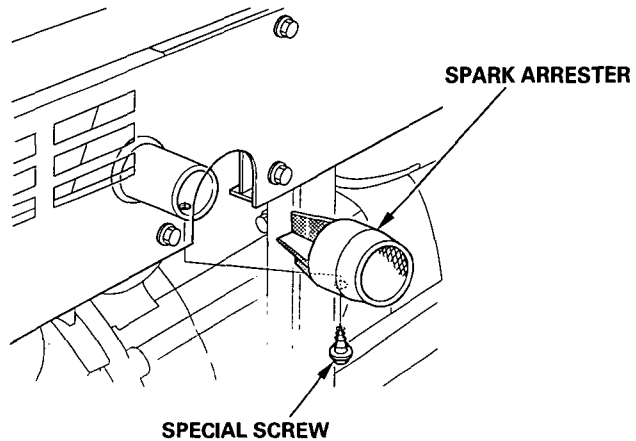

2. Use a brush to remove carbon deposits from the spark arrester screen.



3. Inspect the screen for breaks or tears and replace it if necessary.
4. Install the spark arrester in the reverse order of removal.

---

## FUEL SEDIMENT CUP CLEANING

The sediment cup prevents dirt or water which may be in the fuel tank from entering the carburetor. If the engine has not been run for a long time, the sediment cup should be cleaned.

1. Turn the engine switch to the OFF position.
2. Turn the fuel valve lever to the OFF position.
3. Remove the sediment cup by turning it counterclockwise.
4. Clean the sediment cup and O-ring in nonflammable or high flash point solvent.
5. Reinstall the O-ring, and sediment cup.
6. Turn the fuel valve ON and check for leaks.

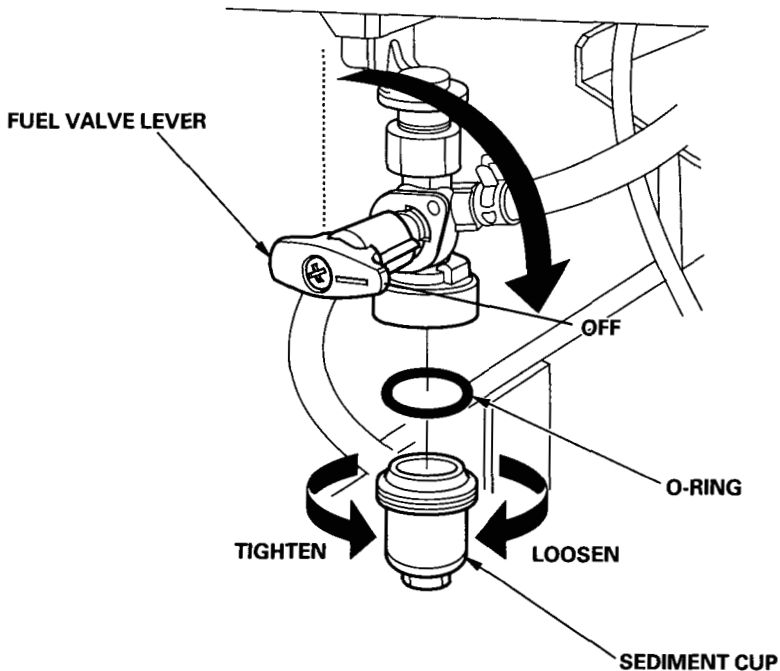

---

## FUEL FILTER

1. Check the fuel filter for water accumulation or sediment.

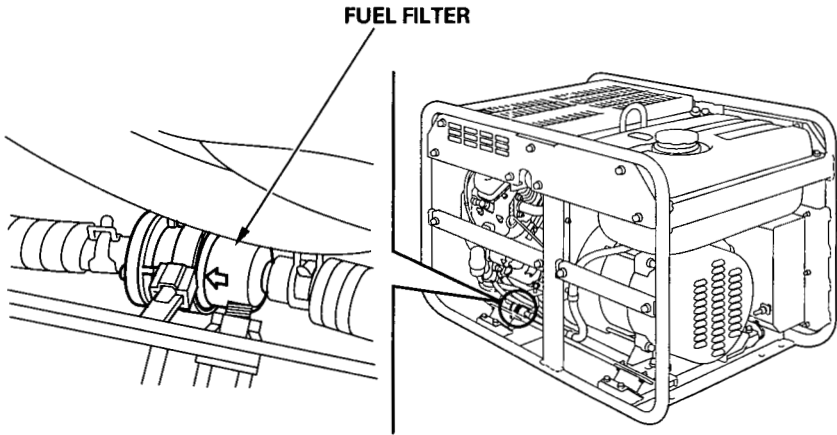

2. If the fuel filter is found with excessive water accumulation or sediment, take the generator to your servicing dealer.

---

## FUSE REPLACEMENT

Turn the engine switch OFF and remove the key before checking or replacing fuses to prevent accidental short-circuiting.

Remove the fuse holder cover and replace the fuse. Use only fuses with rating that specified.

**MAIN FUSE:** 10A

**SUB FUSE:** 5A

### NOTICE

- If frequent fuse failure occurs, determine the cause and correct the problem before attempting to operate the generator further.
- Never use a fuse with a different rating from that specified. Serious damage to the electrical system or a fire may result.

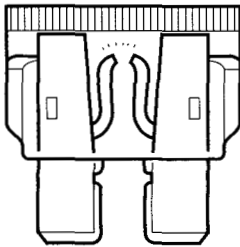
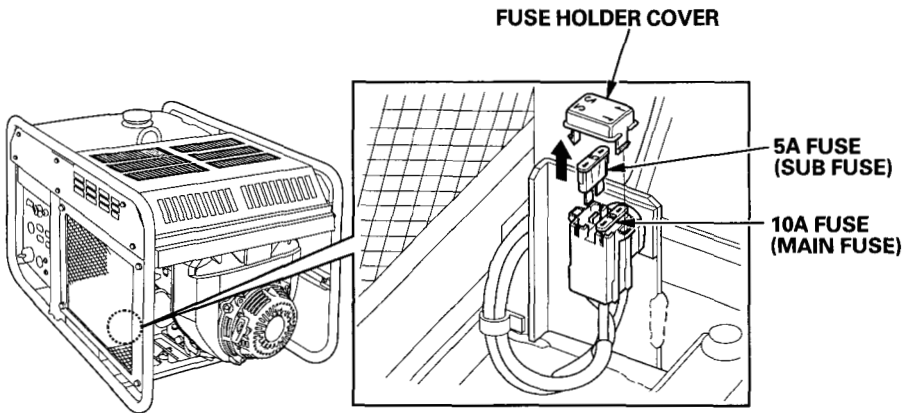

**BLOWN FUSE**

---

## **BATTERY**

**The battery contains sulfuric acid (electrolyte) which is highly corrosive and poisonous.**

**Getting electrolyte in your eyes or on your skin can cause serious burns.**

**Wear protective clothing and eye protection when working near the battery.**

### **EMERGENCY PROCEDURES:**

**Eyes**— Flush with water from a cup or other container for at least 15 minutes (water under pressure can damage the eye). Immediately call a physician, local poison control, or 911.

**Skin**— Remove contaminated clothing. Flush the skin with large quantities of water. Call a physician immediately.

**Swallowing**— Drink water or milk. Call your local poison control center or a physician immediately.

**WARNING:** Battery posts, terminals and related accessories contain lead and lead compounds. **Wash hands after handling.**

## Removal

1. Remove the front cover to access the battery.

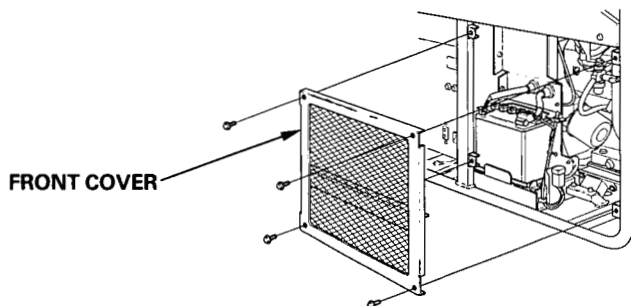

2. Remove the negative (-) cable from the battery negative (-) terminal; then remove the positive (+) cable from the battery positive (+) terminal.

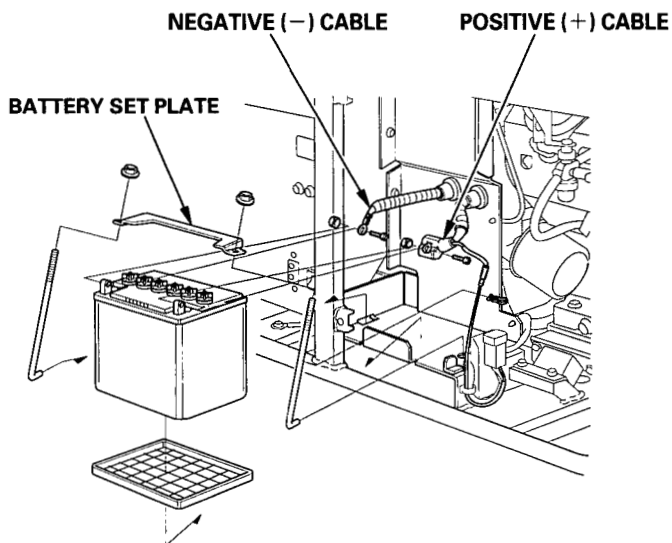

3. Remove the battery set plate.
4. Remove the battery from the battery tray.

## Installation

1. Install the battery tray in the generator, and the battery on the tray.
2. Make sure the battery is on the edge of the battery tray of the fuse holder side. Install the battery set plate.
3. Install the positive (+) cable to the battery positive (+) terminal, make sure to cover the terminal with the terminal cover. Then install the negative (-) cable to the battery negative (-) terminal.

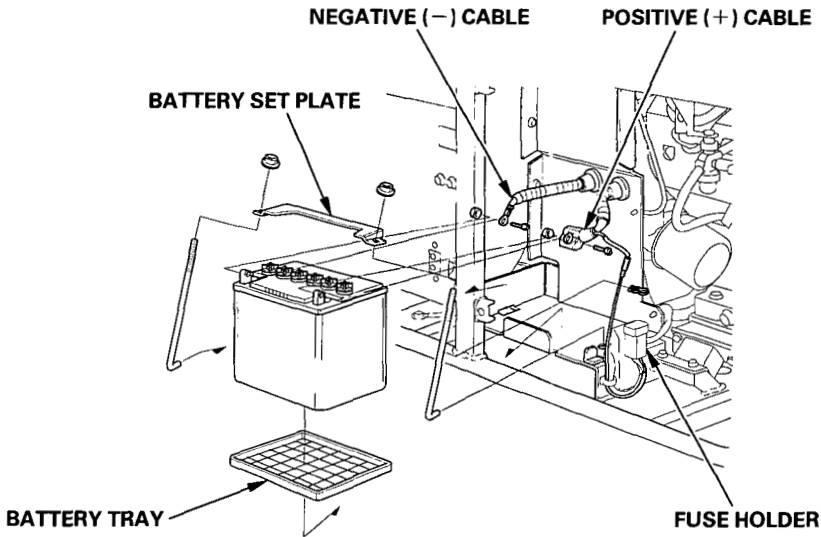

4. Install the front cover. Be sure to install the cover in the direction shown below.

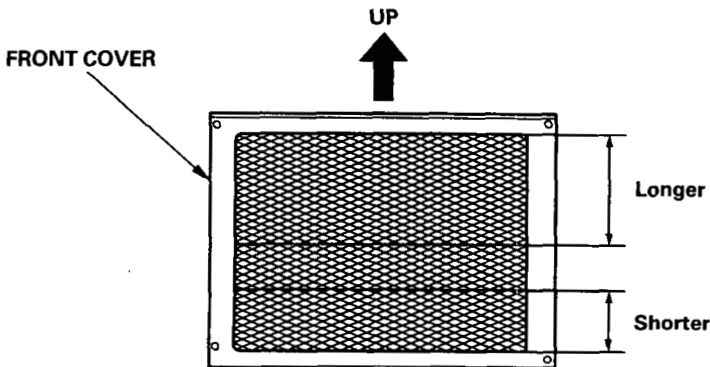

---

## Refilling Battery Fluid

If the generator is operated with insufficient battery electrolyte, sulfation and battery plate damage will occur.

If rapid loss of electrolyte is experienced, or if your battery seems to be weak, causing slow starting or other electrical problems, see your authorized Honda generator dealer.

1. Remove the front cover and the battery (see pages 52 – 53 ).
2. Check the electrolyte level in each battery cell.
3. Remove the battery filler caps and carefully add distilled water to the upper level line. Never overfill the battery.
4. Install the battery filler caps.
5. Install the battery and the front cover (see page 52 & 54 ).

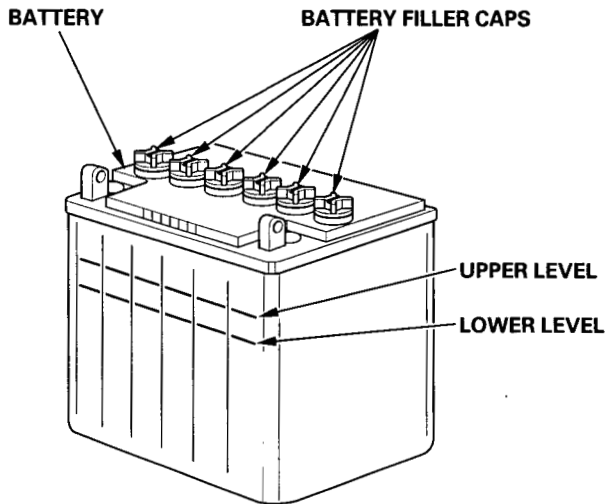

---

## Charging

The generator's engine has an approximate 3-amp charging system to charge the battery while the engine is running. If the generator is only used periodically, the battery must be charged monthly to maintain the battery service life.

A lead acid battery self discharges at a rate of 0.5–1.0% per day. This means that the battery, if the generator is not operated in a month, can discharge as much as 30% in the same period. This could cause the engine not to crank or shorten the service life of the battery. To charge the battery, follow the procedures below.

The battery is rated at 24AH (ampere-hours)/5 HR. 10% of the ampere-hour rating should be used as the charging current. A battery charger should be used that can be adjusted to deliver 2.4 amps.

### **▲WARNING**

**The battery gives off explosive gasses; keep sparks, flames and cigarettes away from the battery while charging. Provide adequate ventilation when charging.**

1. Remove the front cover and the battery (see pages 52–53 ).
2. Remove the battery cell caps.
3. Connect the battery charger following the manufacturer's instructions.
4. Charge the battery 3–4 hours.
5. After the battery is charged, inspect the electrolyte level in each of the cells. Add distilled water as necessary (see page 55 ).
6. Install the battery cell caps.
7. Clean the outside of the battery and the battery tray with a solution of baking soda and water.
8. Install the battery and the front cover (see page 52 & 54 ).

## TRANSPORTING

If the generator has been used, allow it cool for at least 15 minutes before loading the generator on the transport vehicle. A hot engine and exhaust system can burn you and can ignite some material.

When transporting the generator, turn the engine switch and the fuel valve OFF, and keep the generator level to reduce the possibility of fuel leakage.

Take care not to drop or strike the generator when transporting. Do not place heavy objects on the generator.

## STORAGE

Before storing the unit for an extended period:

1. Be sure the storage area is free of excessive humidity and dust.
2. Service according to the table below:

<b>STORAGE TIME</b>	<b>RECOMMENDED SERVICE PROCEDURE TO PREVENT HARD STARTING</b>
Less than 1 month	No preparation required
1 to 2 months	Fill with fresh gasoline and add gasoline conditioner *.
2 months to 1 year	Fill with fresh gasoline and add gasoline conditioner *. Drain the carburetor float bowl. (page 59 ). Drain the fuel sediment cup. (page 49 ).
1 year or more	Fill with fresh gasoline and add gasoline conditioner *. Drain the carburetor float bowl. (page 59 ). Drain the fuel sediment cup. (page 49 ). Remove the spark plugs. Pour a tablespoon (5–10 cc) of clean engine oil into each cylinder. Using the electric starter, crank the engine a few revolutions to distribute the oil in the cylinders. Reinstall the spark plugs. Change the engine oil. (page 42 ). After removal from storage, drain the stored gasoline into a suitable container, and fill with fresh gasoline before starting.
* Use gasoline conditioners that are formulated to extend storage life. Contact your authorized Honda generator dealer for conditioner recommendations.	

---

## Storage Procedure

### 1. Drain the fuel.

- a. Remove the fuel tank cap, and empty the fuel tank into an approved gasoline container using a commercially available hand siphon. Reinstall the fuel tank cap.

#### **⚠ WARNING**

**Gasoline is highly flammable and explosive. You can be burned or seriously injured when handling fuel.**

- **Stop the engine and keep heat, sparks, and flame away.**
- **Handle fuel only outdoors.**
- **Wipe up spills immediately.**

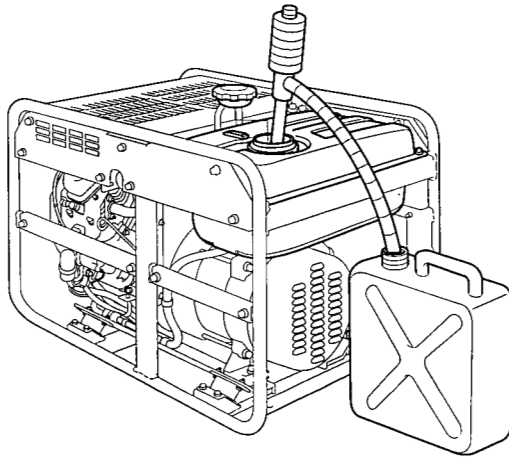

- 
- b. Pull out the carburetor drain tube end under the fan cover of the engine, and place a suitable container.
  - c. Loosen the carburetor drain screw.
  - d. Drain the gasoline from the carburetor into the container.
  - e. Tighten the carburetor drain screw securely.

**CARBURETOR DRAIN SCREW**

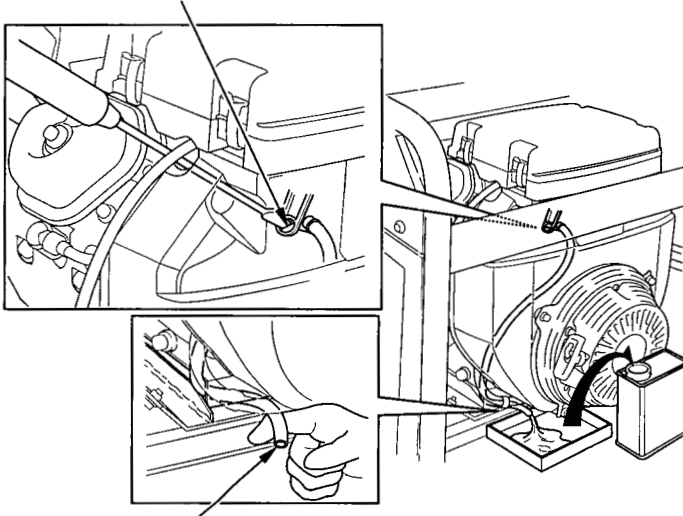

**CARBURETOR DRAIN TUBE**

2. Change the engine oil (page 42 ).
3. Remove the two spark plugs and pour about a tablespoon of clean engine oil into the cylinders. Crank the engine several revolutions to distribute the oil, then reinstall the spark plugs.
4. Remove the battery and store it in a cool, dry place. Recharge it once a month.
5. Cover the engine to keep out dust.

When the engine will not start:

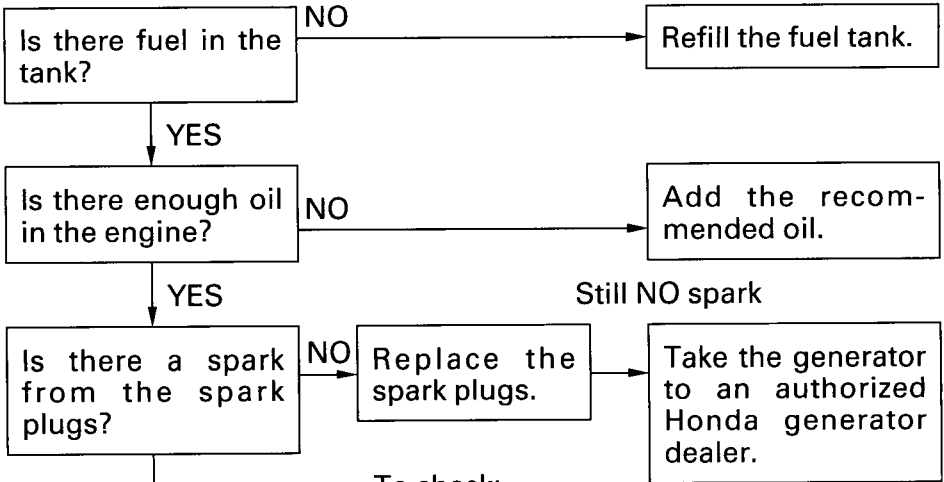

**▲WARNING**

Be sure there is no spilled fuel around the spark plugs. Spilled fuel may ignite.

To check:

- 1) Remove the spark plug cap and clean any dirt from around the spark plug.
- 2) Remove the spark plug and install the spark plug in the plug cap.
- 3) Set the plug side electrode on the cylinder head bolt.
- 4) Crank the engine, sparks should jump across the gap.

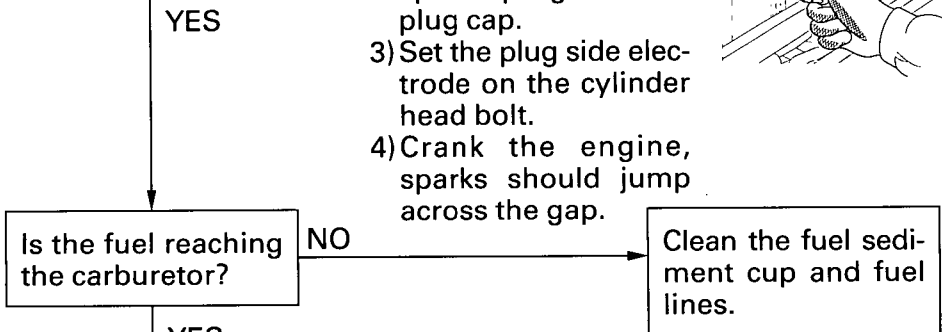
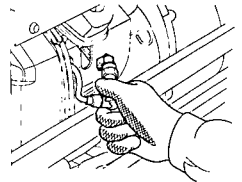

To check:

- 1) Turn off the engine switch and loosen the drain screw.
- 2) Fuel should flow from the drain when the engine switch is turned on.

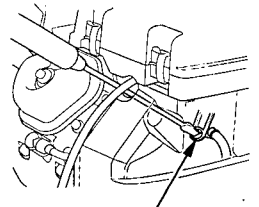

DRAIN SCREW

No electricity at the AC receptacles:

〈When the GFCI RESET button is extended〉

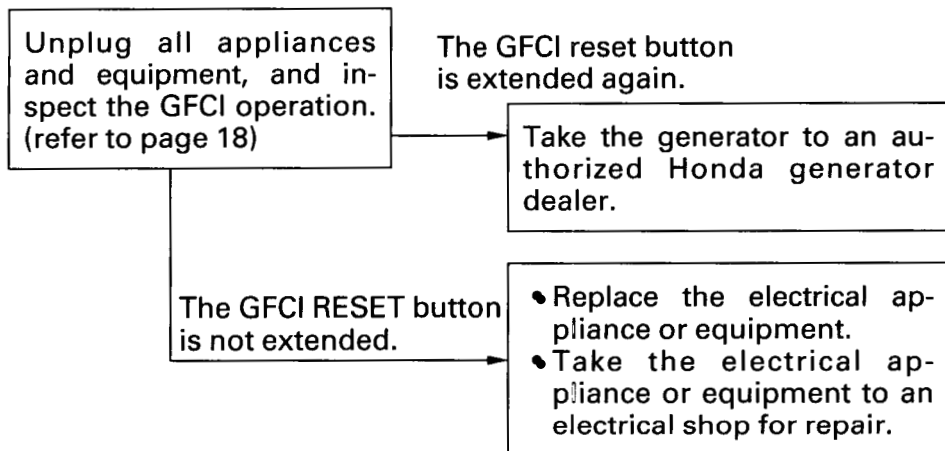

〈When the GFCI RESET button is not extended〉

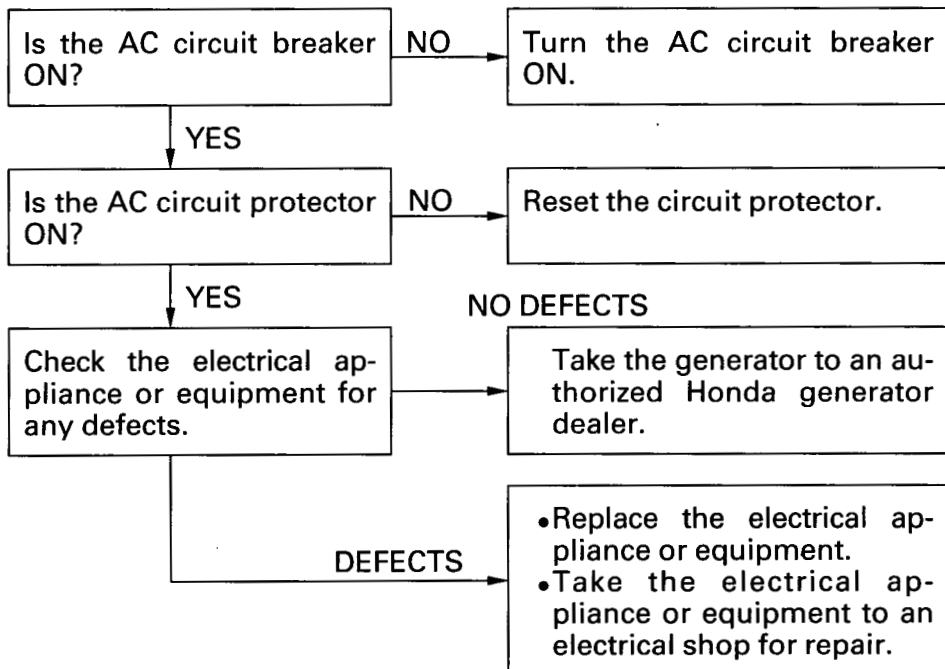



# SPECIFICATIONS

## Dimensions

Model (Type)	EB11000K1
Length	37.4 in (950 mm)
Width	24.2 in (615 mm)
Height	24.4 in (620 mm)
Dry weight	434 lbs (197 kg)

## Engine

Model	GX620K1
Engine Type	4-Stroke, O.H.V. 2 cylinder
Displacement [Bore x Stroke]	37.5 cu-in (614 cm <sup>3</sup> ) 3.03 × 2.60 in (77 × 66 mm)
Engine Speed	3,600 rpm
Cooling System	Forced air
Ignition System	Transistorized magneto
Engine Oil Refill Capacities	approximately 1.16 US qt (1.10 ℓ , 0.97 Imp qt) without oil filter replacement approximately 1.48 US qt (1.40 ℓ , 1.23 Imp qt) with oil filter replacement
Fuel Tank Capacity	6.9 US gal (26 ℓ , 5.7 Imp gal)
Spark Plug	ZGR5A (NGK) / J16CR-U (DENSO)

## Generator

Model	EB11000K1	
Type	2-pole, rotating field type	
AC output	Rated voltage	120 V/240 V
	Rated frequency	60 Hz
	Rated Ampere	39.6 A × 2/39.6 A
	Rated Output	※ 9.5 kVA
	Maximum Output	※ 10.5 kVA

## Tune-up

ITEM	SPECIFICATION	MAINTENANCE
Spark plug gap	0.028 – 0.031 in (0.70 – 0.80 mm)	Refer to page: 46
Valve clearance	IN: 0.15 ± 0.02 mm (cold) EX: 0.20 ± 0.02 mm (cold)	See your authorized Honda dealer
Other specifications	No other adjustments needed.	

※The AC output when ambient temperature is 68°F (20°C).

Specifications are subject to change without notice.

# WARRANTY SERVICE INFORMATION

---

Servicing dealership personnel are trained professionals. They should be able to answer any question you may have. If you encounter a problem that your dealer does not solve to your satisfaction, please discuss it with the dealership's management. The Service Manager or General Manager can help. Almost all problems are solved in this way.

If you are dissatisfied with the decision made by the dealership's management, contact the Honda Power Equipment Customer Relations Office. You can write to:

American Honda Motor Co., Inc.  
Power Equipment Division  
Customer Relations Office  
4900 Marconi Drive  
Alpharetta, Georgia 30005-8847

Or telephone: (770) 497-6400

When you write or call, please give us this information:

- Model and serial number (see page 10 )
- Name of dealer who sold the generator to you
- Name and address of dealer who services your generator
- Date of purchase
- Your name, address, and telephone number
- A detailed description of the problem

# INDEX

---

COMPONENT IDENTIFICATION .....	9
CONTENTS .....	3
CONTROLS .....	12
Auto-throttle Switch .....	20
Choke Knob .....	13
Circuit Breaker .....	14
Circuit Protector .....	15
Engine Switch .....	12
Fuel Valve .....	13
Ground Fault Circuit Interrupter (GFCI) .....	16
Ground Terminal .....	21
Hour Meter .....	20
Oil Alert® System .....	21
Recoil Starter .....	12
GENERATOR USE .....	22
AC Applications .....	23
AC Operation .....	24
AC Receptacle Selection .....	25
Auto-throttle System .....	26
Connections to a Building Electrical System .....	22
Ground System .....	22
High Altitude Operation .....	27
Special Requirements .....	22
MAINTENANCE .....	36
Air Cleaner Service .....	44
Air Index .....	40
Battery .....	52
Emission Control System Information .....	38
Engine Oil Change .....	42
Fuel Filter .....	50
Fuel Sediment Cup Cleaning .....	49
Fuse Replacement .....	51
Importance of Maintenance .....	36
Maintenance Safety .....	37
Maintenance Schedule .....	41
Oil Filter Change .....	43
Spark Arrester Maintenance .....	48
Spark Plug Service .....	46
PRE-OPERATION CHECK .....	28
Battery .....	32
Engine Oil .....	28
Fuel Recommendations .....	30
Refueling .....	29

---

SAFETY .....	5
Safety Information .....	7
Safety Label Locations .....	5
SPECIFICATIONS .....	64
STARTING THE ENGINE .....	33
STOPPING THE ENGINE .....	35
TRANSPORTING/STORAGE .....	57
TROUBLESHOOTING .....	61
WARRANTY SERVICE INFORMATION .....	65
WIRING DIAGRAM .....	63

---

**MEMO**

# HONDA

The Power of Dreams

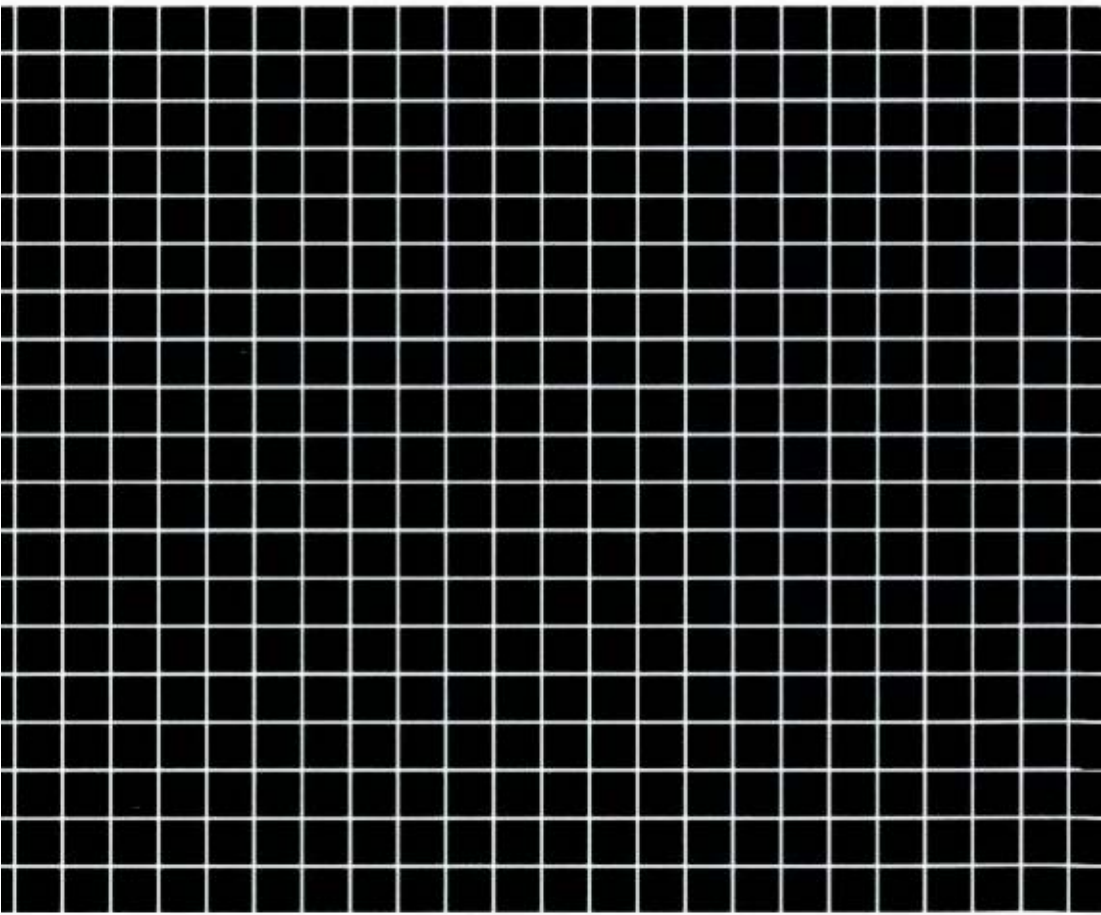

31Z08601  
00X31-Z08-6010

**EM3** K1  
AH HI HC 300.2001.04  
Printed in Japan