

**HONDA**

**Power**

**Equipment**

# Owner's Manual

## Rotary Mower

### HRB217TDA



**HONDA**

***Harmony***<sup>®</sup>



## **WARNING:**



The engine exhaust from this product contains chemicals known to the State of California to cause cancer, birth defects or other reproductive harm.

Keep this owner's manual handy, so you can refer to it at any time. This owner's manual is considered a permanent part of the lawn mower and should remain with the lawn mower if resold.

The information and specifications included in this publication were in effect at the time of approval for printing. American Honda Motor Co., Inc. reserves the right, however, to discontinue or change specifications or design at any time without notice and without incurring any obligation whatever. No part of this publication may be reproduced without written permission.

# INTRODUCTION

Congratulations on your selection of a Honda lawn mower! We are certain you will be pleased with your purchase of one of the finest lawn mowers on the market.

We want to help you get the best results from your new mower and to operate it safely. This manual contains the information on how to do that; please read it carefully.

As you read this manual, you will find information preceded by a **NOTICE** symbol. That information is intended to help you avoid damage to your mower, other property, or the environment.

We suggest you read the *Distributor's Limited Warranty* (page 66) and *Emission Control System Warranty* (page 67) to fully understand coverage and your responsibilities of ownership.

When your mower needs scheduled maintenance, keep in mind that an authorized Honda servicing dealer is specially trained in servicing Honda mowers and is supported by the parts and service divisions of American Honda. Your Honda dealer is dedicated to your satisfaction and will be pleased to answer your questions and concerns.

Best Wishes,  
Power Equipment Division  
American Honda Motor Co., Inc.

# INTRODUCTION

---

## A FEW WORDS ABOUT SAFETY

Your safety, and the safety of others, is very important. And using this lawn mower safely is an important responsibility.

To help you make informed decisions about safety, we have provided operating procedures and other information on labels and in this manual. This information alerts you to potential hazards that could hurt you or others.

Of course, it is not practical or possible to warn you about all the hazards associated with operating or maintaining a lawn mower. You must use your own good judgment.

You will find important safety information in a variety of forms including:

- **Safety Labels** — on the lawn mower.
- **Safety Messages** — preceded by a safety alert  symbol and one of three signal words: DANGER, WARNING, or CAUTION.

These signal words mean:

 **DANGER** You WILL be KILLED or SERIOUSLY HURT if you don't follow instructions.

 **WARNING** You CAN be KILLED or SERIOUSLY HURT if you don't follow instructions.

 **CAUTION** You CAN be HURT if you don't follow instructions.

- **Safety Headings** — such as *IMPORTANT SAFETY REMINDERS* or *IMPORTANT SAFETY PRECAUTIONS*.
- **Safety Chapter** — such as *LAWN MOWER SAFETY*.
- **Instructions** — how to use this mower correctly and safely. This entire book is filled with important safety information — please read it carefully.

# CONTENTS

<b>LAWN MOWER SAFETY</b> .....	<b>4</b>
IMPORTANT SAFETY INFORMATION .....	4
IMPORTANT MESSAGE TO PARENTS .....	5
SAFETY LABEL LOCATIONS .....	6
<b>CONTROLS &amp; FEATURES</b> .....	<b>7</b>
COMPONENT & CONTROL LOCATIONS .....	7
<b>BEFORE OPERATION</b> .....	<b>11</b>
ARE YOU READY TO GET STARTED? .....	11
IS YOUR LAWN MOWER READY TO GO? .....	11
CHECK YOUR WORK AREA .....	12
GET THE MOWER READY .....	13
<b>OPERATION</b> .....	<b>16</b>
MOWING PRECAUTIONS .....	16
STARTING THE ENGINE .....	16
OPERATING THE CONTROLS FOR MOWING .....	18
STOPPING THE ENGINE .....	20
SAFE MOWING PRACTICES .....	21
MOWING TIPS .....	23
<b>SERVICING YOUR LAWN MOWER</b> .....	<b>26</b>
THE IMPORTANCE OF MAINTENANCE .....	26
MAINTENANCE SAFETY .....	27
MAINTENANCE SCHEDULE .....	28
BLADES .....	29
GRASS BAG CLEANING AND REPLACEMENT .....	32
ENGINE MAINTENANCE .....	33
CONTROL CABLE ADJUSTMENTS .....	39
THROTTLE CABLE INSPECTION .....	42
FUEL SYSTEM .....	43
<b>STORAGE</b> .....	<b>45</b>
STORAGE PREPARATION .....	45
PLACING IN STORAGE .....	50
REMOVING FROM STORAGE .....	50
<b>TRANSPORTING</b> .....	<b>51</b>
BEFORE LOADING .....	51
LOADING AND UNLOADING .....	51
<b>TAKING CARE OF UNEXPECTED PROBLEMS</b> .....	<b>52</b>
ENGINE PROBLEMS .....	52
VIBRATION PROBLEMS .....	53
MOWING AND BAGGING PROBLEMS .....	53
<b>SET-UP</b> .....	<b>54</b>
BEFORE OPERATION .....	55
<b>TECHNICAL &amp; CONSUMER INFORMATION</b> .....	<b>56</b>
TECHNICAL INFORMATION .....	56
EMISSION CONTROL SYSTEM .....	59
SPECIFICATIONS .....	62
CONSUMER INFORMATION .....	64
<b>INDEX</b> .....	<b>71</b>
<b>QUICK REFERENCE INFORMATION</b> .....	<b>inside back cover</b>

# LAWN MOWER SAFETY

## IMPORTANT SAFETY INFORMATION

Most accidents with walk-behind mowers can be prevented if you follow all instructions in this manual and on the mower. The most common hazards, according to accident statistics, are discussed below, along with the best way to protect yourself and others.

### **Avoid Rotating Blades**

Rotating blades can cause serious cuts and even amputate fingers, hands, toes, or feet. Keep away from the mower deck whenever the engine is running. If you need to adjust the cutting height, or work around the deck for any other reason, always shut off the engine. Wear heavy gloves and disconnect the spark plug cap when you need to clean the mower deck or handle the blades.

### **Clear Mowing Area**

Mower blades can throw rocks and other objects with enough force to cause serious injury. Before mowing, carefully inspect the area and remove all sticks, stones, pieces of wire, and other loose objects. Never operate the blades over gravel.

### **Keep Shields in Place**

Guards and shields are designed to protect you from being hit by thrown objects and from hot engine parts and moving components. For your safety and the safety of others, keep all shields in place when the engine is running.

### **Refuel with Care**

Gasoline is extremely flammable and gasoline vapor can explode. Refuel only outdoors, in a well-ventilated area, with the engine OFF. Never smoke near gasoline, and keep other flames and sparks away. Always store gasoline in an approved container.

### **Wear Protective Clothing**

Wearing protective clothing will reduce your risk of injury. Long pants and eye protection reduce the risk of injuries from thrown objects. Sturdy shoes with aggressive soles will help protect your feet and give you better traction on slopes or uneven ground.

### **Turn Engine Off When Not Mowing**

If you need to leave the mower for any reason, even just to inspect the lawn ahead, always turn the engine OFF.

## IMPORTANT MESSAGE TO PARENTS

YOUR CHILDREN'S SAFETY IS VERY IMPORTANT to Honda. That's why we urge you to read this message before letting your youngster operate this lawn mower. Lawn mowers are tools, not toys. As with any equipment, bad judgments can result in serious injuries. You can help prevent accidents by making good decisions about if, when, and how your youngster operates this equipment.

The first question you'll need to ask is whether your youngster is capable of operating this mower safely. Remember, young people vary widely, and **AGE IS NOT THE ONLY FACTOR**.

Physically, a youngster must be **LARGE ENOUGH AND STRONG ENOUGH** to easily start the mower and control its direction. The youngster also needs enough size, strength, and coordination to comfortably reach and operate the controls.

Another, tougher question you need to ask is if your youngster has enough **MATURITY AND RESPONSIBILITY** to safely operate this mower. Does the young person think through problems and come to logical solutions? Be honest! Anyone who takes unnecessary risks and doesn't obey rules should not operate this lawn mower.

If you decide that your son or daughter can handle the mower safely, **CAREFULLY READ THE OWNER'S MANUAL** with your youngster. Make sure you both understand all instructions and safety information. Also, be sure your youngster wears sturdy shoes and other protective clothing when operating or handling the mower.

**SUPERVISION** is also very important. Walk with your youngster during the first few minutes of mowing. Even after the youngster has become confident with the mower, do not let the young person use the mower without good adult supervision. An adult should also be present during refueling and maintenance. In fact, it's up to parents to make sure that the mower is properly maintained and kept in safe operating condition.

By always placing safety first, your youngster will acquire useful skills and a sense of accomplishment. And you'll both get the best results from your lawn mower.

# LAWN MOWER SAFETY

## SAFETY LABEL LOCATIONS

These labels warn you of potential hazards that can cause serious injury. Read them carefully. If a label comes off or becomes hard to read, contact an authorized Honda servicing dealer for a replacement.

### ⚠ CAUTION

UNDER NORMAL USAGE, THIS BAG MATERIAL IS SUBJECT TO DETERIORATION AND WEAR, AND SHOULD BE CHECKED FREQUENTLY FOR BAG REPLACEMENT. THIS BAG CONFORMS TO A.N.S.I. STANDARD B71.1, ANY REPLACEMENT MUST MEET THIS STANDARD.

### ⚠ WARNING

Objects thrown by blade can cause serious injury.

- Inspect area and remove debris before mowing.
- Keep children and others away.
- Wear eye protection.
- Follow all instructions in your Owner's Manual.

**DO NOT OPERATE UNLESS GUARD IS CLOSED OR BAG IS IN PLACE**

### ⚠ DANGER

KEEP HANDS and FEET AWAY



### ⚠ CAUTION

**HOT MUFFLER CAN BURN YOU.**  
Stay away if engine has been running.

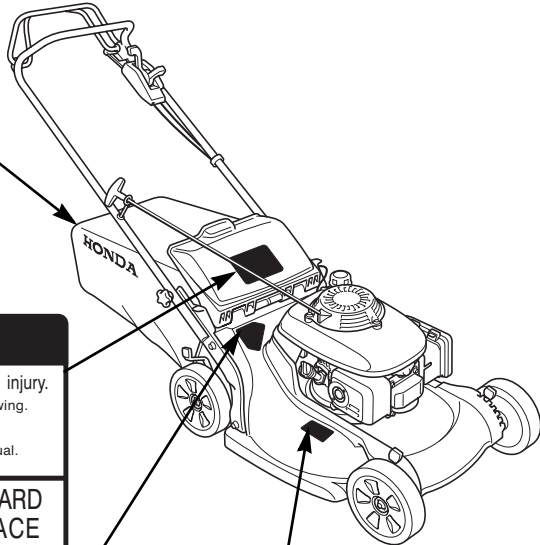



# CONTROLS & FEATURES

## COMPONENT & CONTROL LOCATIONS

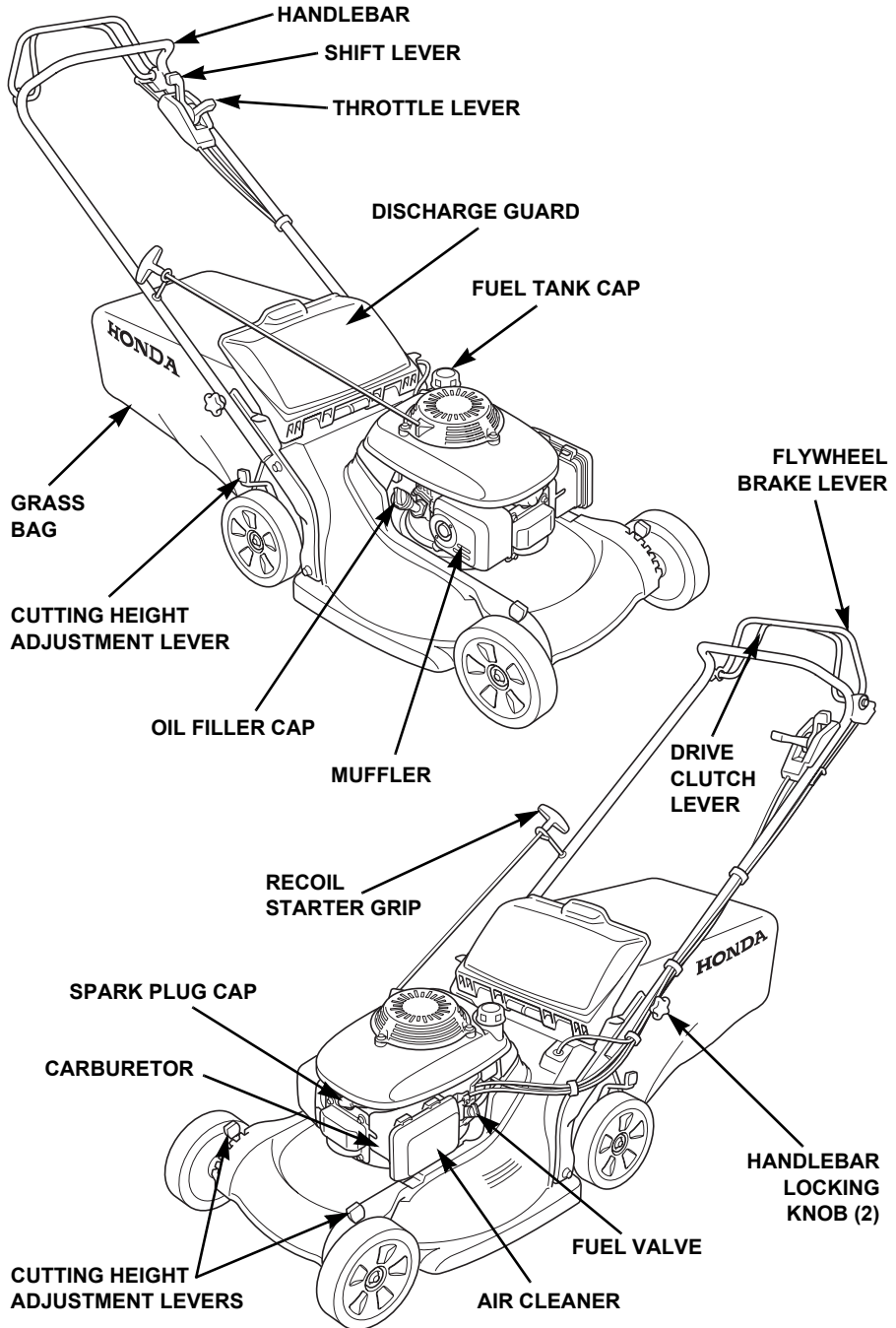

# CONTROLS & FEATURES

---

## Fuel Valve

The fuel valve opens and closes the fuel passage from the fuel tank to the carburetor.

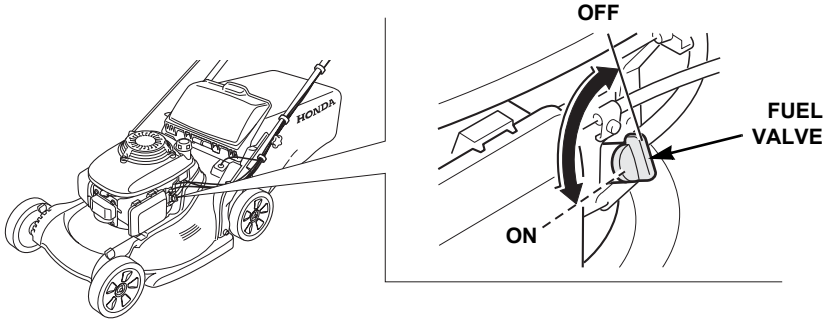

## Throttle Lever

The throttle lever controls engine speed and opens and closes the choke.

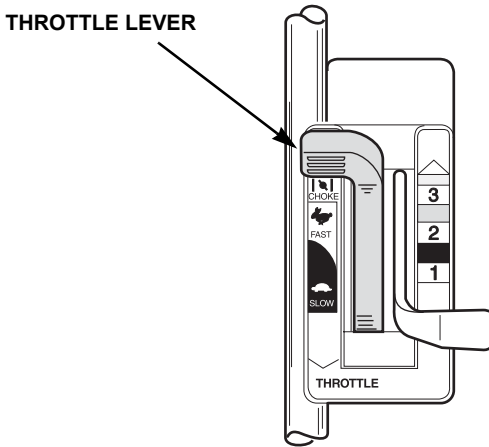

**CHOKE** Closes the choke; use when starting a cold engine.



**FAST** For restarting a warm engine and for mowing.



**SLOW** For idling the engine.

## Flywheel Brake Lever

This lever is connected to the engine flywheel brake and the ignition switch. The engine will not start unless this lever is pushed forward.

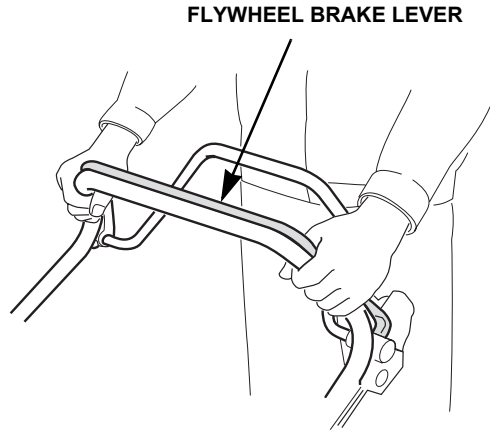

## Drive Clutch Lever

The drive clutch lever engages and disengages the transmission speed selected by the shift lever (page 10).

The drive clutch lever should always be fully engaged or released in a quick, complete motion.

The flywheel brake lever must be engaged before the drive clutch lever can be used.

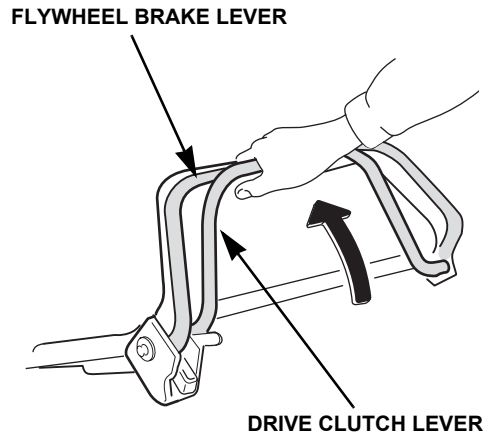

# CONTROLS & FEATURES

---

## Shift Lever

The shift lever selects and controls the mower's drive speed.

- 1 (slow) For mowing thick grass or maneuvering in small areas.
- 2 (medium) For intermediate self-propelled mowing speed.
- 3 (fast) For maximum self-propelled transport speed.

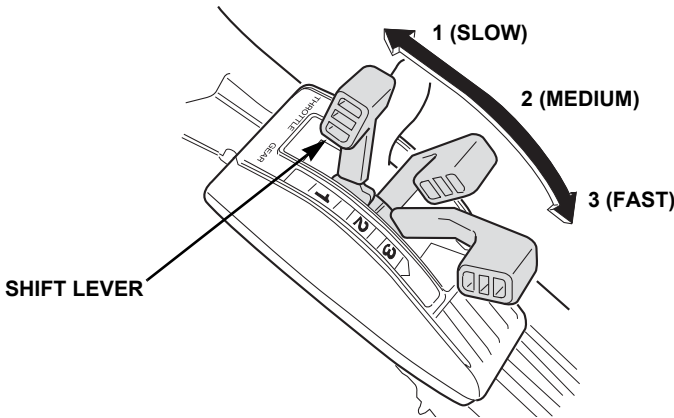

## Cutting Height Adjustment Levers

Each wheel of the mower can be adjusted to one of six settings. The cutting height figures are approximate. The actual height of cut grass will vary with lawn and soil conditions.

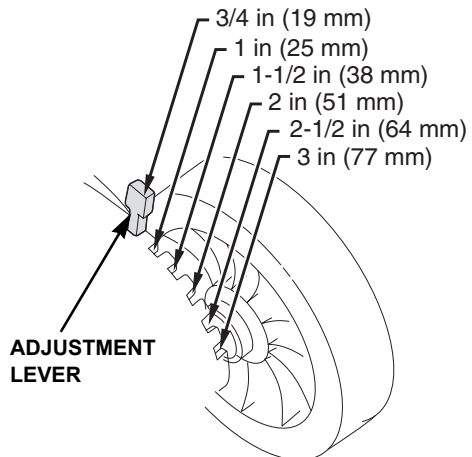

# BEFORE OPERATION

## ARE YOU READY TO GET STARTED?

Your safety is your responsibility. A little time spent in preparation will significantly reduce your risk of injury.

### Knowledge

Read and understand this manual. Know what the controls do and how to operate them.

Familiarize yourself with the lawn mower and its operation before you begin using it. Know how to quickly shut off the lawn mower in case of an emergency.

## IS YOUR LAWN MOWER READY TO GO?

For your safety, and to maximize the service life of your lawn mower, it is very important to take a few moments before you operate the lawn mower to check its condition. Be sure to take care of any problem you find, or have your servicing dealer correct it, before you operate the lawn mower.

### **WARNING**

Improperly maintaining this lawn mower, or failing to correct a problem before operation, could cause a malfunction in which you could be seriously injured.

Always perform a preoperation inspection before each operation, and correct any problem.

Before beginning your pre-operation checks, be sure the lawn mower is on a level surface.

# BEFORE OPERATION

---

## Check the General Condition of the Lawn Mower:

- Look around and underneath the lawn mower for signs of oil or gasoline leaks.
- Look for signs of damage.
- Check each control for proper operation.
- Check the blades for wear. Replace as necessary (page 30). Check that the blade bolts are tight (page 31).
- Check that all nuts, bolts, screws are tightened.

## Check the Engine

- Check the air cleaner (page 35) and oil level (page 33).
- Check the fuel level (page 43). Starting with a full tank will help to eliminate or reduce operating interruptions for refueling.

## CHECK YOUR WORK AREA

For your safety and the safety of others, always inspect the area before operating the lawn mower.

### Objects

Anything which can be picked up by the blade and thrown is a potential hazard to you and others. Look for things like stones, sticks, nails, and wire, and remove them from the work area.

### People and Pets

People and animals near the work area can move into your lawn mower's path or into a position where they could be struck by thrown objects. Clear the area of people, especially children and pets. Their safety is your responsibility.

### Work Area

Check the condition of the grass. Adjust your lawn mower ground speed and mowing swath accordingly.

## GET THE MOWER READY

### Handlebar Height Adjustment

1. Adjust handlebar height for a comfortable operating position.
2. Loosen the handlebar locking knobs. Spread the lower ends of the handlebar to release the locating pins.
3. Move the handlebar up or down, so the locating pins engage other holes on the handlebar mounting brackets.
4. Tighten the handlebar locking knobs securely.

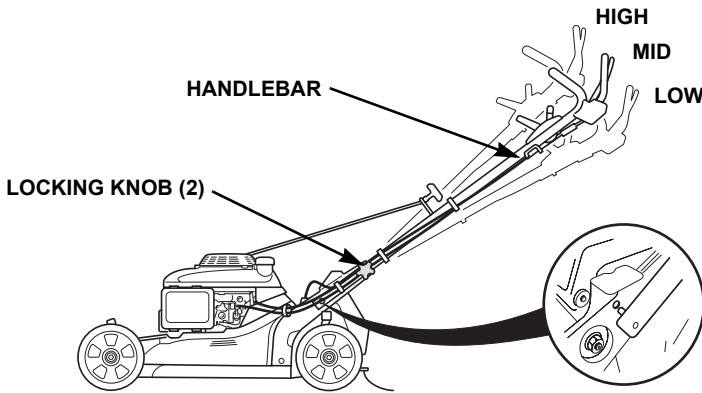

### Mulching Plug

The mulching plug contours the mower deck for efficient mulching.

You can quickly remove the plug to install the grass bag or an optional side-discharge chute.

Raise the discharge guard to remove or install the mulching plug. When installing, be sure the plug is fully inserted, and the discharge guard is closed.

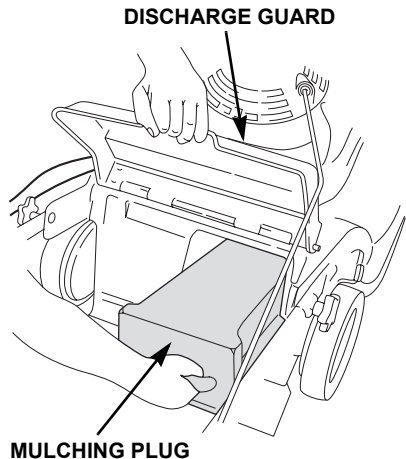

# BEFORE OPERATION

---

## Grass Bag

A lawn mower works like a vacuum cleaner; it blows air through the bag, which traps the grass clippings. Always empty the grass bag before it becomes filled to the limit of its capacity. Bagging performance will diminish after the bag becomes about 90% filled. Also, the bag is easier to empty when it is not packed full.

## Inspection

Inspect the grass bag for tears, holes, and excessive wear. The grass bag wears during normal use and will eventually require replacement. Grass bag replacement is explained on page 32.

## Installation

1. Raise the discharge guard, and remove the mulching plug if it is installed. Hook the grass bag onto the mower deck as shown.
2. Release the discharge guard to secure the grass bag.

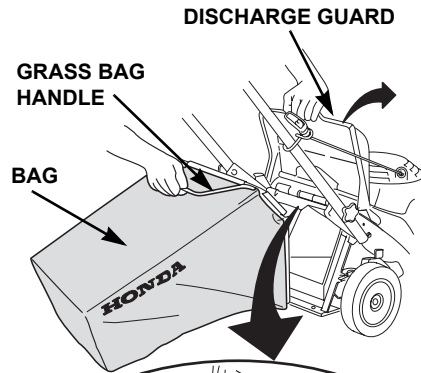

## Removal

1. Raise the discharge guard, grasp the grass bag handle and remove the grass bag.
2. Release the discharge guard.
3. When the grass bag is clear of the discharge guard, you can lift it through the handlebar opening, or you can remove it to the rear of the mower below the handlebar.

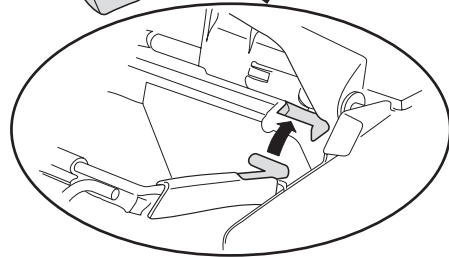



## Cutting Height

### *Bagging/Side-Discharge*

Move all four adjustment levers to the same position.

### *Mulching*

Move the front adjustment levers one position higher than the rear levers.

To adjust cutting height, pull each adjustment lever toward the wheel, and move it into another notch.

If you are not sure what cutting height to select, start with a high setting and check the appearance of the lawn after mowing a small area. Then readjust cutting height if necessary.

ADJUSTMENT LEVERS

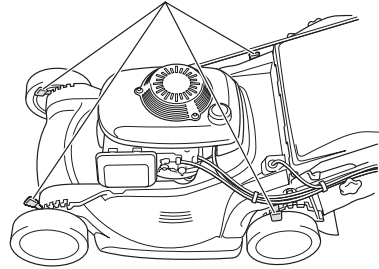

ADJUSTMENT LEVER

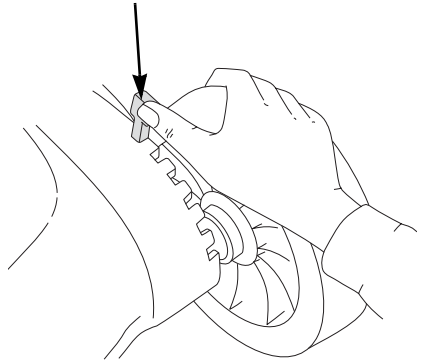

# OPERATION

## MOWING PRECAUTIONS

Before operating the mower for the first time, please review *IMPORTANT SAFETY INFORMATION* (page 4) and *BEFORE OPERATION* (page 11). Even if you have operated other mowers, take time to become familiar with how this mower works and practice in a safe area until you build up your skills. For your safety, avoid starting or operating the engine in an enclosed area such as a garage. Your mower's exhaust contains poisonous carbon monoxide gas which can collect rapidly in an enclosed area and cause illness or death.

## STARTING THE ENGINE

Before starting, always release the drive clutch lever, so the mower will not move forward when you operate the starter.

1. Turn the fuel valve to the ON position.
2. Move the throttle lever to the proper starting position.

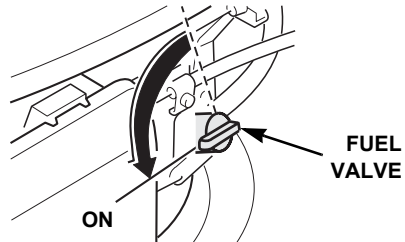

### COLD ENGINE:

Move the throttle lever to the CHOKE position.

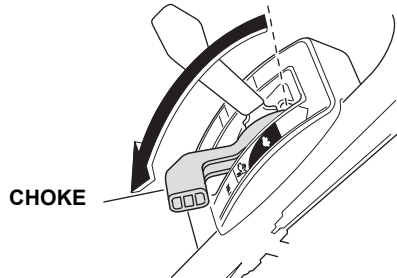

### WARM ENGINE:

Move the throttle lever to the FAST position.

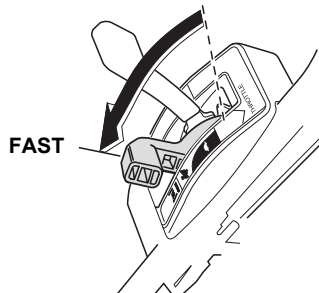

3. Release the drive clutch lever. If the drive clutch lever is engaged, the mower will move forward when you operate the starter.
4. Push forward on the flywheel brake lever and hold it against the handlebar.
5. Pull the starter grip lightly until you feel resistance, then pull briskly. Return the starter grip gently.

Keep your hands and feet away from the mower deck at all times when starting and running the engine.

Continue to hold the flywheel brake lever against the handlebar; the engine will stop if you release the lever.

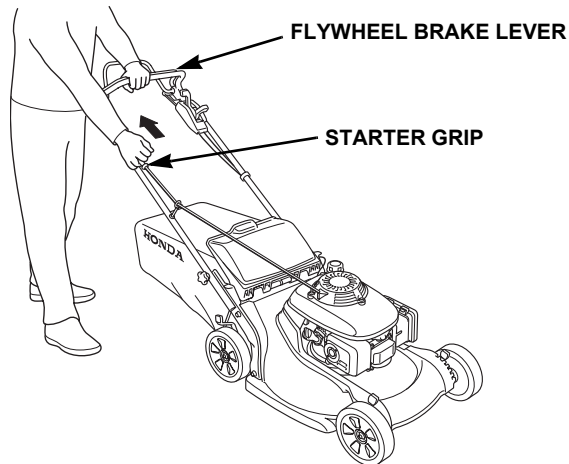

6. If the CHOKE position was used during starting, move the throttle lever away from the CHOKE position as soon as the engine warms up enough to run smoothly without use of the choke. Set the throttle lever at FAST to mow or at SLOW to idle.

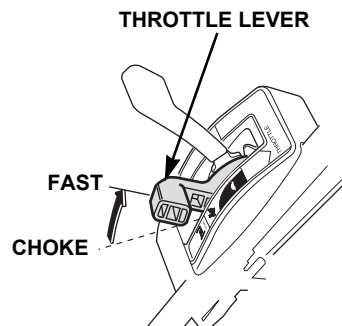

# OPERATION

---

## OPERATING THE CONTROLS FOR MOWING

### Throttle Lever

For best cut quality, always mow with the throttle lever in the FAST position. When the blades rotate at the preset fast speed, it creates a strong fan action that lifts and cuts grass more efficiently. Do not try to increase the preset engine speed: the blade could fracture and come apart.

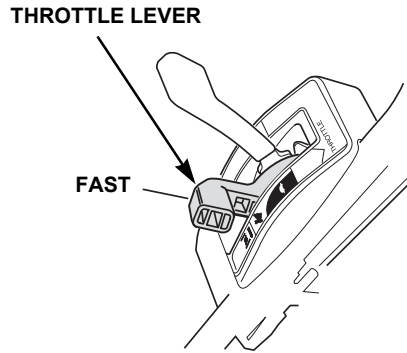

### Flywheel Brake Lever

The lever must be pushed forward against the handlebar to start the engine. The blade starts to rotate when the lever is pushed forward against the handlebar and the recoil starter grip is pulled.

Continue to hold the lever against the handlebar to keep the engine running and the blade rotating.

Release the lever to stop the engine and stop blade rotation.

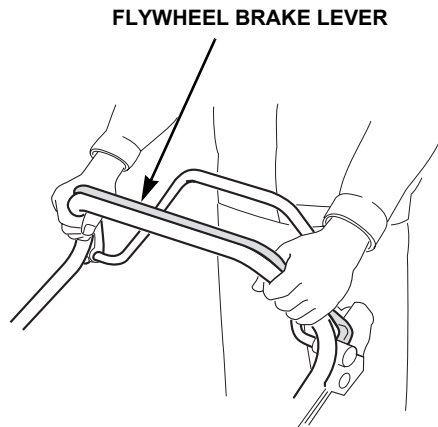

## Drive Clutch Lever

Push the drive clutch lever forward and hold it against the handlebar to propel the mower forward.

Release the drive clutch lever to stop the mower's forward movement.

Always release the drive clutch lever before starting the engine. If the drive clutch is engaged, the mower will move forward when you operate the starter.

Operate the drive clutch lever with a quick and complete motion, so the drive clutch is either fully engaged or released. This will help to extend the service life of the clutch mechanism.

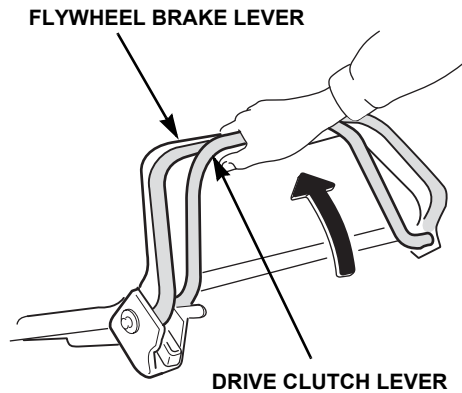

## Shift Lever

Use the shift lever to select the forward speed at which you wish to mow.

You can shift gears without releasing the drive clutch lever, but the transmission may not shift smoothly if the mower is pulling hard. For smoother operation, release the drive clutch lever before shifting gears.

For maximum mowing performance, use 1st and 2nd gears for mowing and 3rd gear for transporting.

Do not use the throttle lever to adjust your mowing speed. The throttle lever must remain in the FAST position for good mowing performance. Otherwise, cut quality suffers.

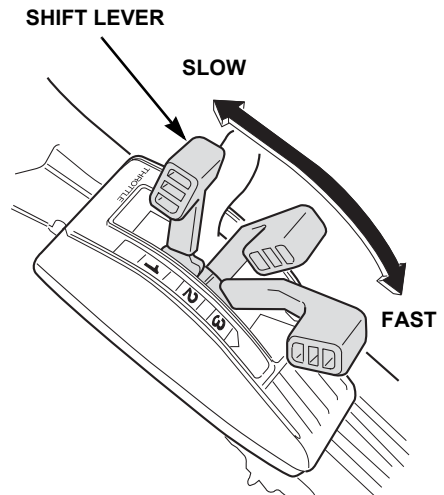

# OPERATION

---

## STOPPING THE ENGINE

1. Move the throttle lever to the SLOW position.

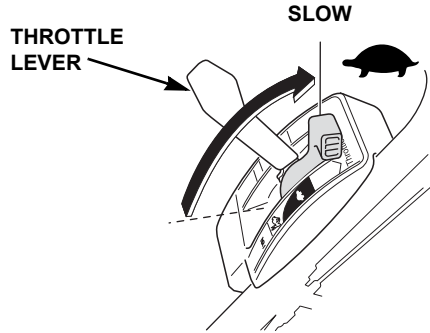

2. Release the flywheel brake lever and the drive clutch lever.

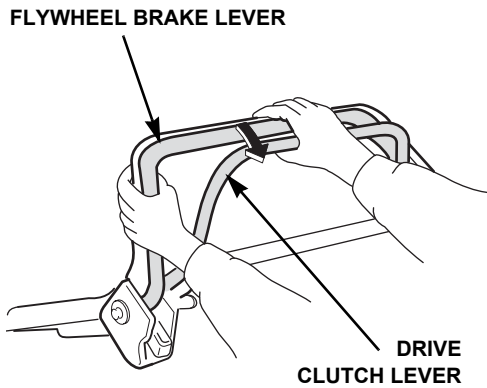

3. When the mower is not in use, turn the fuel valve to the OFF position.

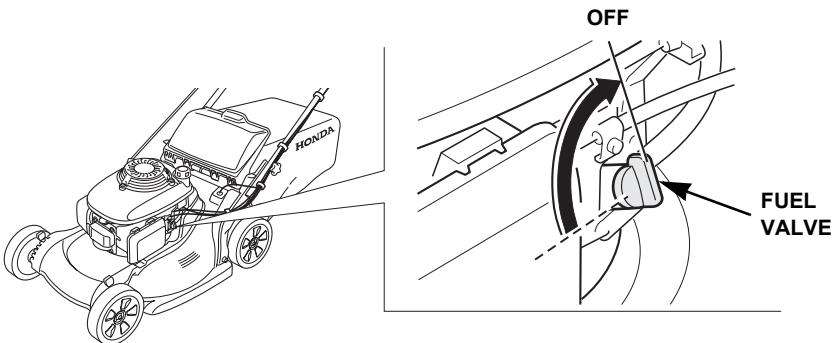

## SAFE MOWING PRACTICES

For your safety, keep all four wheels on the ground, and be careful to avoid losing your footing and your control of the mower. Keep a firm grip on the handlebar, and walk, never run, with the mower. Be very careful when mowing uneven or rough ground.

If stuck, do not kick or shove the mower with your foot. Use the handlebar to control the mower.

### **WARNING**

The blade is sharp and spins at high speed.

A spinning blade can cut you severely and can amputate fingers and toes.

- Wear protective footwear.
- Keep your hands and feet away from the mower deck while the engine is running.
- Stop the engine before performing any adjustment, inspection, or maintenance.

### **Slopes**

Mow across slopes, not up and down. Avoid steep slopes (more than 20°), and be careful when changing direction. Mowing on a slope when the grass is damp or wet could cause you to slip, fall, and lose control of the mower.

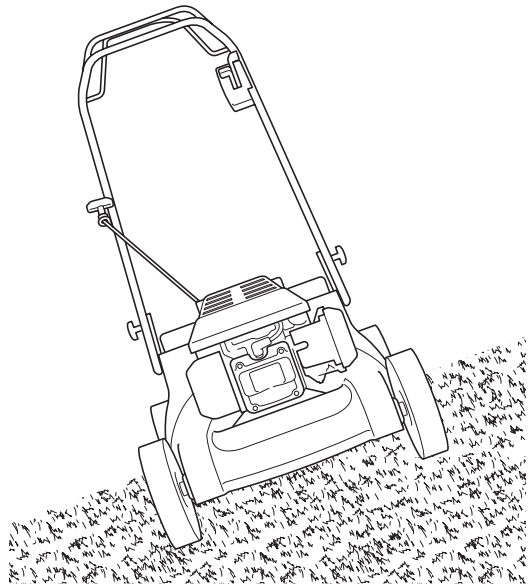

# OPERATION

---

## **Obstacles**

Use the side of the mower to cut close to large obstacles, such as fences or walls.

Release the drive clutch lever to disengage the drive when mowing around trees and other obstacles. Push the mower around obstacles for better directional control. Be careful when mowing over obstacles embedded in the lawn, such as sprinkler heads, paving, edging, raised tree roots, etc. Avoid anything that sticks up above the surface of the lawn.

If the blade hits something, or if the mower starts to vibrate, stop the engine immediately, disconnect the spark plug cap, and check for damage (see page 29). Striking objects may damage the blades, bend the crankshaft, and/or break the mower deck or other components. Vibration usually indicates serious trouble.

The *Distributor's Limited Warranty* (page 66) does not cover parts damaged by accident or collision.

## **Gravel and Loose Objects**

Gravel, loose stones, and landscaping material can be picked up by the mower and thrown many feet with enough force to cause serious personal injury and/or property damage. The best way to prevent potential injury from thrown objects is to release the blade control lever to stop the blades before reaching areas with gravel, loose stones, or landscaping material.



## MOWING TIPS

### When to Mow

Most grasses should be mowed when they have grown 1/2 to 1 inch above their recommended height.

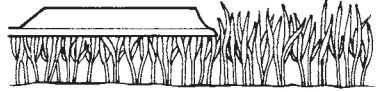

More frequent mowing is required for mulching than for bagging. For best results, you may need to mow the lawn twice a week during the growing season.

### Cutting Height

Consult a local nursery or lawn and garden center for cutting height recommendations and advice about specific types of grasses and growing conditions in your area.



LONG ENOUGH

If you look closely, you'll see that most grass has stems and leaves. If you cut off the leaves, you'll scalp the lawn. Let the grass recover between mowings. Your mower will work better, and your lawn will look better.



TOO SHORT

If your grass gets too tall, cut it once at the highest cutting height setting, then mow again in 2 or 3 days. Don't take off more than one third of total grass height in any one mowing, or brown patches may develop.

Cutting height adjustment is explained on page 15.

### Cutting Width

For an even lawn finish, overlap each mowing swath by a few inches. If the grass is very tall or thick, use more overlap and a narrower mowing swath.

# OPERATION

---

## **Blade Speed**

The blade must spin very fast to cut properly. Always use the FAST throttle setting, and keep the engine running at maximum rpm.

If engine speed drops, it could mean the engine is being overloaded by the blade trying to cut too much grass. Mow a narrower swath, move the mower slower, or raise the cutting height.

## **Blade Sharpness**

A sharp blade cuts cleanly. A dull blade tears the grass, leaving shredded ends that turn brown. When your blade doesn't cut cleanly anymore, have it sharpened or replaced.

## **Dry Grass**

If the ground is too dry, mowing will stir up a lot of dust. Besides being unpleasant to work in, too much dust will clog the air filter. If dust is a problem, water your lawn the day before mowing. Mow when the grass is dry to your touch, but the soil is still moist.

## **Wet Grass**

Wet grass is slippery and can make you lose your footing. Also, wet grass clippings will clog the mower deck and collect in clumps on the lawn. Always wait for wet grass to dry before mowing.

## **Fallen Leaves**

Your mower can be used to pick up fallen leaves for disposal. If using the mower to bag large amounts of fallen leaves, and not for mowing, set the cutting height adjustment levers so the front of the mower deck is one or two settings higher than the rear. An optional leaf shredder is available (page 65) that is used with the grass bag. Be sure there are no obstacles, including rocks, hidden under the leaves.

If you want to mulch fallen leaves into your lawn, don't let the leaf cover get too deep before you begin. For best results, start mulching while grass still shows through the leaf cover. In places where fallen leaves completely cover the grass, remove the leaves by raking, or install a grass bag, so your mower can pick them up for disposal.

## **Clogged Mower Deck**

Before clearing a clogged mower deck, stop the engine and turn the fuel valve to the OFF position. With the spark plug cap disconnected, tilt the mower so the air cleaner side is up.

Clear a clogged deck with a stick, not your hands.

## Mowing Patterns

Your Honda mower will work most efficiently if you use the following mowing patterns as much as possible. Mower deck and equipment design, and the direction in which the blade rotates, cause these mowing patterns to give the best results.

### **Mulching**

Use a counterclockwise mowing pattern. If the lawn has an irregular shape, or many obstacles, divide it into sections where you can use counterclockwise mowing patterns.

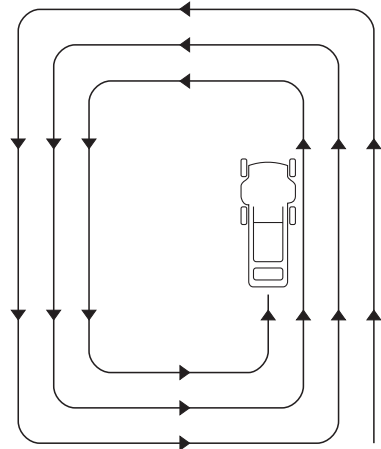

**MULCHING PATTERN**

### **Bagging**

Use a clockwise mowing pattern. This will give the best bagging performance, leaving the least amount of clippings on the lawn.

### **Side-Discharge Mowing**

(requires optional side-discharge chute—see page 65)

Where possible, use the same mowing pattern recommended for bagging. If the lawn has an irregular shape, or many obstacles, divide it into sections where clippings will be discharged away from uncut areas. This will prevent clippings from piling up in the path of the mower.

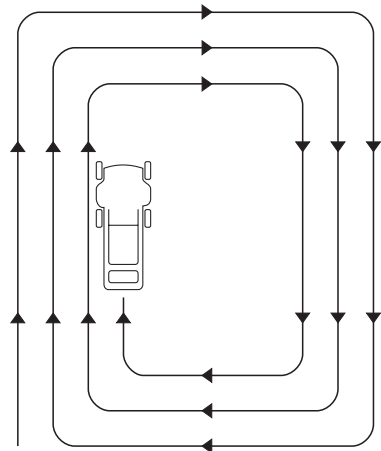

**BAGGING & SIDE-DISCHARGE PATTERN**

# SERVICING YOUR LAWN MOWER

## THE IMPORTANCE OF MAINTENANCE

Good maintenance is essential for safe, economical, and trouble-free operation. It will also help reduce air pollution.

### **WARNING**

Improper maintenance, or failure to correct a problem before operation, can cause a malfunction in which you can be seriously hurt or killed.

Always follow the inspection and maintenance recommendations and schedules in this owner's manual.

To help you properly care for your mower, the following pages include a maintenance schedule, routine inspection procedures, and simple maintenance procedures using basic hand tools. Other service tasks that are more difficult, or require special tools, are best handled by professionals and are normally performed by a Honda technician or other qualified mechanic.

The maintenance schedule applies to normal operating conditions. If you operate your mower under severe conditions, such as sustained high-load or high-temperature operation, or use in unusually wet or dusty conditions, consult your servicing dealer for recommendations applicable to your individual needs and use.

**Maintenance, replacement, or repair of the emission control devices and systems may be performed by any engine repair establishment or individual, using parts that are “certified” to EPA standards.**

## MAINTENANCE SAFETY

Some of the most important safety precautions follow. However, we cannot warn you of every conceivable hazard that can arise in performing maintenance. Only you can decide whether or not you should perform a given task.

### **WARNING**

Failure to properly follow maintenance instructions and precautions can cause you to be seriously hurt or killed.

Always follow the procedures and precautions in this owner's manual.

### Safety Precautions

- Make sure the engine is off before you begin any maintenance or repairs. This will eliminate several potential hazards:
  - **Carbon monoxide poisoning from engine exhaust.**  
Be sure there is adequate ventilation whenever you operate the engine.
  - **Burns from hot parts.**  
Let the engine and exhaust system cool before touching.
  - **Injury from moving parts.**  
Do not run the engine unless instructed to do so.
- Read the instructions before you begin, and make sure you have the tools and skills required.
- To reduce the possibility of fire or explosion, be careful when working around gasoline. Use only a nonflammable solvent, not gasoline, to clean parts. Keep cigarettes, sparks, and flames away from all fuel-related parts.

Remember that an authorized Honda servicing dealer knows your mower best and is fully equipped to maintain and repair it.

To ensure the best quality and reliability, use only new, genuine Honda parts or their equivalents for repair and replacement.

# SERVICING YOUR LAWN MOWER

## MAINTENANCE SCHEDULE

ITEM	REGULAR SERVICE PERIOD		Before each use	First month or 5 hours	First 25 hours	Every 50 hours	Every 100 hours	Every 150 hours	See page
	Perform at every indicated interval								
Blades	Inspect condition		O						29
	Check bolt torque		O						31
Grass bag	Check		O						32
Engine oil	Check		O						33
	Change			O		O (1)			34
Air cleaner	Check		O						35
	Clean				O (1)	O (1)			
	Replace filter							O	
Spark plug	Check-Adjust						O		36
	Replace							O	
Spark arrester (optional equipment)	Clean-Inspect						O		38
Valve clearance	Check-Adjust							O (2)	–
Throttle cable	Inspect-Adjust						O (2)		–
Idle speed	Check-Adjust							O (2)	–
Flywheel brake	Check operation						O		39
	Adjust cable				O		O		
Drive clutch	Adjust cable				O		O		40
Shift cable	Adjust				O		O		41
Combustion chamber	Clean		After every 250 hours (2)						–
Fuel system	Clean tank							O (2)	–
	Check line		Every 2 years [replace if necessary (2)]						–

- (1) Service more frequently when used in dusty areas.
- (2) These items should be serviced by an authorized Honda servicing dealer, unless you have the proper tools and are mechanically proficient. Refer to the Honda shop manual for service procedures.

## BLADES

### Inspection

1. Move the fuel valve to the OFF position (page 8) and disconnect the spark plug cap from the spark plug (page 36).
2. Tilt the mower to the right, so the carburetor side is up. This will help to prevent fuel leakage and hard starting.
3. Inspect blades for wear and damage.

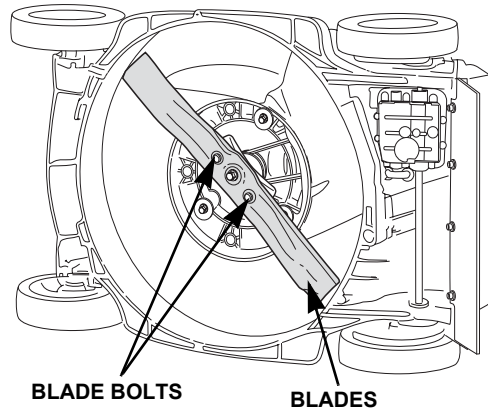

### **⚠ WARNING**

A worn, cracked, or damaged blade can break, and pieces of the damaged blade can become dangerous projectiles.

Thrown objects can cause serious injury.

Inspect the blade regularly, and do not operate the mower with a worn or damaged blade.

A dull blade can be sharpened, but a blade that is worn out, bent, cracked, or otherwise damaged must be

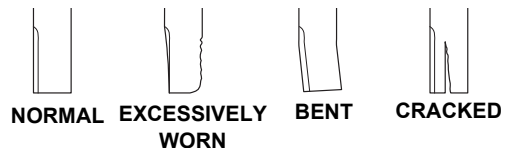

replaced. A worn or damaged blade can break, causing blade pieces to be thrown from the mower.

When a blade needs sharpening or replacement, take the lawn mower to an authorized Honda servicing dealer. Or, if you have a torque wrench, you can remove and install the blades yourself (page 30).

4. Check that the blade bolts are tight (page 31).

# SERVICING YOUR LAWN MOWER

---

## Blade Removal and Installation

If you remove the blades for sharpening or replacement, you will need a torque wrench for installation. Wear heavy gloves to protect your hands.

**BLADE SHARPENING:** To avoid weakening the blades, or causing imbalance or poor cutting, the blades should be sharpened by trained staff at an authorized Honda servicing dealer.

**BLADE REPLACEMENT:** Use genuine Honda replacement blades or their equivalent (page 65).

### ***Blade Removal***

1. Turn the fuel valve OFF. Disconnect the spark plug cap, then tilt the mower to the right side, so the carburetor side is up. This will help to prevent fuel leakage and hard starting due to carburetor flooding.
2. Remove the two blade bolts with a 14 mm socket wrench. Use a wooden block to prevent the blades from turning when removing the bolts. Remove the blades.

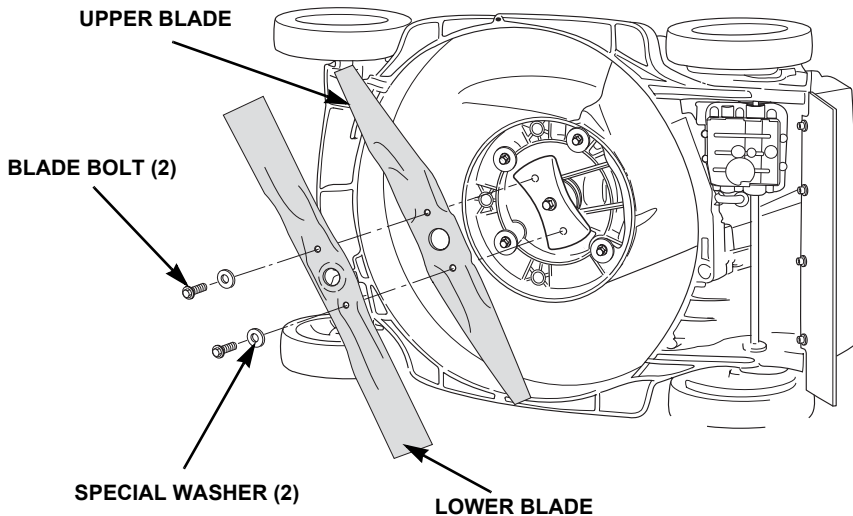



## **Blade Installation**

1. Clean dirt and grass from around the blade mounting area.
2. Install the blades using the two blade bolts and special washers as shown. Be sure to install the special washers with the concave side toward the blades and the convex side toward the bolts.

The blade bolts and washers are specially designed for this application. When replacing bolts and washers, use only genuine Honda replacement parts.

3. Tighten the blade bolts with a torque wrench. Use a wooden block to prevent the blades from turning when tightening the bolts.

**Blade bolt torque:** 36 ~ 43 ft-lb; 5.0 ~ 6.0 kg-m (49 ~ 59 N·m)

If you do not have a torque wrench, have an authorized Honda servicing dealer tighten the blade bolts before you use the mower. If the blade bolts are overtightened, they could break. If the blade bolts are not tightened enough, they could loosen or come out. In either case, it would be possible for the blades to fly off while you are operating the mower.

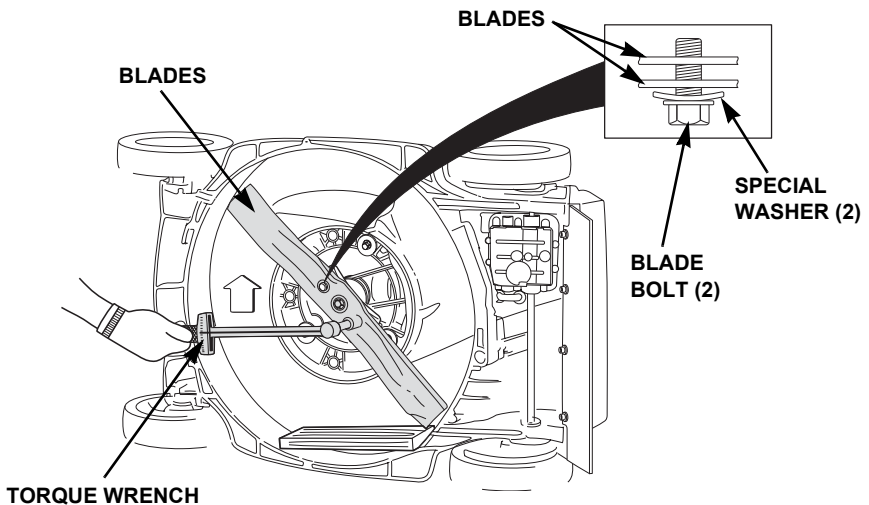

# SERVICING YOUR LAWN MOWER

---

## GRASS BAG CLEANING AND REPLACEMENT

### Grass Bag Cleaning

Wash the bag with a garden hose, and allow it to dry completely before use; a wet bag will clog quickly.

### Grass Bag Replacement

Replace a worn or damaged bag with a Honda replacement bag or its equivalent (page 65).

### Bag Removal

1. Unclip the plastic edges of the bag from the frame.
2. Remove the bag from the frame.

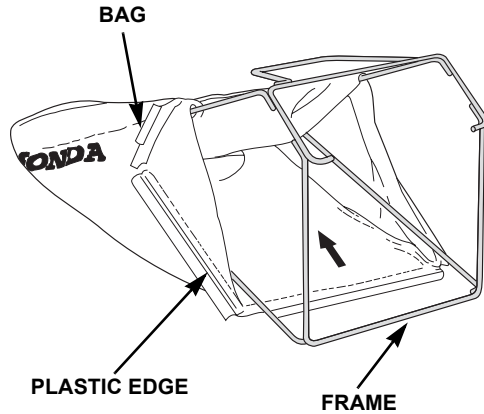

### Bag Installation

1. Insert the bag frame into the bag, as shown.
2. Clip the plastic edges of the bag onto the frame, as shown.

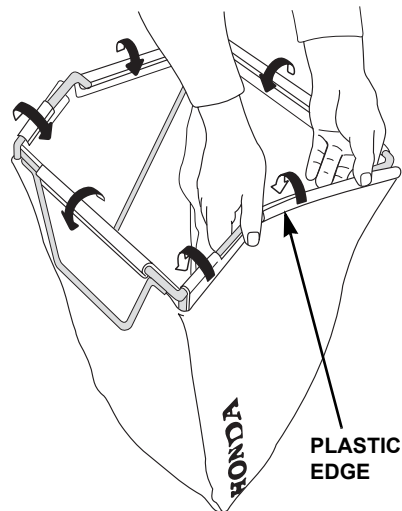

## ENGINE MAINTENANCE

### Engine Oil Level Check

1. Unscrew and remove the filler cap/dipstick and wipe it clean.
2. Insert and remove the dipstick **without screwing it into the filler neck**. Check the oil level shown on the dipstick.
3. If the oil level is low, add oil to reach the upper limit mark on the dipstick. Do not overfill. If the engine is overfilled, the excess oil may get transferred to the air cleaner housing and air cleaner filter.

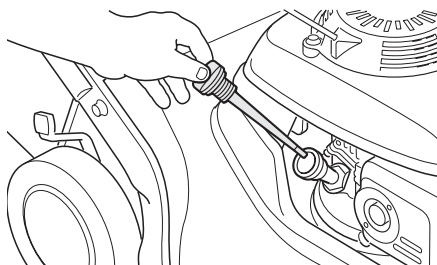

### NOTICE

*Running the engine with a low oil level can cause engine damage.*

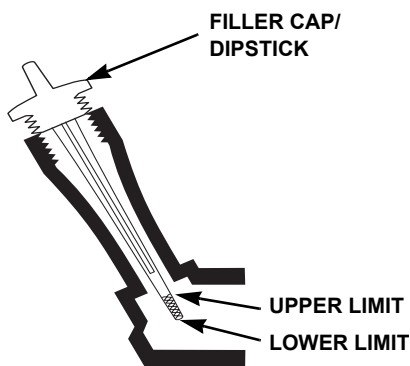

4. Screw in the filler cap/dipstick securely.

### Engine Oil Recommendations

Oil is a major factor affecting performance and service life. Use 4-stroke automotive detergent oil.

SAE 10W-30 is recommended for general use. Other viscosities shown in the chart may be used when the average temperature in your area is within the recommended range.

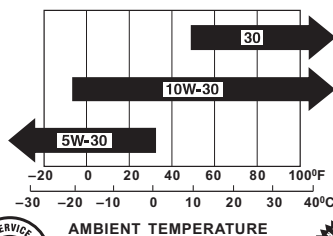

The SAE oil viscosity and service classification are in the API label on the oil container. Honda recommends that you use API SERVICE category SH or SJ oil with the ILSAC "starburst" certification mark displayed on the container.

# SERVICING YOUR LAWN MOWER

---

## Engine Oil Change

Drain the used oil while the engine is warm. Warm oil drains quickly and completely.

1. Turn the fuel valve OFF (page 8). This will reduce the possibility of fuel leakage.
2. Wipe the oil filler area clean, then remove the oil filler cap/dipstick.
3. Place a suitable container next to the mower to catch the used oil, then tilt the mower on its right side.

The used oil will drain through the filler neck. Allow the oil to drain completely.

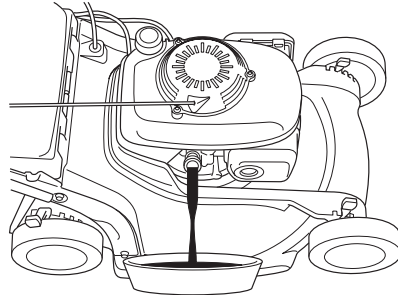

Please dispose of used motor oil and the containers in a manner that is compatible with the environment. We suggest you take it in a sealed container to your local recycling center or service station for reclamation. Do not throw it in the trash, pour it on the ground or down a drain.

4. Fill with the recommended oil. Do not overfill. Measure the oil level as shown on page 33.

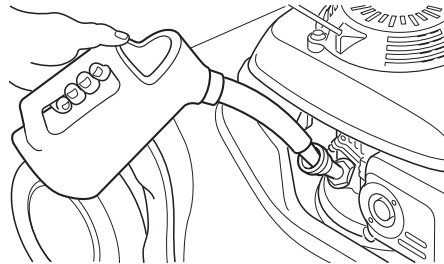

### **NOTICE**

*Using nondetergent oil can shorten the engine's service life, and using 2-stroke oil can damage the engine.*

## Air Cleaner Service

A dirty air filter will restrict air flow to the carburetor, reducing engine performance. If you operate the mower in very dusty areas, clean the air filter more often than specified in the MAINTENANCE SCHEDULE (page 28).

### **NOTICE**

*Operating the engine without an air filter, or with a damaged filter, will allow dirt to enter the engine, causing rapid engine wear. This type of damage is not covered by the Distributor's Limited Warranty (page 66).*

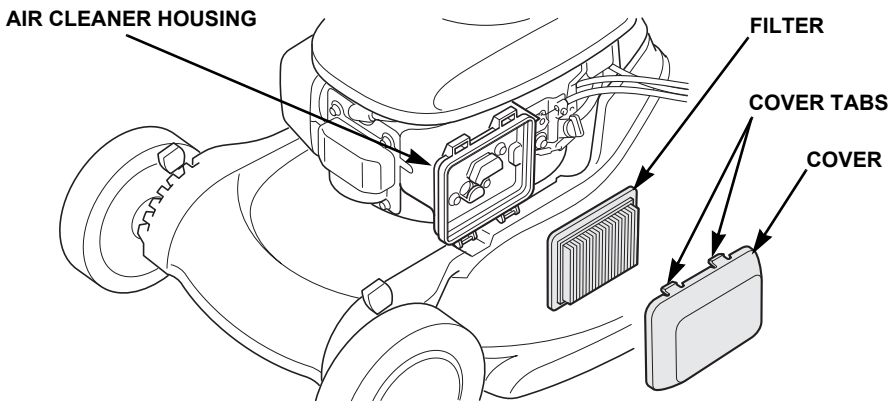

1. Press down on the cover tabs and remove the cover.
2. Remove the filter from the air cleaner housing.
3. Inspect the filter, and replace it if damaged.
4. Clean the filter by tapping the filter several times on a hard surface to remove dirt, or blow compressed air [(not exceeding 30 psi (207 kPa)] through the filter from the inside. Never try to brush off dirt; brushing will force dirt into the fibers.
5. Wipe dirt from the inside of the air cleaner housing and cover, using a moist rag. Be careful to prevent dirt from entering the air duct that leads to the carburetor.
6. Reinstall the filter and cover.

# SERVICING YOUR LAWN MOWER

## Spark Plug Service

RECOMMENDED SPARK PLUGS	REGULAR	RESISTOR*
NGK	BP6ES	BPR6ES
DENSO	W20EP-U	W20EPR-U

\*Resistor spark plugs reduce interference with radio and TV reception.

### NOTICE

*Incorrect spark plugs can cause engine damage.*

For good performance, the spark plug must be properly gapped and free of deposits.

1. Disconnect the spark plug cap and remove any dirt from around the spark plug area.

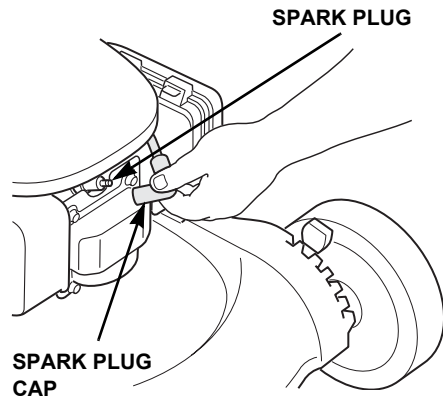

2. Remove the spark plug with a 13/16 in (21 mm) spark plug wrench.
3. Inspect the spark plug. Replace it if the electrodes are worn, or if the insulator is cracked or chipped.

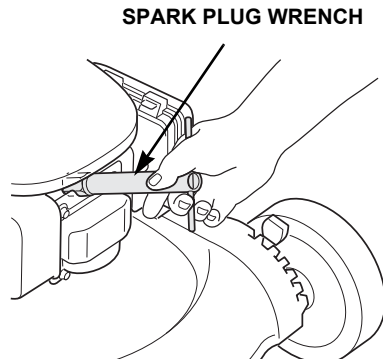

# SERVICING YOUR LAWN MOWER

4. Measure the spark plug electrode gap with a suitable gauge. The gap should be 0.028 ~ 0.031 in (0.7 ~ 0.8 mm). Correct the gap, if necessary, by carefully bending the side electrode.
5. Install the spark plug carefully, by hand, to avoid cross-threading.
6. After the spark plug seats, tighten with a 13/16 in (21 mm) spark plug wrench to compress the washer.

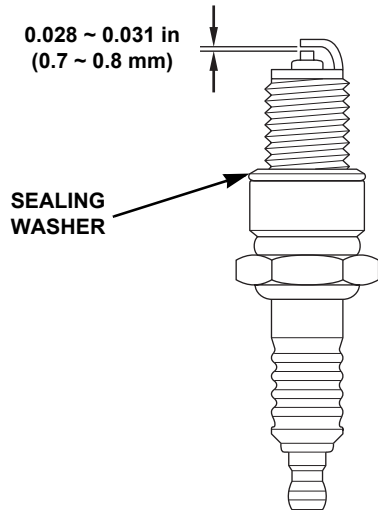

If reinstalling the old spark plug, tighten 1/8 to 1/4 turn after the spark plug seats.

If installing a new spark plug, tighten 1/2 turn after the spark plug seats to compress the washer.

## **NOTICE**

*A loose spark plug can overheat and damage the engine. Overtightening the spark plug can damage the threads in the cylinder head.*

7. Install the spark plug cap on the spark plug.

# SERVICING YOUR LAWN MOWER

---

## Spark Arrester Service (optional equipment)

Your lawn mower engine is not factory-equipped with a spark arrester. In some areas, it is illegal to operate an engine without a spark arrester. Check local laws and regulations. An optional USDA approved spark arrester is available from an authorized Honda servicing dealer.

The spark arrester must be serviced every 100 hours to keep it functioning as designed.

1. Allow the engine to cool and disconnect the spark plug cap to prevent accidental starting.
2. Remove the three flange bolts and the heat shield. Remove the two set screws and the spark arrester from the muffler.
3. Check for carbon deposits on the spark arrester and the exhaust port. Brush carbon deposits away. Be careful to avoid damaging the spark arrester screen.
4. Installation is the reverse of removal. Tighten all hardware securely.
5. Reconnect the spark plug cap.

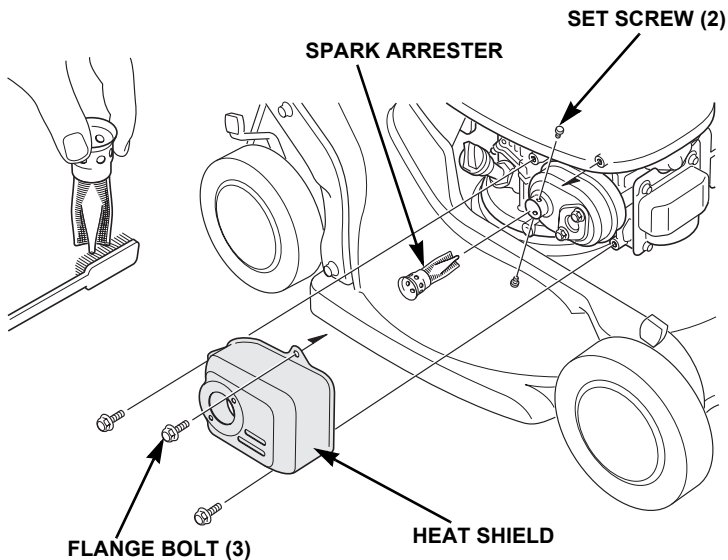



## CONTROL CABLE ADJUSTMENTS

### Flywheel Brake Cable Adjustment

Measure free play at the top of the flywheel brake lever. Free play should be  $3/16 \sim 3/8$  in (5 ~ 10 mm). If adjustment is necessary:

1. Loosen the lock nuts with a 10 mm wrench, and move the adjuster up or down as required.
2. Tighten the lock nuts and recheck free play.
3. Start the engine outdoors. Move the throttle to FAST. Release the flywheel brake lever; the engine should stop quickly.

If the flywheel brake does not operate properly with the correct cable adjustment, take the mower to an authorized Honda servicing dealer for repair.

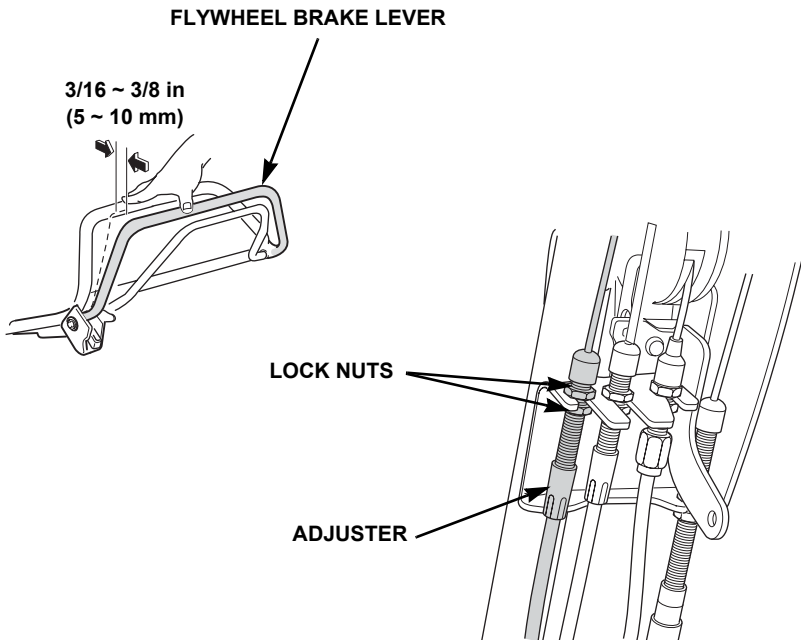

# SERVICING YOUR LAWN MOWER

---

## Drive Clutch Cable Adjustment

Measure free play at the top of the lever, as shown. Free play should be  $1/16 \sim 3/16$  in ( $1 \sim 5$  mm). If adjustment is necessary:

1. Loosen the lock nuts with a 10 mm wrench, and move the adjuster up or down as required.
2. Tighten the lock nuts and recheck free play.
3. Start the engine outdoors, and operate the drive clutch lever. Check that the drive clutch engages and releases properly.

If the drive clutch does not operate as it should, with correct cable adjustment, take the mower to an authorized Honda servicing dealer for repair.

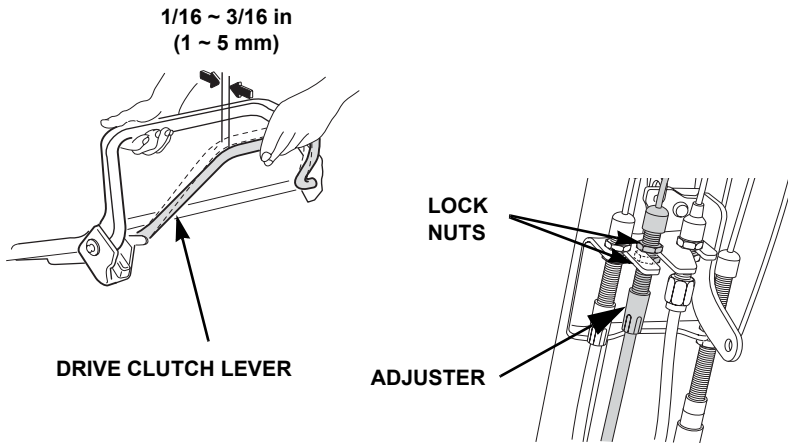

## Shift Cable Adjustment

Shift cable adjustment is necessary if the shift lever will not smoothly select each gear.

1. Starting from 3rd gear, cycle the shift lever through all three gears and listen for the transmission detent click sound for each gear.
2. From 3rd gear, move the shift lever back to 2nd then to the 1st gear position and listen for the 1st gear transmission detent click. The shift lever should select 1st gear (indicated by the click sound) just before contacting the stopper plate. Actual distance should be  $1/64 - 5/64$  in ( $.5 - 2$  mm).
3. If the above conditions are not met, loosen the lock nuts with a 10 mm wrench and move the adjuster up or down as necessary. Tighten the lock nuts and recheck shift lever operation.
4. Operate the mower outdoors and move the shift lever into each gear. Release the drive clutch lever before moving the shift lever. Make sure the transmission shifts properly into all three gears.

If the transmission does not shift properly, with the correct cable adjustment, take the mower to an authorized Honda servicing dealer for repair.

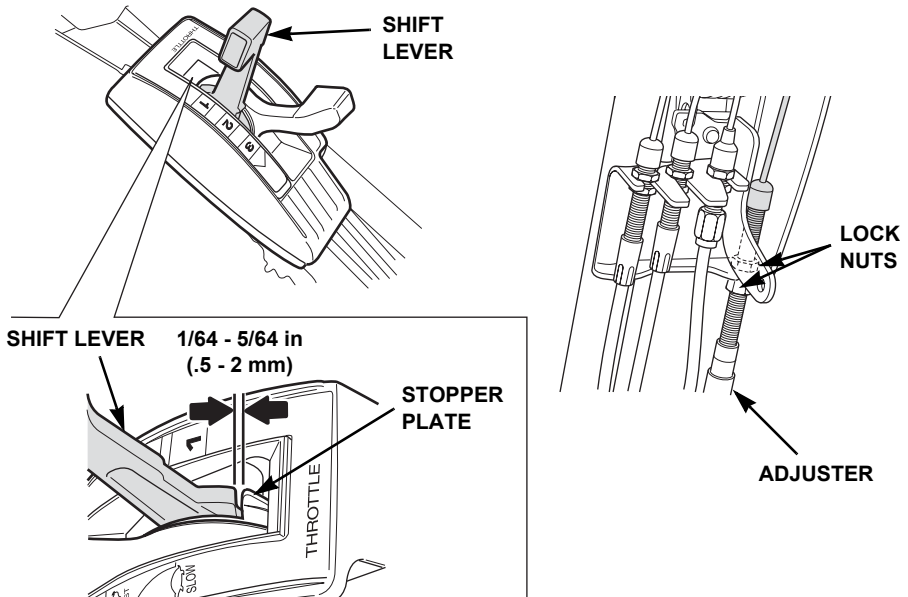

# SERVICING YOUR LAWN MOWER

## THROTTLE CABLE INSPECTION

Throttle cable adjustment is necessary if the throttle lever does not operate the choke properly. Perform the inspection and adjustment with the engine stopped.

You can inspect choke operation by observing the movement of the choke arm, which is located on top of the carburetor.

1. Move the throttle lever to the FAST position.
2. Remove the air cleaner cover (page 35).

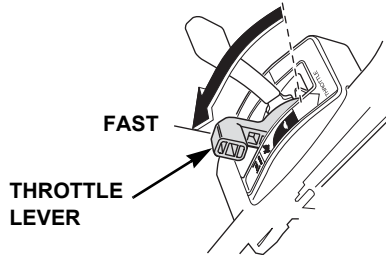

3. Use a feeler gauge and measure the clearance between the control choke arm and the control lever. The clearance should be 0 ~ 0.040 in (0 ~ 1 mm).

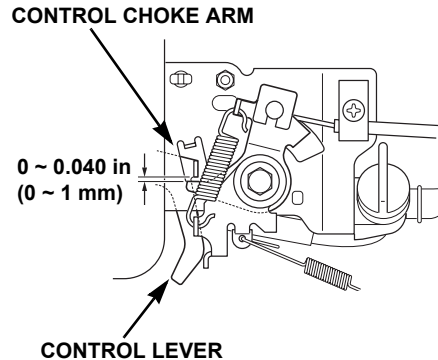

4. To adjust the clearance, loosen the lock nuts with a 10 mm wrench. Move the adjuster up or down as required to obtain the proper clearance. Tighten the lock nuts.

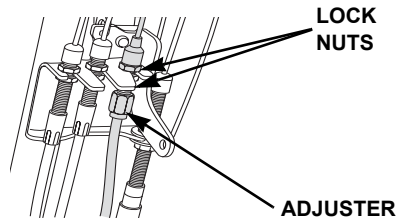

## FUEL SYSTEM

### Refueling

**Fuel tank capacity:** 0.29 US gal (1.1 ℓ)

If the fuel level is low, refuel in a well-ventilated area with the engine stopped. If the engine has been running, allow it to cool first.

To refuel, remove the fuel tank cap, and fill the tank with gasoline to the bottom of the filler neck. Refuel carefully to avoid spilling fuel. Do not overfill. There should be no fuel in the filler neck. After refueling, tighten the fuel tank cap securely.

### **⚠ WARNING**

Gasoline is highly flammable and explosive.

You can be burned or seriously injured when handling fuel.

- Stop the engine and keep heat, sparks, and flame away.
- Handle fuel only outdoors.
- Wipe up spills immediately.

Never refuel the engine inside a building where gasoline fumes may reach flames or sparks. Keep gasoline away from appliance pilot lights, barbecues, electric appliances, power tools, etc.

Spilled fuel is not only a fire hazard, it causes environmental damage. Wipe up spills immediately.

Move at least 10 feet (3 meters) away from the fueling source and site before starting the engine.

### **NOTICE**

*Fuel can damage paint and plastic. Be careful not to spill fuel when filling your fuel tank. Damage caused by spilled fuel is not covered by the Distributor's Limited Warranty (page 66).*

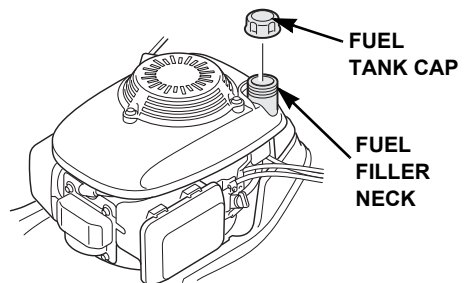

# SERVICING YOUR LAWN MOWER

---

## Fuel Recommendations

**Use unleaded gasoline with a pump octane rating of 86 or higher.**

This engine is certified to operate on unleaded gasoline with a pump octane rating of 86 or higher. Unleaded gasoline produces fewer engine and spark plug deposits and extends exhaust system life.

Never use stale or contaminated gasoline or an oil/gasoline mixture. Avoid getting dirt or water in the fuel tank.

Occasionally you may hear light “spark knock” or “pinging” (metallic rapping noise) while operating under heavy loads. This is no cause for concern.

If spark knock or pinging occurs at a steady engine speed, under normal load, change brands of gasoline. If spark knock or pinging persists, see an authorized Honda servicing dealer.

### **NOTICE**

*Running the engine with persistent spark knock or pinging can cause engine damage.*

This is considered misuse, and the *Distributor’s Limited Warranty* (page 66) does not cover parts damaged by misuse.

For oxygenated fuel information refer to page 58.

## STORAGE PREPARATION

Proper storage preparation is essential for keeping your lawn mower trouble free and looking good. The following steps will help to keep rust and corrosion from impairing your lawn mower's function and appearance, and will make the engine easier to start when you use the lawn mower again.

### Cleaning

1. Wash the lawn mower, including the underside of the mower deck.

#### **Engine**

Wash the engine by hand, and be careful to prevent water from entering the air cleaner.

#### **NOTICE**

- *Using a garden hose or pressure washing equipment can force water into the air cleaner. Water in the air cleaner will soak the filter and can enter the carburetor or engine cylinder, causing damage.*
- *Water contacting a hot engine can cause damage. If the engine has been running, allow it to cool for at least half an hour before washing.*

#### **Mower Deck**

If using a garden hose or pressure washing equipment to clean the mower deck, be careful to avoid getting water into controls and cables, or anywhere near the engine air cleaner or muffler opening.

Before washing the underside of the mower deck, be sure the fuel valve is in the OFF position. Disconnect the spark plug cap. Rest the mower on its right side, so the carburetor side is up. This will help to prevent fuel leakage and hard starting due to carburetor flooding. Wear heavy gloves to protect your hands from the blades.

#### **Grass Bag**

Remove the bag from the mower, and wash it with a garden hose or pressure washing equipment. Allow the bag to dry completely before storage.

2. After washing the lawn mower, wipe dry all accessible surfaces.

## STORAGE

---

3. With the mower in an upright position, start the engine outdoors, and let it run until it reaches normal operating temperature to evaporate any water remaining on the engine.
4. Stop the engine and allow it to cool.
5. After the lawn mower is clean and dry, touch up any damaged paint (touch-up paint part numbers are on page 65), and coat other areas that may rust with a light film of oil. Lubricate the control cable cores with a silicone spray lubricant (page 65).



## Fuel

Gasoline will oxidize and deteriorate in storage. Old gasoline will cause hard starting, and it leaves gum deposits that clog the fuel system. If the gasoline in your mower deteriorates during storage, you may need to have the carburetor and other fuel system components, serviced or replaced.

The length of time that gasoline can be left in your fuel tank and carburetor without causing functional problems will vary with such factors as gasoline blend, your storage temperatures, and whether the fuel tank is partially or completely filled. The air in a partially filled fuel tank promotes fuel deterioration. Very warm storage temperatures accelerate fuel deterioration. Fuel deterioration problems may occur within a few months, or even less if the gasoline was not fresh when you filled the fuel tank.

The *Distributor's Limited Warranty* (page 66) does not cover fuel system damage or engine performance problems resulting from neglected storage preparation.

You can extend fuel storage life by adding a gasoline stabilizer that is formulated for that purpose, or you can avoid fuel deterioration problems by draining all the fuel from the fuel tank and carburetor.

### ***Adding a Fuel Stabilizer***

When adding a fuel stabilizer (page 65), fill the fuel tank with fresh gasoline. If only partially filled, air in the tank will promote fuel deterioration during storage. If you keep a container of gasoline for refueling, be sure that it contains only fresh gasoline.

1. Add fuel stabilizer following the manufacturer's instructions.
2. After adding a fuel stabilizer, run the engine outdoors for 10 minutes to be sure that the treated gasoline has replaced the untreated gasoline in the carburetor.
3. Turn the engine OFF and turn the fuel valve to the OFF position (page 20).

# STORAGE

---

## ***Draining the Carburetor and Fuel Tank***

1. Make sure the fuel valve is OFF (page 8). Remove the carburetor drain bolt with a 10 mm wrench, and drain the fuel from the carburetor bowl into an approved container.

### **⚠ WARNING**

Gasoline is highly flammable and explosive.

You can be burned or seriously injured when handling fuel.

- Stop engine and keep heat, sparks, and flame away.
- Handle fuel only outdoors.
- Wipe up spills immediately.

If you only need to drain the carburetor, skip to step 3.

2. To drain the fuel tank, turn the fuel valve ON (page 8). This will allow fuel in the fuel tank to drain out through the carburetor bowl.
3. After the fuel is completely drained, reinstall the drain bolt.

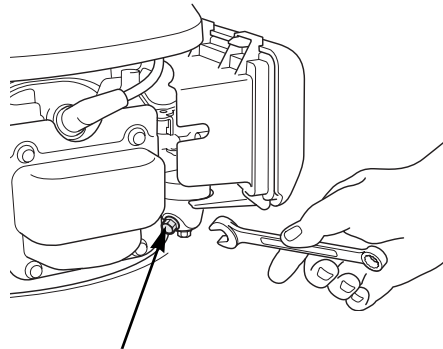

**DRAIN BOLT**

## **Engine Oil**

Change the engine oil (page 34).

## Engine Cylinder

Remove the spark plug (see page 36). Pour a tablespoon (5 ~ 10 cc) of clean engine oil into the cylinder. Pull the starter rope several times to distribute the oil in the cylinder. Reinstall the spark plug.

Pull the starter rope slowly until resistance is felt then return the starter grip gently. This will close the valves so moisture can not enter the engine cylinder.

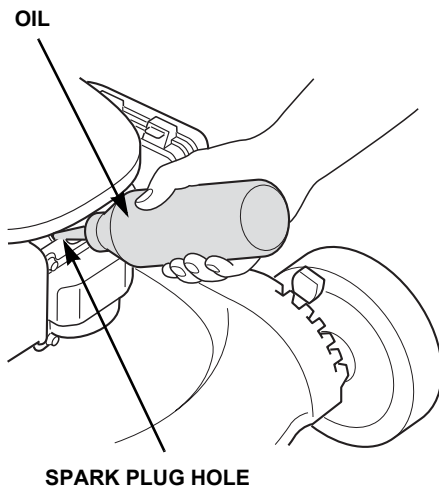

## Handlebar Folding

The handlebar can be folded for storage or transport by loosening the handlebar locking knobs.

1. Remove the grass bag, if so equipped. You can place it on top of the engine, with the bag opening to the front.
2. Loosen the handlebar locking knobs. Spread the handlebar struts to release the locating pins, then swing the handlebar forward. Prevent the cables from getting pinched or kinked.

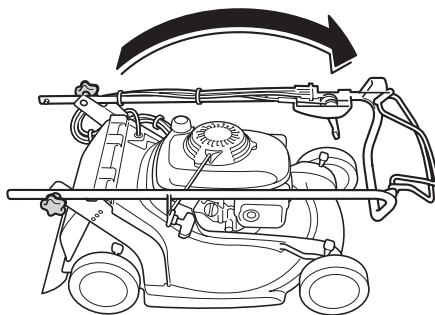

When unfolding the handlebar, be sure to tighten the locking knobs to secure the handlebar in the mowing position.

# STORAGE

---

## PLACING IN STORAGE

If your mower will be stored with gasoline in the fuel tank and carburetor, it is important to reduce the hazard of gasoline vapor ignition. Select a well-ventilated storage area away from any appliance that operates with a flame, such as a furnace, water heater, or clothes dryer. Also avoid any area with a spark-producing electric motor, or where power tools are operated.

If possible, avoid storage areas with high humidity, because that promotes rust and corrosion.

Make sure the fuel valve is in the OFF position to reduce the possibility of fuel leakage.

Place the mower with its wheels on a level surface. Tilting can cause fuel or oil leakage.

The handlebar can be folded for compact storage (page 49).

With the engine and exhaust system cool, cover the mower to keep out dust. A hot engine and exhaust system can ignite or melt some materials. Do not use sheet plastic as a dust cover. A nonporous cover will trap moisture around the mower, promoting rust and corrosion.

## REMOVING FROM STORAGE

Check your mower as described in *BEFORE OPERATION* (page 11).

If the fuel was drained during storage preparation, fill the tank with fresh gasoline. If you keep a container of gasoline for refueling, be sure that it contains only fresh gasoline. Gasoline oxidizes and deteriorates over time, causing hard starting.

If the cylinder was coated with oil during storage preparation, the engine will smoke briefly at startup. This is normal.

# TRANSPORTING

## BEFORE LOADING

If the engine has been running, allow it to cool for at least 15 minutes before loading the mower on the transport vehicle. A hot engine and exhaust system can burn you and can ignite some materials.

1. Turn the fuel valve to the OFF position. This will prevent carburetor flooding and reduce the possibility of fuel leakage.

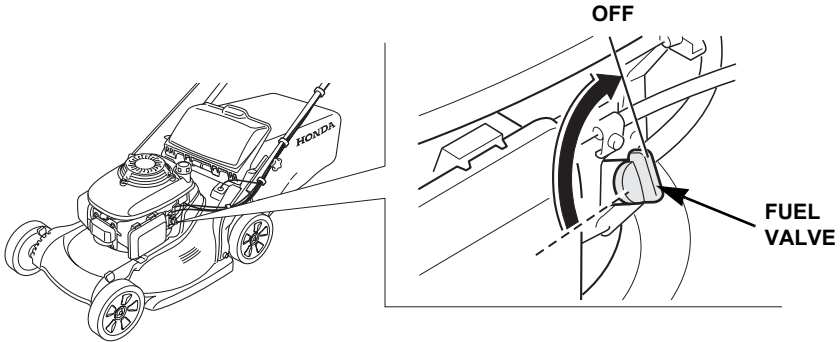

2. If installed, remove the grass bag.

## LOADING AND UNLOADING

If a suitable loading ramp is not available, two people should lift the mower on and off the transport vehicle while holding the mower level.

Position the mower so all four wheels are on the bed of the transport vehicle. Tie the mower down with rope or straps, and block the wheels. Keep the tie-down rope or straps away from the controls, adjustment levers, cables, and the carburetor.

The handlebar can be folded so the mower will take up less space (page 49).

# TAKING CARE OF UNEXPECTED PROBLEMS

## ENGINE PROBLEMS

Engine Will Not Start	Possible Cause	Correction
1. Check control positions.	Fuel valve OFF.	Turn fuel valve ON (page 8).
	Throttle lever in wrong position.	Move throttle lever to CHOKE position, unless the engine is warm (page 16).
	Flywheel brake lever not engaged.	Engage the flywheel brake lever (page 18).
2. Check fuel.	Out of fuel.	Refuel (page 43).
	Bad fuel; mower stored without treating or draining gasoline, or refueled with bad gasoline.	Drain fuel tank and carburetor (page 48). Refuel with fresh gasoline (page 43).
3. Remove and inspect spark plug.	Spark plug faulty, fouled, or improperly gapped.	Gap, or replace spark plug (page 36).
	Spark plug wet with fuel (flooded engine).	Dry and reinstall spark plug.
4. Take the mower to an authorized Honda servicing dealer, or refer to shop manual.	Fuel filter clogged, carburetor malfunction, ignition malfunction, valves stuck, etc.	Replace or repair faulty components as necessary.
Loss of Power	Possible Cause	Correction
1. Check throttle position.	Throttle not set to FAST.	Move throttle to FAST (page 18).
2. Check grass condition.	Grass too tall or wet.	Raise cutting height (page 10), cut narrower swath (page 23), use slower ground speed (page 24), cut more frequently or when grass is dry.
3. Check under mower deck.	Mower deck clogged.	Clear out mower deck (page 24).
4. Check air filter.	Air filter clogged.	Clean or replace air filter (page 35).
5. Check fuel.	Bad fuel; mower stored without treating or draining gasoline, or refueled with bad gasoline.	Drain fuel tank and carburetor (page 48). Refuel with fresh gasoline (page 43).
6. Take mower to an authorized Honda servicing dealer, or refer to shop manual.	Fuel filter clogged, carburetor malfunction, ignition malfunction, valves stuck, etc.	Replace or repair faulty components as necessary.

# TAKING CARE OF UNEXPECTED PROBLEMS

## VIBRATION PROBLEMS

<b>Excessive Vibration</b>	<b>Possible Cause</b>	<b>Correction</b>
1. Check mower deck and blades.	Grass and debris lodged under mower deck.	Clear out mower deck (page 24).
	Blades loose, bent, damaged, or unbalanced by improper sharpening.	Tighten loose blades bolts. Replace damaged blades (page 31).
2. Take the mower to an authorized Honda servicing dealer for repair.	Mechanical damage, such as a bent crankshaft.	Replace or repair faulty components as necessary.

## MOWING AND BAGGING PROBLEMS

<b>Poor Cut Quality or Poor Mowing/Bagging Performance</b>	<b>Possible Cause</b>	<b>Correction</b>
1. Check that the throttle lever is in the FAST position.	Engine speed is too slow to cut well.	Move throttle lever to the FAST position (page 18).
2. Reduce forward speed.	Mower is moving too fast for lawn conditions.	Shift to slow speed (page 19), or push slower.
3. Check cutting height adjustment levers.	Adjustment levers set at different positions.	Set all levers at the same cutting height position (page 15).
4. Check grass bag.	Grass bag overfilled or clogged.	Empty the grass bag. Wash the grass bag if clogged with dirt (page 32).
5. Check mower deck and blades.	Mower deck clogged.	Clean out the mower deck (page 24).
	Blades dull, worn, or damaged.	Sharpen or replace blades if necessary (page 30).
	Wrong blades installed.	Install correct blades (page 31).

# SET-UP

## Unpacking

Remove all the cardboard from around the handlebar.

## Handlebar Setup

Loosen the two knobs on the lower handlebar enough to raise the handlebar into the mowing position.

Select a desired handlebar height adjustment position and tighten the knobs securely.

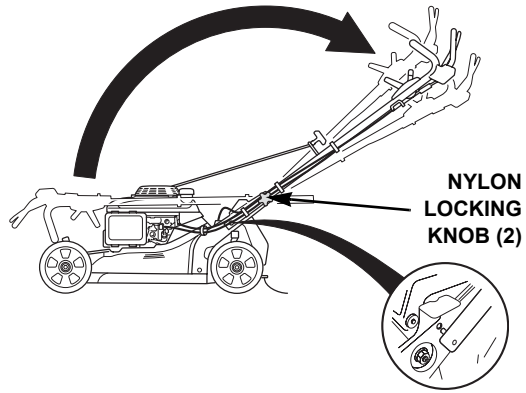

## Grass Bag Assembly

Slide the grass bag frame into the grass bag and install the clips as shown.

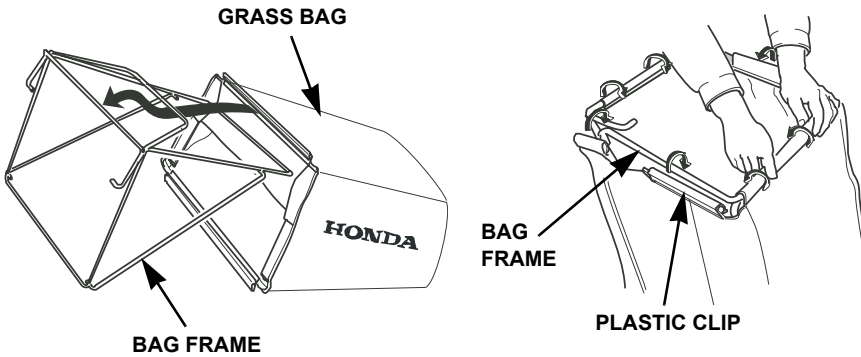

Lift the the discharge guard, remove the mulching plug, then install the grass bag.

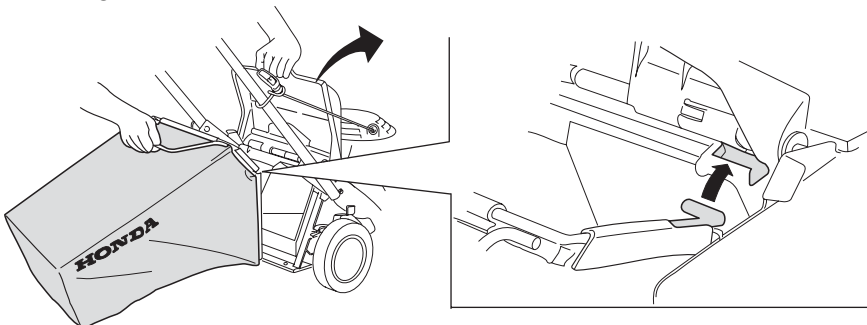



## Engine Oil

The mower is shipped **WITHOUT OIL** in the engine. A bottle of oil is included in the box with your mower.

Add the entire contents of the oil bottle into the oil filler opening. If not using the supplied oil, add enough SAE 10W-30 API service category SH or SJ oil to bring the oil level between the upper and lower limit marks on the dipstick as shown.

**Do not overfill engine oil.** If the engine is overfilled, the excess oil may get transferred to the air cleaner housing and air filter.

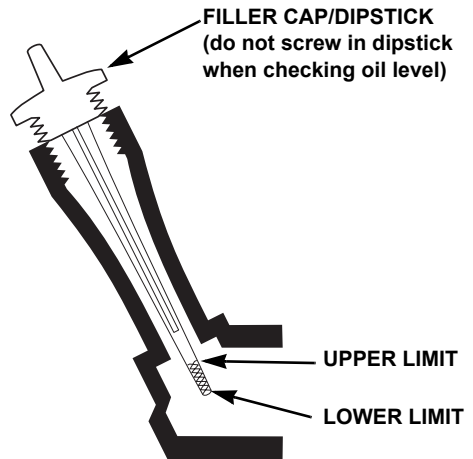
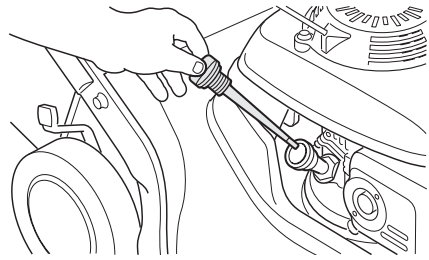

## Fuel

Refer to page 43.

## BEFORE OPERATION

Before using the lawn mower, all mower operator's must read the following chapters and sections:

- **LAWN MOWER SAFETY** (page 4)
- **CONTROLS & FEATURES** (page 7)
- **BEFORE OPERATION** (page 11)
- **OPERATION** (page 16)
- **MAINTENANCE SCHEDULE** (page 28)

# TECHNICAL & CONSUMER INFORMATION

## TECHNICAL INFORMATION

### Serial Number Locations

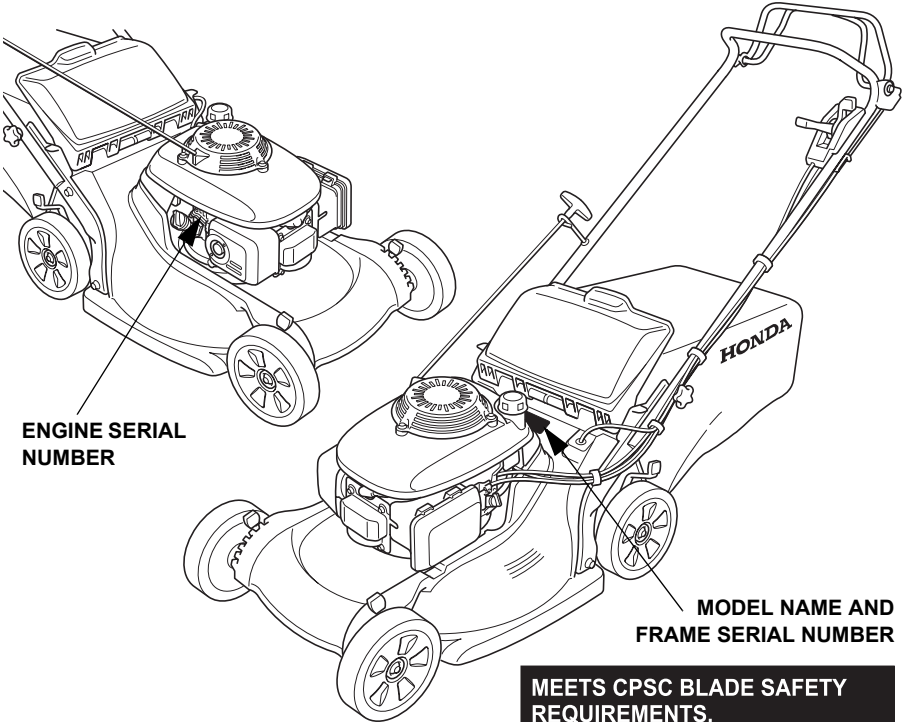

**MEETS CPSC BLADE SAFETY  
REQUIREMENTS.**

MODEL: HRB217TDA                      AG  
SERIAL NO: MAEA — XXXXXXX

AMERICAN HONDA MOTOR CO., INC.  
ALPHARETTA, GA 30005-8847

There are two serial numbers, one for the mower frame and one for the engine. Record the frame and engine serial numbers in the space below. You will need these serial numbers when ordering parts and when making technical or warranty inquiries (page 70).

Engine serial number: \_\_\_\_\_

Frame serial number: \_\_\_\_\_

### **Carburetor Modification for High Altitude Operation**

At high altitude, the standard carburetor air-fuel mixture will be too rich. Performance will decrease, and fuel consumption will increase. A very rich mixture will also foul the spark plug and cause hard starting. Operation at an altitude that differs from that at which this engine was certified, for extended periods of time, may increase emissions.

High altitude performance can be improved by specific modifications to the carburetor. If you always operate your lawn mower at altitudes above 5,000 feet (1,500 meters), have your servicing dealer perform this carburetor modification. This engine when operated at high altitude with the carburetor modifications for high altitude use will meet each emission standard throughout its useful life.

Even with carburetor modification, engine horsepower will decrease about 3.5% for each 1,000-foot (300-meter) increase in altitude. The effect of altitude on horsepower will be greater than this if no carburetor modification is made.

#### **NOTICE**

*When the carburetor has been modified for high altitude operation, the air-fuel mixture will be too lean for low altitude use. Operation at altitudes below 5,000 feet (1,500 meters) with a modified carburetor may cause the engine to overheat and result in serious engine damage. For use at low altitudes, have your servicing dealer return the carburetor to original factory specifications.*

## TECHNICAL & CONSUMER INFORMATION

---

### Oxygenated Fuels

Some conventional gasolines are being blended with alcohol or an ether compound. These gasolines are collectively referred to as oxygenated fuels. To meet clean air standards, some areas of the United States and Canada use oxygenated fuels to help reduce emissions.

If you use an oxygenated fuel, be sure it is unleaded and meets the minimum octane rating requirement.

Before using an oxygenated fuel, try to confirm the fuel's contents. Some states/provinces require this information to be posted on the pump.

The following are the EPA-approved percentages of oxygenates:

#### **ETHANOL — (ethyl or grain alcohol) 10% by volume**

You may use gasoline containing up to 10% ethanol by volume. Gasoline containing ethanol may be marketed under the name "Gasohol".

#### **MTBE — (Methyl Tertiary Butyl Ether) 15% by volume**

You may use gasoline containing up to 15% MTBE by volume.

#### **METHANOL — (methyl or wood alcohol) 5% by volume**

You may use gasoline containing up to 5% methanol by volume, as long as it also contains cosolvents and corrosion inhibitors to protect the fuel system. Gasoline containing more than 5% methanol by volume may cause starting and/or performance problems. It may also damage metal, rubber, and plastic parts of your fuel system.

Fuel system damage or performance problems resulting from the use of an oxygenated fuel containing more than the percentages of oxygenates mentioned above are not covered under warranty.

## EMISSION CONTROL SYSTEM

### Source of Emissions

The combustion process produces carbon monoxide, oxides of nitrogen, and hydrocarbons. Control of hydrocarbons and oxides of nitrogen is very important because, under certain conditions, they react to form photochemical smog when subjected to sunlight. Carbon monoxide does not react in the same way, but it is toxic.

Honda uses lean carburetor settings and other systems to reduce the emissions of carbon monoxide, oxides of nitrogen, and hydrocarbons.

### The U.S. and California Clean Air Act

EPA and California regulations require all manufacturers to furnish written instruction describing the operation and maintenance of emission control systems.

The following instructions and procedures must be followed in order to keep the Honda engine emissions within the emission standards.

### Tampering and Altering

Tampering with or altering the emission control system may increase emissions beyond the legal limit. Some acts that constitute tampering:

- Removal or alteration of any part of intake, fuel, or exhaust system.
- Altering or defeating the governor linkage or speed-adjusting mechanism to cause the engine to operate outside its design parameters.

### Problems That May Affect Emissions

If you are aware of any of the following symptoms, have your engine inspected and repaired by your authorized Honda servicing dealer.

- Hard starting or stalling after starting.
- Rough idle.
- Misfiring or backfiring under load.
- Afterburning (backfiring).
- Black exhaust smoke or high fuel consumption.

## TECHNICAL & CONSUMER INFORMATION

---

### Replacement Parts

The emission control systems on your new Honda engine were designed, built, and certified to conform with EPA and California emission regulations. We recommend the use of genuine Honda parts whenever you have maintenance done. These original-design replacement parts are manufactured to the same standards as the original parts, so you can be confident of their performance. The use of replacement parts that are not of the original design and quality may impair the effectiveness of your emission control system.

A manufacturer of an aftermarket part assumes the responsibility the part will not adversely affect emission performance. The manufacturer or rebuilder of the part must certify that use of the part will not result in a failure of the engine to comply with emission regulations.

### Maintenance

Follow the *MAINTENANCE SCHEDULE* on page 28. Remember that this schedule is based on the assumption that your machine will be used for its designed purpose. Sustained high-load operation will require more frequent service.

## Air Index

An Air Index Information hang tag/label is applied to engines certified to an emission durability time period in accordance with the requirements of the California Air Resources Board.

The bar graph is intended to provide you, our customer, the ability to compare the emissions performance of available engines. The lower the Air Index, the less pollution.

The durability description is intended to provide you with information relating the engine's emission durability period. The descriptive term indicates the useful life period for the engine's emission control system. See your *Emission Control System Warranty* (page 67) for additional information.

<b>Descriptive Term</b>	<b>Applicable to Emissions Durability Period</b>
Moderate	50 hours (0–65 cc) 125 hours (greater than 65 cc)
Intermediate	125 hours (0–65 cc) 250 hours (greater than 65 cc)
Extended	300 hours (0–65 cc) 500 hours (greater than 65 cc)

The Air Index Information hang tag/label must remain on the lawn mower until it is sold. Remove the hang tag before operating the lawn mower.

# TECHNICAL & CONSUMER INFORMATION

## SPECIFICATIONS

### Mower Model

HRB217TDA	Honda rotary mower, 21 inch mower deck, 6.5 bhp, three-speed transmission, zone start, USA market
-----------	---

### Dimensions, Weights and Capacities

Length	68.1 in (1730 mm)
Width at Mower Deck	23-1/4 in (590 mm)
Height	39.0 in (990 mm)
Dry Weight	80.5 lb (36.5 kg)
Cutting Width	21 in (530 mm)
Approximate Cutting Height (adjustable)	3/4 in (19 mm), 1 in (25 mm), 1-1/2 in (38 mm), 2 in (51 mm), 2-1/2 in (64 mm), 3 in (76 mm)
Fuel Tank Capacity	0.29 US gal (1.1 ℓ)
Engine Oil Capacity	0.58 US qt (0.55 ℓ)
Grass Bag Capacity	21.9 US gal (2.4 bushels; 2.9 cu ft; 83 ℓ)

### Engine Design and Performance

Engine Model	GCV190
Engine Type	4-stroke, overhead-camshaft, single-cylinder, forced air-cooled
Displacement	11.4 cu in (190 cc)
Bore and Stroke	2.71 x 1.97 in (69 x 50 mm)
Compression Ratio	8.5:1
Ignition System	Transistorized magneto
Maximum Horsepower	6.5 bhp (4.8 kW) at 3,600 rpm
Maximum Torque	9.74 ft-lb (13.2 N•m) at 2,500 rpm

### Transmission Design and Performance

Transmission Type	3 speed, manual shift
Mower Ground Speed (with engine at 3,100 rpm)	<b>1st:</b> 1.8 mph (2.9 km/h), <b>2nd:</b> 2.7 mph (4.3 km/h), <b>3rd:</b> 3.4 mph (5.4 km/h)



# TECHNICAL & CONSUMER INFORMATION

## Maintenance

Fuel	Unleaded gasoline with a pump octane rating of 86 or higher.	page 43
Engine Oil	SAE 10W-30, API SH or SJ	page 33
Spark Plug Type	<b>Regular:</b> NGK BP6ES DENSO W20EP-U <b>Resistor:</b> NGK BPR6ES DENSO W20EPR-U	page 36
Maximum Governed Speed	2,950 ~ 3,100 rpm	Shop manual
Flywheel Brake Cable	Adjust for 3/16~3/8 in (5~10) free play at flywheel brake lever.	page 39
Drive Clutch Cable	Adjust for 1/16~3/16 in (1~5 mm) free play at drive clutch lever.	page 40
Shift Cable	Adjust for proper shift lever operation.	page 41
Throttle Cable	Adjust for clearance on control arm.	page 42
Blade Bolt Torque	36~43 ft-lb (49~59 N•m)	page 31

## Tuneup

Spark Plug Gap	0.028 ~ 0.031 in (0.7 ~ 0.8 mm)	page 36
Idle Speed (throttle lever at SLOW)	1,700 ± 150 rpm	Shop manual
Valve Clearance (cold)	Intake 0.15 ± 0.04 mm Exhaust: 0.20 ± 0.04 mm	Shop manual
Other Specifications	No other adjustments needed.	

## CONSUMER INFORMATION

### Dealer Locator Information

To find an Authorized Honda Servicing Dealer anywhere in the United States:

Call (800) 426-7701

or visit our website:

[www.hondapowerequipment.com](http://www.hondapowerequipment.com)

### Customer Service

See page 70.

### Honda Publications

These publications will give you additional information for maintaining and repairing your lawn mower. You may order them from an authorized Honda servicing dealer.

#### ***Shop Manual***

This manual covers complete maintenance and overhaul procedures. It is intended to be used by a skilled technician.

#### ***Parts Catalog***

This manual provides complete, illustrated parts lists.

# TECHNICAL & CONSUMER INFORMATION

## Replacement Parts, Optional Equipment, and Service Items

Contact an authorized Honda servicing dealer to purchase any of these (or other) genuine, original Honda items for your lawn mower.

### Replacement Parts

Item	Part Number	Notes
Spark plug	98079-56846	NGK (brand) BPR6ES
Air filter	17211-ZL8-003	Paper filter
Mulching plug	76266-VE2-000ZA	
Upper blade	72531-VE2-020	A torque wrench is required to install blades.
Lower blade	72511-VE1-020	
Grass bag	81320-VE1-T00	Fabric bag only, no frame
Front wheel/tire	44710-VE1-E00	
Rear wheel/tire	42710-VG3-B00	

### Optional Equipment

Item	Part Number	Notes
Side discharge chute	06814-VE2-010	Use in place of grass bag
Deck guards	06761-VE2-000	Stainless steel guards protect sides of mower deck—drilling required
Leaf shredder	81510-VE2-000	Use with grass bag
Spark arrester parts	18350-ZL8-000	Arrester and deflector
	18356-ZL8-000	ID Plate
	90055-ZE1-000	Screw (two required)

### Service Items

Item	Part Number	Notes
SAE 10W-30 engine oil	08207-10W30	
Silicone spray	08209-0001	Lubricates control cable cores
Fuel stabilizer	08732-0001	For long term storage
Matte black touch-up paint (aerosol can)	08707-NH105	For handlebar only

# TECHNICAL & CONSUMER INFORMATION

## Distributor's Limited Warranty

PRODUCTS COVERED BY THIS WARRANTY	LENGTH OF WARRANTY (from date of original retail purchase)	
	Noncommercial/Nonrental	Commercial/Rental
Harmony Lawn Mower	24 months	3 months
Harmony Xenoy® Mower Deck	60 months	3 months
Parts & Accessories	See your authorized Honda servicing dealer for details	

### **To Qualify for this Warranty:**

The product must be purchased in the United States, Puerto Rico, or the U.S. Virgin Islands from American Honda or a dealer authorized by American Honda to sell those products. This warranty applies to the first retail purchaser and each subsequent owner during the applicable warranty time period.

### **What American Honda will Repair or Replace Under Warranty:**

American Honda will repair or replace, at its option, any part that is proven to be defective in material or workmanship under normal use during the applicable warranty time period. Warranty repairs and replacements will be made without charge for parts or labor. Anything replaced under warranty becomes the property of American Honda Motor Company, Inc. All parts replaced under warranty will be considered as part of the original product and any warranty on those parts will expire coincident with the original product warranty.

### **To Obtain Warranty Service:**

You must take the Honda Harmony lawn mower and proof of original retail purchase date, at your expense, to any Honda Power Equipment dealer in the United States, Puerto Rico, or the U.S. Virgin Islands who is authorized to service that product, during the dealer's normal business hours. If you are unable to obtain warranty service, or are dissatisfied with the warranty service you receive, take the following steps: First, contact the owner of the dealership involved; normally this should resolve the problem. However, if you should require further assistance, write or call the Power Equipment Customer Relations Department of American Honda Motor Co., Inc. Refer to page 70 for contact information.

### **Exclusions:**

THIS WARRANTY DOES NOT EXTEND TO PARTS AFFECTED OR DAMAGED BY ACCIDENT AND/OR COLLISION, NORMAL WEAR, FUEL CONTAMINATION, USE IN AN APPLICATION FOR WHICH THE PRODUCT WAS NOT DESIGNED, OR ANY OTHER MISUSE, NEGLIGENCE, INCORPORATION OR USE OF UNSUITABLE ATTACHMENTS OR PARTS, UNAUTHORIZED ALTERATION, OR ANY CAUSES OTHER THAN DEFECTS IN MATERIAL OR WORKMANSHIP OF THE PRODUCT.

MOWER BLADES AND MOWER DECK HOUSINGS, ARE SPECIFICALLY NOT WARRANTED AGAINST DAMAGE, INCLUDING BUT NOT LIMITED TO, ABRASIVE DAMAGE.

### **Disclaimer of Consequential Damage and Limitation of Implied Warranties:**

AMERICAN HONDA DISCLAIMS ANY RESPONSIBILITY FOR LOSS OF TIME OR USE OF THE PRODUCT, TRANSPORTATION, COMMERCIAL LOSS, OR ANY OTHER INCIDENTAL OR CONSEQUENTIAL DAMAGE. ANY IMPLIED WARRANTIES ARE LIMITED TO THE DURATION OF THIS WRITTEN LIMITED WARRANTY. Some states do not allow limitations on how long an implied warranty lasts and/or do not allow the exclusion or limitation of incidental or consequential damages, so the above exclusions and limitations may not apply to you. This warranty gives you specific legal rights, and you may also have other rights which vary from state to state.

## Emission Control System Warranty

Your new Honda Power Equipment engine complies with both the U.S. EPA and State of California emission regulations. American Honda provides the same emission warranty coverage for engines sold in all 50 states.

### **Your Warranty Rights And Obligations:**

#### **California**

The California Air Resources Board and American Honda Motor Co., Inc. are pleased to explain the emission control system warranty on your Honda Power Equipment engine. In California, new utility and lawn and garden equipment engines must be designed, built and equipped to meet the State's stringent anti-smog standards.

#### **Other States**

In other areas of the United States your engine must be designed, built, and equipped to meet the U.S. EPA emission standards for spark-ignited engines at or below 19 kilowatts.

#### **All States**

American Honda Motor Co., Inc. must warrant the emission control system on your power equipment engine for the period of time listed below provided there has been no abuse, neglect or improper maintenance of your power equipment engine. Where a warrantable condition exists, American Honda Motor Co., Inc. will repair your power equipment engine at no cost to you including diagnosis, parts and labor.

Your emission control system may include such parts as the carburetor or fuel injection system, the ignition system, and catalytic converter. Also included may be hoses, connectors and other emission-related assemblies.

### **Manufacturer's Warranty Coverage:**

The 1995 and later power equipment engines are warranted for two years. If any emission-related part on your engine is defective, the part will be repaired or replaced by American Honda Motor Co., Inc.

### **Owner's Warranty Responsibility:**

As the power equipment engine owner, you are responsible for the performance of the required maintenance listed in your owner's manual. American Honda Motor Co., Inc. recommends that you retain all receipts covering maintenance on your power equipment engine, but American Honda Motor Co., Inc. cannot deny warranty coverage solely for the lack of receipts or for your failure to ensure the performance of all scheduled maintenance.

As the power equipment engine owner, you should however be aware that American Honda Motor Co., Inc. may deny you warranty coverage if your power equipment engine or a part has failed due to abuse, neglect, improper maintenance, or unapproved modifications.

You are responsible for presenting your power equipment engine to a Honda Power Equipment dealer as soon as a problem exists. The warranty repairs should be completed in a reasonable amount of time, not to exceed 30 days.

If you have any questions regarding your warranty rights and responsibilities, you should write or call the Honda Power Equipment Customer Relations Department. Refer to page 70 for contact information.

## TECHNICAL & CONSUMER INFORMATION

---

### ***Warranty Coverage:***

Honda power equipment engines manufactured after January 1, 1995 and sold in the State of California, and U.S. EPA certified engines manufactured on or after September 1, 1996 and sold in all of the United States, are covered by this warranty for a period of two years from the date of delivery to the original retail purchaser. This warranty is transferable to each subsequent purchaser for the duration of the warranty period.

Warranty repairs will be made without charge for diagnosis, parts or labor. All defective parts replaced under this warranty become the property of American Honda Motor Co., Inc. A list of warranted parts is on the reverse side of this warranty statement. Normal maintenance items, such as spark plugs and filters, that are on the warranted parts list are warranted up to their required replacement interval only.

American Honda Motor Co., Inc. is also liable for damages to other engine components caused by a failure of any warranted part during the warranty period.

Only Honda approved replacement parts may be used in the performance of any warranty repairs and must be provided without charge to the owner. The use of replacement parts not equivalent to the original parts may impair the effectiveness of your engine emission control system. If such a replacement part is used in the repair or maintenance of your engine, and an authorized Honda dealer determines it is defective or causes a failure of a warranted part, your claim for repair of your engine may be denied. If the part in question is not related to the reason your engine requires repair, your claim will not be denied.

### ***To Obtain Warranty Service:***

You must take your Honda Power Equipment engine or the product on which it is installed, along with your warranty registration card or other proof of original purchase date, at your expense, to any Honda Power Equipment dealer who is authorized by American Honda Motor Co., Inc. to sell and service that Honda product during his normal business hours. Claims for repair or adjustment found to be caused solely by defects in material or workmanship will not be denied because the engine was not properly maintained and used.

If you are unable to obtain warranty service, or are dissatisfied with the warranty service you received, contact the owner of the dealership involved. Normally this should resolve your problem. However, if you require further assistance, write or call the Power Equipment Customer Relations Department of American Honda Motor Co., Inc. Refer to page 70 for contact information.

# TECHNICAL & CONSUMER INFORMATION

## **Exclusions:**

FAILURES OTHER THAN THOSE RESULTING FROM DEFECTS IN MATERIAL OR WORKMANSHIP ARE NOT COVERED BY THIS WARRANTY. THIS WARRANTY DOES NOT EXTEND TO EMISSION CONTROL SYSTEMS OR PARTS WHICH ARE AFFECTED OR DAMAGED BY OWNER ABUSE, NEGLIGENCE, IMPROPER MAINTENANCE, MISUSE, MISFUELING, IMPROPER STORAGE, ACCIDENT AND/OR COLLISION, THE INCORPORATION OF, OR ANY USE OF, ANY ADD-ON OR MODIFIED PARTS, UNSUITABLE ATTACHMENTS, OR THE UNAUTHORIZED ALTERATION OF ANY PART.

THIS WARRANTY DOES NOT COVER REPLACEMENT OF EXPENDABLE MAINTENANCE ITEMS MADE IN CONNECTION WITH REQUIRED MAINTENANCE SERVICES AFTER THE ITEM'S FIRST SCHEDULED REPLACEMENT AS LISTED IN THE MAINTENANCE SECTION OF THE PRODUCT OWNER'S MANUAL, SUCH AS: SPARK PLUGS AND FILTERS.

## **Disclaimer of Consequential Damage and Limitation of Implied Warranties:**

AMERICAN HONDA MOTOR CO., INC. DISCLAIMS ANY RESPONSIBILITY FOR INCIDENTAL OR CONSEQUENTIAL DAMAGES SUCH AS LOSS OF TIME OR THE USE OF THE POWER EQUIPMENT, OR ANY COMMERCIAL LOSS DUE TO THE FAILURE OF THE EQUIPMENT; AND ANY IMPLIED WARRANTIES ARE LIMITED TO THE DURATION OF THIS WRITTEN WARRANTY. THIS WARRANTY IS APPLICABLE ONLY WHERE THE CALIFORNIA OR U.S. EPA EMISSION CONTROL SYSTEM WARRANTY REGULATION IS IN EFFECT.

## **Emission Control System Warranty Parts:**

<b>SYSTEMS COVERED BY THIS WARRANTY</b>	<b>PARTS DESCRIPTION</b>
Fuel Metering	Carburetor assembly, Fuel injection pump, Fuel injection nozzle, fuel regulator
Exhaust System	Catalyst
Air Induction	Air filter housing, Air filter element*, Crankcase breather tube
Ignition	Flywheel magneto, Ignition pulse generator, Ignition coil assembly, Ignition control module, Spark plug cap, Spark plug*
Miscellaneous Parts	Tubing, fittings, seals, gaskets, and clamps associated with these listed systems.
* Covered up to the first required replacement only. See the <i>Maintenance Schedule</i> on page 28.	

## **TECHNICAL & CONSUMER INFORMATION**

---

### **Customer Service Information**

Honda Power Equipment dealership personnel are trained professionals. They should be able to answer any question you may have. If you encounter a problem that your dealer does not solve to your satisfaction, please discuss it with the dealership's management. The Service Manager or General Manager can help. Almost all problems are solved in this way.

If you are dissatisfied with the decision made by the dealership's management, contact the Honda Power Equipment Customer Relations Office. You can write:

American Honda Motor Co., Inc.  
Power Equipment Division  
Customer Relations Office  
4900 Marconi Drive  
Alpharetta, GA 30005-8847

Or telephone: (770) 497-6400 M-F, 8:30 a.m. - 7:00 p.m.

When you write or call, please give us this information:

- Model and serial numbers (page 58)
- Name of the dealer who sold the lawn mower to you
- Name and address of the dealer who services your lawn mower
- Date of purchase
- Your name, address, and telephone number
- A detailed description of the problem



## A

- Accessories. *See Parts*
- Air Cleaner Service ..... 35
- Air Filter Part Number ..... 65
- Air Index ..... 61
- Altitude, High Altitude Operation ..... 57

## B

- Bag. *See Grass Bag*
- Before Operation ..... 11
- Blade
  - Inspection ..... 29
  - Installation ..... 31
  - Part Numbers ..... 65

## C

- Cable Adjustments
  - Drive Clutch Cable ..... 40
  - Flywheel Brake Cable ..... 39
  - Shift Cable ..... 41
- Capacities ..... 62
- Carburetor
  - Draining ..... 48
  - High Altitude Notes ..... 57
- Choke ..... 16
- Cleaning, Before Storage ..... 45
- Clogged Mower Deck ..... 24
- Controls & Features ..... 7
- Customer Relations ..... 70
- Cutting Height
  - Adjustment Levers ..... 10, 15
  - Recommendations ..... 23
- Cutting Height Adjustment ..... 15
- Cutting Width ..... 23

## D

- Dimensions ..... 62
- Drive Clutch Lever
  - Cable Adjustment ..... 40
  - Operation ..... 19

## E

- Emission Control System ..... 59
- Ethanol. *See Fuel, Oxygenated Fuels*

## F

- Filter. *See Air Cleaner Service*
- Flywheel Brake Lever
  - Cable Adjustment ..... 39
  - Operation ..... 9
- Fuel
  - Additive ..... 47
  - Capacity ..... 62
  - Oxygenated Fuels ..... 58
  - Tank Draining ..... 48
  - Valve ..... 8

## G

- Grass Bag
  - Capacity ..... 62
  - Cleaning ..... 32
  - Inspection ..... 14
  - Part Numbers ..... 65
  - Removal and Installation ..... 14
  - Replacement ..... 32

## H

- Handlebar
  - Folding ..... 49
  - Height Adjustment ..... 13

## L

- Leaf Shredder, Part Number ..... 65
- Leaves, Bagging ..... 24
- Loading ..... 51

## M

- Maintenance Schedule ..... 28
- Methanol. *See Fuel, Oxygenated Fuels*
- Mower Deck Clogging ..... 24
- Mowing Tips ..... 23
- MTBE. *See Fuel, Oxygenated Fuels*
- Mulching Plug
  - Part Number ..... 65
  - Usage ..... 13

## N

- NOTICE symbol ..... 1

# INDEX

---

## O

Oil	
Capacity .....	62
Change .....	34
Level Check .....	33
Part Number .....	65
Recommended .....	33

## P

Paint, Part Number .....	65
Parts, Replacement & Optional .....	65
Publications .....	64

## S

Safety	
A few words .....	2
Information .....	4
Label Locations .....	6
Message Definitions .....	2
Safe Mowing Practices .....	21
Set-Up Instructions .....	54
Shift Lever	
Cable Adjustment .....	41
Operation .....	19
Side-Discharge Chute, Part Number	65
Spark Arrester	
Part Numbers .....	65
Service .....	38
Spark Plug	
Part Number .....	65
Service .....	36
SPECIFICATIONS .....	62
Specifications	
Dimensions .....	62
Engine .....	62
Maintenance .....	63
Tuneup .....	63
Speed, Ground Speeds .....	62
Starting the Engine .....	16
Stopping the Engine .....	20
Storage	
Placing in Storage .....	50
Preparation .....	45
Removing from Storage .....	50

## T

Throttle Lever	
Cable Inspection .....	42
Operation .....	18
Troubleshooting	
Engine .....	52
Mowing and Bagging .....	53
Vibration .....	53
Tuneup Specifications .....	63

## U

Unloading .....	51
-----------------	----

## V

Valve Clearance .....	63
-----------------------	----

## W

Warnings. <i>See Safety Message</i>	
Definitions	
Warranty	
for Emission Control System .....	67
for Lawn Mower .....	66
for Xenoy Mower Deck .....	66
Getting Service .....	70
Washing	
Grass Bag .....	32
Mower .....	45
Weights .....	62

# QUICK REFERENCE INFORMATION

Fuel	Type	Unleaded gasoline with a pump octane rating of 86 or higher (page 43)
	Capacity	0.29 US gal (1.1ℓ)
Engine oil	Type	SAE 10W-30, API SH or SJ (page 33)
	Capacity	.58 US qt (0.55 ℓ)
Spark plug	Type	Regular: NGK BP6ES DENSO W20EP-U  Resistor: NGK BPR6ES DENSO: W20EPR-U
	Electrode gap	0.028 – 0.031 in (0.70 – 0.80 mm)
Carburetor	Idle speed	1,700 ± 150 rpm
Maintenance	Before each use	Check engine oil (page 33) Check air cleaner (page 35)
	First 5 hours	Change engine oil (page 34)
	Subsequent	Refer to the Maintenance Schedule (page 28)

# **HONDA**

The power of dreams.™

31VE1300  
00X31-VE1-3000



Printed on  
Recycled Paper



POM53538

IPC 20000.2002.11  
PRINTED IN U.S.A.