

HONDA

Power

Equipment

OPERATOR'S MANUAL

GB4500 GRASS-BAGGING KIT

and

BK4542/BK4546 SIDE-BLOWER KIT

installed on

CD4542/CD4542C/CD4546C MOWER DECKS

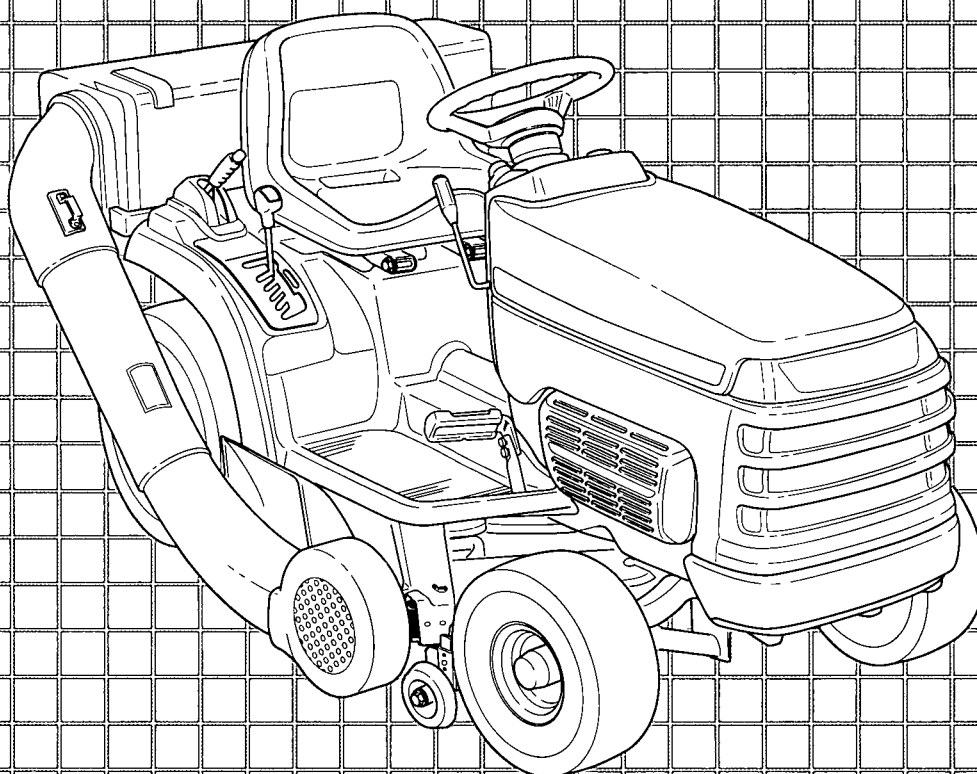

HONDA DEALER: PLEASE GIVE THIS PUBLICATION TO YOUR CUSTOMER

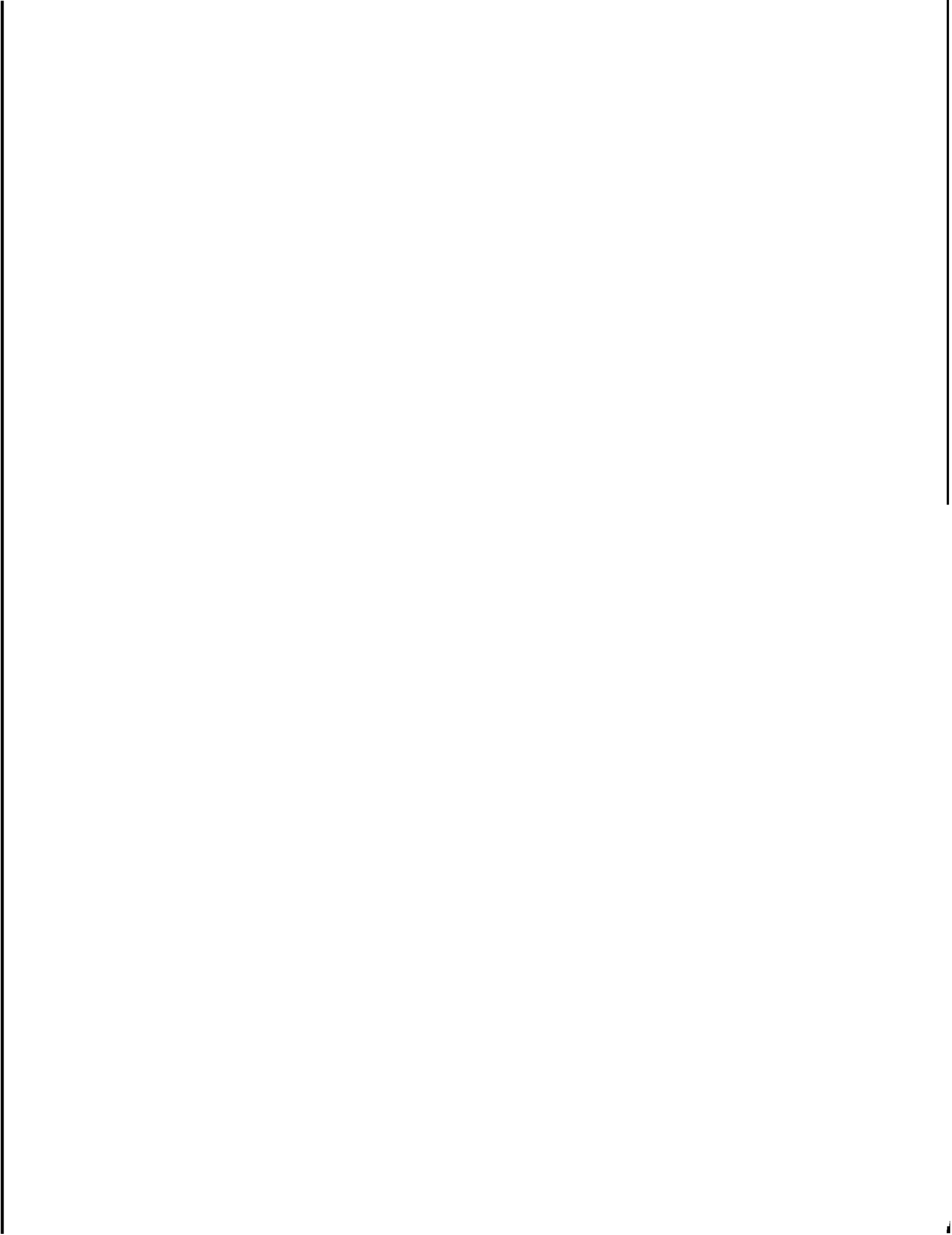

The information in this operator's manual is limited in application to the Honda GB4500 grass-bagging kit and BK4542 or BK4546 side-blower kit installed on Honda CD4542, CD4542C, or CD4546C mower decks. Before operating this equipment, read this manual and the owner's manual supplied with your Honda lawn tractor.

All information in this publication is based on the latest product information available at the time of printing. Honda Power Equipment Mfg., Inc. reserves the right to make changes at any time without notice and without incurring any obligation.

No part of this publication may be reproduced without written permission.

This manual is a permanent part of the mower deck and lawn tractor, and it must stay with them if they are resold.

READ THIS OPERATOR'S MANUAL CAREFULLY. Pay special attention to these symbols and any instructions that follow:

⚠ DANGER You WILL be KILLED or SERIOUSLY HURT if you don't follow instructions.

⚠ WARNING You CAN be KILLED or SERIOUSLY HURT if you don't follow instructions.

⚠ CAUTION You CAN be HURT if you don't follow instructions.

NOTICE Your equipment or other property can be damaged if you don't follow instructions.

Honda side-blower and grass-bagging kits are designed to give safe and dependable service if operated according to instructions. Operating this equipment requires special effort on your part to ensure your safety and the safety of others.

⚠ WARNING Careless operation or misuse can cause injury or property damage. Read and understand this owner's manual before operating this equipment.

If a problem should arise, or if you have any questions about your equipment, see an authorized Honda lawn tractor dealer.

1. SAFETY

Read all safety instructions before operating the equipment.

⚠ WARNING

OBJECTS MAY BE THROWN FROM MOWER.
DO NOT OPERATE MOWER UNLESS
GRASS CATCHER IS ATTACHED.

⚠ WARNING

TO AVOID TIP-OVER OF THE MOWER.
■ DO NOT CARRY ANY PASSENGERS OR
CARGO ON THIS COVER

⚠ WARNING

DRIVE BELT AND PULLEYS CAN INJURE YOU.
PUT GUARD IN PLACE BEFORE OPERATION.

⚠ WARNING

OBJECTS MAY BE THROWN FROM MOWER.
■ SHUT OFF ENGINE BEFORE REMOVING OR
INSTALLING BAG AND CHUTE.
■ DO NOT OPEN HOPPER TOP WHILE BLADE IS
TURNING.
■ OPERATE MOWER WITH COMPLETE BAGGING
ATTACHMENT IN PLACE.

⚠ CAUTION

UNDER NORMAL USAGE, THIS BAG MATERIAL
IS SUBJECT TO DETERIORATION AND WEAR,
AND SHOULD BE CHECKED FREQUENTLY FOR
BAG REPLACEMENT. THIS BAG CONFORMS
TO A.N.S.I. STANDARD B71.1. ANY REPLACEMENT
MUST MEET THIS STANDARD.

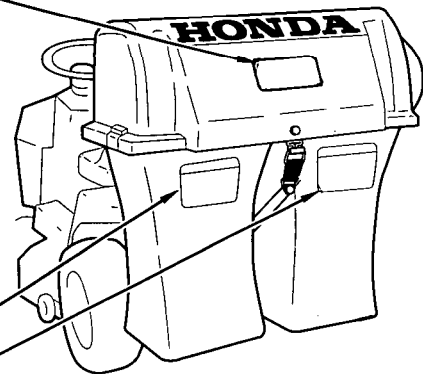
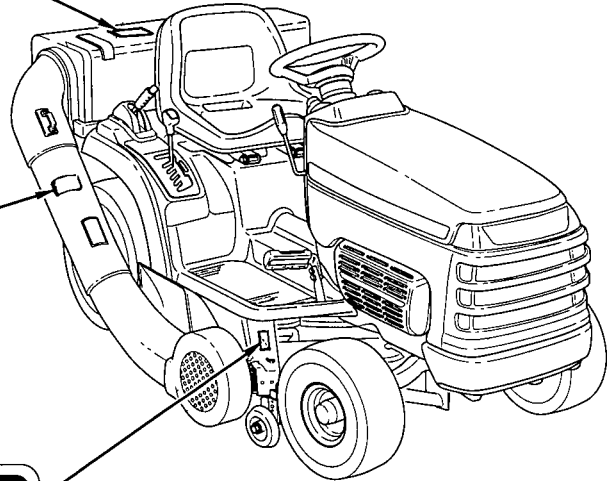

SAFETY INFORMATION

For your safety and the safety of others, pay special attention to these precautions:

Operator Responsibility

- Keep the tractor in good operating condition. Operating a tractor in poor or questionable condition could result in serious injury.
- Be sure all safety devices are in working order and warning labels are in place. These items are installed for your safety.
- Know how to stop the engine and attachments quickly in case of emergency. Understand the use of all controls.
- Be sure that anyone who operates the tractor receives proper instruction. Allowing anyone, especially children, to operate the tractor without proper instruction may result in injury.
- Allowing passengers to ride on the tractor or any of its attachments may cause the tractor to tip over.
- Full grass bags may unbalance the tractor on steep hills. Before going up a hill, make sure the grass bags are no more than half full.
- Wear sturdy, full coverage footwear. Operating the tractor barefoot, or with open-toe shoes or sandals increases your risk of injury.
- Dress sensibly. Loose clothing may get caught in moving parts, increasing your risk of injury.
- The blower drive belt and pulleys can injure you. Be sure the blower belt cover is in place before operating the tractor.
- Be alert. Operating the tractor when you are tired, ill, or under the influence of alcohol or drugs may result in serious injury.
- Keep all persons and pets away from the operating area.

Child Safety

Serious injury or death can occur if a child falls off the tractor or runs into the tractor's path and is run over by the machine.

- Allowing children to ride as passengers on the tractor can be dangerous.
- Never assume that children will remain where you last saw them. Be alert, and turn the machine off if children enter the area. Use extreme care when backing up, and when approaching corners, shrubs, trees, and other obstructions that might hide a child from sight.

1. SAFETY

Blade Hazards

The blades are sharp and turn at high speed. Accidental contact can cause serious injury.

- Keep hands and feet away from the mower deck while the engine is running.
- Disengage the Power Take Off (P.T.O.), and stop the engine, before performing any inspection or maintenance.
- Wear heavy gloves to protect your hands from the blades when cleaning out the mower deck, or when inspecting or replacing the blades.

Thrown Object Hazards

Objects hit by the blades can be thrown with great force. Thrown objects may cause serious injury or property damage.

- Before mowing, clear the lawn of sticks, stones, dog bones, and other litter and loose objects. Mow only in daylight, or in well-lit areas at night, so you can see and avoid objects in the grass.
- Before operating the tractor, be sure the hopper top, grass bags, and grass bag chutes are in place, or that the side-discharge chute is down.
- Disengage the Power Take Off (P.T.O.), and shut off the engine, before opening the hopper top, or removing and installing grass bags and chutes.
- Disengage the Power Take Off (P.T.O.) to stop the blades before crossing a gravel driveway or any other area with loose stones.
- Broken pieces thrown from worn or damaged blades can cause serious injury. Always inspect the blades before using the tractor.
- Always inspect the mower deck and blades for damage after striking a foreign object. Repair or replace any damaged parts before continued use. Always replace bent blades; do not attempt to straighten them.

Fire Hazards

Dry grass and leaves are flammable.

- An accumulation of dry grass and leaves around the engine, the exhaust system, or on top of the mower deck (especially around the pulleys) may ignite.
- Always empty the grass bags when you finish mowing, even if they are not full. Stored lawn clippings are a fire hazard.

IMPORTANT MESSAGE TO PARENTS

YOUR CHILDREN'S SAFETY **IS** VERY IMPORTANT to Honda. That's why we urge you to read this message before letting your youngster operate a lawn tractor and mowing equipment. Lawn tractors and mowing equipment are tools, not toys. As with any equipment, bad judgments can result in serious injuries. You can help prevent accidents by making good decisions about **if**, **when**, and **how** your youngster operates this equipment.

The first question you'll need to ask is whether your youngster is capable of operating this equipment safely. Remember, young people vary widely, and **AGE IS NOT THE ONLY FACTOR**.

Physically, a youngster must be **LARGE ENOUGH AND STRONG ENOUGH** to easily control the tractor's direction. The youngster also needs enough size, strength, and coordination to comfortably reach and operate the controls.

Another tougher question you need to ask is if your youngster has enough **MATURITY AND RESPONSIBILITY** to safely operate this equipment. Does the young person think through problems and come to logical solutions? Be honest! Anyone who takes unnecessary risks and doesn't obey rules should not operate this equipment.

If you decide that your son or daughter can handle this equipment safely, **CAREFULLY READ THE OWNER'S MANUALS** with your youngster; read the owner's manual supplied with your Honda lawn tractor in addition to this one. Make sure you both understand all instructions and warnings. Also, be sure your youngster wears sturdy shoes and other protective clothing when operating this equipment.

SUPERVISION is **also** very important. Closely supervise your youngster during the first few minutes of mowing. Even after the youngster has become confident with the mower, do not let the young person use this equipment without good adult supervision. An adult should also be present during refueling and maintenance. In fact, it's up to parents to make sure that all equipment is properly maintained and kept in safe operating condition.

By always placing safety first, your youngster will acquire useful skills and a sense of accomplishment. And you'll both get the best results from your equipment.

2. SERVICE

GRASS BAG REMOVAL AND INSTALLATION

⚠WARNING Objects thrown by the blades can cause serious injury. Disengage the Power Take Off (P.T.O.), and shut off the engine, before opening the hopper top and removing the grass bags. Replace worn or damaged grass bags.

Removal

1. Unhook the retaining band from the hopper top.
2. Open the hopper top, and remove the grass bags.

Installation

1. Hook the bags onto the retaining lugs of the bag supports.
2. Close the hopper top, and secure it with the retaining band.

NOTE:

- Retaining band tension is adjustable. To adjust, loosen the 6 mm flange bolt at the base of the retaining band, and move the band up or down. Tighten the 6 mm flange bolt to a torque value of 8.0 ft-lb (1.1 kg-m).
- Under normal mowing conditions, the left grass bag will fill first, then the right bag will fill.
- Empty the grass bags before they both become filled to capacity. If the bags become overfilled, grass may clog the chute.
- Grass bags will not collect grass efficiently if clogged with dirt. Wash dirty bags with a garden hose, and allow them to dry completely before use; wet bags will clog quickly.
- **Do not** line the grass bags with plastic trash bags. Any material that interferes with air flow through the grass bags will reduce bagging performance.

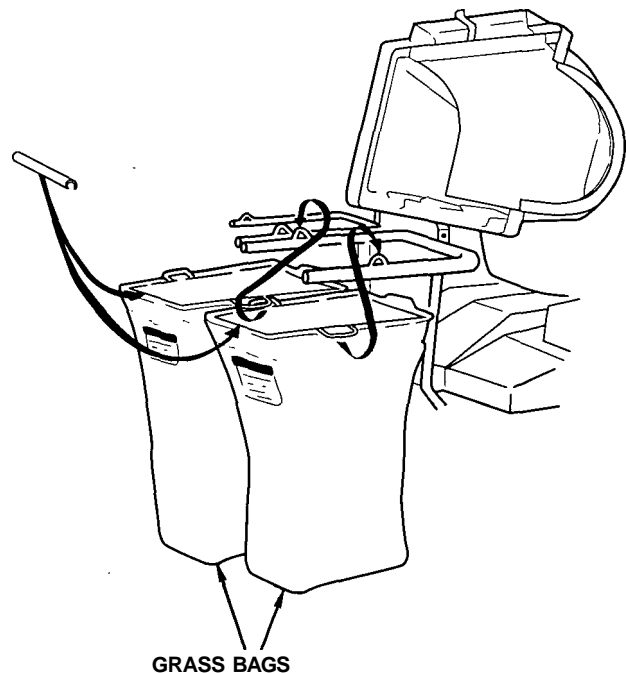
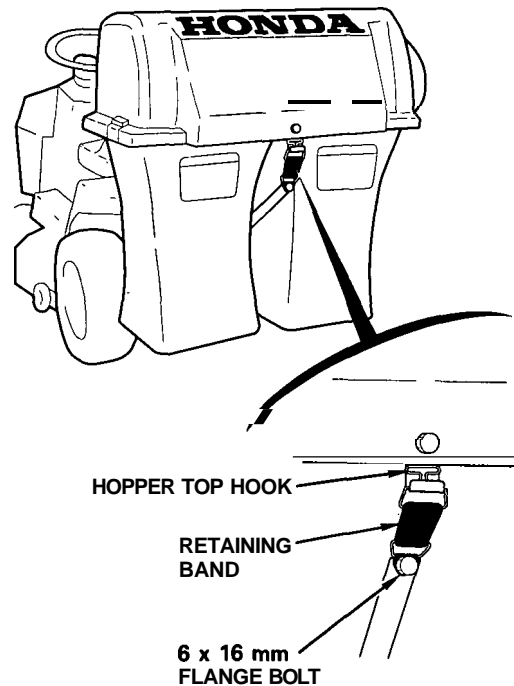

CHUTE DISCONNECTION AND REMOVAL FOR CLEANING

⚠WARNING Objects thrown by the blades can cause serious injury. Disengage the Power Take Off (P.T.O.), and shut off the engine, before disconnecting the chute sections.

Removal

1. Grasp the upper chute by the chute handle. Raise the upper chute to pull the middle chute off the lower chute.
2. Remove the chute pin to remove the lower chute from the mower deck.

Installation

1. Hook the rear edge of the lower chute onto the mower deck, align the front pin holder brackets, and insert the chute pin.
2. Grasp the upper chute by the chute handle. Raise the upper and middle chutes, then slide the middle chute over the lower chute.

The window in the middle chute allows you to verify that the grass clippings are moving freely into the bags. If you see the flow stop, that indicates clogging.

If clogging occurs, disengage the Power Take Off (P.T.O.), shut off the engine, then disconnect the chute sections and use a stick to unclog them. It may not be necessary to remove the lower chute to unclog it.

Clean the inner surfaces of the chute sections and hopper top periodically. This will help to keep the grass clippings moving freely into the bags.

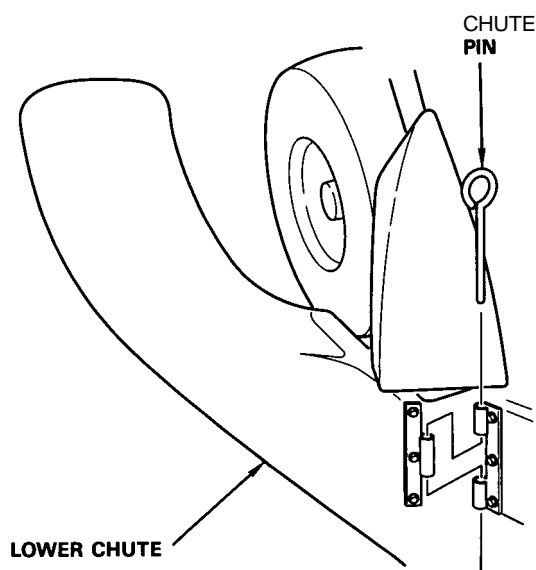
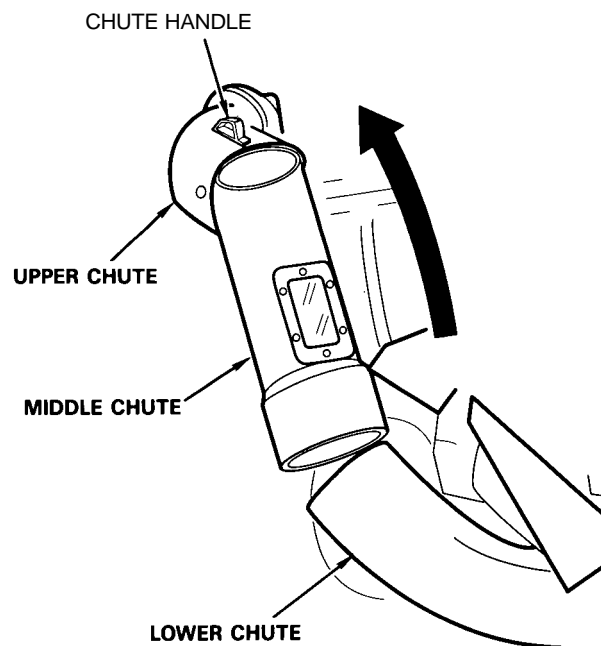

2. SERVICE

DRIVE BELT REPLACEMENT

⚠ WARNING Contact with moving belts and pulleys can cause serious injury. Disengage the Power Take Off (P.T.O.), and shut off the engine, before removing the belt cover and cover plate.

Removal

1. Lower the mower deck as far as it will go.
2. Remove the three 1/4 inch wing nuts and washers from the belt cover. Remove the belt cover.

NOTE: There are two additional 1/4 inch washers below the rear belt cover mounting holes. Be careful not to lose any of the washers.

3. Remove the two 6 x 12 mm flange bolts from the cover plate on the blower assembly. Remove the cover plate.
4. Unhook the blower drive belt from the mower deck pulley, then remove it from the blower assembly.

NOTE: Observe the installed position of the blower drive belt, so you will be sure to replace it correctly. If the belt is reversed on the mower deck pulley during replacement, the blower will run backwards.

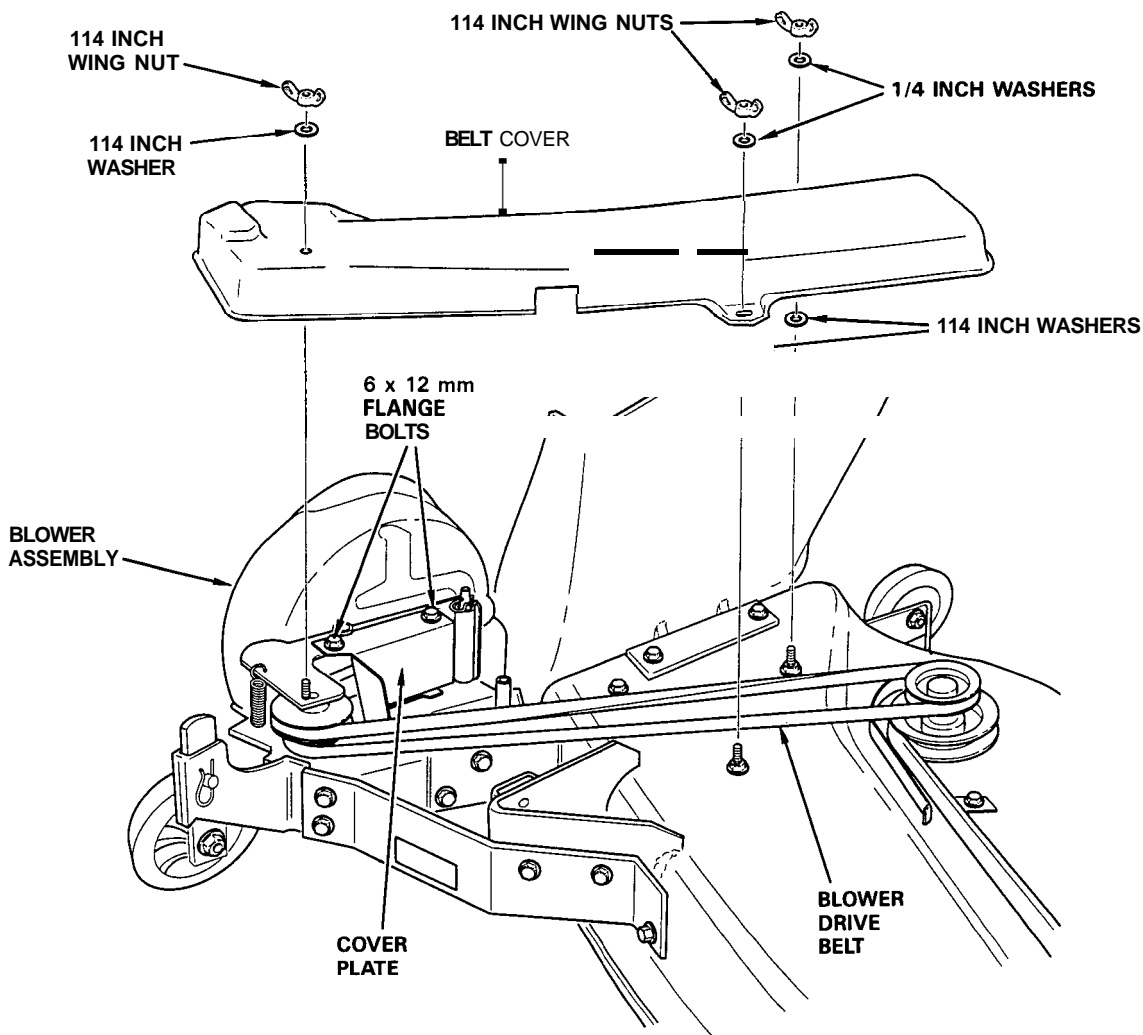

DRIVE BELT REPLACEMENT (continued)

Installation

1. Install the replacement belt on the blower pulleys, then hook it onto the mower deck pulley.

It is important to install the belt correctly; if the belt is reversed on the mower deck pulley, the blower will run backwards.

The belt runs from the upper blower pulley to the outer side of the mower deck pulley (the side toward the discharge chute). The belt returns from the inner side of the mower deck pulley (the side toward the middle of the mower deck) to the lower blower pulley. Refer to the illustration on page 8.

2. Install the cover plate on the blower assembly. Tighten the two 6 x 12 mm flange bolts to a torque value of 8.0 ft-lb (1.1 kg-m).
3. Install the belt cover, washers, and wing nuts. Refer to the illustration on page 8. Tighten the wing nuts securely.

SIDE-DISCHARGE MOWING

The grass bags, hopper, bag chutes, and blower can be removed for side-discharge mowing. This permits the side-discharge chute to swing down to its operating position.

⚠ WARNING Objects thrown by the blades can cause serious injury. Before operating the tractor for side-discharge mowing, be sure the side-discharge chute is lowered.

BAG, HOPPER, CHUTE, AND BLOWER REMOVAL FOR SIDE-DISCHARGE MOWING

⚠ WARNING Objects thrown by the blades can cause serious injury. Disengage the Power Take Off (P.T.O.), and shut off the engine, before removing equipment.

Removal

1. Remove the grass bags (see page 6).
2. Lift the bag support assembly, with hopper top and chutes, off the left and right mounting struts.
3. Remove the lower chute (see page 7).

NOTE: For side-discharge mowing, you must also remove the blower (see page 10).

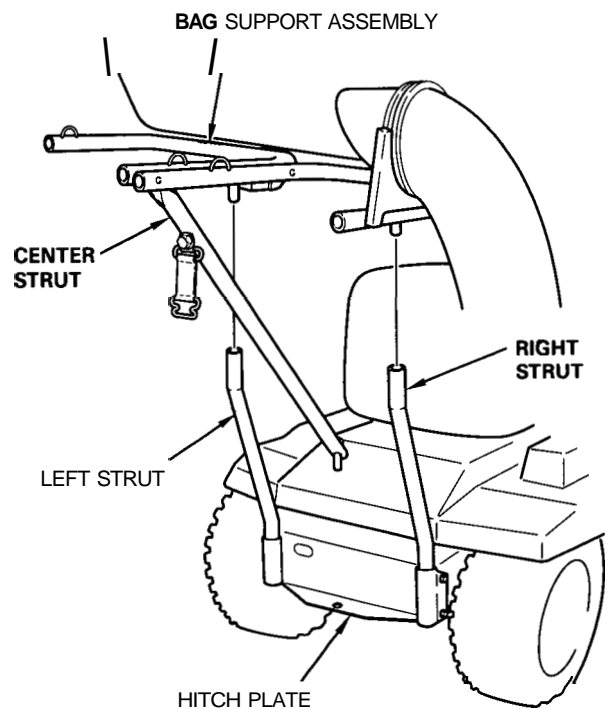

2. SERVICE

BAG, HOPPER, CHUTE, AND BLOWER REMOVAL FOR SIDE-DISCHARGE MOWING (continued)

Installation

Install in reverse order of removal.

When installing the bag support assembly on the left and right struts, insert the center strut pin in the tractor's hitch plate hole (see page 9).

Refer to page 7 for chute installation instructions.

BLOWER REMOVAL FOR SIDE-DISCHARGE MOWING

⚠ WARNING Objects thrown by the blades can cause serious injury. Disengage the Power Take Off (P.T.O.), and shut off the engine, before disconnecting the chute sections and removing the blower assembly.

Removal

NOTE: You must remove the lower chute (see page 7) before you can remove the blower. For side-discharge mowing, also remove the bag support assembly with hopper top, upper chute, and middle chute (see page 9).

1. Lower the mower deck as far as it will go.
2. Remove the blower drive belt from the mower deck pulley (see page 8).

NOTE: Leave the belt on the blower pulleys. Complete belt removal is not necessary for blower removal.

3. Remove the lock pin, and **lift** the blower assembly off its mounting bracket.

Installation

Install in reverse order of removal.

Refer to pages 8 and 9 for blower belt installation instructions.

Refer to page 7 for chute installation instructions.

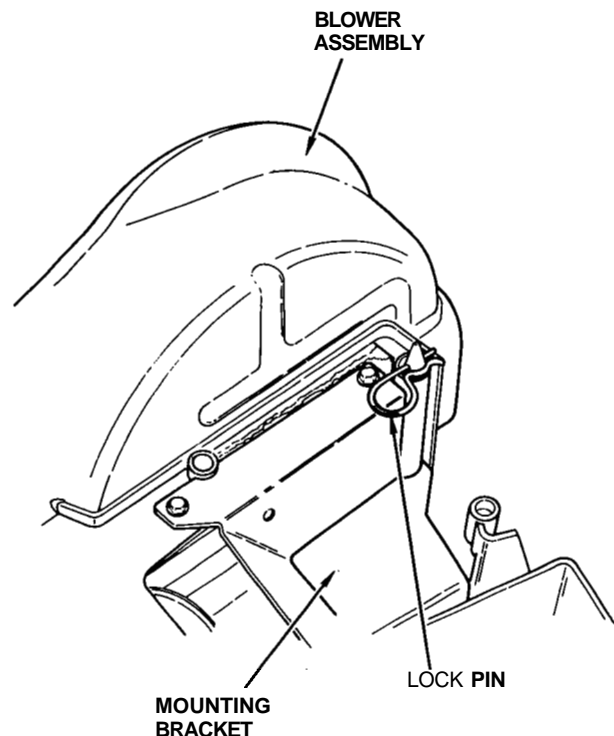

3. WARRANTY SERVICE

Owner Satisfaction

Your satisfaction and goodwill are important to your dealer and to us. All Honda warranty details are explained in the Distributor's Limited Warranty. Normally, any problems concerning the product will be handled by your dealer's service department. If you have a warranty problem that has not been handled to your satisfaction, we suggest you take the following action:

- Discuss your problem with a member of the dealership management. Often complaints can be quickly resolved at that level. If the problem has already been reviewed with the Service Manager, contact the Owner of the dealership or the General Manager.
- If your problem still has not been resolved to your satisfaction, contact the Power Equipment Customer Service Department of American Honda Motor Co., Inc.

American Honda Motor Co., Inc.
Power Equipment Division
P.O. Box 100021
Duluth, Georgia 30136-9421
Telephone: (404) 497-6400

We **will** need the following information in order to assist you:

- Your name, address, and telephone number
- Product model
- Date of purchase
- Dealer name and address
- Nature of problem

After reviewing all the facts involved, you will be advised of what action can be taken. Please bear in mind that your problem will likely be resolved at the dealership, using the dealer's facilities, equipment, and personnel, **so** it is very important that your initial contact be with the dealer.

Your purchase of a Honda product is greatly appreciated by both your dealer and American Honda Motor Co., Inc. We want to assist you in every way possible to assure your satisfaction with your purchase.

3752532

PMI 3500911
PRINTED IN U.S.A.