

HONDA

TILLER

F401/F501

OWNER'S MANUAL

Thank you for purchasing a Honda tiller.

This manual covers operation and maintenance of F401 and F501 tillers. All information in this publication is based on the latest product information available at the time of approval for printing.

Honda motor Co., Ltd. reserves the right to make changes at any time without notice and without incurring any obligation.

No part of this publication may be reproduced without written permission.

This manual should be considered a permanent part of the tiller and remain with the tiller when sold.

Pay special attention to statements preceded by the following words:

 **WARNING** Indicates a strong possibility of severe personal injury or death if instructions are not followed.

CAUTION: Indicates a possibility of personal injury or equipment damage if instructions are not followed.

NOTE: Gives helpful information.

If a problem should arise, or if you have any questions about the tiller, consult an authorized Honda dealer.

 **WARNING** Honda tillers will give safe and dependable service when operated according to instructions. Read and understand the Owner's Manual before operating the tiller. Failure to do so could result in personal injury or equipment damage.

IMPORTANT NOTICE

This tiller is not equipped with a spark arrester. Operation on forest, brush or grass covered land may be illegal in some states. Check local laws and regulations before operation.

CONTENTS

| | |
|-----------------------------------|----|
| 1. TILLER SAFETY | 3 |
| 2. COMPONENT IDENTIFICATION | 4 |
| 3. PRE-OPERATION CHECK | 5 |
| 4. STARTING THE ENGINE | 9 |
| 5. TILLER OPERATION | 11 |
| • High altitude operation | 13 |
| 6. STOPPING THE ENGINE | 14 |
| 7. MAINTENANCE | 15 |
| 8. TRANSPORTING/STORAGE | 22 |
| 9. TROUBLESHOOTING | 23 |
| 10. SPECIFICATIONS | 24 |
| 11. WARRANTY SERVICE | 25 |

1. TILLER SAFETY

WARNING

To ensure safe operation —

- Never permit anyone to operate the tiller without proper instruction.
- Know how to stop the tiller quickly and understand the operation of all the controls — **READ THIS OWNER'S MANUAL CAREFULLY.**
- Keep children and pets at a safe distance when tilling.
- Wear suitable clothing and shoes while using the tiller.
- Never operate the tiller without the V-belt cover or the recoil starter cover.
- Make sure that all fasteners are properly secured.
- When tilling on an incline, keep the fuel tank less than half full to minimize fuel spillage.
- Always stop the engine before cleaning the tines or making adjustments.
- Be very cautious when operating the tiller in REVERSE (A2 type), especially if attachments are being used.
- Keep a firm hold on the handlebars; they may tend to lift during clutch engagement.
- Clear the area to be tilled by picking up any stones, wire, glass, large sticks, metal, etc.
- If the tiller strikes an object while tilling, stop the engine and check for damage.
- Stop the engine whenever you leave the tiller. Never allow it to idle unattended.

2. COMPONENT IDENTIFICATION

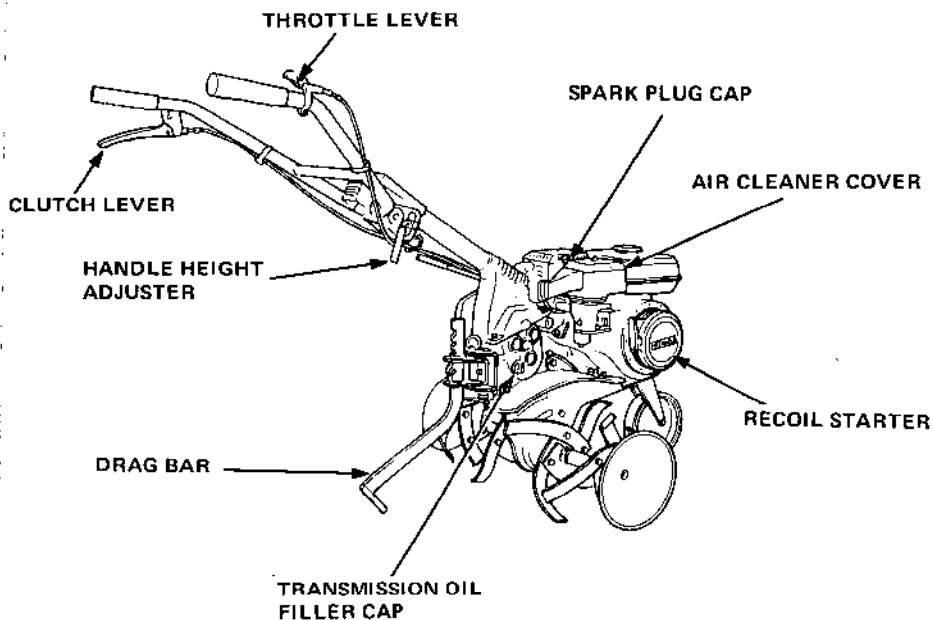
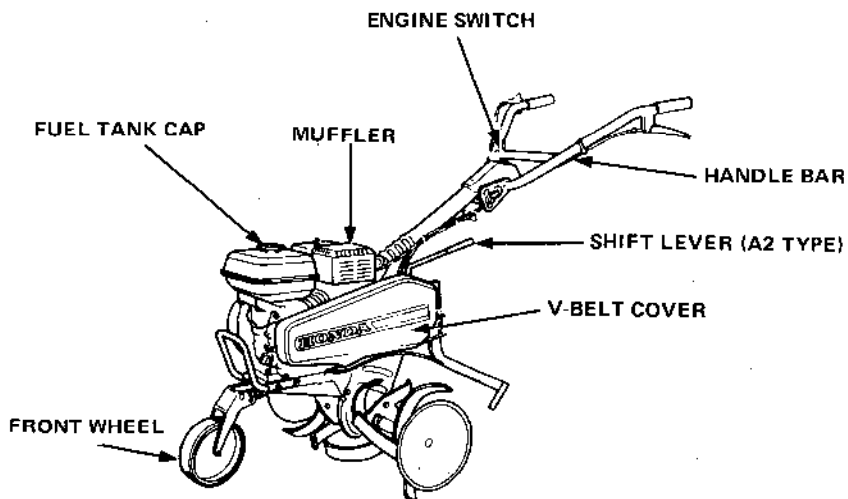

3. PRE-OPERATION CHECK

1. Engine oil level

CAUTION:

- Engine oil is a major factor affecting engine performance and service life. Non-detergent or vegetable oils are not recommended.
- Be sure to check the tiller on a level surface with the engine stopped.

Use Honda 4-stroke oil, or an equivalent high detergent, premium quality motor oil certified to meet or exceed U.S. automobile manufacturer's requirements for Service Classification SE or SF. (Motor oils classified SE or SF will show this designation on the container.)

SAE 10W-40 is recommended for general, all-temperature use.

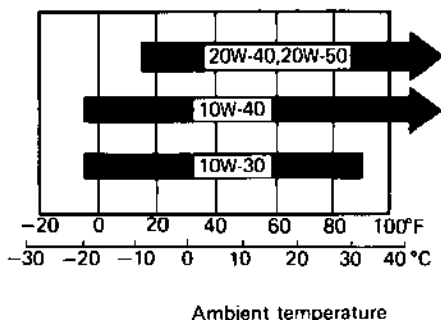

1. Remove the oil filler cap and wipe the dipstick clean.
2. Insert the dipstick into the oil filler neck, but do not screw it in.
3. If the level is low, fill to the top of the oil filler neck with the recommended oil.

CAUTION: Running the engine with insufficient oil can cause serious engine damage.

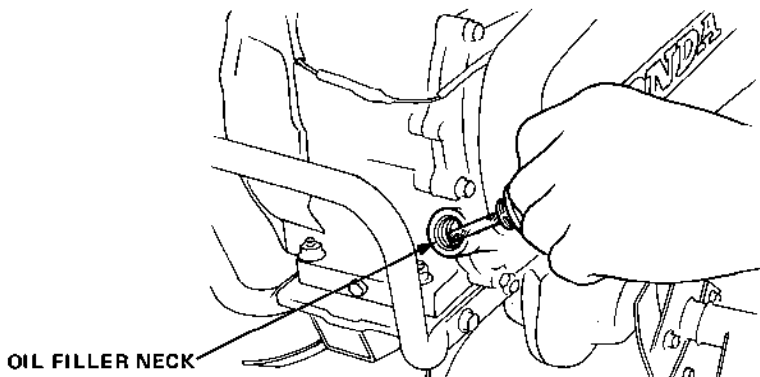

2. Transmission gear oil

Place the tiller on a level surface and remove the oil filler cap. The oil should be level with the lower edge of the oil filler hole. Add high quality engine oil if the level is low.

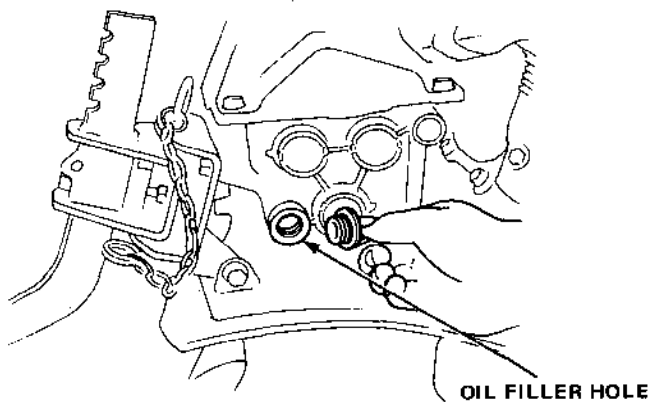

3. Air cleaner

Check cleaner for dirt or obstruction of elements.

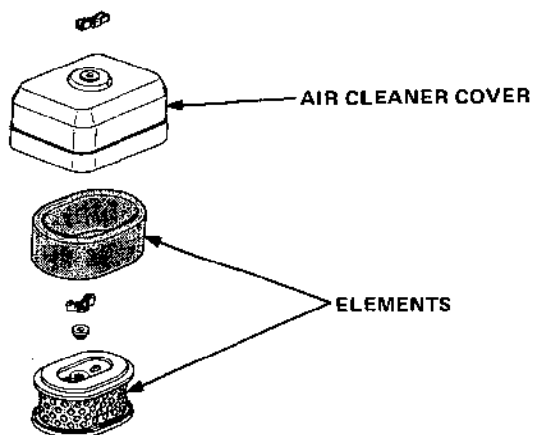

4. Fuel

Your engine is designed to use any gasoline that has a pump octane number $\left(\frac{R+M}{2}\right)$ of 86 or higher, or that has a research octane number of 91 or higher. Gasoline pumps at service station normally display the pump octane number.

We recommend that you use unleaded fuel because it produces fewer engine and spark plug deposits and extends the life of exhaust system components.

Never use stale or contaminated gasoline or an oil/gasoline mixture. Avoid getting dirt, dust or water in the fuel tank. Use of a lower octane gasoline can cause persistent "pinging" or heavy "spark knock" (a metallic rapping noise) which, if severe, can lead to engine damage.

CAUTION: If "spark knock" or "pinging" occurs at a steady engine speed under normal load, change brands of gasoline. If spark knock or pinging persists, consult your authorized Honda dealer. Failure to do so is considered misuse, and damage caused by misuse is not covered by Honda's Limited Warranty.

Occasionally you may experience light spark knock while operating under heavy loads. This is no cause for concern, it simply means your engine is operating efficiently.

CAUTION: Do not fill over the red level line.

Fuel tank capacity: F401.....1.4 l (0.37 US Gal)
F501.....2.6 l (0.69 US Gal)

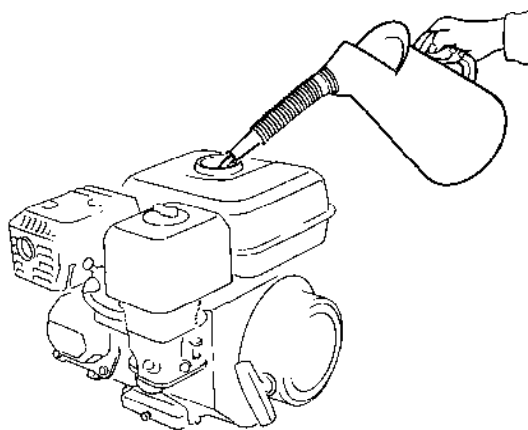

WARNING

- Gasoline is extremely flammable and is explosive under certain conditions.
- Refuel in a well-ventilated area with the engine stopped. Do not smoke or allow flames or sparks in the area where the engine is refueled or where gasoline is stored.
- Do not overfill the fuel tank (there should be no fuel in the filler neck). After refueling, make sure the tank cap is closed properly and securely.
- Be careful not to spill fuel when refueling. Spilled fuel or fuel vapor may ignite. If any fuel is spilled, make sure the area is dry before starting the engine.
- Avoid repeated or prolonged contact with skin or breathing of vapor. **KEEP OUT OF REACH OF CHILDREN.**

GASOLINES CONTAINING ALCOHOL

If you decide to use a gasoline containing alcohol (gasohol), be sure it's octane rating is at least as high as that recommended by Honda. There are two types of "gasohol": one containing ethanol, and the other containing methanol. Do not use gasohol that contains more than 10% ethanol. Do not use gasoline containing methanol (methyl or wood alcohol) that does not also contain cosolvents and corrosion inhibitors for methanol. Never use gasoline containing more than 5% methanol, even if it has cosolvents and corrosion inhibitors.

NOTE:

- Fuel system damage or engine performance problems resulting from the use of fuels that contain alcohol is not covered under the warranty. Honda cannot endorse the use of fuels containing methanol since evidence of their suitability is as yet incomplete.
- Before buying fuel from an unfamiliar station, try to find out if the fuel contains alcohol, if it does, confirm the type and percentage of alcohol used. If you notice any undesirable operating symptoms while using a gasoline that contains alcohol, or one that you think contains alcohol, switch to a gasoline that you know does not contain alcohol.

4. STARTING THE ENGINE

CAUTION: Be sure the clutch is disengaged and the shift lever is in the neutral position to prevent sudden uncontrolled movement when the engine starts. The clutch is engaged by pulling in the clutch lever and disengaged by releasing the lever.

1. Turn the fuel valve ON.

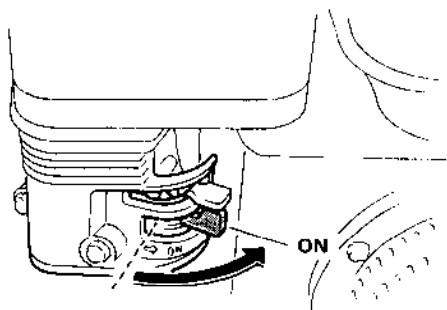

2. Close the choke lever.

NOTE: Do not use the choke if the engine is warm or the air temperature is high.

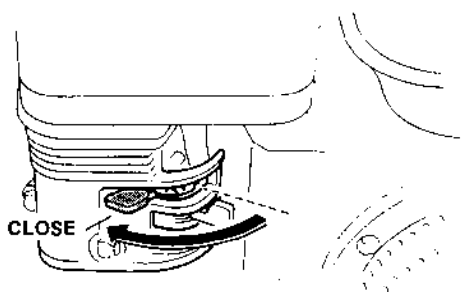

3. Turn the engine switch to the ON position.

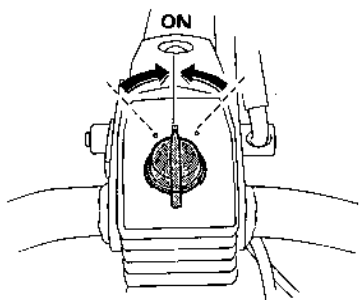

4. Move the throttle lever slightly to the left.

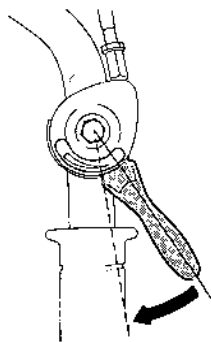

5. Pull the starter grip lightly until resistance is felt, then pull briskly.

CAUTION: Do not allow the starter grip to snap back against the engine. Return it gently to prevent damage to the starter.

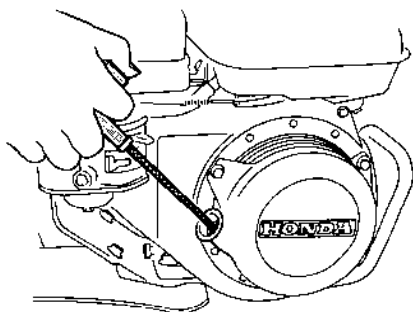

6. As the engine warms up, gradually open the choke.

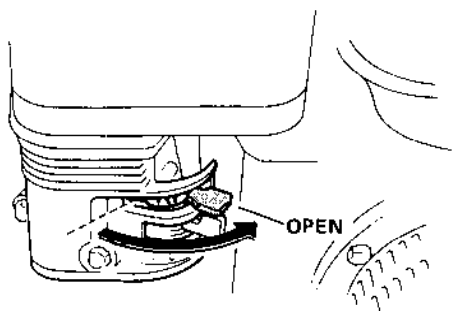

5. TILLER OPERATION

1. Handlebar height adjustment

CAUTION: Before adjusting the handlebar, place the tiller on firm level ground to prevent the handle from collapsing accidentally.

To adjust the handlebar height, loosen the adjuster, select the appropriate holes and tighten the adjuster.

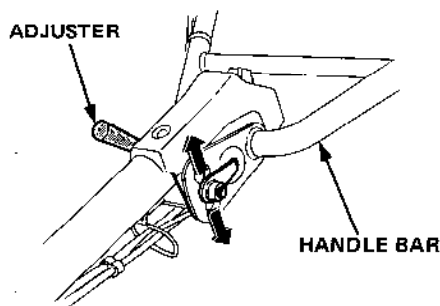

2. Tilling depth adjustment

Tilling depth can be adjusted by removing the retainer and sliding the drag bar up or down as necessary.

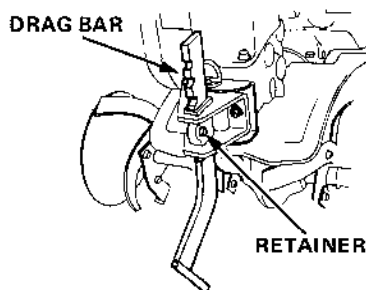

3. Clutch

The clutch engages and disengages the power from the engine to the transmission.

When the clutch lever is squeezed, the clutch is engaged and power is transmitted.

When the lever is released, the clutch is disengaged and power is not transmitted.

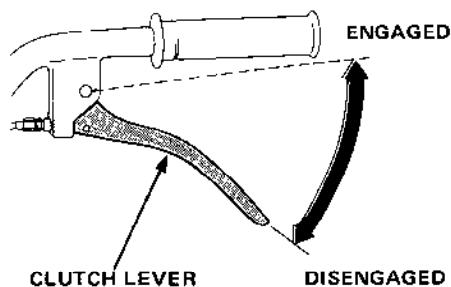

4. Gear selection (A2 type only)

The transmission on the A2 type tiller offers a choice of two forward speeds and one reverse. Shift lever positions are indicated on the Gear Shifting Plate.

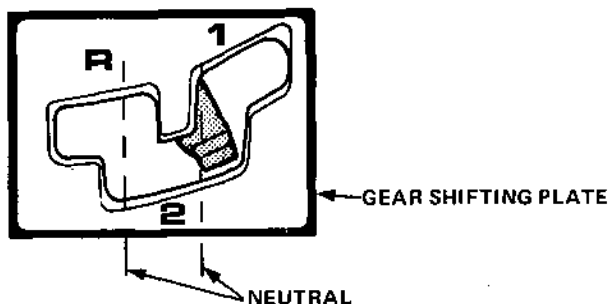

Shift Lever Operation:

1. Return the throttle lever to the extreme right.
2. Release the clutch lever to disengage the clutch.
3. Move the shift lever to the desired gear position.

NOTE: If the shift lever will not engage the desired gear, squeeze the clutch lever and move the tiller slightly to reposition the gears.

5. Hitch box

Use a hitch pin as shown below to attach the drag bar or any other attachments to the hitch box.

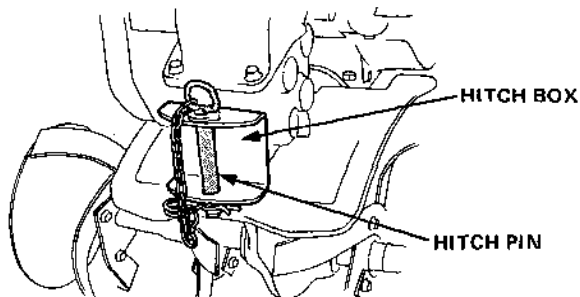

6. Front wheel

Use a front wheel to move the tiller on road. Lift the handlebars up and ground the front wheel.

When the tiller is used in the field, move the wheel up by replacing the lock pin.

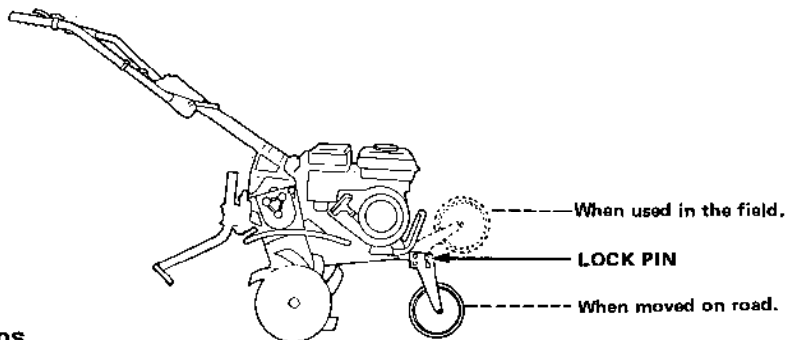

7. Handling tips

Adjust the handlebar height to a comfortable position (waist height for normal tilling).

Should the machine jerk forward while tilling, press down on the handlebars.

If the machine will not move forward, move the handlebars from side to side.

Turn: The proper method of negotiating a turn during a tilling operation is to lower the handlebars to bring the weight toward the rear and then make the turn.

This will permit a turn to be made with relative ease.

• High altitude operation

At high altitude, the standard carburetor air-fuel mixture will be excessively rich. Performance will decrease, and fuel consumption will increase.

High altitude performance can be improved by installing a smaller diameter main fuel jet in the carburetor and readjusting the pilot screw. If you always operate the riding mower at altitudes higher than 6,000 feet above sea level, have your authorized Honda Rotary Mower dealer perform these carburetor modifications.

Even with suitable carburetor jetting, engine horsepower will decrease approximately 3.5% for each 1,000 foot increase in altitude. The affect of altitude on horsepower will be greater than this if no carburetor modification is made.

CAUTION: Operation of the mower at an altitude lower than the carburetor is jetted for may result in reduced performance, overheating, and serious engine damage caused by an excessively lean air/fuel mixture.

6. STOPPING THE ENGINE

1. Move the throttle lever fully to the right.

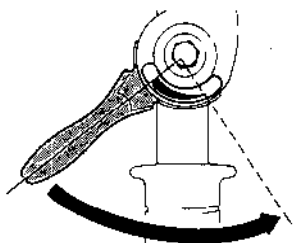

2. Turn the engine switch to the OFF position.

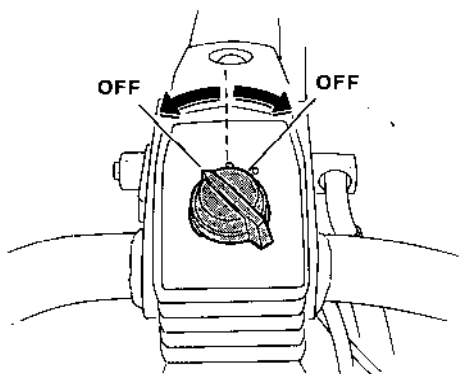

3. Turn the fuel valve OFF.

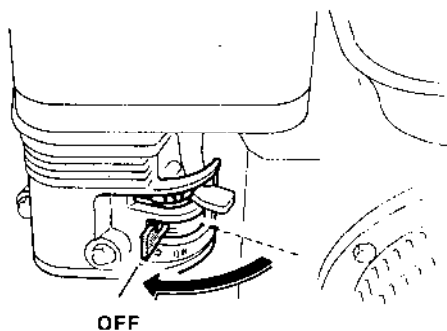

7. MAINTENANCE

The purpose of the maintenance schedule is to keep the tiller in the best operating condition. Inspect or service as scheduled in the table below.

WARNING Shut off the engine before performing any maintenance. If the engine must be run, make sure the area is well ventilated. The exhaust contains poisonous carbon monoxide gas.

CAUTION: Use only genuine HONDA parts or their equivalent for maintenance or repair. Replacement parts which are not of equivalent quality may damage the tiller.

Maintenance Schedule

| REGULAR SERVICE PERIOD Perform at every indicated month or operating hour interval, whichever occurs first. | | Daily | First month or 20 Hrs. | Every 3 months or 50 Hrs. | Every 6 months or 100 Hrs. | Every year or 300 Hrs. |
|---|------------|------------------------|---------------------------------|------------------------------------|-------------------------------------|---------------------------------|
| ITEM | | | | | | |
| Engine oil | Inspection | ○ | | | | |
| | Change | | ○ | | ○ | |
| Air cleaner element | Inspection | ○ | | | | |
| | Cleaning | | | ○ (1) | | |
| Sediment cup cleaning | | | | | ○ | |
| Spark plug maintenance | | | | | ○ | |
| Transmission gear oil inspection | | ○ | | | | |
| Tappet clearance adjustment | | | | | | ○ (2) |
| Combustion chamber cleaning | | | | | | ○ (2) |
| Fuel tank cleaning | | | | | | ○ (2) |
| Clutch cable adjustment | | | ○ | | ○ | |
| Throttle cable adjustment | | | | | | ○ |
| V-belt tension adjustment | | | ○ | | ○ | |
| Fuel line | | Replace every 3 years. | | | | |

NOTE (1): Service more frequently when used in dusty areas.

(2): These items should be serviced by an authorized Honda dealer, unless the owner has the proper tools and is mechanically proficient. See the Honda Shop Manual.

1. Changing oil

Drain the oil while the engine is still warm to assure rapid and complete draining.

1. Remove the oil filler cap and the drain plug.
2. Tilt the tiller back to drain the crankcase completely.
3. Replace the drain plug, refill with the recommended oil (p. 5), and replace the oil filler cap.

OIL CAPACITY: 0.6ℓ (0.63 US qt)

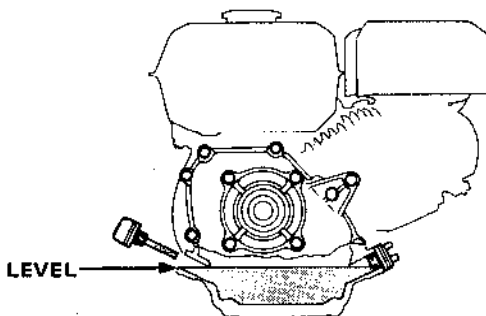
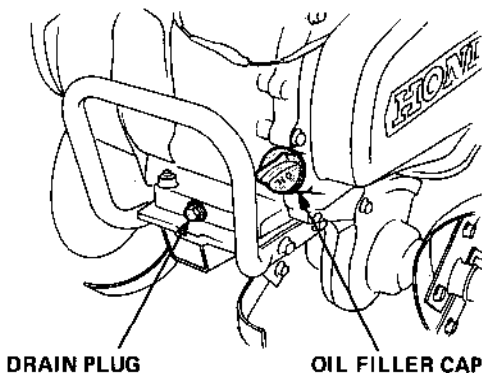

CAUTION: Used motor oil may cause skin cancer if repeatedly left in contact with the skin for prolonged periods. Although this is unlikely unless you handle used oil on a daily basis, it is still advisable to thoroughly wash your hands with soap and water as soon as possible after handling used oil.

NOTE: Please dispose of used motor oil in a manner that is compatible with the environment. We suggest you take it in a sealed container to your local service station for reclamation. Do not throw it in the trash or pour it on the ground.

2. Air cleaner service

A dirty air cleaner will restrict air flow to the carburetor. To prevent carburetor malfunction, service the air cleaner regularly. Service more frequently when operating the engine in extremely dusty areas.

WARNING Never use gasoline or low flash point solvents for cleaning the air cleaner element. A fire or explosion could result.

CAUTION: Never run the engine without the air cleaner. Rapid engine wear will result.

1. Remove the wing nut and the air cleaner cover. Remove the elements and separate them. Carefully check both elements for holes or tears and replace if damaged.
2. Foam element: Clean in warm soapy water, rinse and allow to dry thoroughly. Or clean in high flash-point solvent and allow to dry. Dip the element in clean engine oil and squeeze out all the excess. The engine will smoke during initial start-up if too much oil is left in the foam.
3. Paper element: Tap the element lightly several times on a hard surface to remove excess dirt, or blow compressed air through the filter from the inside out. Never try to brush the dirt off; brushing will force dirt into the fibers.

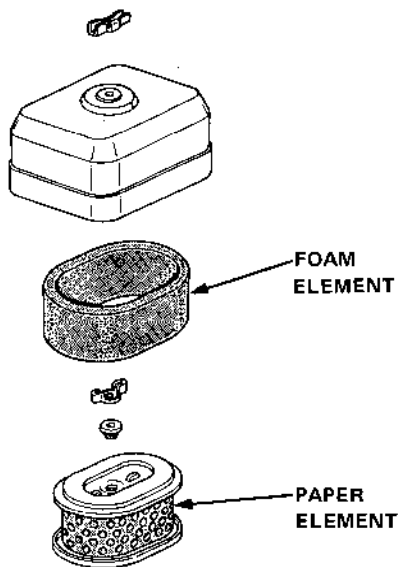

3. Clean sediment cup

Turn the fuel valve to the off position and remove the sediment cup and O-ring.

Wash removed parts in solvent, dry them thoroughly and reinstall them securely. Turn the fuel valve ON and check for leaks.

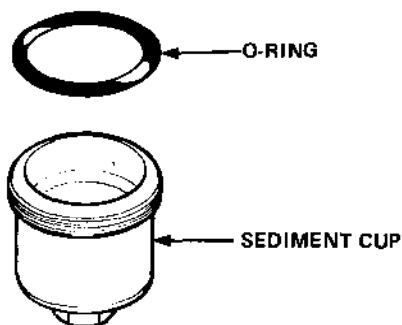

4. Spark plug service

Recommended spark plug: BPR5ES (NGK)
W16EPR-U (ND)

To ensure proper engine operation, the spark plug must be properly gapped and free of deposits.

1. Remove the spark plug cap.

WARNING If the engine has been running, the muffler will be very hot. Be careful not to touch the muffler.

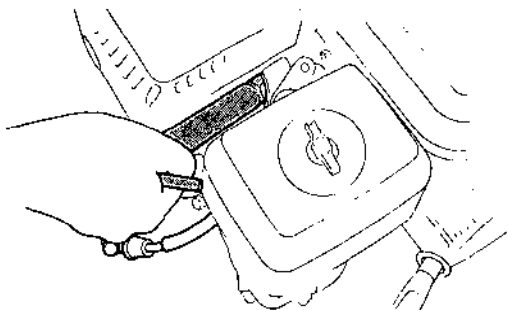

2. Visually inspect the spark plug. Discard it if the insulator is cracked or chipped. Clean the spark plug with a wire brush if it is to be reused.
3. Measure the plug gap with a feeler gauge. The gap should be 0.7–0.8 mm (0.028–0.031 in). Correct as necessary by bending the side electrode.

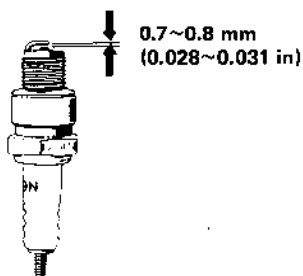

4. Attach the plug washer. Thread the plug in by hand to prevent cross-threading.

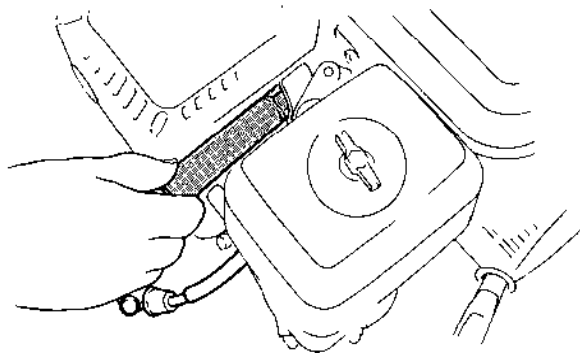

5. Tighten a new spark plug 1/2 turn with the wrench to compress the washer. If you are reusing a plug, it should only take 1/8–1/4 turn after the plug seats.

CAUTION: The spark plug must be securely tightened. An improperly tightened plug can become very hot and possibly damage the engine. Never use a spark plug with an improper heat range.

5. Clutch cable adjustment

There should be no free play at the lever end.

If lever adjustment is incorrect, loosen the lock nut and turn the adjusting bolt in or out just enough to eliminate free play. Do not overtighten.

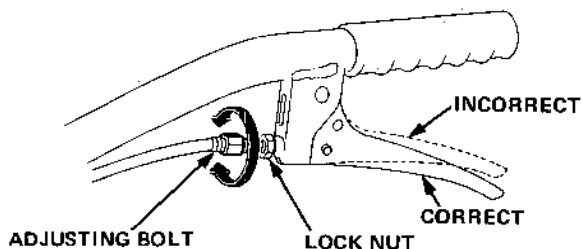

After adjustment, tighten the lock nut securely. Then start the engine and check for proper clutch operation.

6. Throttle cable adjustment

Measure the free play at the lever tip.

Free play: 5–10 mm (0.2–0.4 in)

If the free play is incorrect, loosen the lock nut and turn the adjusting nut in or out as required.

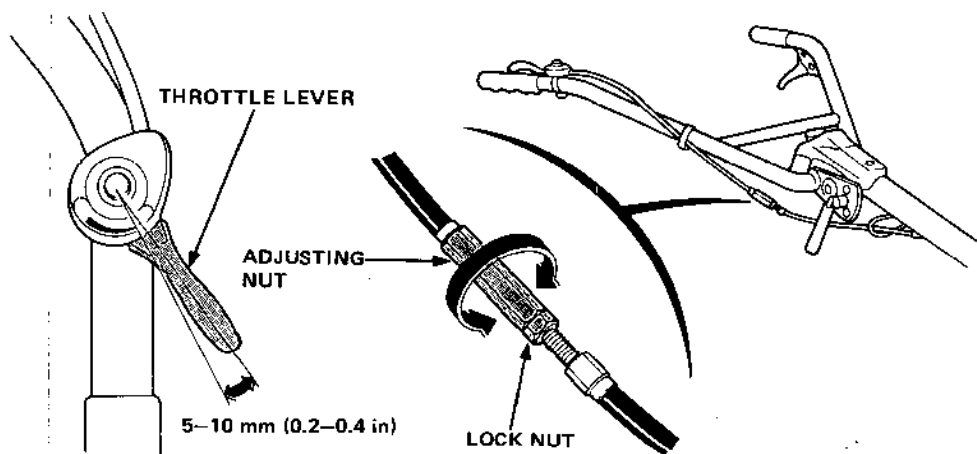

7. Belt tension adjustment

1. Adjust the clutch lever free play (Page 20). Belt tension is correct when the distance from the top of the belt to the top of the tension roller is 60–65 mm (2.4–2.5 in) when the clutch is engaged.

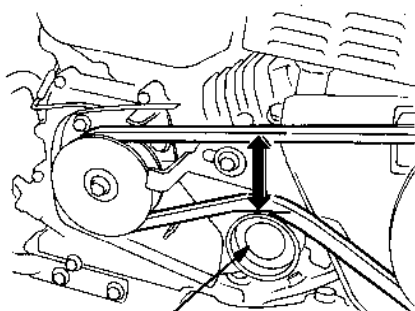

TENSION ROLLER

2. To adjust, loosen the four engine mounting bolts and the engine stay tightening bolt and move the engine forward or backward to get proper tension on the belt.

NOTE: After adjusting the tension, use a straight edge to make sure that the outside face of the drive pulley is flush with the outside face of the driven pulley.

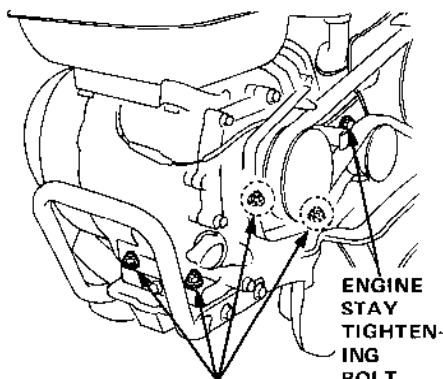

MOUNTING BOLTS

ENGINE STAY TIGHTENING BOLT

3. Loosen the belt stopper attaching bolts. Adjust the clearance between the belt stopper and the belt as illustrated with the clutch lever squeezed.

STANDARD CLEARANCE:
3 mm (0.12 in)

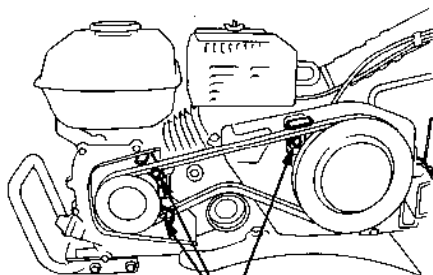

BELT STOPPER

8. TRANSPORTING/STORAGE

WARNING When transporting the tiller, turn the fuel valve OFF and keep the tiller level to prevent fuel spillage. Fuel vapor or spilled fuel may ignite.

Before storing the unit for an extended period;

1. Be sure the storage area is free of excessive humidity and dust.
2. Drain the fuel ...
 - a. With the fuel valve turned OFF, remove and empty the sediment cup.
 - b. Turn the fuel valve ON and drain the gasoline in the fuel tank into the suitable container.
 - c. Replace the sediment cup and tighten securely.
 - d. Drain the carburetor by removing the drain screw.
Drain the gasoline into a suitable container. Replace the drain screw.

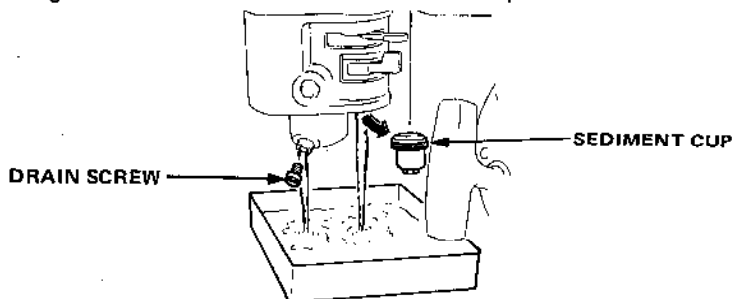

3. Pull the starter cord until resistance is felt. Continue pulling until the notch on the starter pulley aligns with the hole on the recoil starter (see illustration below). At this point, the intake and exhaust valves are closed, and this will help to protect the engine from internal corrosion.

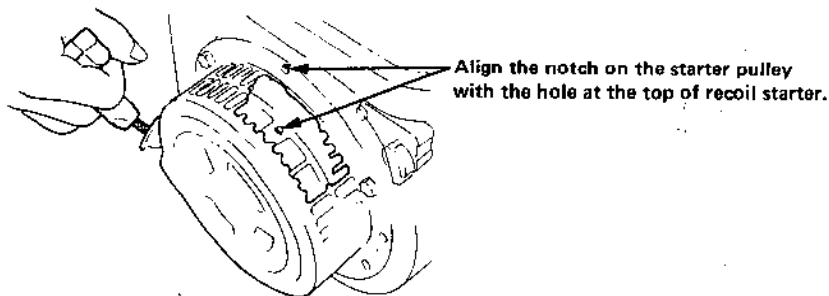

4. Change engine oil. (If anticipated storage will exceed 1 year.)
5. Cover tiller with plastic sheet.

9. TROUBLESHOOTING

When the engine will not start;

1. Is there enough fuel?
2. Is the fuel valve on?
3. Is the engine switch ON?
4. Is gasoline reaching the carburetor?

To check, loosen the drain screw with the fuel valve on. Fuel should flow out freely. Retighten drain screw.

WARNING If any fuel is spilled, make sure the area is dry before testing the spark plug or starting the engine. Fuel vapor or spilled fuel may ignite.

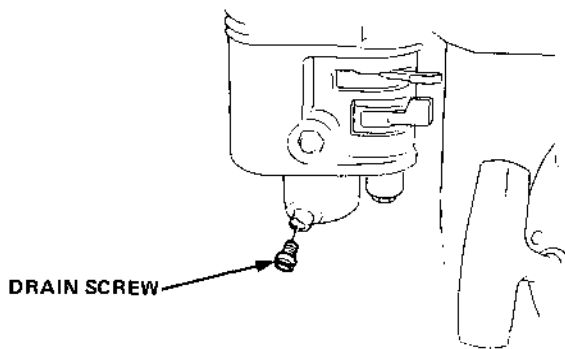

5. Is there a spark at the spark plug?

- a. Remove the spark plug cap. Clean any dirt from around the spark plug base, then remove the spark plug.
 - b. Install the spark plug in the plug cap.
 - c. Turn the engine switch on.
 - d. Grounding the side electrode to any engine ground, pull the recoil starter to see if sparks jump across the gap.
 - e. If there is no spark, replace the plug.
- If OK, try to start the engine according to the instructions.

6. If the engine still does not start, take the tiller to an authorized Honda dealer.

10. SPECIFICATIONS

| Model | F401-AD | F401-A2 | F501-A1 | F501-A2 |
|---------------------------|--|------------------|---------------------------------|------------------|
| Dimensions and weight | | | | |
| Dry Weight | 34 kg (75.0 lb) | | 36 kg (79.4 lb) | |
| Length | 1,320 mm (52.0 in) | | | |
| Width | 655 mm (25.8 in) | 670 mm (26.3 in) | | 955 mm (37.6 in) |
| Height | 970 mm (38.2 in) | 995 mm (39.2 in) | | |
| Engine Model | GX 110 | | GX 140 | |
| Type | 4-Stroke, 1-Cylinder, OHV, Forced Air Cooled | | | |
| Displacement | 107 cm ³ (6.5 cu in) | | 144 cm ³ (8.8 cu in) | |
| Bore x Stroke | 57 x 42 mm (2.2 x 1.7 in) | | 64 x 45 mm (2.5 x 1.8 in) | |
| Ignition System | Transistor Magneto | | | |
| Spark Plug | BPR5ES (NGK), W16EPR-U (ND) | | | |
| Oil Capacity | 0.6 ℓ (0.63 US qt) | | | |
| Fuel Tank Capacity | 1.4 ℓ (0.37 US gal) | | 2.6 ℓ (0.69 US gal) | |
| Clutch | Belt Tension | | | |
| Transmission oil capacity | 0.95 ℓ (1.0 US qt) | | | |

11. WARRANTY SERVICE

Owner Satisfaction

Your satisfaction and goodwill are important to your dealer and to us. All Honda warranty details are explained in the Distributor's Limited Warranty. Normally, any problems concerning the product will be handled by your dealer's service department. If you have a warranty problem that has not been handled to your satisfaction, we suggest you take the following action:

- Discuss your problem with a member of dealership management. Often complaints can be quickly resolved at that level. If the problem has already been reviewed with the Service Manager, contact the owner of the dealership or the General Manager.
- If your problem still has not been resolved to your satisfaction, contact the Power Equipment Customer Relations Department of American Honda Motor Co., Inc.

American Honda Motor Co., Inc.
Power Equipment Customer Relations Department
P.O. Box 50
Gardena, California 90247-0805
Telephone: (213) 604-2400

We will need the following information in order to assist you:

- Your name, address, and telephone number
- Product model and serial number
- Date of purchase
- Dealer name and address
- Nature of the problem

After reviewing all the facts involved, you will be advised of what action can be taken. Please bear in mind that your problem will likely be resolved at the dealership, using the dealer's facilities, equipment, and personnel, so it is very important that your initial contact be with the dealer.

Your purchase of a Honda product is greatly appreciated by both your dealer and American Honda Motor Co., Inc. We want to assist you in every way possible to assure your complete satisfaction with your purchase.

Current customer service contact information:

United States, Puerto Rico, and U.S. Virgin Islands:

Honda Power Equipment dealership personnel are trained professionals. They should be able to answer any question you may have. If you encounter a problem that your dealer does not solve to your satisfaction, please discuss it with the dealership's management. The Service Manager or General Manager can help. Almost all problems are solved in this way.

If you are dissatisfied with the decision made by the dealership's management, contact the Honda Power Equipment Customer Relations Office. You can write:

American Honda Motor Co., Inc.
Power Equipment Division
Customer Relations Office
4900 Marconi Drive
Alpharetta, GA 30005-8847

Or telephone: (770) 497-6400 M-F, 8:30 am - 7:00 pm EST

When you write or call, please provide the following information:

- Model and serial numbers
- Name of the dealer who sold the Honda power equipment to you
- Name and address of the dealer who services your equipment
- Date of purchase
- Your name, address, and telephone number
- A detailed description of the problem



HONDA
HONDA MOTOR CO., LTD. TOKYO, JAPAN

31733030
00X31-733-0300

AF 英 Y 4008911
PRINTED IN JAPAN