

HONDA

Power

Equipment

Owner's Manual

GENERATOR

EP2500CX

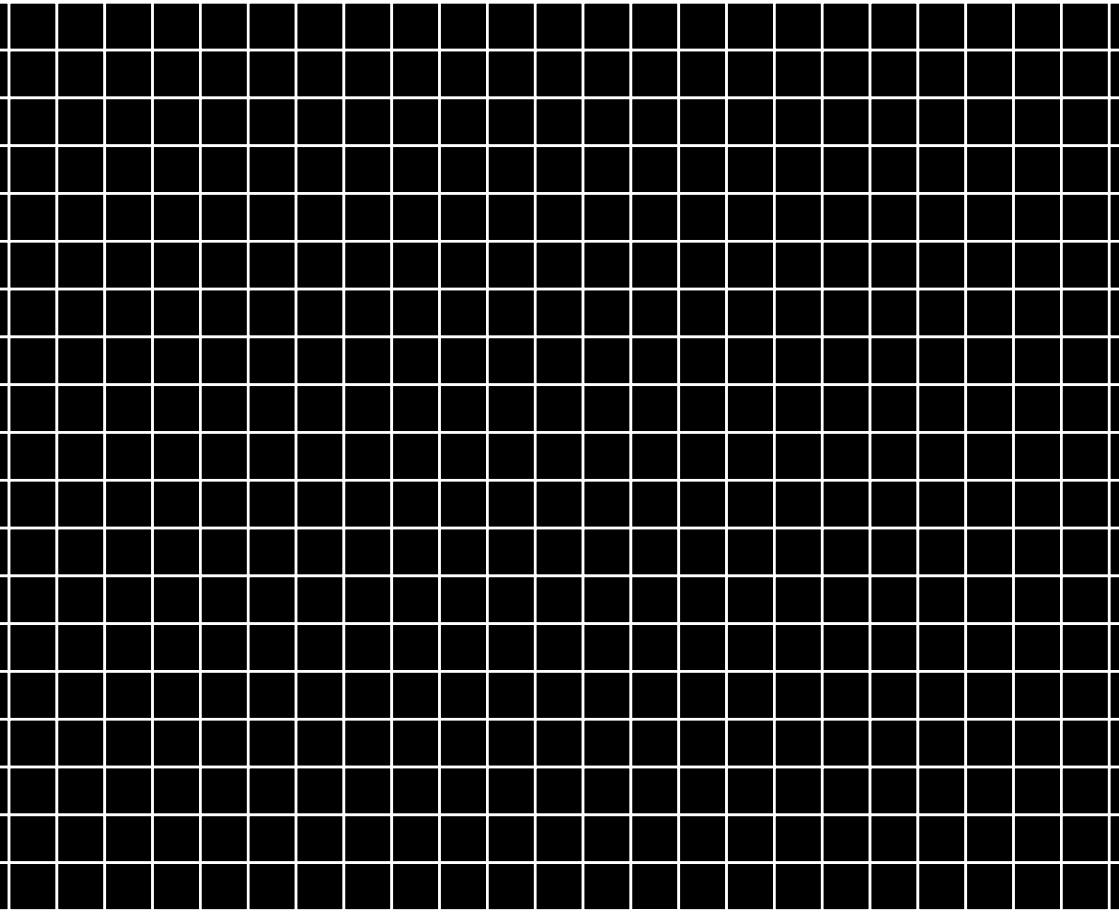



WARNING:



The engine exhaust from this product contains chemicals known to the State of California to cause cancer, birth defects or other reproductive harm.

⚠ WARNING

Exhaust contains poisonous carbon monoxide gas that can build up to dangerous levels in closed areas. Breathing carbon monoxide can cause unconsciousness or death.

Never run the generator in a closed, or even partly closed area where people may be present.

Keep this owner's manual handy so that you can refer to it at any time. This owner's manual is considered a permanent part of the generator and should remain with the generator if resold.

The information and specifications included in this publication were in effect at the time of approval for printing. Honda Motor Co., Ltd. reserves the right, however, to discontinue or change specifications or design at any time without notice and without incurring any obligation whatever.

INTRODUCTION

Congratulations on your selection of a Honda generator. We are certain you will be pleased with your purchase of one of the finest generators on the market.

We want to help you get the best results from your new generator and to operate it safely. This manual contains all the information on how to do that; please read it carefully.

As you read this manual, you will find information preceded by a **NOTICE** symbol. That information is intended to help you avoid damage to your generator, other property, or the environment.

We suggest you read the *Distributor's Limited Warranty* to fully understand its coverage and your responsibilities of ownership. The *Distributor's Limited Warranty* is a separate document that should have been given to you by your dealer.

When your generator needs scheduled maintenance, keep in mind that your Honda servicing dealer is specially trained in servicing Honda generators and is supported by the parts and service divisions of American Honda. Your Honda servicing dealer is dedicated to your satisfaction and will be pleased to answer your questions and concerns.

Best Wishes,
Honda Motor Co., Ltd.

A FEW WORDS ABOUT SAFETY

Your safety and the safety of others are very important. And using this generator safely is an important responsibility.

To help you make informed decisions about safety, we have provided operating procedures and other information on labels and in this manual. This information alerts you to potential hazards that could hurt you or others.

Of course, it is not practical or possible to warn you about all the hazards associated with operating or maintaining a generator. You must use your own good judgement.

You will find important safety information in a variety of forms, including:

- **Safety Labels** — on the generator.
- **Safety Messages** — preceded by a safety alert symbol  and one of three signal words, DANGER, WARNING, or CAUTION.

These signal words mean:

 **DANGER**

You **WILL** be **KILLED** or **SERIOUSLY HURT** if you don't follow instructions.

 **WARNING**

You **CAN** be **KILLED** or **SERIOUSLY HURT** if you don't follow instructions.

 **CAUTION**

You **CAN** be **HURT** if you don't follow instructions.

- **Safety Headings** — such as *IMPORTANT SAFETY INFORMATION*.
- **Safety Section** — such as *GENERATOR SAFETY*.
- **Instructions** — how to use this generator correctly and safely.

This entire book is filled with important safety information — please read it carefully.

CONTENTS

GENERATOR SAFETY	6
IMPORTANT SAFETY INFORMATION	6
Operator Responsibility.....	6
Carbon Monoxide Hazards.....	6
Electric Shock Hazards	7
Fire and Burn Hazards	7
Refuel With Care	8
SAFETY LABEL LOCATIONS	9
CONTROLS & FEATURES	10
COMPONENT & CONTROL LOCATIONS	10
CONTROLS	12
Fuel Valve Lever	12
Choke Lever	12
Engine Switch.....	13
Starter Grip	13
AC Circuit Breaker	13
FEATURES	14
Oil Alert® System	14
Ground Terminal.....	14
Fuel Gauge.....	15
BEFORE OPERATION	16
ARE YOU READY TO GET STARTED?	16
Knowledge.....	16
IS YOUR GENERATOR READY TO GO?	16
Check the Engine.....	17

CONTENTS

OPERATION	18
SAFE OPERATING PRECAUTIONS	18
STARTING THE ENGINE	20
STOPPING THE ENGINE	22
AC OPERATION.....	23
AC Applications.....	24
STANDBY POWER.....	25
Connections to a Building’s Electrical System	25
System Ground	25
Special Requirements.....	26
SERVICING YOUR GENERATOR	27
THE IMPORTANCE OF MAINTENANCE	27
MAINTENANCE SAFETY.....	28
Safety Precautions	28
MAINTENANCE SCHEDULE	29
REFUELING	30
FUEL RECOMMENDATIONS	31
ENGINE OIL LEVEL CHECK	32
ENGINE OIL CHANGE.....	33
ENGINE OIL RECOMMENDATIONS.....	34
AIR CLEANER SERVICE	35
FORM AIR FILTER CLEANING	37
SEDIMENT CUP CLEANING.....	38
SPARK PLUG SERVICE.....	39
SPARK ARRESTER SERVICE.....	41
STORAGE	43
STORAGE PREPARATION.....	43
Cleaning	43
Fuel.....	43
Engine Oil	46
STORAGE PRECAUTIONS	47
REMOVAL FROM STORAGE.....	47
TRANSPORTING	48

CONTENTS

TAKING CARE OF UNEXPECTED PROBLEMS	49
ENGINE WILL NOT START.....	49
ENGINE LACKS POWER.....	50
NO POWER AT THE RECEPTACLES.....	51
TECHNICAL & CONSUMER INFORMATION	52
TECHNICAL INFORMATION	52
Serial Number Location	52
Carburetor Modification for High Altitude Operation.....	53
Emission Control System Information.....	54
Air Index.....	56
Specifications	57
Wiring Diagram	58
CONSUMER INFORMATION	59
Dealer Locator Information	59
Honda Publications	59
Customer Service Information.....	60
INITIAL USE INSTRUCTIONS	61
ENGINE OIL	61
FUEL.....	61
BEFORE OPERATION	62
INDEX	63
QUICK REFERENCE INFORMATION	Inside back cover

GENERATOR SAFETY

IMPORTANT SAFETY INFORMATION

Honda generators are designed for use with electrical equipment that has suitable power requirements. Other uses can result in injury to the operator or damage to the generator and other property.

Most accidents can be prevented if you follow all instructions in this manual and on the generator. The most common hazards are discussed below, along with the best way to protect yourself and others.

Operator Responsibility

- Know how to stop the generator quickly in case of emergency.
- Understand the use of all generator controls, output receptacles, and connections.
- Be sure that anyone who operates the generator receives proper instruction. Do not let children operate the generator without parental supervision.

Carbon Monoxide Hazards

- Exhaust contains poisonous carbon monoxide, a colorless, odorless gas. Breathing carbon monoxide can cause loss of consciousness and may lead to death.
- If you run the generator in an area that is confined, or even partly enclosed area, the air you breathe could contain dangerous amount of exhaust gas.
- Never run your generator inside a garage, house, or near open windows or doors.

Electric Shock Hazards

- The generator produces enough electric power to cause a serious shock or electrocution if misused.
- Using a generator or electrical appliance in wet conditions, such as rain or snow, or near a pool or sprinkler system, or when your hands are wet, could result in electrocution. Keep the generator dry.
- If the generator is stored outdoors, unprotected from the weather, check all of the electrical components on the control panel before each use. Moisture or ice can cause a malfunction or short circuit in electrical components that could result in electrocution.
- Do not connect to a building's electrical system unless an isolation switch has been installed by a qualified electrician.

Fire and Burn Hazards

- The exhaust system gets hot enough to ignite some materials.
 - Keep the generator at least 3 feet (1 meter) away from buildings and other equipment during operation.
 - Do not enclose the generator in any structure.
 - Keep flammable materials away from the generator.
- The muffler becomes very hot during operation and remains hot for a while after stopping the engine. Be careful not to touch the muffler while it is hot. Let the engine cool before storing the generator indoors.

GENERATOR SAFETY















Refuel With Care

Gasoline is extremely flammable, and gasoline vapor can explode. Allow the engine to cool if the generator has been in operation. Refuel only outdoors in a well-ventilated area with the engine OFF. Do not overfill the fuel tank. Never smoke near gasoline, and keep other flames and sparks away. Always store gasoline in an approved container. Make sure that any spilled fuel has been wiped up before starting the engine.



GENERATOR SAFETY

SAFETY LABEL LOCATIONS

These labels warn you of potential hazards that can cause serious injury. Read them carefully. If a label comes off or becomes hard to read, contact your Honda servicing dealer for a replacement.



<p>⚠ DANGER</p> <p>Using a generator indoors CAN KILL YOU IN MINUTES. Generator exhaust contains carbon monoxide. This is a poison you cannot see or smell.</p> <p> NEVER use inside a home or garage. EVEN IF doors and windows are open.</p> <p> Only use OUTSIDE and far away from windows, doors, and vents.</p>	<p> Gasoline is highly flammable and explosive. You could be burned or seriously injured if the gasoline is ignited.</p> <p> Before refueling, stop the engine and keep heat, sparks, and flame away.</p> <p> Handle fuel only outdoors. Do not fill the fuel tank above the upper limit line.</p> <p> Wipe up spills immediately.</p> <p> Exhaust contains poisonous carbon monoxide gas that can build up to dangerous levels in closed areas. Breathing carbon monoxide can cause unconsciousness or death.</p> <p> Never run the generator in a closed, or even partly closed area where people may be present.</p>	<p> Improper connections to a building can allow electrical current to backfeed into utility lines, creating an electrocution hazard.</p> <p> Connections to a building must isolate generator power from utility power and comply with all applicable laws and electrical codes.</p> <p> The generator is a potential source of electrical shock if not kept dry.</p> <p> Do not expose the generator to moisture, rain or snow.</p> <p> Do not operate the generator with wet hands.</p> <p> Read owner's manual carefully before operation.</p>
--	--	--

Non-California type

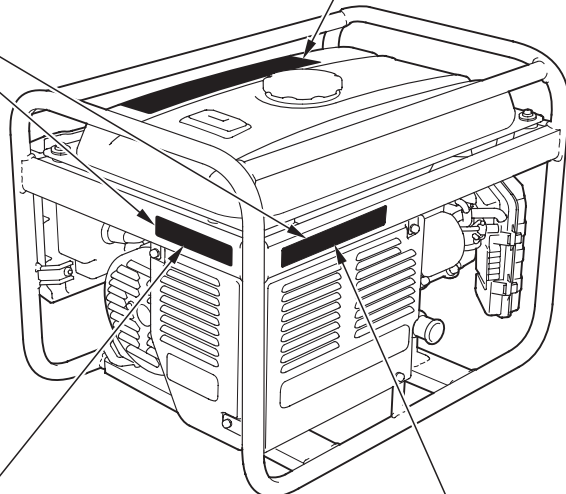

<p></p>	<p>⚠ CAUTION</p> <p> A hot exhaust system can cause serious burns.</p> <p> Avoid contact if the engine has been running.</p>
---	---



California type

<p></p>	<p>⚠ CAUTION</p> <p> A hot exhaust system can cause serious burns.</p> <p> Avoid contact if the engine has been running.</p>
---	---

California type

<p>⚠ WARNING</p> <p>Operation of This Equipment May Create Sparks That Can Start Fires Around Dry Vegetation. A Spark Arrestor May be Required. The Operator Should Contact Local Fire Agencies For Laws or Regulations Relating to Fire Prevention Requirements.</p> <p>Per California Public Resources Code 4442.6</p>	<p></p> <p>⚠ CAUTION</p> <p> A hot exhaust system can cause serious burns.</p> <p> Avoid contact if the engine has been running.</p>
---	--

CONTROLS & FEATURES

COMPONENT & CONTROL LOCATIONS

Use the two illustrations on these pages to locate and identify the most frequently used controls.

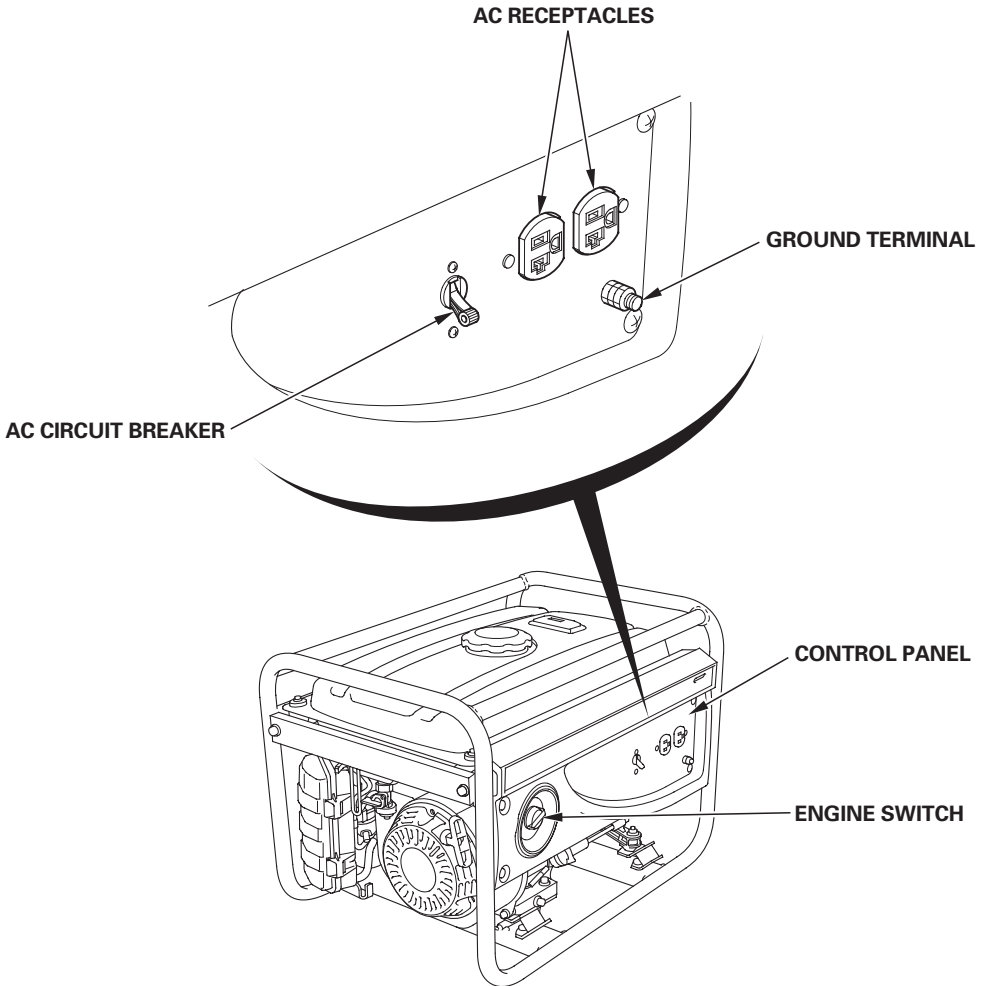

CONTROL & FEATURES

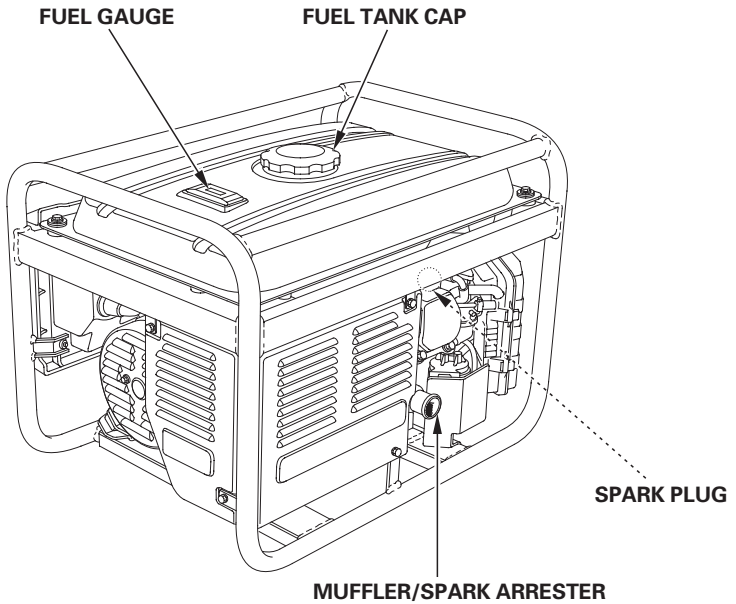
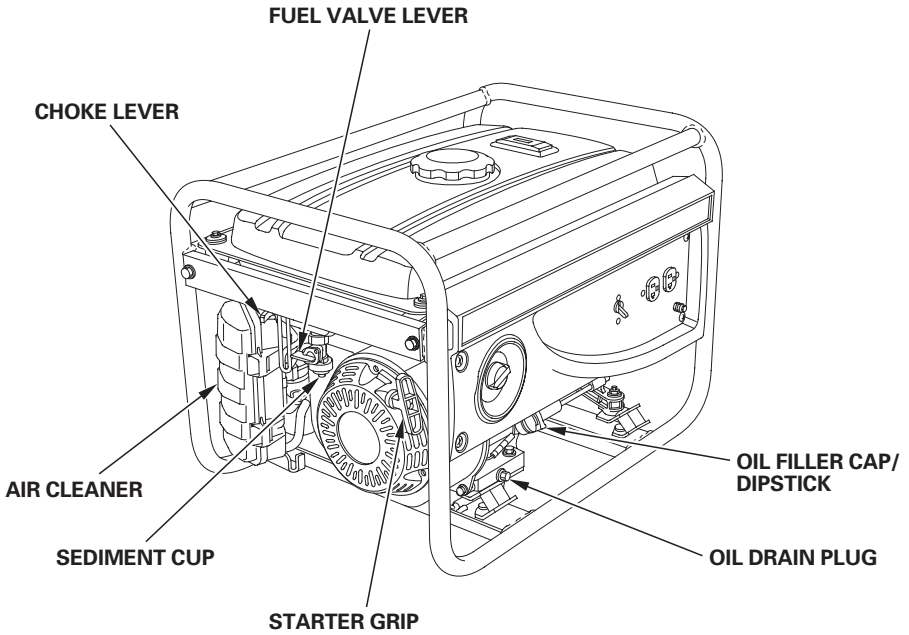

CONTROL & FEATURES

CONTROLS

Fuel Valve Lever

The fuel valve lever is located between the fuel tank and carburetor.

The fuel valve lever must be in the ON position for the engine to run.

After stopping the engine, turn the fuel valve lever to the OFF position.

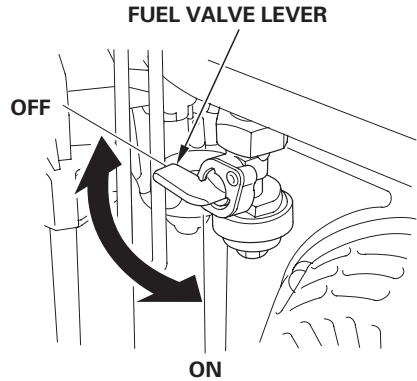

Choke Lever

The choke lever opens and closes the choke valve in the carburetor.

The CLOSED position enriches the fuel mixture for starting a cold engine.

The OPEN position provides the correct fuel mixture for operation after starting, and for restarting a warm engine.

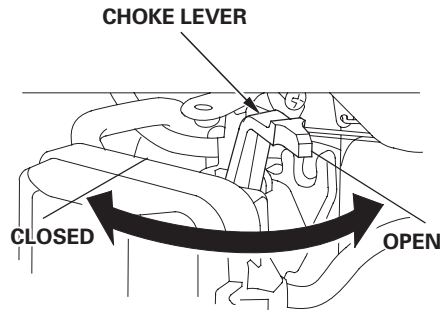

Engine Switch

The engine switch controls the ignition system.

OFF — Stops the engine.

ON — Running position, and for starting.

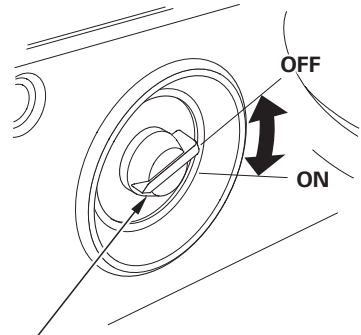

ENGINE SWITCH

Starter Grip

Pulling the starter grip operates the recoil starter to crank the engine for starting.

NOTICE

- *Do not allow the starter grip to snap back against the engine. Return it gently to prevent damage to the starter.*
- *Do not let the starter rope rub against the generator body, or the rope will wear out prematurely.*

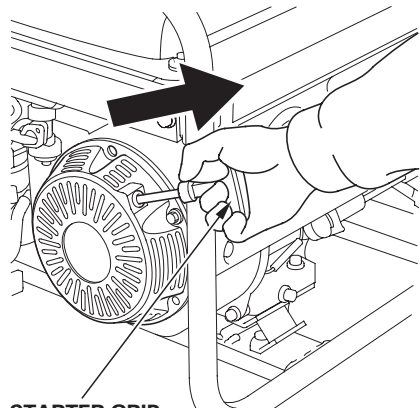

STARTER GRIP

AC Circuit Breaker

The circuit breaker will automatically switch OFF, if there is a short circuit or a significant overload at the receptacles.

The circuit breaker may be used to switch the generator power ON or OFF.

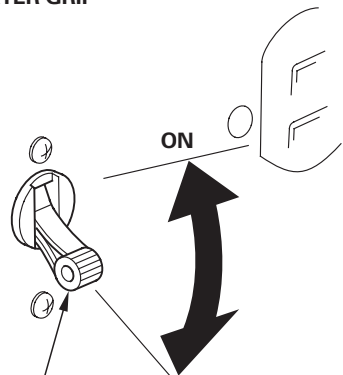

AC CIRCUIT BREAKER

OFF

CONTROL & FEATURES

FEATURES

Oil Alert® System

The Oil Alert system is designed to prevent engine damage caused by an insufficient amount of oil in the crankcase. Before the oil level in the crankcase can fall below a safe limit, the Oil Alert system will automatically stop the engine (the engine switch will remain in the ON position).

If the engine stops and will not restart, check the engine oil level (see page 32) before troubleshooting in other areas.

Ground Terminal

The ground terminal is connected to the frame of the generator, the metal non-current-carrying parts of the generator, and the ground terminals of each receptacle.

Before using the ground terminal, consult a qualified electrician, electrical inspector, or local agency having jurisdiction for local codes or ordinances that apply to the intended use of the generator.

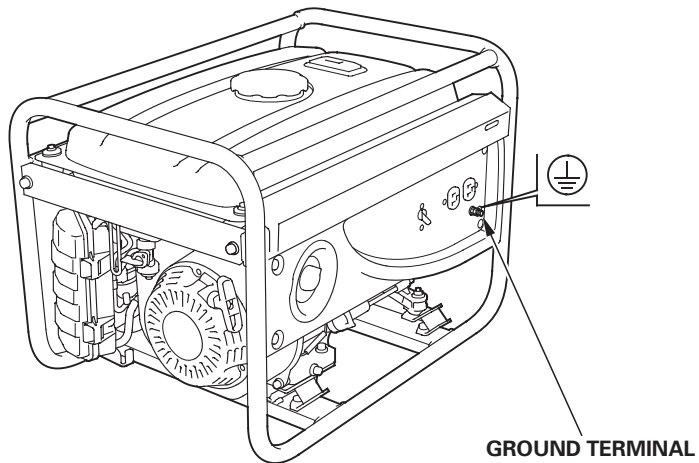

Fuel Gauge

The fuel gauge is a mechanical device that measures the fuel level in the tank. The red indicator in the window will reference the level in relation to full or empty. To provide increased operating time, start with a full tank before beginning operation. Check the fuel level with the generator on a level surface. Always refuel with the engine OFF and cool.

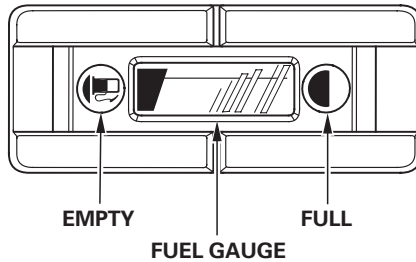
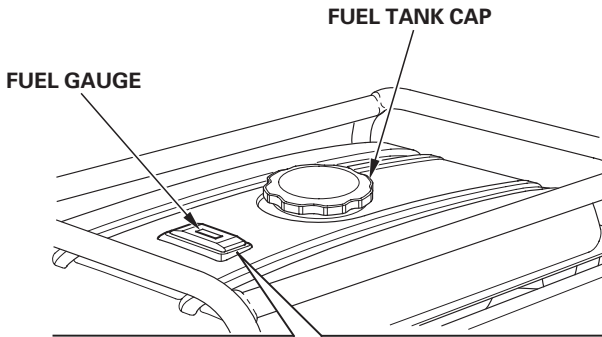

BEFORE OPERATION

ARE YOU READY TO GET STARTED?

Your safety is your responsibility. A little time spent in preparation will significantly reduce your risk of injury.

Knowledge

Read and understand this manual. Know what the controls do and how to operate them.

Familiarize yourself with the generator and its operation before you begin using it. Know how to quickly shut off the generator in case of an emergency.

If the generator is being used to power appliances, be sure that they do not exceed the generator's load rating (see page 24).

IS YOUR GENERATOR READY TO GO?

For your safety, and to maximize the service life of your equipment, it is very important to take a few moments before you operate the generator to check its condition. Be sure to take care of any problem you find, or have your servicing dealer correct it, before you operate the generator.

⚠ WARNING

Improperly maintaining this generator, or failing to correct a problem before operation, could cause a malfunction in which you could be seriously injured.

Always perform a pre-operation inspection before each operation, and correct any problem.

BEFORE OPERATION

To prevent a possible fire, keep the generator at least 3 feet (1 meter) away from building walls and other equipment during operation. Do not place flammable objects close to the engine.

Before beginning your preoperation checks, be sure the generator is on a level surface and the engine switch is in the OFF position.

NOTICE

Operating this generator less than 3 feet (1 meter) from a building or other obstruction can cause overheating and damage the generator. For proper cooling, allow at least 3 feet (1 meter) of empty space above and around the generator.

Check the Engine

Check the oil level (see page 32). A low oil level will cause the Oil Alert system to shut down the engine.

Check the air filter (see page 35). A dirty air filter will restrict air flow to the carburetor, reducing engine and generator performance.

Check the fuel level (see page 30). Starting with a full tank will help to eliminate or reduce operating interruptions for refueling.

OPERATION

SAFE OPERATING PRECAUTIONS

Before operating the generator for the first time, please review the *GENERATOR SAFETY* section and the chapter titled *BEFORE OPERATION*.

For your safety, do not operate the generator in an enclosed area such as a garage. Your generator's exhaust contains poisonous carbon monoxide gas that can collect rapidly in an enclosed area and cause illness or death.

WARNING

Exhaust contains poisonous carbon monoxide gas that can build up to dangerous levels in closed areas. Breathing carbon monoxide can cause unconsciousness or death.

Never run the generator in a closed, or even partly closed area where people may be present.

To prevent a possible fire, keep the generator at least 3 feet (1 meter) away from building walls and other equipment during operation. Do not place flammable objects close to the engine.

NOTICE

Operating this generator less than 3 feet (1 meter) from a building or other obstruction can cause overheating and damage the generator. For proper cooling, allow at least 3 feet (1 meter) of empty space above and around the generator.

Before connecting an AC appliance or power cord to the generator:

- Use grounded 3-prong extension cords, tools, and appliances, or double-insulated tools and appliances.
- Inspect cords and plugs, and replace if damaged.
- Make sure that the appliance is in good working order. Faulty appliances or power cords can create a potential for electric shock.
- Make sure the electrical rating of the tool or appliance does not exceed that of the generator. Never exceed the maximum power rating of the generator. Power levels between rated and maximum may be used for no more than 30 minutes.
- Operate the generator at least 3 feet (1 meter) away from buildings and other equipment.
- Do not operate the generator in an enclosed structure.

OPERATION

STARTING THE ENGINE

Refer to *SAFE OPERATING PRECAUTIONS* on page 18 and perform the *IS YOUR GENERATOR READY TO GO* checks (see page 16).

Refer to *AC Operation* (see page 23) for connecting loads to the generator.

1. Make sure that the AC circuit breaker is in the OFF position. The generator may be hard to start if a load is connected.

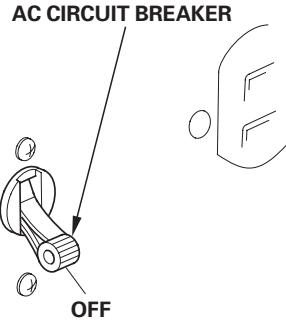

2. Turn the fuel valve lever to the ON position.

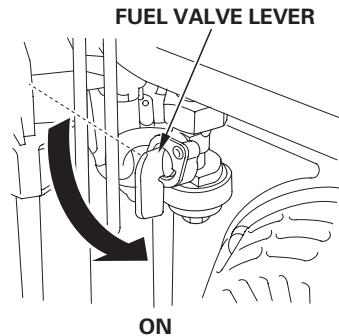

3. Move the choke lever to the CLOSED position to start a cold engine.

Leave the choke lever in the OPEN position to restart a warm engine.

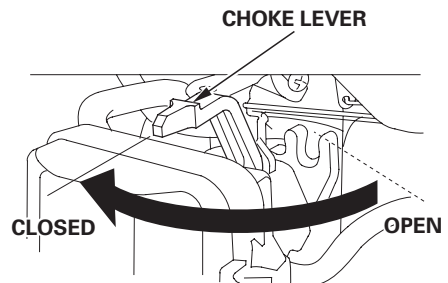

4. Turn the engine switch to the ON position.

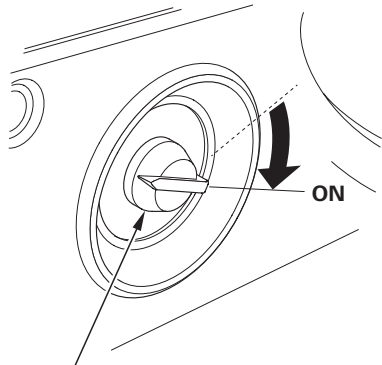

ENGINE SWITCH

5. Pull the starter grip lightly until you feel resistance, then pull briskly in the direction of the arrow as shown.

NOTICE

- Do not allow the starter grip to snap back against the engine. Return it gently to prevent damage to the starter.
- Do not let the starter rope rub against the generator body, or the rope will wear out prematurely.

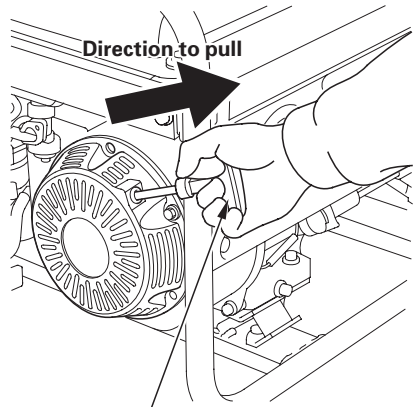

STARTER GRIP

6. If the choke lever was moved to the CLOSED position to start the engine, gradually move it to the OPEN position as the engine warms up.

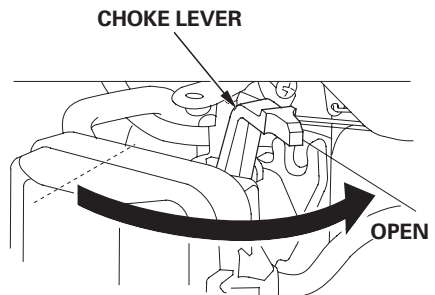

CHOKE LEVER

OPERATION

STOPPING THE ENGINE

To stop the engine in an emergency, simply turn the engine switch to the OFF position. Under normal conditions, use the following procedure.

1. Move the AC circuit breaker to the OFF position.

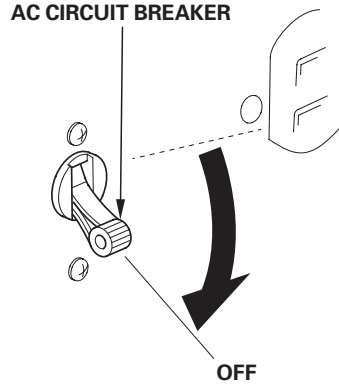

2. Turn the engine switch to the OFF position.

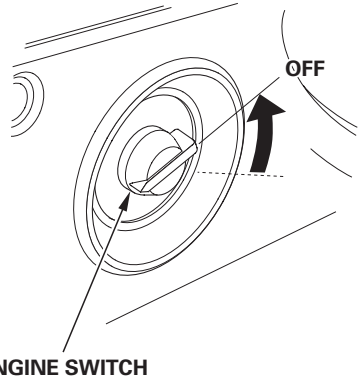

3. Turn the fuel valve lever to the OFF position.

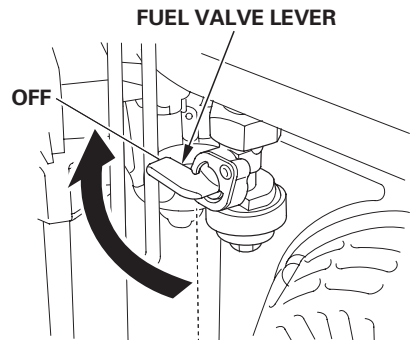

AC OPERATION

If an appliance begins to operate abnormally, becomes sluggish, or stops suddenly, turn it off immediately. Disconnect the appliance, and determine whether the problem is in the appliance or the rated load capacity of the generator has been exceeded.

NOTICE

Substantial overloading may damage the generator. Marginal overloading may shorten the service life of the generator.

1. Start the engine (see page 20).
2. Switch ON the AC circuit breaker.
3. Plug in the appliance.
Most motorized appliances require more than their rated wattage for startup.

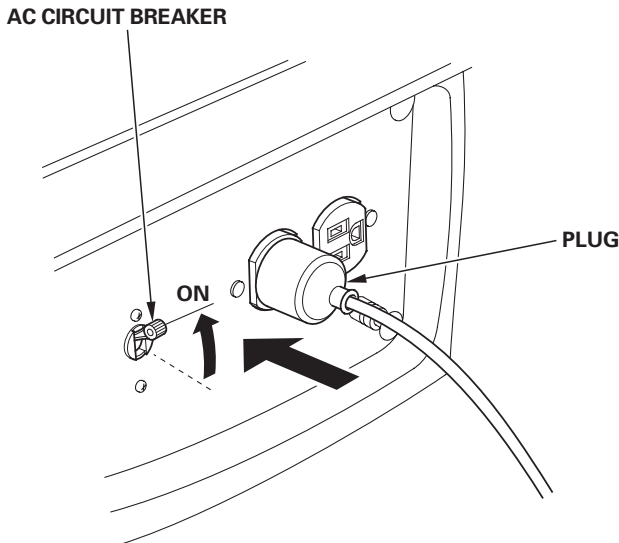

OPERATION

AC Applications

Before connecting an appliance or power cord to the generator:

- Make sure that it is in good working order. Faulty appliances or power cords can create a potential for electrical shock.
- If an appliance begins to operate abnormally, becomes sluggish, or stops suddenly, turn it off immediately. Disconnect the appliance, and determine whether the problem is the appliance or the rated load capacity of the generator has been exceeded.
- Make sure that the electrical rating of the tool or appliance does not exceed that of the generator. Never exceed the maximum power rating of the generator. Power levels between rated and maximum may be used for no more than 30 minutes.

NOTICE

Substantial overloading will open the circuit breaker. Exceeding the time limit for maximum power operation or slightly overloading the generator may not switch the circuit breaker OFF, but will shorten the service life of the generator.

Limit operation requiring maximum power to 30 minutes.
Maximum power is: 2,500 VA

For continuous operation (longer than 30 minutes), do not exceed the rated power.
Rated power is: 2,300 VA

The total power requirements (VA) of all appliances connected must be considered. Appliance and power tool manufacturers usually list rating information near the model number or serial number.

STANDBY POWER

Connections to a Building's Electrical System

Your generator can supply power to a building's electrical system. If the generator will be used as an alternative to utility company power, an isolation switch must be installed to disconnect the utility lines from the building when the generator is connected. Installation must be performed by a qualified electrician and must comply with all applicable laws and electrical codes.

⚠ WARNING

Improper connections to a building's electrical system can allow current from the generator to backfeed into the utility lines.

Such backfeed may electrocute utility company workers or others who contact the lines during a power outage, and the generator may explode, burn, or cause fires when utility power is restored.

Consult the utility company or a qualified electrician prior to making any power connections.

In some areas, generators are required by law to be registered with local utility companies. Check local regulations for proper registration and use procedures.

System Ground

Honda portable generators have a system ground that connects the generator frame components to the ground terminals in the AC output receptacles. The system ground is not connected to the AC neutral wire. If the generator is tested with a receptacle tester, it will not show the same ground circuit condition as for a home receptacle.

OPERATION

Special Requirements

There may be Federal or State Occupational Safety and Health Administration (OSHA) regulations, local codes, or ordinances that apply to the intended use of the generator. Please consult a qualified electrician, electrical inspector, or the local agency having jurisdiction.

- In some areas, generators are required to be registered with local utility companies.
- If the generator is used at a construction site, there may be additional regulations that must be observed.

SERVICING YOUR GENERATOR

THE IMPORTANCE OF MAINTENANCE

Good maintenance is essential for safe, economical, and trouble-free operation. It will also help reduce air pollution.

To help you properly care for your generator, the following pages include a maintenance schedule, routine inspection procedures, and simple maintenance procedures using basic hand tools. Other service tasks that are more difficult or require special tools are best handled by professionals and are normally performed by a Honda technician or other qualified mechanic.

The maintenance schedule applies to normal operating conditions. If you operate your generator under unusual conditions, such as sustained high-load or high-temperature operation, or use it in dusty conditions, consult your servicing dealer for recommendations applicable to your individual needs and use.

WARNING

Improper maintenance, or failure to correct a problem before operation, can cause a malfunction in which you can be seriously hurt or killed.

Always follow the inspection and maintenance recommendations and schedules in this owner's manual.

Remember that your servicing dealer knows your generator best and is fully equipped to maintain and repair it.

To ensure the best quality and reliability, use only new, Honda Genuine parts or their equivalents for repair and replacement.

Maintenance, replacement, or repair of the emission control devices and systems may be performed by any engine repair establishment or individual, using parts that are "certified" to EPA standards.

SERVICING YOUR GENERATOR

MAINTENANCE SAFETY

Some of the most important safety precautions follow. However, we cannot warn you of every conceivable hazard that can arise in performing maintenance. Only you can decide whether or not you should perform a given task.

WARNING

Failure to properly follow maintenance instructions and precautions can cause you to be seriously hurt or killed.

Always follow the procedures and precautions in the owner's manual.

Safety Precautions

Make sure the engine is off before you begin any maintenance or repairs. This will eliminate several potential hazards:

- **Carbon monoxide poisoning from engine exhaust.**
Operate outside away from open windows or doors.
- **Burns from hot parts.**
Let the engine and exhaust system cool before touching.
- **Injury from moving parts.**
Do not run the engine unless instructed to do so.
- Read the instructions before you begin, and make sure you have the tools and skills required.
- To reduce the possibility of fire or explosion, be careful when working around gasoline. Use only a non-flammable solvent, not gasoline, to clean parts. Keep cigarettes, sparks, and flames away from all fuel-related parts.

SERVICING YOUR GENERATOR

MAINTENANCE SCHEDULE

REGULAR SERVICE PERIOD (3) Perform at every indicated month or operating hour interval, whichever comes first.		Each use	First month or 20 Hrs.	Every 3 months or 50 Hrs.	Every 6 months or 100 Hrs.	Every year or 300 Hrs.	Page
ITEM							
Engine oil	Check level	○					32
	Change		○		○		33
Air cleaner	Check	○					35
	Clean			○ (1)			37
Canister (California type)	Check	Every 2 years (2)					—
Purge tube (California type)	Check	Every 2 years (2)					—
Charge tube (California type)	Check	Every 2 years (2)					—
Sediment cup	Clean				○		38
Spark plug	Check-adjust				○		39
	Replace					○	39
Spark arrester (equipped type only)	Clean				○		41
Valve clearance	Check-adjust					○ (2)	—
Combustion chamber	Clean	After every 500 Hrs. (2)					—
Fuel tank and filter	Clean					○ (2)	—
Fuel tube	Check	Every 2 years (Replace if necessary) (2)					—

(1) Service more frequently when used in dusty areas.

(2) These items should be serviced by your Honda servicing dealer, unless you have the proper tools and are mechanically proficient. Refer to the Honda shop manual for service procedures.

(3) For commercial use, log hours of operation to determine proper maintenance intervals.

Failure to follow this maintenance schedule could result in non-warrantable failures.

SERVICING YOUR GENERATOR

REFUELING

With the engine stopped, check the fuel gauge. Refill the fuel tank if the fuel level is low.

WARNING

Gasoline is highly flammable and explosive.

You can be burned or seriously injured when handling fuel.

- Stop the engine and keep heat, sparks, and flame away.
- Handle fuel only outdoors.
- Wipe up spills immediately.

NOTICE

Fuel can damage paint and plastic. Be careful not to spill fuel when filling your fuel tank. Damage caused by spilled fuel is not covered under warranty.

Refuel in a well-ventilated area before starting the engine. If the engine has been running, allow it to cool. Refuel carefully to avoid spilling fuel. Do not fill the fuel tank above the upper limit mark on the fuel strainer. Never refuel the engine inside a building where gasoline fumes may reach flames or sparks. Keep gasoline away from appliance pilot lights, barbecues, electric appliances, power tools, etc. Spilled fuel is not only a fire hazard, it causes environmental damage. Wipe up spills immediately.

SERVICING YOUR GENERATOR

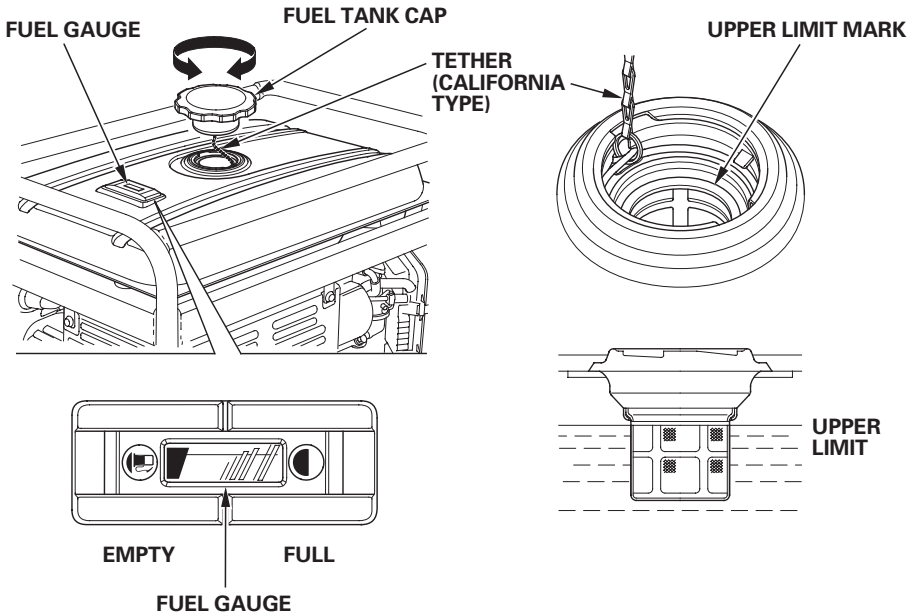

After refueling, reinstall the fuel tank cap securely.

FUEL RECOMMENDATIONS

This engine is certified to operate on regular unleaded gasoline with a pump octane rating of 86 or higher.

Never use stale or contaminated gasoline or an oil/gasoline mixture. Avoid getting dirt or water in the fuel tank.

You may use regular unleaded gasoline containing no more than 10% ethanol (E10) or 5% methanol by volume. In addition, methanol must contain cosolvents and corrosion inhibitors.

Use of fuels with content of ethanol or methanol greater than shown above may cause starting and/or performance problems. It may also damage metal, rubber, and plastic parts of the fuel system.

Engine damage or performance problems that result from using a fuel with percentages of ethanol or methanol greater than shown above are not covered under warranty.

If your equipment will be used on an infrequent or intermittent basis, please refer to the fuel section of the *STORAGE* chapter (page 43) for additional information regarding fuel deterioration.

SERVICING YOUR GENERATOR

ENGINE OIL LEVEL CHECK

Check the engine oil level with the generator on a level surface and the engine stopped.

1. Remove the oil filler cap/dipstick and wipe it clean.
2. Insert and remove the dipstick without screwing it into the oil filler hole. Check the oil level shown on the dipstick.
3. If the oil level is low, fill to the outer edge of the oil filler hole with the recommended oil (see page 34).
4. Screw in the oil filler cap/dipstick securely.

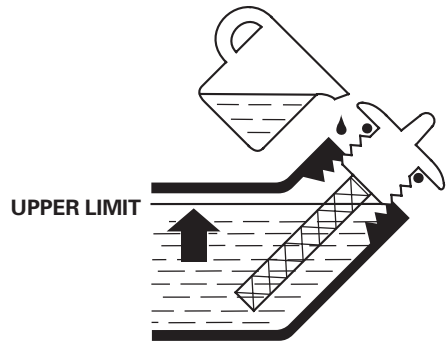
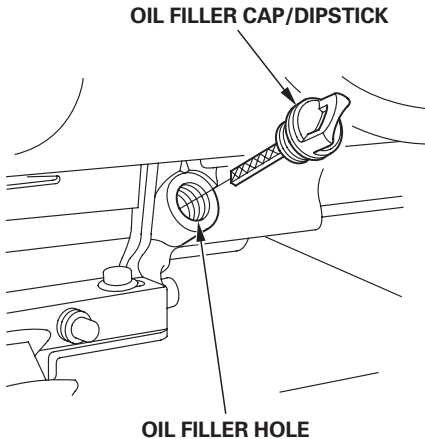

The Oil Alert system will automatically stop the engine before the oil level falls below safe limits. However, to avoid the inconvenience of an unexpected shutdown, check the oil level regularly.

SERVICING YOUR GENERATOR

ENGINE OIL CHANGE

Drain the oil while the engine is warm to assure rapid and complete draining.

1. Place a suitable container below the engine to catch the used oil, and then remove the oil filler cap/dipstick, drain plug, and sealing washer.
2. Allow the used oil to drain completely, and then reinstall the drain plug and a new sealing washer. Tighten the plug securely.

NOTICE

Improper disposal of engine oil can be harmful to the environment. If you change your own oil, please dispose of the used oil properly. Put it in a sealed container, and take it to a recycling center. Do not discard it in a trash bin, dump it on the ground, or pour it down the drain.

3. With the generator in a level position, fill with the recommended oil (see page 34) to the outer edge of the oil filler hole.
4. Screw in the oil filler cap/dipstick securely.

Wash your hands with soap and water after handling used oil.

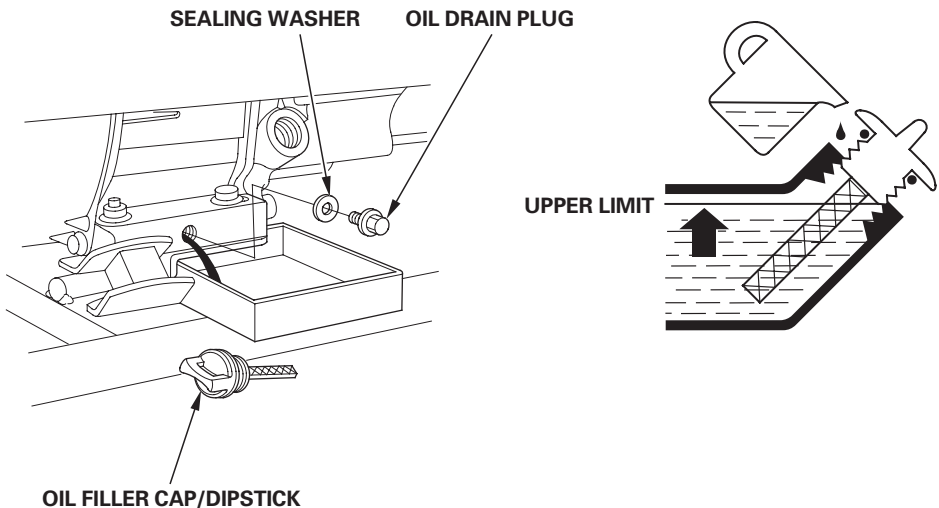

SERVICING YOUR GENERATOR

ENGINE OIL RECOMMENDATIONS

Oil is a major factor affecting engine performance and service life.

Use 4-stroke motor oil that meets or exceeds the requirements for API service category SJ or later (or equivalent). Always check the API SERVICE label on the oil container to be sure it includes the letters SJ or later (or equivalent).

SAE 10W-30 is recommended for general use. Other viscosities shown in the chart may be used when the average temperature in your area is within the indicated range.

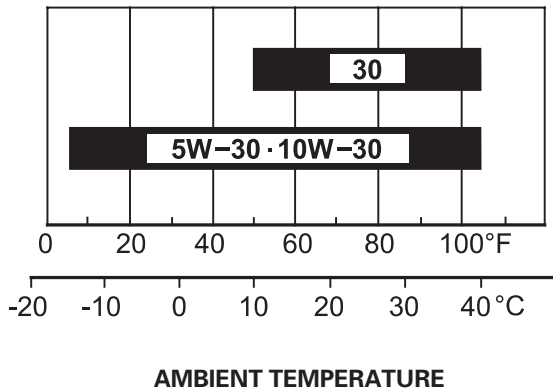

SERVICING YOUR GENERATOR

AIR CLEANER SERVICE

1. Push the latch tabs and open the air cleaner cover.
2. Free the hooks from the setting pins on the air cleaner case and remove the air cleaner cover to the right side of the frame pipe, taking care not to damage the air cleaner cover.
3. Remove the foam air filter from the air cleaner case.
4. Check the foam air filter to be sure it is clean and in good condition. If the foam air filter is dirty, clean it as described on page 37. Replace the foam air filter if it is damaged.

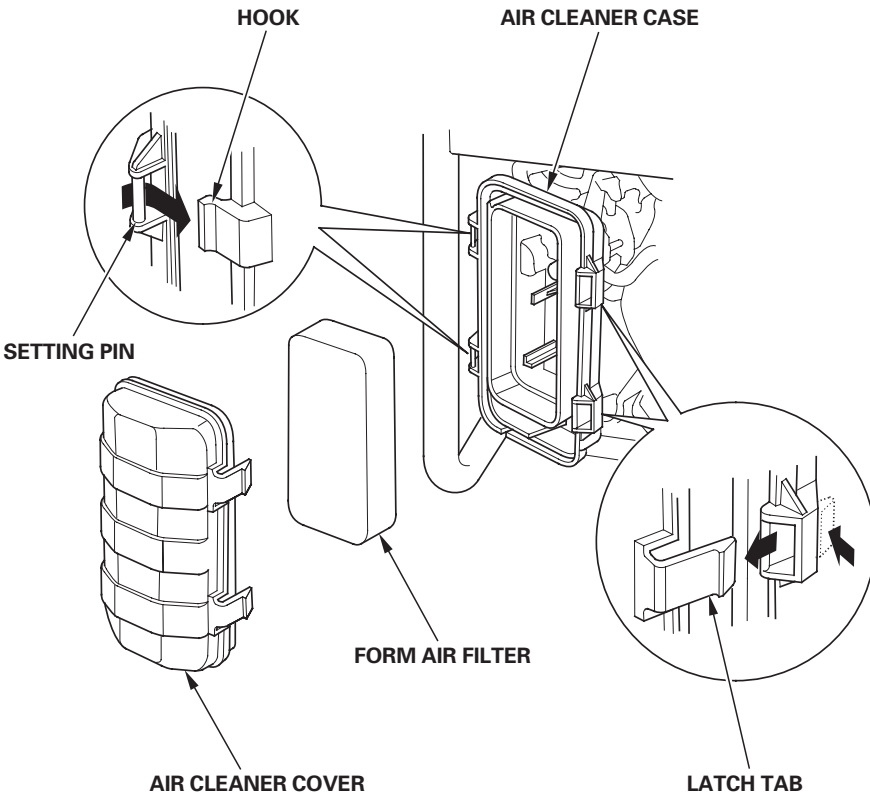

SERVICING YOUR GENERATOR

5. Reinstall the foam air filter in the air cleaner case.
6. Set the hooks of the air cleaner cover to the setting pins securely, then push the air cleaner cover to lock the latch tabs. Be sure that the cover is set securely. There must be no clearance between the air cleaner cover and case.

NOTICE

Operating the engine without an air filter or with a damaged air filter will allow dirt to enter the engine, causing rapid engine wear. This type of damage is not covered by the Distributor's Limited Warranty.

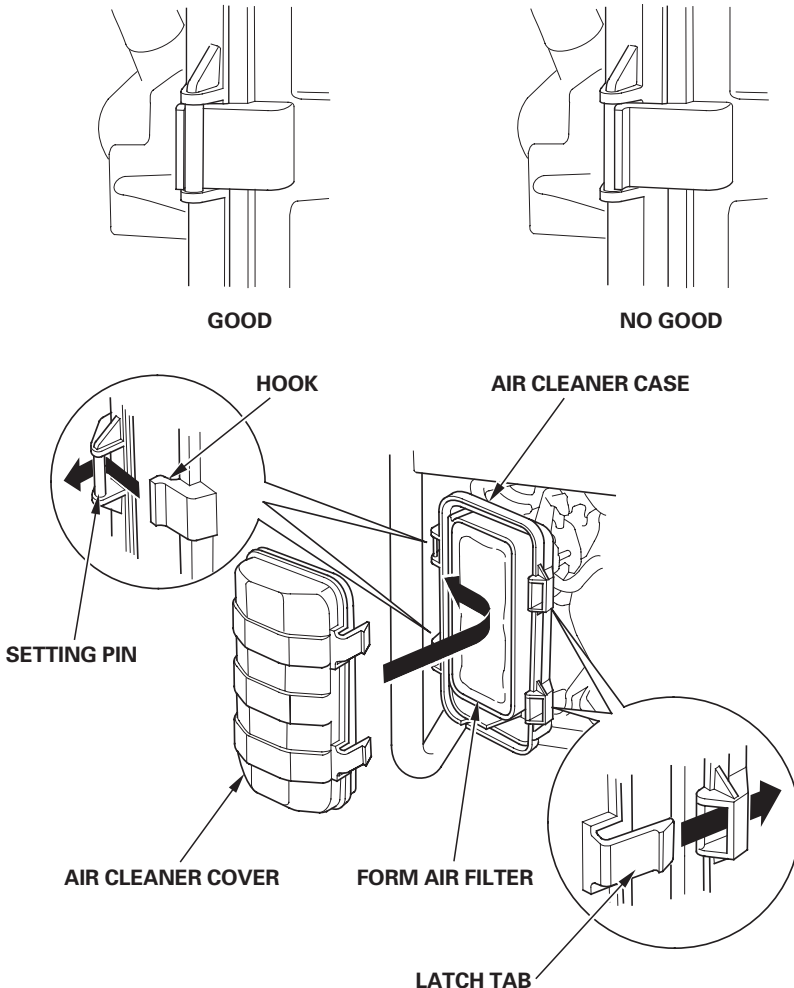

SERVICING YOUR GENERATOR

FOAM AIR FILTER CLEANING

A dirty foam air filter will restrict air flow to the carburetor, reducing engine performance. If you operate the generator in very dusty areas, clean the foam air filter more frequently than specified in the Maintenance Schedule.

1. Clean the foam air filter in warm soapy water, rinse, and allow to dry thoroughly, or clean in non-flammable solvent and allow to dry.
2. Dip the foam air filter in clean engine oil, and then squeeze out all excess oil. The engine will smoke when started if too much oil is left in the filter.

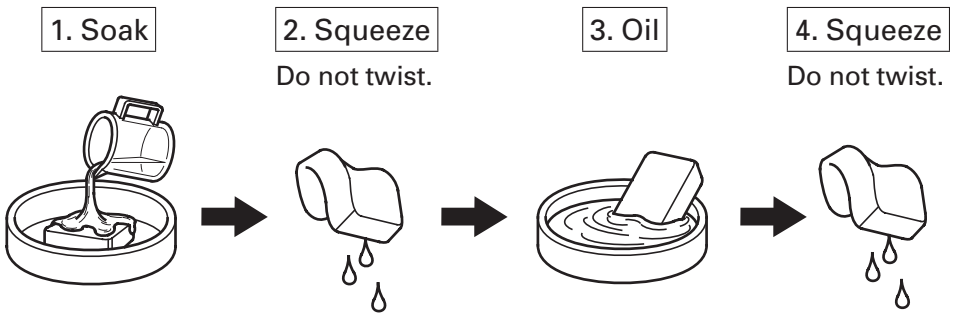

3. Wipe dirt from the air cleaner housing and cover using a moist rag. Be careful to prevent dirt from entering the air duct that leads to the carburetor.

SERVICING YOUR GENERATOR

SEDIMENT CUP CLEANING

1. Turn the fuel valve lever to the OFF position, then remove the sediment cup, O-ring, and filter. Discard the O-ring.

⚠ WARNING

Gasoline is highly flammable and explosive.

You can be burned or seriously injured when handling fuel.

- Stop the engine and keep heat, sparks, and flame away.
- Handle fuel only outdoors.
- Wipe up spills immediately.

2. Clean the sediment cup and filter in nonflammable solvent, and dry them thoroughly.
3. Reinstall the filter, new O-ring, and sediment cup, and tighten the sediment cup securely.
4. Turn the fuel valve lever to the ON position and check for leaks.

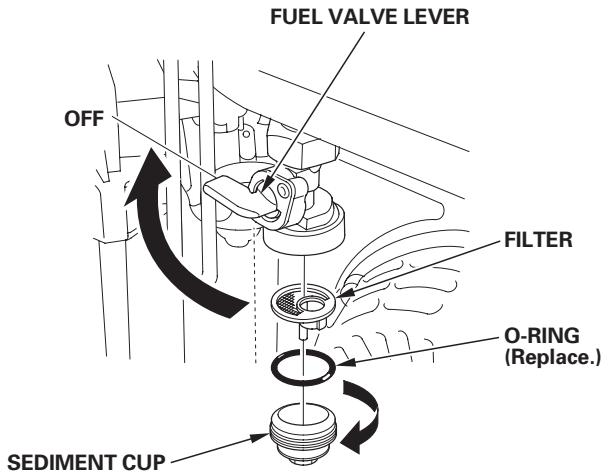

SERVICING YOUR GENERATOR

SPARK PLUG SERVICE

Recommended spark plugs: BPR6ES (NGK)
W20EPR-U (DENSO)

NOTICE

An incorrect spark plug can cause engine damage.

If the engine is hot, allow it to cool before servicing the spark plug.

1. Disconnect the spark plug cap, and remove any dirt from around the spark plug area.
2. Remove the spark plugs with a spark plug wrench.

SPARK PLUG WRENCH

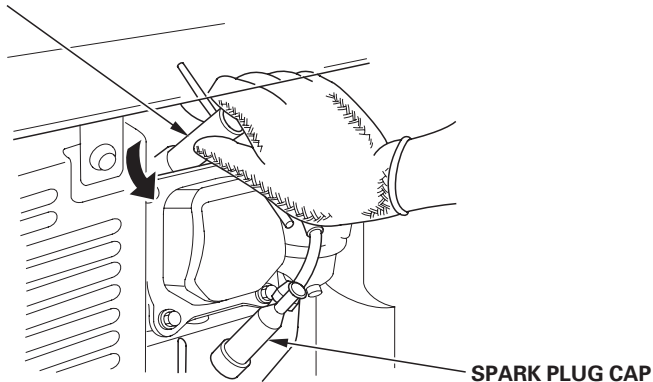

3. Inspect the spark plug. Replace it if the electrodes are worn or if the insulator is cracked, chipped, or fouled.
4. Measure the spark plug electrode gap with a wire-type feeler gauge. Correct the gap, if necessary, by carefully bending the side electrode.

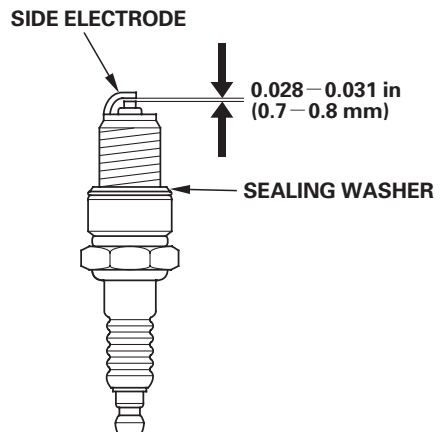

The gap should be:
0.028–0.031 in (0.7–0.8 mm)

SERVICING YOUR GENERATOR

5. Make sure that the spark plug sealing washer is in good condition, and thread the spark plug in by hand to prevent cross-threading.
6. After the spark plug seats, tighten with a 13/16-inch spark plug wrench to compress the washer.

If reinstalling a used spark plug, tighten 1/8 – 1/4 turn after the spark plug seats.

If installing a new spark plug, tighten 1/2 turn after the spark plug seats.

NOTICE

*A loose spark plug can overheat and damage the engine.
Overtightening the spark plug can damage the threads in the cylinder head.*

7. Attach the spark plug cap.

SERVICING YOUR GENERATOR

SPARK ARRESTER SERVICE

The spark arrester must be serviced every 100 hours to keep it functioning as designed.

If the engine has been running, the muffler will be very hot. Allow the muffler to cool before servicing the spark arrester.

1. Remove the 4 mm screw, then pull out the spark arrester.

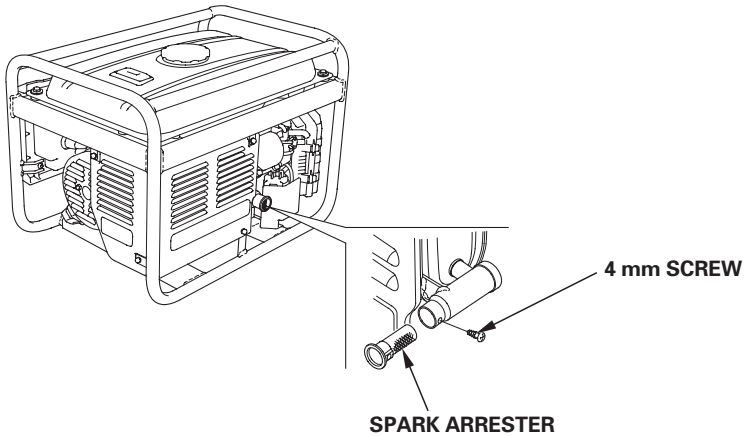

2. Use a brush to remove carbon deposits from the spark arrester screen.
Be careful to avoid damaging the screen.
The spark arrester must be free of breaks and tears. Replace the spark arrester if it is damaged.



SERVICING YOUR GENERATOR

3. Reinsert the spark arrester, tighten the 4 mm screw to reinstall it.

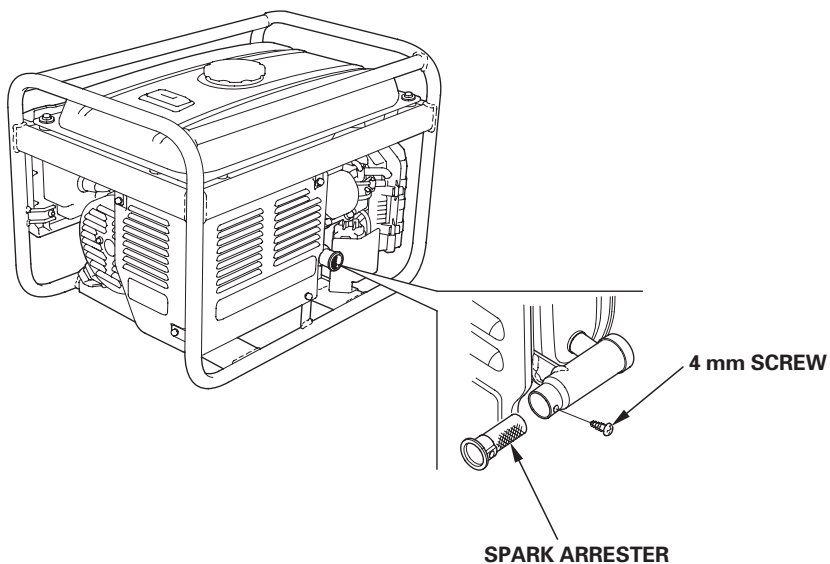

STORAGE

STORAGE PREPARATION

Proper storage preparation is essential for keeping your generator trouble-free and looking good. The following steps will help to keep rust and corrosion from impairing your generator's function and appearance, and will make the engine easier to start when you use the generator again.

Cleaning

Wipe the generator with a moist cloth. After the generator has dried, touch up any damaged paint, and coat other areas that may rust with a light film of oil.

Fuel

NOTICE

Depending on the region where you operate your equipment, fuel formulations may deteriorate and oxidize rapidly. Fuel deterioration and oxidation can occur in as little as 30 days and may cause damage to the carburetor and/or fuel system. Please check with your servicing dealer for local storage recommendations.

Gasoline will oxidize and deteriorate in storage. Old gasoline will cause hard starting, and it leaves gum deposits that clog the fuel system. If the gasoline in your generator deteriorates during storage, you may need to have the carburetor and other fuel system components serviced or replaced.

The length of time that gasoline can be left in your fuel tank and carburetor without causing functional problems will vary with such factors as gasoline blend, your storage temperatures, and whether the fuel tank is partially or completely filled. The air in a partially filled fuel tank promotes fuel deterioration. Very warm storage temperatures accelerate fuel deterioration. Fuel deterioration problems may occur within a few months, or even less if the gasoline was not fresh when you filled the fuel tank.

The *Distributor's Limited Warranty* does not cover fuel system damage or engine performance problems resulting from neglected storage preparation.

You can extend fuel storage life by adding a gasoline stabilizer that is formulated for that purpose, or you can avoid fuel deterioration problems by draining the carburetor, sediment cup (if applicable) and/or fuel tank.

STORAGE

Service according to the table below:

STORAGE TIME	RECOMMENDED SERVICE PROCEDURE TO PREVENT HARD STARTING
Less than 1 month	No preparation required
1 to 2 months	Fill with fresh gasoline and add gasoline stabilizer *.
2 months to 1 year	Fill with fresh gasoline and add gasoline stabilizer *. Drain the carburetor float bowl (page 45). Drain the fuel sediment cup (page 38).
1 year or more	Fill with fresh gasoline and add gasoline stabilizer *. Drain the carburetor float bowl (page 45). Drain the fuel sediment cup (page 38). Remove the spark plug. Put a teaspoon of engine oil into the cylinder. Turn the engine slowly with the pull rope to distribute the oil. Reinstall the spark plug. Change the engine oil (page 33). After removal from storage, drain the stored gasoline into a suitable container, and fill with fresh gasoline before starting.
<p>*Use gasoline stabilizers that are formulated to extend storage life. Follow the manufacturer's instructions for use. Contact your authorized Honda generator dealer for stabilizer recommendations.</p>	

Draining the Fuel Tank and Carburetor

⚠ WARNING

Gasoline is highly flammable and explosive.

You can be burned or seriously injured when handling fuel.

- Stop the engine and keep heat, sparks, and flame away.
- Handle fuel only outdoors.
- Wipe up spills immediately.

1. Non-california type:

Place a suitable gasoline container below the carburetor, and use a funnel to avoid spilling fuel.

California type:

Place a suitable gasoline container below the carburetor drain hose.

2. Non-california type:

Remove the drain bolt and sealing washer and drain the gasoline from the carburetor.

California type:

Loosen the carburetor drain screw and drain the gasoline from the carburetor.

NON-CALIFORNIA TYPE

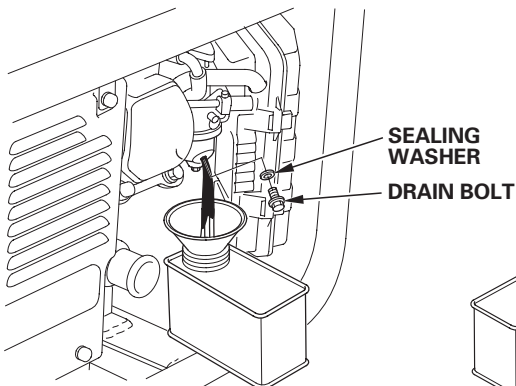

CALIFORNIA TYPE

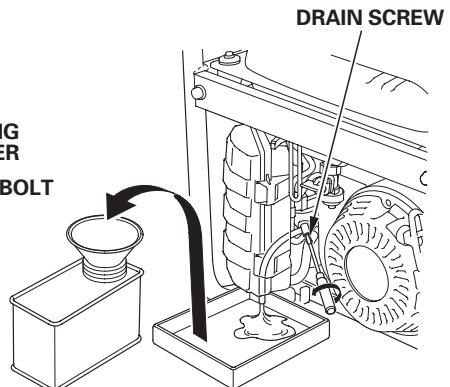

STORAGE

3. Non-california type:

After all the gasoline has drained into the container, tighten the drain bolt securely.

California type:

After all the gasoline has drained into the container, tighten the drain screw securely.

4. Place a suitable gasoline container below the sediment cup, and use a funnel to avoid spilling gasoline.
5. Remove the sediment cup (see page 38), and then turn the fuel valve lever to the ON position.
6. Allow the gasoline to drain completely, and then install the sediment cup (see page 38).

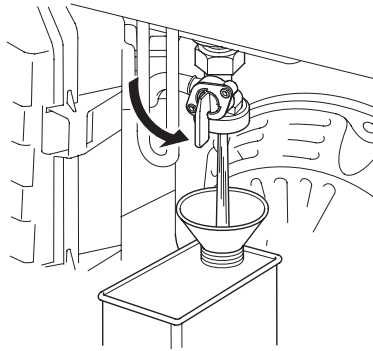

Engine Oil

1. Change the engine oil (see page 33).
2. Remove the spark plug (see page 39).
3. Pour a teaspoon (5 – 10 cc) of clean engine oil into the cylinder.
4. Pull the starter grip several times to distribute the oil in the cylinder.
5. Reinstall the spark plug.
6. Slowly pull the starter grip until resistance is felt. At this point, the piston is coming up on its compression stroke and both the intake and exhaust valves are closed. Storing the engine in this position will help to protect it from internal corrosion. Return the starter grip gently.

STORAGE PRECAUTIONS

If your generator will be stored with gasoline in the fuel tank and carburetor, it is important to reduce the hazard of gasoline vapor ignition.

Select a well ventilated storage area away from any appliance that operates with a flame, such as a furnace, water heater, or clothes dryer. Also avoid any area with a spark-producing electric motor, or where power tools are operated.

If possible, avoid storage areas with high humidity, because that promotes rust and corrosion.

Unless all fuel has been drained from the fuel tank, leave the fuel valve in the OFF position to reduce the possibility of leakage.

Place the generator on a level surface. Tilting can cause fuel or oil leakage.

With the engine and exhaust system cool, cover the generator to keep out dust. A hot engine and exhaust system can ignite or melt some materials.

Do not use sheet plastic as a dust cover. A nonporous cover will trap moisture around the generator, promoting rust and corrosion.

REMOVAL FROM STORAGE

Check your generator as described in the *BEFORE OPERATION* chapter of this manual.

If the fuel was drained during storage preparation, fill the tank with fresh gasoline. If you keep a container of gasoline for refueling, be sure that it contains only fresh gasoline. Gasoline oxidizes and deteriorates over time, causing hard starting.

If the cylinder was coated with oil during storage preparation, the engine may smoke briefly at startup. This is normal.

TRANSPORTING

If the generator has been running, allow the engine to cool for at least 15 minutes before loading the generator on the transport vehicle. A hot engine and exhaust system can burn you and can ignite some materials.

Keep the generator level when transporting to reduce the possibility of fuel leakage. Move the fuel valve lever to the OFF position.

When using ropes or tie-down straps to secure the generator for transportation, be sure to only use the frame bars as attachment points. Do not fasten ropes or straps to any portions of the generator body.

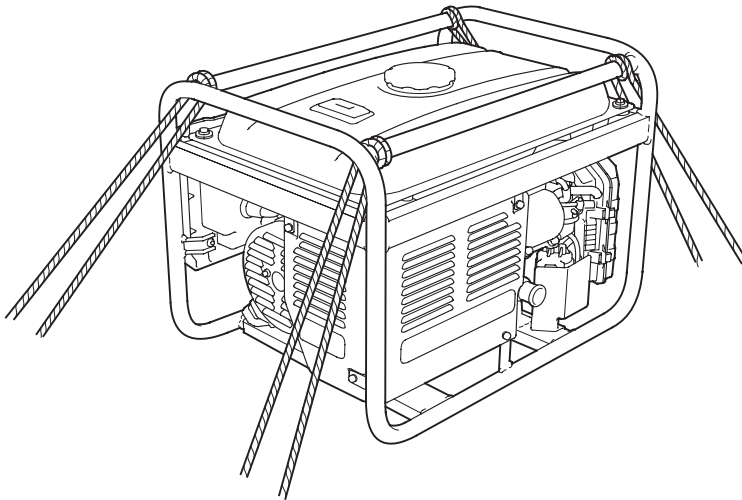

TAKING CARE OF UNEXPECTED PROBLEMS

ENGINE WILL NOT START

Possible Cause	Correction
Fuel valve lever OFF.	Turn lever ON.
Choke OPEN.	Move to CLOSED unless engine is warm.
Engine switch OFF.	Turn engine switch to ON.
Out of fuel.	Refuel (p. 30).
Bad fuel; generator stored without treating or draining gasoline, or refueled with bad gasoline.	Drain fuel tank and carburetor (p. 45). Refuel with fresh gasoline (p. 30).
Low oil level caused Oil Alert to stop engine.	Add oil (p. 32). Turn engine switch to OFF and restart the engine.
Spark plug faulty, fouled, or improperly gapped.	Gap or replace spark plug (p. 39).
Spark plug wet with fuel (flooded engine).	Dry and reinstall spark plug.
Fuel filter restricted, carburetor malfunction, ignition malfunction, valves stuck, etc.	Take the generator to an authorized Honda servicing dealer, or refer to the shop manual.

TAKING CARE OF UNEXPECTED PROBLEMS

ENGINE LACKS POWER

Possible cause	Correction
Air filter restricted.	Clean or replace air filter (p. 35 thru. 37).
Bad fuel; generator stored without treating or draining gasoline, or refueled with bad gasoline.	Drain fuel tank and carburetor (p. 45). Refuel with fresh gasoline (p. 30).
Fuel filter restricted, carburetor malfunction, ignition malfunction, valves stuck, etc.	Take the generator to an authorized Honda servicing dealer, or refer to the shop manual.

TAKING CARE OF UNEXPECTED PROBLEMS

NO POWER AT THE RECEPTACLES

Possible Cause	Correction
Circuit breaker left in the OFF position after starting.	Switch circuit breaker ON.
Faulty power tool or appliance.	Replace or repair power tool or appliance. Stop and restart the engine.
Faulty generator.	Take the generator to an authorized Honda servicing dealer, or refer to the shop manual.

TECHNICAL & CONSUMER INFORMATION

TECHNICAL INFORMATION

Serial Number Location

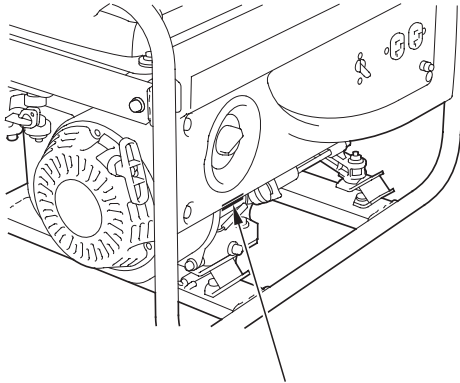

ENGINE SERIAL NUMBER

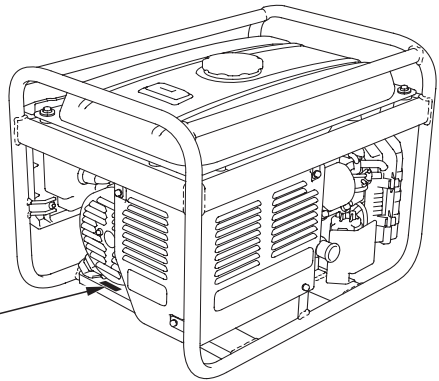

FRAME SERIAL NUMBER

Record the engine and frame serial numbers and date purchased in the spaces below. You will need this information when ordering parts and when making technical or warranty inquiries.

Engine serial number: _____

Frame serial number: _____

Date purchased: _____

Carburetor Modification for High Altitude Operation

At high altitude, the standard carburetor air-fuel mixture will be too rich. Performance will decrease, and fuel consumption will increase. A very rich mixture will also foul the spark plug and cause hard starting. Operation at an altitude that differs from that at which this engine was certified, for extended periods of time, may increase emissions.

High altitude performance can be improved by specific modifications to the carburetor. If you always operate your generator at altitudes above 5,000 feet (1,500 meters), have your authorized Honda servicing dealer perform this carburetor modification. This engine, when operated at high altitude with the carburetor modifications for high altitude use, will meet each emission standard throughout its useful life.

Even with carburetor modification, engine horsepower will decrease about 3.5% for each 1,000-foot (300-meter) increase in altitude. The effect of altitude on horsepower will be greater than this if no carburetor modification is made.

NOTICE

When the carburetor has been modified for high altitude operation, the air/fuel mixture will be too lean for low altitude use. Operation at altitudes below 5,000 feet (1,500 meters) with a modified carburetor may cause the engine to overheat and result in serious engine damage. For use at low altitudes, have your servicing dealer return the carburetor to original factory specifications.

TECHNICAL & CONSUMER INFORMATION

Emission Control System Information

Source of Emissions

The combustion process produces carbon monoxide, oxides of nitrogen, and hydrocarbons. Control of hydrocarbons and oxides of nitrogen is very important because, under certain conditions, they react to form photochemical smog when subjected to sunlight. Carbon monoxide does not react in the same way, but it is toxic.

Honda utilizes appropriate air/fuel ratios and other emissions control systems to reduce the emissions of carbon monoxide, oxides of nitrogen, and hydrocarbons.

Additionally, Honda fuel systems utilize components and control technologies to reduce evaporative emissions.

The U.S. and California Clean Air Acts

EPA and California regulations require all manufacturers to furnish written instructions describing the operation and maintenance of emission control systems.

The following instructions and procedures must be followed in order to keep the Honda engine emissions within the emission standards.

Tampering and Altering

Tampering with or altering the emission control system may increase emissions beyond the legal limit. Among those acts that constitute tampering are:

- Removal or alteration of any part of intake, fuel, or exhaust systems.
- Altering or defeating the governor linkage or speed-adjusting mechanism to cause the engine to operate outside its design parameters.

Problems That May Affect Emissions

If you are aware of any of the following symptoms, have your engine inspected and repaired by your authorized Honda servicing dealer.

- Hard starting or stalling after starting.
- Rough idle.
- Misfiring or backfiring under load.
- Afterburning (backfiring).
- Black exhaust smoke or high fuel consumption.

Replacement Parts

The emission control systems on your new Honda engine were designed, built, and certified to conform with applicable emission regulations. We recommend the use of Honda Genuine parts whenever you have maintenance done. These original-design replacement parts are manufactured to the same standards as the original parts, so you can be confident of their performance. The use of replacement parts that are not of the original design and quality may impair the effectiveness of your emission control system.

A manufacturer of an aftermarket part assumes the responsibility that the part will not adversely affect emission performance. The manufacturer or rebuilder of the part must certify that use of the part will not result in a failure of the engine to comply with emission regulations.

Maintenance

Follow the *MAINTENANCE SCHEDULE* on page 29. Remember that this schedule is based on the assumption that your machine will be used for its designed purpose. Sustained high-load or high-temperature operation, or use in dusty conditions, will require more frequent service.

TECHNICAL & CONSUMER INFORMATION

Air Index (Models certified for sale in California)

An Air Index Information label is applied to engines certified to an emission durability time period in accordance with the requirements of the California Air Resources Board.

The bar graph is intended to provide you, our customer, the ability to compare the emissions performance of available engines. The lower the Air Index, the less pollution.

The durability description is intended to provide you with information relating to the engine's emission durability period. The descriptive term indicates the useful life period for the engine's emission control system. See your *Emission Control System Warranty* for additional information.

Descriptive Term	Applicable to Emission Durability Period
Moderate	50 hours (0—80 cc, inclusive) 125 hours (greater than 80 cc)
Intermediate	125 hours (0—80 cc, inclusive) 250 hours (greater than 80 cc)
Extended	300 hours (0—80 cc, inclusive) 500 hours (greater than 80 cc) 1,000 hours (225 cc and greater)

TECHNICAL & CONSUMER INFORMATION

Specifications

Dimensions

Model	EP2500CX1	
Type	Non-California type (AH type)	California type (ACH type)
Description code	EAHC	
Length	23.5 in (597 mm)	
Width	17.1 in (435 mm)	
Height	17.2 in (437 mm)	
Dry mass (weight)	99.2 lbs (45.0 kg)	101.4 lbs (46.0 kg)

Engine

Model	GX160H1
Engine type	4-stroke, overhead valve, single cylinder
Displacement [Bore × Stroke]	9.9 cu-in (163 cm ³) [2.68 × 1.77 in (68.0 × 45.0 mm)]
Compression ratio	8.5:1
Engine speed	3,600 rpm
Cooling system	Forced air
Ignition system	Transistorized magneto ignition
Oil capacity	0.61 US qt (0.58 L)
Fuel tank capacity	3.83 US gal (14.5 L)
Spark plug	BPR6ES (NGK) W20EPR-U (DENSO)

Generator

Type	Non-California type (AH type)	California type (ACH type)
AC output	Rated voltage	120 V
	Rated frequency	60 Hz
	Rated current	19.2 A
	Rated output	2,300 VA
	Maximum output	2,500 VA

Tuneup Specifications

ITEM	SPECIFICATION	MAINTENANCE
Spark plug gap	0.028–0.031 in (0.7–0.8 mm)	Refer to page 39
Valve clearance(cold)	IN: 0.15 ± 0.02 mm EX: 0.20 ± 0.02 mm	See your authorized Honda dealer.
Other specifications	No other adjustments needed.	

Specifications may vary according to the types, and are subject to change without notice.

TECHNICAL & CONSUMER INFORMATION

Wiring Diagram

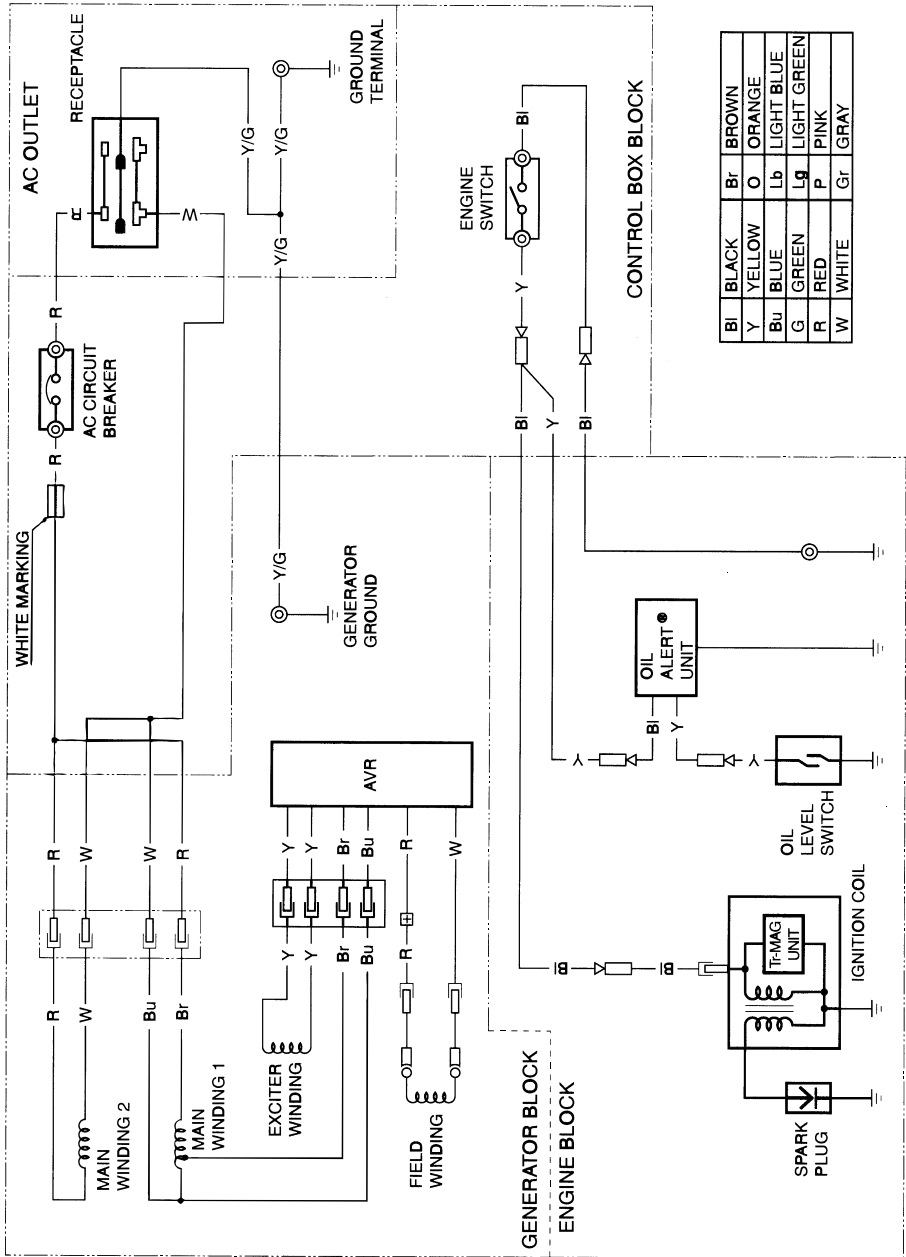

CONSUMER INFORMATION

Dealer Locator Information

To find an authorized Honda Servicing Dealer anywhere in the United States:

visit our web site:

www.hondapowerequipment.com

Honda Publications

Shop Manual

This manual covers complete maintenance and overhaul procedures. It is intended to be used by a skilled technician.

Available through your Honda dealer or through Helm Inc. at 1 (888) 292-5395 or visit www.hondapowerequipment.com

Parts Catalog

This manual provides complete, illustrated parts lists. Available through your Honda dealer.

Accessories Catalog

Your authorized Honda power equipment dealer offers a wide selection of accessories (optional equipment) to make your generator even more useful.

Visit www.hondapowerequipment.com

TECHNICAL & CONSUMER INFORMATION

Customer Service Information

Honda Power Equipment dealership personnel are trained professionals. They should be able to answer any question you may have. If you encounter a problem that your dealer does not solve to your satisfaction, please discuss it with the dealership's management. The Service Manager or General Manager can help. Almost all problems are solved in this way.

If you are dissatisfied with the decision made by the dealership's management, contact the Honda Power Equipment Customer Relations Office. You can write:

American Honda Motor Co., Inc.
Power Equipment Division
Customer Relations Office
4900 Marconi Drive
Alpharetta, Georgia 30005-8847

Or telephone: (770) 497-6400 8:30 am to 8:00 pm ET

When you write or call, please give us this information:

- Model and serial numbers (see page 52)
- Name of the dealer who sold the generator to you
- Name and address of the dealer who services your generator
- Date of purchase
- Your name, address, and telephone number
- A detailed description of the problem

INITIAL USE INSTRUCTIONS

ENGINE OIL

The generator is shipped **WITHOUT OIL** in the engine.

Place the generator on a level surface.

Remove the oil filler cap/dipstick. Add enough of the recommended oil to bring the oil level to the outer edge of the oil filler hole.

Use 4-stroke motor oil that meets or exceeds the requirements for API service category SJ or later (or equivalent).

SAE 10W-30 is recommended for general use. Other viscosities shown in the chart may be used when the average temperature in your area is within the indicated range.

Do not overfill the engine with oil. If the engine is overfilled, the excess oil may get transferred to the air cleaner housing and air filter.

Screw in the oil filler cap/dipstick securely.

FUEL

Refer to pages 30 , 31 and 43 .

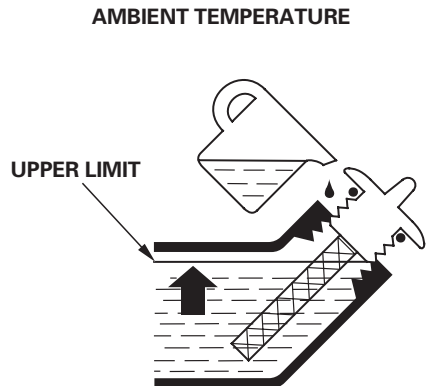
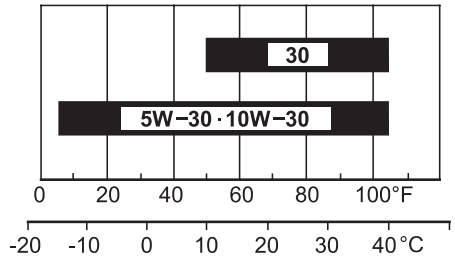
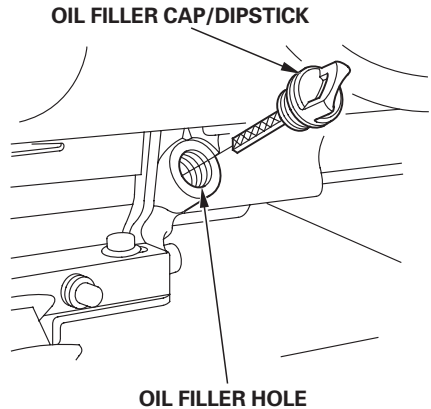

INITIAL USE INSTRUCTIONS

BEFORE OPERATION

Before using your generator, you should become familiar with information contained in the following chapters and sections:

- **GENERATOR SAFETY** (page 6)
- **CONTROLS & FEATURES** (page 10)
- **OPERATION** (page 18)
- **STARTING THE ENGINE** (page 20)
- **STOPPING THE ENGINE** (page 22)

INDEX

A	
AC Applications	24
AC Circuit Breaker	13
AC OPERATION	23
AIR CLEANER SERVICE	35
Air Index	56
ARE YOU READY TO GET STARTED?	16
B	
BEFORE OPERATION	16, 62
C	
Carbon Monoxide hazards	6
Carburetor Modification for High Altitude Operation	53
Check the Engine	17
Choke Lever	12
Cleaning	43
COMPONENT & CONTROL LOCATIONS	10
Connections to a Building's Electrical System	25
CONSUMER INFORMATION	59
CONTROLS	12
CONTROLS & FEATURES	10
Customer Service Information	60
D	
Dealer Locator Information	59
E	
Electric Shock Hazards	7
Emission Control System Information	54
ENGINE LACKS POWER	50
Engine oil	46, 61
ENGINE OIL CHANGE	33
ENGINE OIL LEVEL CHECK	32
ENGINE OIL RECOMMENDATIONS	34
Engine Switch	13
ENGINE WILL NOT START	49

INDEX

F	
FEATURES	14
Fire and Burn Hazards	7
FOAM AIR FILTER CLEANING	37
Fuel	43, 61
Fuel Gauge	15
FUEL RECOMMENDATIONS	31
Fuel Valve Lever	12
G	
GENERATOR SAFETY	6
Ground Terminal	14
H	
Honda Publications	59
I	
IMPORTANT SAFETY INFORMATION	6
INITIAL USE INSTRUCTIONS	61
IS YOUR GENERATOR READY TO GO?	16
K	
Knowledge	16
M	
MAINTENANCE SAFETY	28
MAINTENANCE SCHEDULE	29
N	
NO POWER AT THE RECEPTACLES	51

O	
Oil Alert® System	14
OPERATION	18
Operator Responsibility	6
Q	
QUICK REFERENCE INFORMATION	Inside back cover
R	
REFUELING	30
Refuel With Care	8
REMOVAL FROM STORAGE	47
S	
SAFE OPERATING PRECAUTIONS	18
SAFETY LABEL LOCATIONS	9
Safety Precautions	28
SEDIMENT CUP CLEANING	38
Serial Number Location	52
SERVICING YOUR GENERATOR	27
SPARK ARRESTER SERVICE	41
SPARK PLUG SERVICE	39
Special Requirements	26
Specifications	57
STANDBY POWER	25
Starter Grip	13
STARTING THE ENGINE	20
STOPPING THE ENGINE	22
STORAGE	43
STORAGE PRECAUTIONS	47
STORAGE PREPARATION	43
System Ground	25

INDEX

T	
TAKING CARE OF UNEXPECTED PROBLEMS	49
TECHNICAL & CONSUMER INFORMATION	52
TECHNICAL INFORMATION	52
THE IMPORTANCE OF MAINTENANCE	27
TRANSPORTING	48
W	
Wiring Diagram	58

MEMO

MEMO

QUICK REFERENCE INFORMATION

Fuel	Type	Regular unleaded gasoline with a pump octane rating of 86 or higher
Spark Plug	Type	NGK: BPR6ES DENSO: W20EPR-U
	Electrode Gap	0.028 – 0.031 in (0.7 – 0.8 mm)
Maintenance	Before each use	Check engine oil level. Check air filter.
	First 20 hours	Change engine oil.
	Subsequent	See Maintenance Schedule (page 29)

HONDA

The Power of Dreams

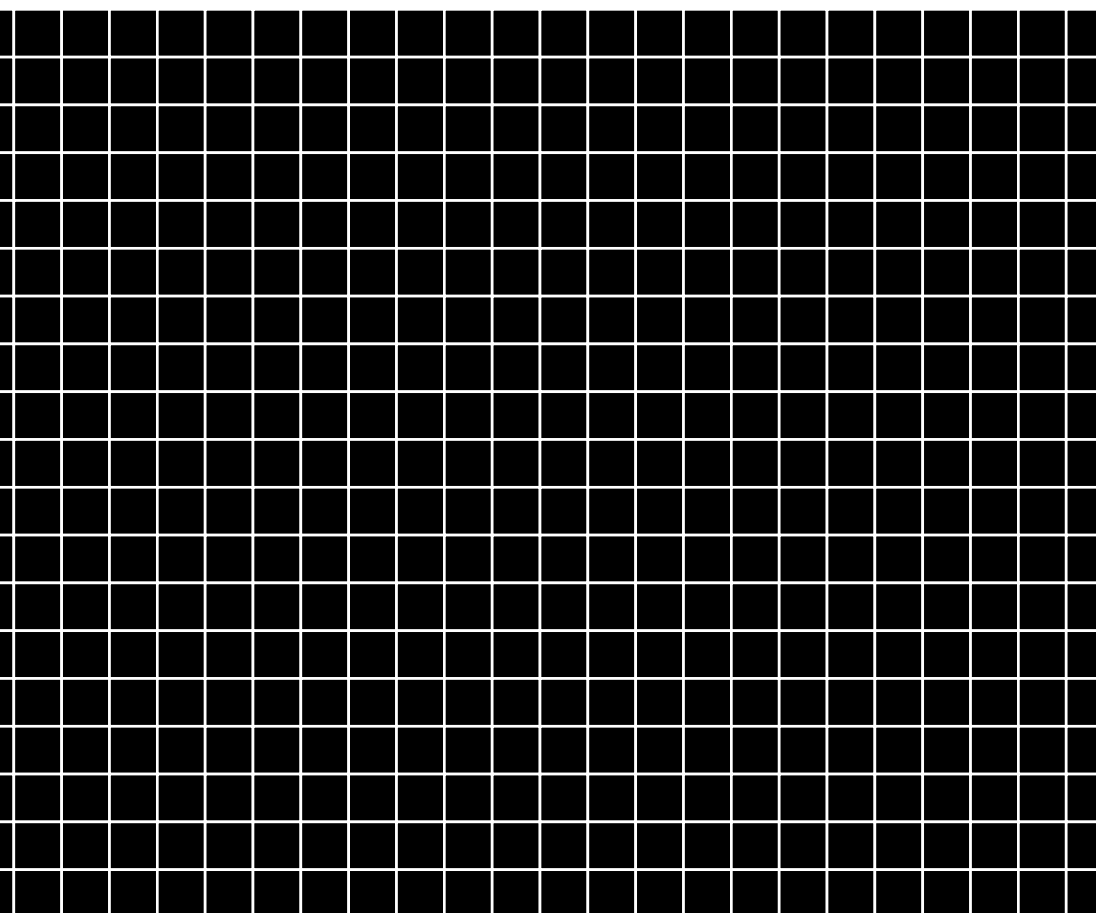

00X31Z156020

EM4

AH
Hi

英

Y

HC

2000.2007.12

Printed in Japan