

# OWNER'S MANUAL

## FG110

### MINI-TILLER



Before operating the tiller for the first time, please read this Owner's Manual. Even if you have operated other tillers, take time to become familiar with how this tiller works and practice in a safe area until you build up your skills.

## QUICK FIND

Add Fuel .....	6	Fuel System Maintenance .....	19	Spark Plug .....	11
Air Filter.....	10	How to Contact Honda.....	20	Tine Installation.....	5
Check the Engine Oil Level.....	5	Maintenance Schedule .....	10	Warranty Coverage.....	21
Dealer Locator Information .....	20	Oil Change .....	10		

## CONTENTS

WELCOME .....	2	SERVICING YOUR TILLER.....	9	TROUBLESHOOTING .....	16
FOR YOUR SAFETY .....	2	Maintenance Safety.....	9	Engine Will Not Start .....	16
PARTS AND CONTROLS .....	3	Maintenance Schedule.....	10	Loss of Power.....	16
INITIAL TILLER SETUP.....	3	Oil Change .....	10	Tiller Tines Won't Stop Turning .....	16
List of Parts .....	3	Engine Oil Recommendations.....	10	TECHNICAL INFORMATION.....	17
Adjust the Handlebar.....	4	Air Filter.....	10	Serial Number Locations .....	17
Add Engine Oil .....	4	Spark Plug.....	11	High Altitude Operation .....	17
Please Register Your Mini-Tiller.....	4	Spark Arrester (optional part).....	12	Emission Control System .....	17
Before Using Your Mini-Tiller .....	4	Cooling Fin Inspection.....	12	Air Index .....	18
BEFORE EACH OPERATION .....	4	Throttle Cable Inspection .....	12	Specifications .....	18
Check Your Tiller.....	4	Throttle Cable Adjustment.....	13	AVOIDING FUEL-RELATED PROBLEMS. ....	19
Check Your Tilling Area.....	4	Fuel Tube and Fuel Cap Inspection ..	13	CUSTOMER INFORMATION .....	20
Tine Installation .....	5	Fuel Filter and Fuel Tank Cleaning ...	13	Parts, Accessories, and Service Items ...	20
Drag Bar Installation.....	5	Transmission Lubrication .....	14	Dealer Locator Information .....	20
Moving the Tiller.....	5	TRANSPORTING .....	15	How to Contact Honda .....	20
Check the Engine Oil Level.....	5	Before Loading .....	15	Honda Publications.....	20
Add Fuel.....	6	Loading.....	15	DISTRIBUTOR'S LIMITED WARRANTY ...	21
OPERATION.....	6	STORAGE .....	15	EMISSION CONTROL SYSTEM	
Safe Tilling Practices.....	7	Fuel .....	15	WARRANTY.....	22
Attachments and Modifications .....	7	Oil.....	15	PRODUCT REGISTRATION .....	23
Starting the Engine.....	7	Cleaning .....	15		
Stopping the Engine.....	8	Storage Location .....	16		
Tiller Operation.....	8	Loading.....	16		
		Removing From Storage .....	16		

### REGISTER YOUR PRODUCT

To register your tiller, scan the QR code or see [page 23](#) for additional ways to register.



### QUESTIONS?

Contact your Honda dealer. There is a dealer locator at [powerequipment.honda.com](http://powerequipment.honda.com)

# HONDA



---

---

# WELCOME

---

---

Congratulations on your selection of a Honda FG110 mini-tiller! We are certain you will be pleased with your purchase of one of the finest tillers on the market. We want to help you get the best results from your new tiller and to operate it safely. This manual contains information on how to do that; please read it carefully.

When your tiller needs scheduled maintenance, keep in mind that Honda Power Equipment servicing dealership personnel are specially trained in servicing Honda tillers and are supported by the parts and service divisions of American Honda.

Please read the *DISTRIBUTOR'S LIMITED WARRANTY* on [page 21](#) and the *EMISSION CONTROL SYSTEM WARRANTY* on [page 22](#) to fully understand what is covered by warranty and your responsibilities of ownership.

---

---

## FOR YOUR SAFETY

---

---

Your safety and the safety of others are very important. We have provided important safety messages in this manual and on the tiller. This information alerts you to potential hazards that could hurt you or others. Please read these messages carefully.

Of course, it is not practical or possible to warn you about all the hazards associated with operating or maintaining a mini-tiller. You must use your own good judgment.

### Safety Instructions

You will find important safety information in a variety of forms:

- **Safety Labels** – on the mini-tiller.
- **Instructions** – how to use this tiller correctly and safely.
- **Safety Messages** – preceded by a safety alert  symbol and one of three signal words: DANGER, WARNING, or CAUTION. Each message tells you what the hazard is, what can happen, and what you can do to avoid or reduce injury. These signal words mean:

 **DANGER**

You **WILL** be KILLED or SERIOUSLY HURT if you don't follow instructions.

 **WARNING**

You **CAN** be KILLED or SERIOUSLY HURT if you don't follow instructions.

 **CAUTION**

You **CAN** be HURT if you don't follow instructions.

- **Damage Prevention Messages** – You will also see other important messages that are preceded by the word NOTICE. This word means:

**NOTICE**

Your tiller, other property, or the environment can be damaged if you don't follow instructions.

**WARNING:**

The engine exhaust from this product contains chemicals known to the State of California to cause cancer, birth defects, or reproductive harm.

## Important Message to Employers

As an employer, you have special responsibilities to the people who work for you. Do not allow an inexperienced, untrained operator to use this tiller without proper instruction, and always make sure the operator is an adult.

Before you ask anyone to operate this tiller, you need to determine whether the person is old enough, large enough, and strong enough to safely handle and control the tiller.

If you decide they are, make sure the employee reads and understands all instructions and warnings in this manual and on the labels before operating the tiller.

Allow adequate time for hands-on training by a qualified instructor, and personally supervise practice sessions until you feel sure the employee is ready to operate the machine.

Also be sure employees wear proper clothing and have eye protection and any other gear that may be required by local ordinances or your insurance company.

Remember, too, that you are responsible for keeping the tiller properly maintained and in safe operating condition.

Your commitment to safety on the job can help prevent injuries and result in longer and more productive years of service.

## Important Message to Parents

Never allow a child to operate the tiller.

## Safety Label Locations

These labels warn you of potential hazards that can cause serious injury. Read them carefully. If a label comes off or becomes hard to read, contact an authorized Honda servicing dealer for a replacement.

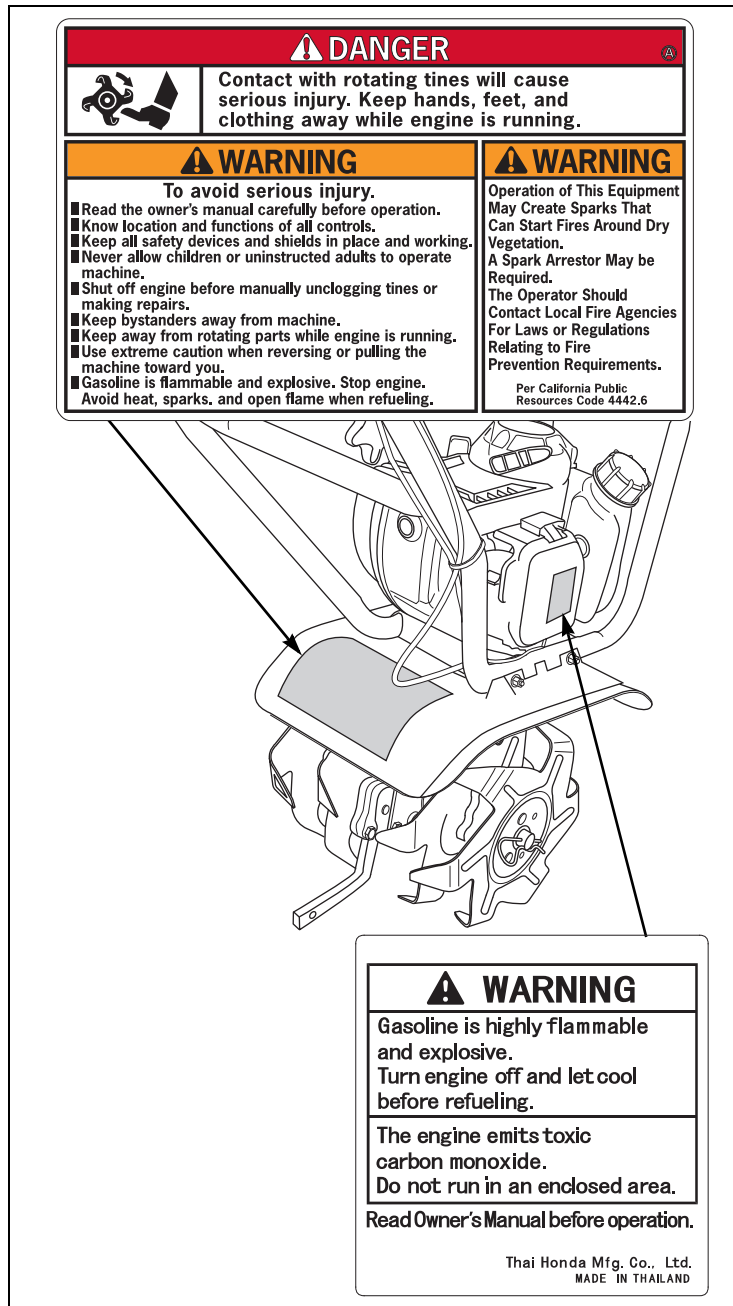

## PARTS AND CONTROLS

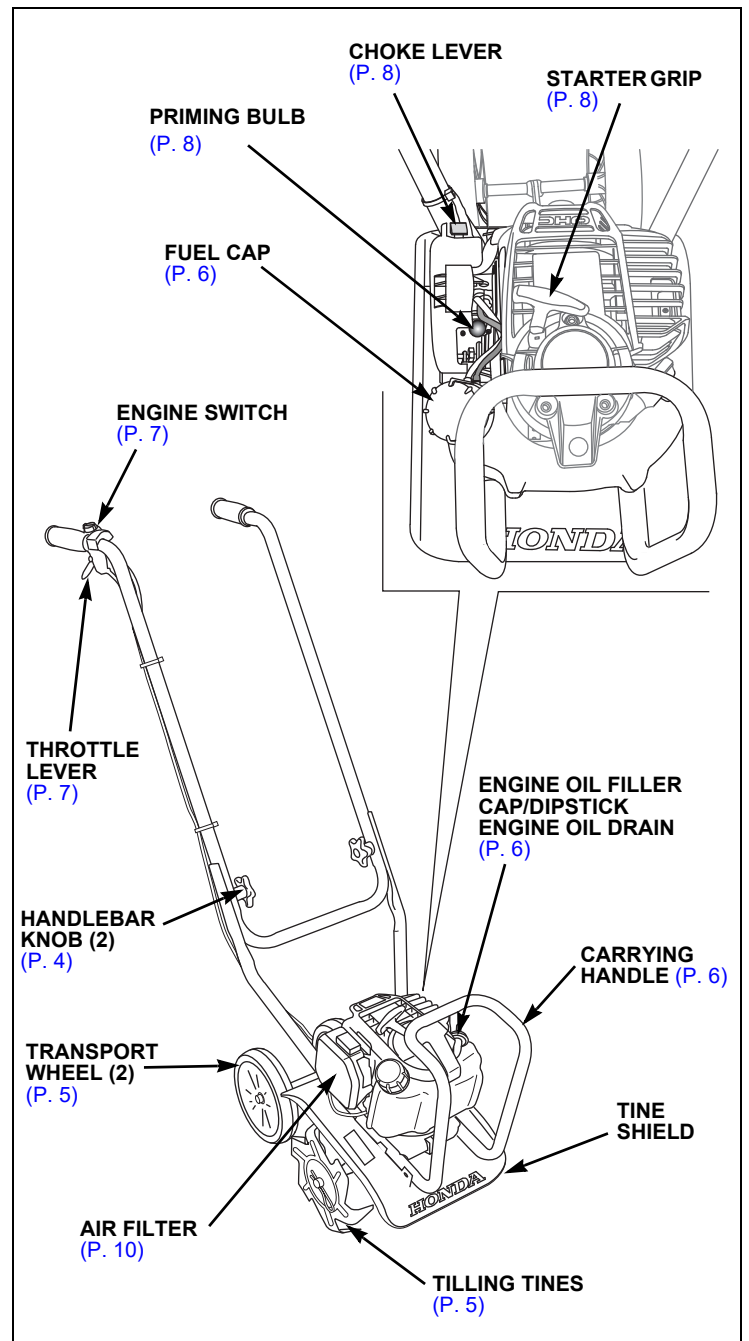

## INITIAL TILLER SETUP

### List of Parts

Carefully remove the tiller and loose parts from the carton and compare the loose parts against the following list. Contact the authorized Honda dealer from whom you purchased the tiller if any of the loose parts listed are not included with your tiller.

Description	Qty.
SAE 10W-30 engine oil, 2.7 fl. oz (80 cc)	1
Owner's manual	1



## Adjust the Handlebar

1. Carefully remove the tiller from the carton.
2. Unfold the tiller upper handle to the operating position as shown. Be careful not to crimp or pinch the engine switch wires and throttle cable.
3. Tighten the handlebar knobs to secure the handle in the upright operating position.

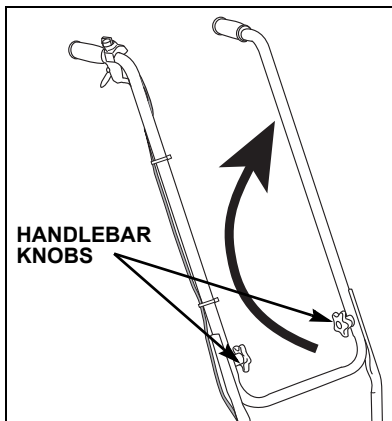

## Add Engine Oil

The tiller is shipped **WITHOUT OIL** in the engine.

Working on a level surface, tip the tiller forward on its carrying handlebar as shown.

A 2.7 fl. oz. (80 cc) bottle of oil is included in the box with your tiller. Add the entire contents of the oil bottle into the oil filler opening.

All Honda engines are run at the factory prior to packaging. Most of the oil is removed prior to shipment; however, some oil remains in the engine. The amount of oil left in the engine varies.

If not using the supplied oil, add enough recommended oil ([page 10](#)) to bring the oil level to the edge of the oil filler hole.

Do not overfill the engine with oil, as the oil tank capacity is small. See [page 10](#) for additional information.

### NOTICE

*Running the engine with too little or too much oil can cause engine damage. This type of damage is not covered by the DISTRIBUTOR'S LIMITED WARRANTY ([page 21](#)).*

Screw in the oil filler cap/dipstick securely.

## Please Register Your Mini-Tiller

Please take a few minutes and register your purchase with Honda. You can register by:

- Completing and mailing the registration card included with this owner's manual
- Scanning the QR code to the right and completing the online form
- Going online to [powerequipment.honda.com/reg](http://powerequipment.honda.com/reg)



## Before Using Your Mini-Tiller

Before using the mini-tiller, all tiller operators must read the following sections:

- **FOR YOUR SAFETY** ([page 2](#))
- **BEFORE EACH OPERATION** ([page 4](#))
- **OPERATION** ([page 6](#))
- **MAINTENANCE SCHEDULE** ([page 10](#))

## BEFORE EACH OPERATION

Your safety is your responsibility. A little time spent in preparation will significantly reduce your risk of injury.

Read and understand this manual. Know what the controls do and how to operate them.

Familiarize yourself with the tiller and its operation before you begin using it. Know how to quickly disengage the controls and shut off the engine in case of an emergency.

## Check Your Tiller

For your safety, to ensure compliance with environmental regulations, and to maximize the service life of your mini-tiller, it is very important to take a few moments before you operate the tiller to check its condition. Be sure to take care of any problem you find, or have your servicing dealer correct it, before you operate the tiller.

### ⚠ WARNING

Improperly maintaining this mini-tiller, or failing to correct a problem before operation, could cause a serious malfunction.

Some malfunctions can seriously hurt or kill you.

Always perform a pre-operation inspection before each operation, and correct any problem.

- Make sure the tiller is on a level surface.
- Look around and underneath the tiller for signs of oil or gasoline leaks.
- Look for signs of damage.
- Check each control for proper operation.
- Check the tines for wear. Replace as necessary ([page 5](#)).
- Check that all nuts, bolts, and screws are tightened.
- Check the air filter ([page 10](#)) and oil level ([page 5](#)).
- Check the fuel level ([page 6](#)). Starting with a full tank will help to eliminate or reduce operating interruptions for refueling.

## Check Your Tilling Area

For your safety and the safety of others, always inspect the area before operating the mini-tiller.

Anything that can be picked up by the tines and thrown is a potential hazard to you and others. Look for things like stones, sticks, nails, and wire, and remove them from the tilling area. If a foreign object is struck with the tiller, stop the engine, remove the spark plug cap, thoroughly inspect the tiller for any damage, and repair any damage before restarting and operating the tiller.

Never operate the tiller without good visibility or light.

People and animals near the tilling area can move into your tillers path or into a position where they could be struck by thrown objects. Clear the area of pets and people, especially children. Their safety is your responsibility. Stay alert for hidden hazards or traffic. Exercise extreme caution when crossing gravel surfaces.

Check the condition of the ground. Adjust your tiller's drag bar accordingly.

## Tine Installation

Make sure the tines are installed properly with the tine blades angled inward and the tine spacers facing each other. The leading edge of each blade is slanted. Install the lock pin in the direction shown.

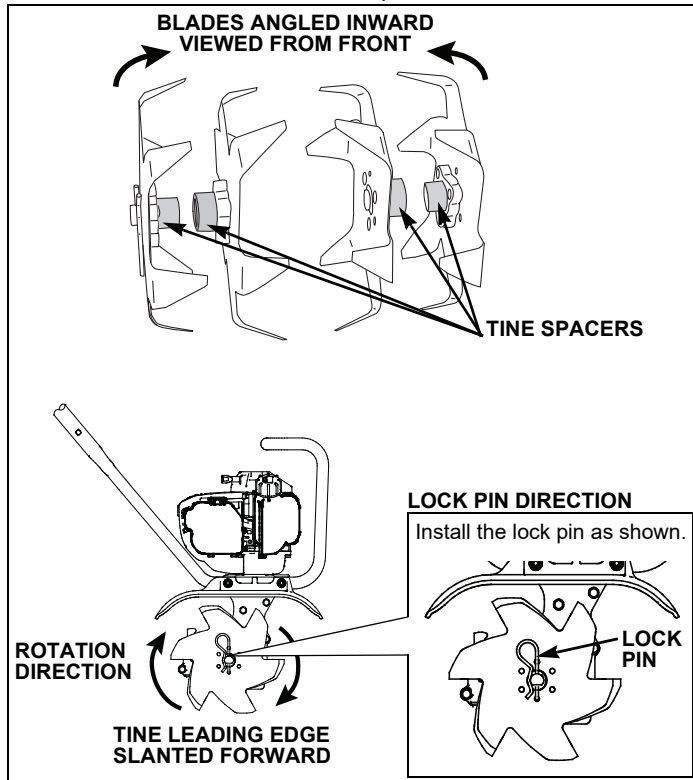

## Drag Bar Installation

1. Make sure the engine switch is in the OFF position before installing the drag bar.
2. Remove the lock pin and the 6 x 25 mm clevis pin.
3. Install the drag bar angled to the rear. Adjust the height to one of 4 height positions and insert the 6 x 25 mm clevis pin. Secure with the lock pin.

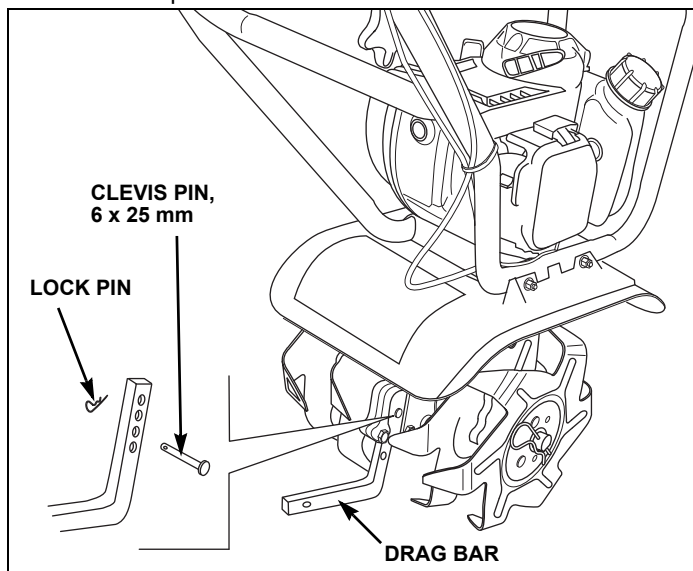

See "Tiller Operation" on [page 8](#) for additional information.

When your tilling job is completed, reinstall the transport wheels onto the drag bar.

## Moving the Tiller

The tiller has wheels to allow easy maneuvering to and from the work area.

Do not transport the tiller with the engine running. Never operate the tiller at high transport speeds on hard or slippery surfaces.

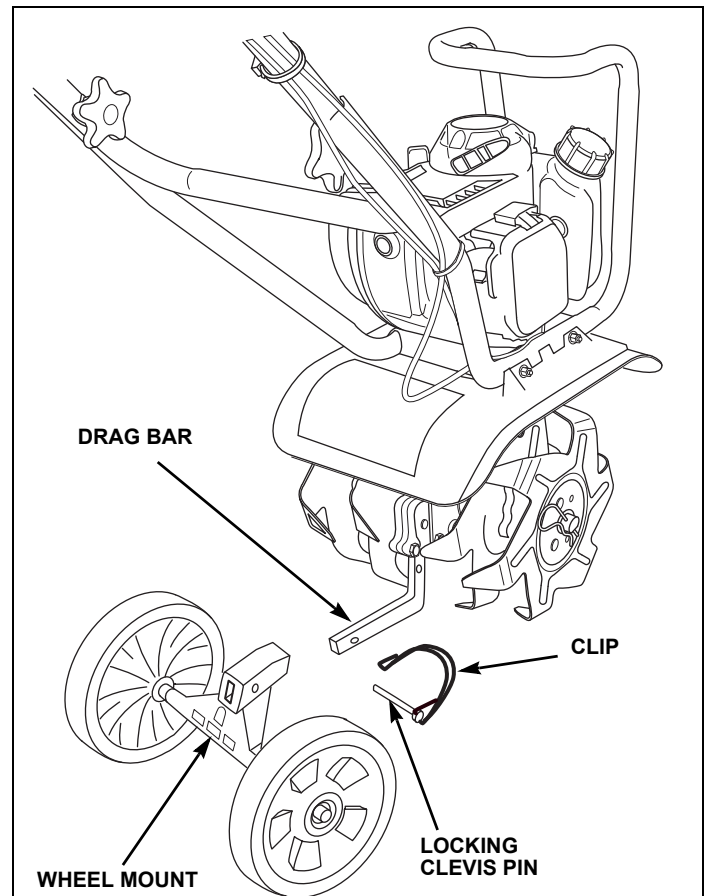

1. Install the wheels by inserting the wheel mount onto the drag bar. Secure with the locking clevis pin.

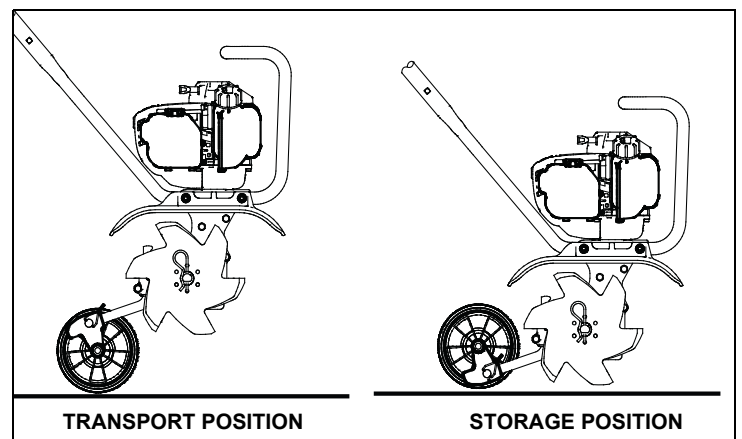

2. Before tilling, remove the wheels from the drag bar.

## Check the Engine Oil Level

Check the engine oil level before each use, or every 10 hours if operated continuously. Rest the tiller on a level surface with the engine stopped.

1. Tip the tiller on its carry handlebar as shown.
2. Remove any dirt from around the cap/dipstick area.

- Remove the oil filler cap/dipstick and wipe it clean.

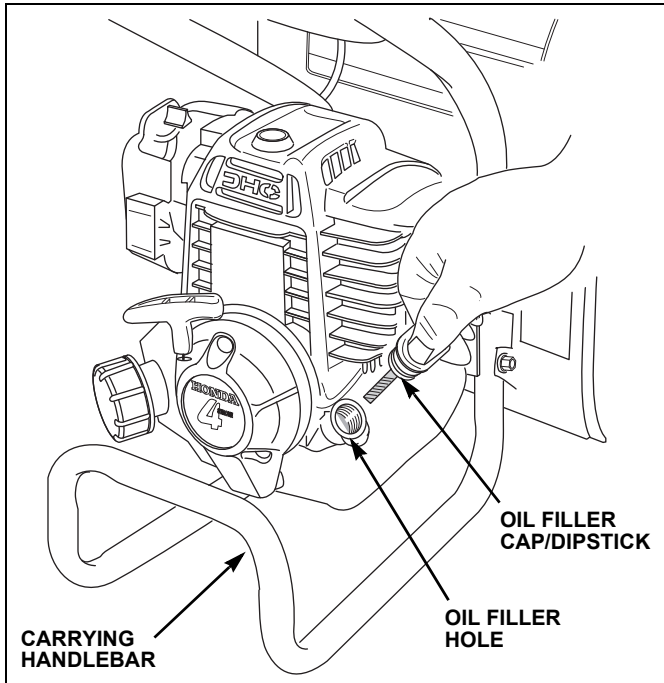

- Insert and remove the dipstick **without screwing it into the filler opening**. Check the oil level shown on the dipstick.
- If the oil level is low, fill to the edge of the oil filler hole with the recommended oil. Avoid overfilling or underfilling, as the oil capacity is small. Be sure the engine is in a level position, as shown.

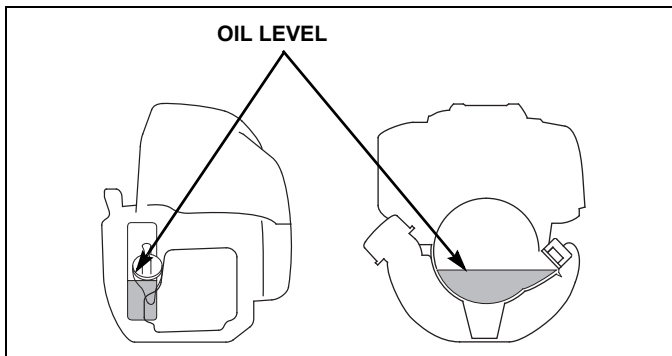

**NOTICE**

Running the engine with a low oil level can cause engine damage. This type of damage is not covered by the DISTRIBUTOR'S LIMITED WARRANTY (page 21).

- Screw in the oil filler cap/dipstick securely.

## Add Fuel

This engine is certified to operate on regular gasoline with a pump octane rating of 86 or higher.

Never use stale or contaminated gasoline or an oil/gasoline mixture. Avoid getting dirt or water in the fuel tank.

You may use regular unleaded gasoline containing no more than 10% ethanol (E10) or 5% methanol by volume. In addition, methanol must contain cosolvents and corrosion inhibitors.

Use of fuels with content of ethanol or methanol greater than shown above may cause starting and/or performance problems. It may also damage metal, rubber, and plastic parts of the fuel system.

Engine damage or performance problems that result from using a fuel with percentages of ethanol or methanol greater than shown are not covered under warranty.

## ⚠ WARNING

Gasoline is highly flammable and explosive.

You can be burned or seriously injured when refueling.

- Stop the engine and let it cool before refueling
- Keep heat, sparks, and flame away
- Refuel only outdoors
- Wipe up spills immediately

**NOTICE**

If your equipment will be used on an infrequent or intermittent basis, (more than 4 weeks before next use), refer to "AVOIDING FUEL-RELATED PROBLEMS" on page 19 for information regarding fuel deterioration.

- To refuel, set the tiller on level ground and remove the fuel tank cap.
- Fill the tank with gasoline to the shoulder of the filler neck.
- Refuel carefully to avoid spilling fuel. Do not overfill.
- After refueling, tighten the fuel tank cap securely.

Move the tiller at least 3 meters (10 feet) away from the fueling source and site before starting the engine.

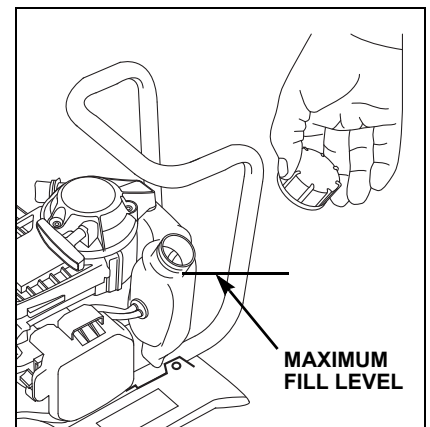

**NOTICE**

Fuel can damage paint and plastic. Be careful not to spill fuel when filling your fuel tank. Damage caused by spilled fuel is not covered by the DISTRIBUTOR'S LIMITED WARRANTY (page 21).

## OPERATION

For your safety, avoid starting or operating the engine in an enclosed area, such as a garage. Your tillers exhaust contains poisonous carbon monoxide gas, which can collect rapidly in an enclosed area and cause illness or death.

## ⚠ WARNING

Exhaust contains poisonous carbon monoxide gas that can build up to dangerous levels in closed areas.

Breathing carbon monoxide can cause unconsciousness or death.

Never run the mini-tiller in a closed, or even partially closed area where people may be present.

Do not overload the tiller by attempting to till or cultivate too deep at too fast a rate. Be careful when tilling in hard ground. The tines may catch in the ground and propel the tiller forward. If this occurs, let go of the handlebars and do not restrain the machine. Use extreme caution when reversing or pulling the tiller toward you. To avoid getting pinned against a structure, ensure adequate distance before backing up near a wall or fence.

If the tiller starts to shake or vibrate, stop the engine immediately. After the tiller tines have completely stopped, inspect them to determine the cause of the vibration. Sudden vibration is a sign of a hazardous problem, such as a loose or damaged tilling tines (or tiller attachment), hidden objects in the soil, or the ground that is too hard to till. Do not operate the tiller until the problem is corrected.

Prolonged exposure to vibration may cause Hand-Arm Vibration Syndrome (HAVS). Symptoms include loss of skin color in the hands and numbness or a painful tingling sensation in the fingers, hands, and arms. Regular users of any power equipment may feel the numbness or pain spontaneously, at any time, not just after using the equipment. If any of these symptoms occur, see a physician immediately.

## Safe Tilling Practices

Honda tillers are designed to give safe and dependable service if operated according to instructions and intended use.

Honda tillers are intended to be used by an experienced, trained operator who is familiar with the use of power equipment. Never allow a child to operate this tiller. Do not allow an inexperienced, untrained adult operator to use this tiller without proper instruction. Operating this equipment requires special effort on your part to ensure your safety and the safety of others. Read and understand this owner's manual.

Powered walk-behind tiller work is strenuous. You must be mentally alert and in good physical condition to operate the tiller. Do not operate the tiller if you are tired, ill, or under the influence of alcohol, medication, or any substance that might impair your vision, dexterity, or judgment.

If you have any physical problem that may be aggravated by strenuous work, consult your physician before operating the tiller.

## Avoid Rotating Tines

The rotating tines can cause injury. Do not allow hands, feet, other body parts, or clothing near the rotating tines or any other moving part. Keep away from the tine shield whenever the engine is running. If you need to unclog or adjust the tines, or work around the tines for any reason, always stop the engine. Never attempt to make any adjustments while the engine is running. If you need to clean or handle the tines, disconnect the spark plug cap and keep the cap away from the plug to prevent accidental starting.

## Clear Tilling Area

The tiller tines can throw rocks and other objects with enough force to cause injury. Before tilling, carefully inspect the area and remove all large debris.

## Keep Shields in Place

Guards and shields are designed to protect you from being hit by thrown objects. They also help protect you from hot engine parts and moving components. For your safety and the safety of others, keep all guards and shields in place when operating the tiller.

## Refuel with Care

To avoid personal injury or property damage, use extreme care in handling gasoline. Gasoline is extremely flammable and gasoline vapor can explode. Refuel only outdoors, in a well-ventilated area, with the engine off.

Never fill gasoline containers inside a vehicle or on a truck bed with a plastic liner. Always place gasoline containers on the ground away from your vehicle before filling. Remove the tiller from the truck or trailer and refuel it on the ground. If this is not possible, then refuel the tiller with a portable gasoline container, rather than the gasoline dispenser nozzle. Keep the nozzle in contact with the rim of the fuel tank or container opening at all times until fueling is complete, and do not use a nozzle lock-open device.

If gasoline is spilled on your clothing, change your clothing immediately. If gasoline is spilled, do not attempt to start the engine until you move the tiller away from the area of spillage to avoid creating any source of ignition until the gasoline vapors have dissipated.

Never smoke near gasoline, and keep other flames and sparks away. When the engine is running, never remove the gas cap or add gasoline. Always store gasoline in an approved container.

## Wear Protective Clothing

Wearing protective clothing will reduce your risk of injury. Long pants and eye protection reduce the risk of injuries from thrown objects. Wear gloves at all times to protect your hands from injury. Sturdy shoes with aggressive soles will help protect your feet and give you better traction on slopes or uneven ground. Exercise caution to avoid slipping and falling. Do not operate the tiller wearing short pants (shorts) or open-toed shoes. Clothing worn by the operator should be close-fitting. Loose clothing should not be permitted because it may get caught in moving parts. Tie up or restrain long hair.

## Turn Engine Off When Not Tilling

Stop the engine when leaving the tiller unattended. If you need to leave the tiller for any reason, even just to inspect the area ahead, always stop the engine.

## Attachments and Modifications

Do not make any modifications to your tiller. Modifying your tiller or installing non-Honda attachments can make your tiller unsafe.

If you need attachments for your tiller, use only Honda Genuine attachments (see [page 20](#)). These products have been designed for your tiller.

Non-Honda attachments are usually designed for universal applications. Although aftermarket attachments may fit on your tiller, they may not meet factory specifications and could make your tiller unsafe.

## Starting the Engine

1. Disengage the throttle (clutch) lever before starting the engine.
2. Move the engine switch to the ON position.
3. To start a cold engine, move the choke lever up to the CLOSED (N) position.

To restart a warm engine, leave the choke lever down in the OPEN position.

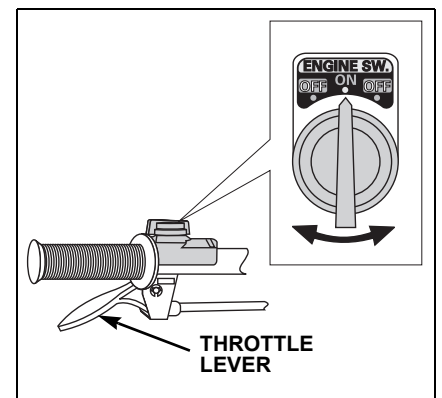



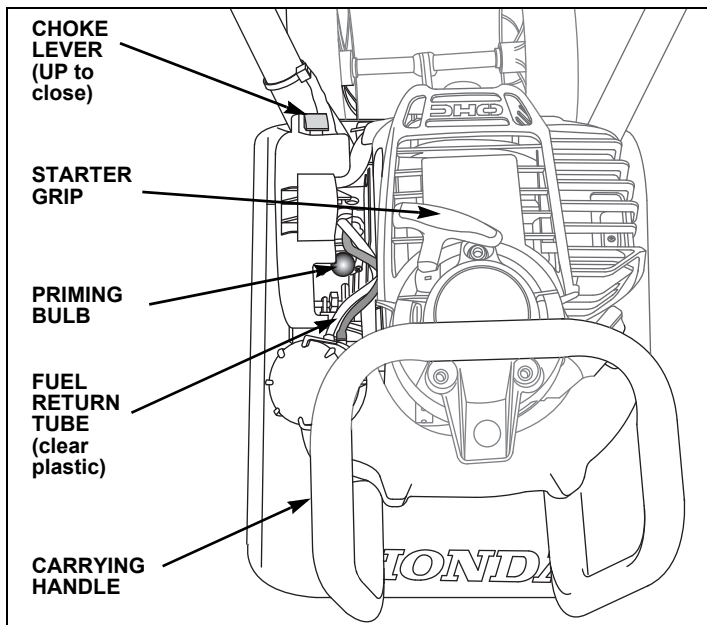

4. To start a cold engine, or after refueling an engine that has run out of fuel, press the priming bulb repeatedly until fuel can be seen in the clear-plastic fuel-return tube.  
To restart a warm engine, it is not necessary to press the priming bulb.
5. Place your left hand on the carrying handle and hold it firmly. Make sure your feet are away from the tiller tines. With your right hand, pull the starter grip lightly until you feel resistance, then pull briskly. Return the starter grip gently.
6. If the choke lever was moved to the CLOSED (N) position, gradually move it to the OPEN position as the engine warms up.

Allow the engine to warm up for a few moments after starting a cold engine.

The tiller tines should not rotate with the engine idling. If there is rotation at idle, adjust the idle speed correctly before using the tiller ([page 13](#)).

## Stopping the Engine

1. Release the throttle lever.
2. Move the engine switch to the OFF position.

See "STORAGE" on [page 15](#) for periods of inactivity that exceed 4 weeks.

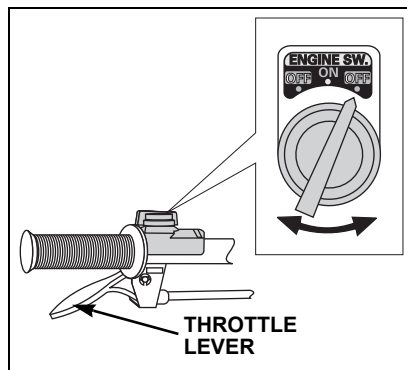

## Tiller Operation

### Before tilling, remove the wheels from the drag bar

The tiller tines begin to rotate once the engine is started and the throttle lever is squeezed. The tines may momentarily rotate after the throttle lever is released. Stop the engine when leaving the tiller unattended.

The tiller is designed to operate either with the drag bar installed for depth control in the forward direction or with the drag bar removed for cultivating.

### Cultivating Without the Drag Bar

Cultivating can be accomplished by removing the drag bar and repeatedly moving the tiller in a forward/reverse direction. This allows the tines to dig in both directions.

Be aware that the tiller can be difficult to control without the drag bar installed.

### Narrow Cultivating

The two outer tines can be removed to give you a narrower cultivating width. This width is approximately 5 inches. This gives you the ability to get between very closely spaced plants.

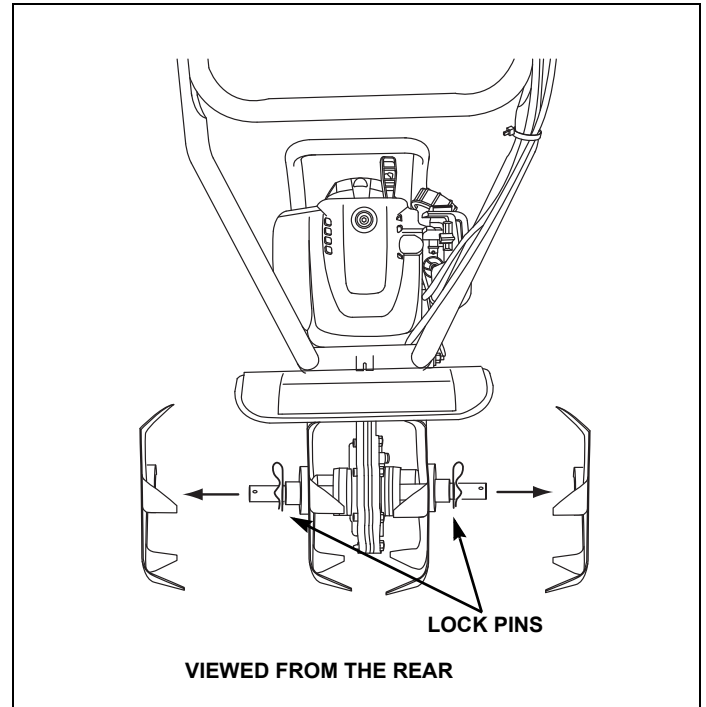

To remove the two outer tines, pull the lock pin out of the hole in the end of the tine shaft. Slide the outside tine set off the tine shaft. Secure the inner set of tines onto the tine shaft by placing the lock pins in the inside set of lock pin holes.

### Tilling With the Drag Bar Installed

1. Install the drag bar and set the tilling depth by moving the drag bar up or down into one of 4 height positions ([page 5](#)).

The ideal height of the drag bar will depend on the type of soil being tilled and soil conditions at the time of tilling. In general, however, the drag bar should be adjusted so that the tiller is tilted slightly backward (6 ~ 8°).

2. Start the engine ([page 7](#)).
3. Tilt the tiller back until the tines are off the ground. Squeeze the throttle lever to full speed position (lever tight against the grip).
4. Lower the front of the tiller until the tines begin to dig into the ground.

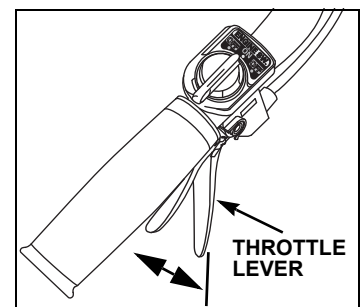



- Lower the handle slightly so the front of the tiller is raised about 6 ~ 8°. To get the maximum advantage from the tiller, hold the tiller at this angle while you are tilling the ground.

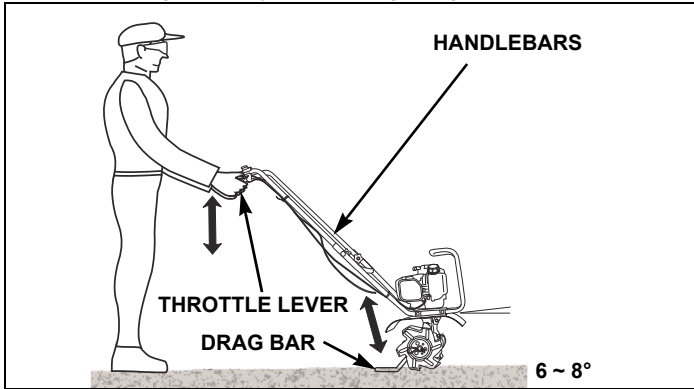

### Operating Tips

- If the tiller tends to move forward rapidly, push down on the handlebars to allow the drag bar to penetrate the soil and slow the forward motion of the tiller. Continue to press down until the tiller tines have dug to a desired depth that allows easy tiller handling.
- If the tines dig in but the tiller will not move forward, ease up on the handlebars and move the handlebars from side-to-side. If the tiller still digs in, but will not move forward, raise the drag bar up one hole.
- When turning, push down on the handlebars to bring the tiller's weight to the rear; this will make turning easier.

## SERVICING YOUR TILLER

Proper maintenance is essential for safe, economical, and trouble-free operation. It also helps reduce air pollution. Keep the tiller, attachments, and accessories in safe working condition.

### ⚠ WARNING

Improper maintenance, or failure to correct a problem before operation, can cause a serious malfunction in which you can be seriously hurt or killed.

Some malfunctions can seriously hurt or kill you.

Always follow the inspection and maintenance recommendations and schedules in this owner's manual.

To help you properly care for your tiller, the following pages include a maintenance schedule, routine inspection procedures, and simple maintenance procedures using basic hand tools. Other service tasks that are more difficult, or require special tools, are best handled by professionals and are normally performed by a Honda technician or other qualified mechanic.

The maintenance schedule applies to normal operating conditions. If you operate your tiller under severe conditions, such as sustained high-load or high-temperature operation, or use in unusually wet or dusty conditions, consult your servicing dealer for recommendations applicable to your individual needs and use.

Remember that an authorized Honda servicing dealer knows your tiller best and is fully equipped to maintain and repair it.

To ensure the best quality and reliability, use only new, Honda Genuine parts or their equivalents for repair and replacement.

**Maintenance, replacement, or repair of the emission control devices and systems may be performed by any engine repair establishment or individual, using parts that are "certified" to EPA standards.**

## Maintenance Safety

Some of the most important safety precautions follow. However, we cannot warn you of every conceivable hazard that can arise in performing maintenance. Only you can decide whether or not you should perform a given task.

### ⚠ WARNING

Improper maintenance can cause an unsafe condition.

Failure to properly follow maintenance instructions and precautions can cause you to be seriously hurt or killed.

Always follow the procedures and precautions in this manual.

### Safety Precautions

- Make sure the engine is off and all moving parts have stopped before you begin any cleaning, maintenance, adjustments, inspections, or repairs. This will eliminate several potential hazards:
  - Carbon monoxide poisoning from engine exhaust.**  
Be sure there is adequate ventilation whenever you operate the engine.
  - Burns from hot parts.**  
Let the engine and exhaust system cool before touching.
  - Injury from moving parts.**  
Do not run the engine unless instructed to do so.
- Read the instructions before you begin, and make sure you have the tools and skills required.
- To reduce the possibility of fire or explosion, be careful when working around gasoline. Use only a nonflammable solvent, not gasoline, to clean parts. Keep cigarettes, sparks, and flames away from all fuel-related parts.

# Maintenance Schedule

Interval <sup>1</sup>	Item
Before each use	Engine oil level: Check (page 5) Air filter: Check (page 10) Throttle cable: Check (page 12) Nuts and bolts: Check for tightness
First month or 10 hours	Engine oil: Change (page 10)
Every month or 25 hours	Air filter: Clean and apply oil <sup>2</sup> (page 11)
Every 3 months or 25 hours	Transmission grease: Check (page 14)
Every 6 months or 50 hours	Engine oil: Change <sup>2</sup> (page 10) Cooling fins: Check (page 12) Clutch shoes: Check <sup>3</sup>
Every year or 100 hours	Spark plug: Check (page 11) Spark arrester: Clean (optional part) (page 12) Fuel tank and filter: Clean-check (page 13)
Every 2 years or after each 300 hours	Spark plug: Replace (page 11) Valve clearance: Check-adjust <sup>3</sup> Idle speed: Check-adjust <sup>3</sup> (page 13) Fuel tubes and primer bulb: Check (page 13) Fuel cap: Check (page 13)

1. For professional commercial use, log hours of operation to determine proper maintenance intervals.
2. Service more frequently when used in dusty areas.
3. These items should be serviced by an authorized Honda servicing dealer, unless you have the proper tools and are mechanically proficient.

Failure to follow this maintenance schedule could result in non-warrantable failure.

## Oil Change

Change the oil after the first 10 hours of use. Thereafter, change the oil every 6 months or 50 hours of use. Change the oil more often when used in dusty areas.

Drain the used oil while the engine is warm. Warm oil drains quickly and completely.

1. Place a suitable container below the engine to catch the used oil.
2. Clean dirt from around the oil filler cap/dipstick.
3. Remove the oil filler cap/dipstick.
4. Tip the tiller to drain the used oil through the oil filler opening. Allow the used oil to drain completely.

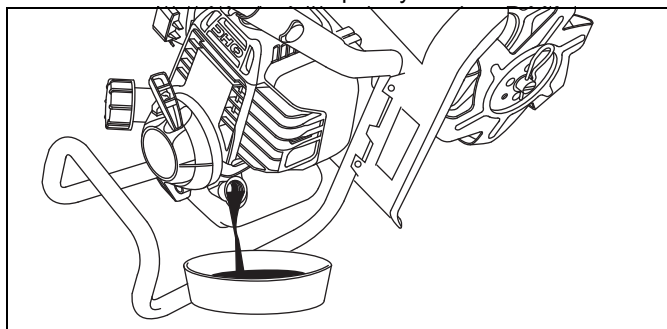

Please dispose of used motor oil in a manner that is compatible with the environment. We suggest you take used oil in a sealed container to your local recycling center or service station for reclamation. Do not throw it in the trash, pour it on the ground, or pour it down a drain.

5. With the engine resting on the carrying handlebar on a level surface, fill with the recommended oil to the edge of the oil filler hole. Do not overfill.

**Refill amount: 2.7 fl. oz (80 cc)**

6. Screw in the filler cap/dipstick securely.

## Engine Oil Recommendations

Oil is a major factor affecting performance and service life. Always change the oil in accordance with the *MAINTENANCE SCHEDULE* (page 10).

SAE 10W-30 is recommended for general use. Other viscosities shown in the chart may be used when the average temperature in your area is within the recommended range.

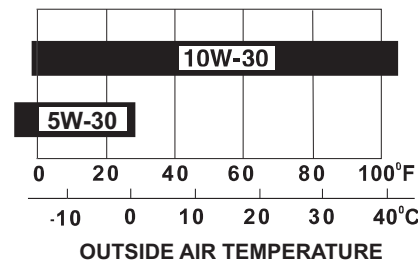

The SAE oil viscosity and service category are in the API label on the oil container. Honda recommends that you use API service category SJ or later oil.



### NOTICE

*Using nondetergent oil can shorten the engine's service life, and using 2-stroke oil can damage the engine.*

## Air Filter

Check the air filter after each use. Thereafter, clean the filter every 25 hours of use. Clean the filter more often when used in dusty areas. Replace the filter every 2 years or 150 hours of use.

A properly maintained air filter will help prevent dirt from entering your engine. Dirt entering the carburetor can be drawn into small passages in the carburetor and cause premature engine wear. These small passages can become blocked, causing starting or running problems.

We recommend the use of a Honda Genuine air filter to ensure it seals and performs as designed. Using a non-Honda air filter can result in dirt bypassing the filter, causing damage to the engine or fuel system.

### NOTICE

*Operating the engine without an air filter, or with a dry or damaged air filter, or with an improperly installed air filter cover will allow dirt to enter the engine causing rapid engine wear. Make sure the air filter is properly installed and flush with the air filter base before installing the air filter cover. This type of damage is not covered by the DISTRIBUTOR'S LIMITED WARRANTY (page 21).*

## Inspection

1. Move the choke lever to the CLOSED (N) position to prevent dirt from entering the engine.

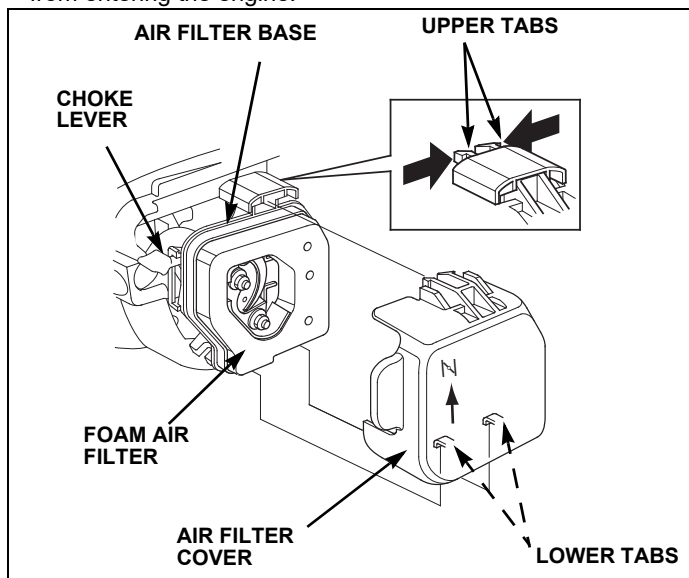

2. Squeeze together the upper tabs at the top of the air filter cover to release it from its catch, then flip the cover down to remove it.
3. Check the foam air filter to be sure it is clean, properly oiled, and in good condition.
4. If the filter is dirty, clean it as described under "Cleaning" on page 11. Replace the air filter element if it is damaged.
5. Align the air filter with the air filter base as shown. Reinstall the air filter by locating the three base pegs into the three air filter holes. Slide the air filter over the pegs until it is flush with the air filter base.

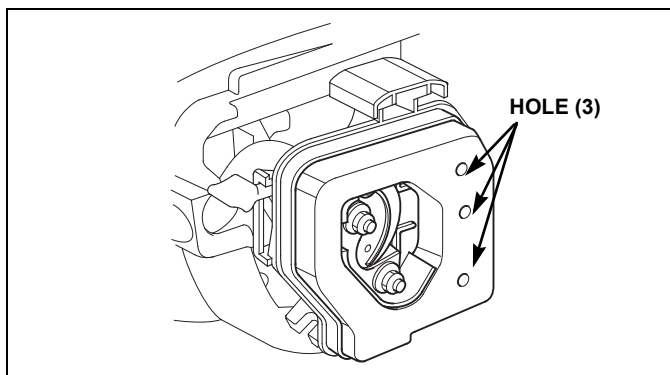

6. Reinstall the air filter cover by hooking the two lower tabs on the bottom of the cover and snapping the upper tabs into place.

## Cleaning

A dirty air filter will restrict air flow to the carburetor, reducing engine performance. If you operate the tiller in very dusty areas, clean the air filter more often than specified in the *MAINTENANCE SCHEDULE* (page 10).

We recommend using Honda Air Filter Oil, which is available from your authorized Honda dealer (page 20).

1. Remove the foam air filter from the air filter base.
2. Clean the filter in warm soapy water and rinse, or clean with nonflammable solvent.
3. Squeeze excess water from the filter and allow it to dry thoroughly.
4. Place the filter in a resealable plastic bag and pour about 1 oz. (1/4 of a bottle) of Honda Air Filter Oil into the bag. Seal the bag closed and knead the bag for one minute or longer until the oil is completely distributed into the foam filter. Squeeze excess oil from the filter.
5. Remove the filter from the bag.  
We recommend using latex gloves when removing the oiled foam air filter from the bag.

### NOTICE

*Operating the engine with a dry air filter will allow dust to enter the engine causing engine damage. The air filter must be oiled after cleaning.*

6. Wipe dirt from the air filter base and cover using a moist rag. Be careful to prevent dirt from entering the carburetor.
7. Reinstall the foam air filter and air filter cover.

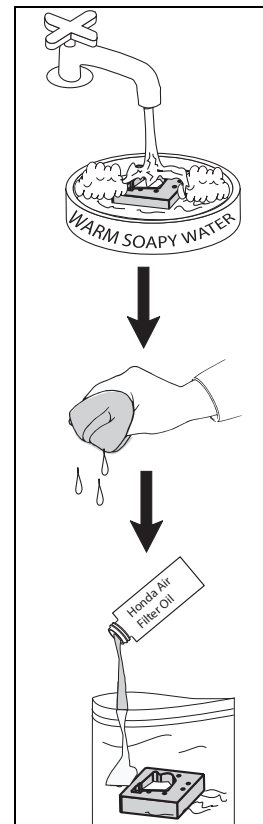

## Spark Plug

Check the spark plug every year or 100 hours of use. Replace the spark plug every 2 years or after 300 hours of use.

**Required Spark Plug:** NGK - CMR5H

### NOTICE

*An incorrect spark plug can cause engine damage.*

1. Use a 4 mm Allen wrench to loosen the 5 x 12 mm hex bolt and remove the fan cover.

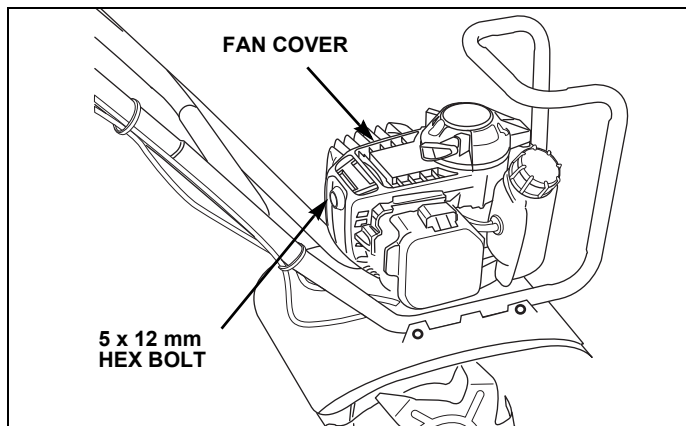

2. Disconnect the spark plug cap, and remove any dirt from around the spark plug area.
3. Remove the spark plug with a 5/8-inch spark plug wrench.

4. Inspect the spark plug. Replace it if the electrodes are worn, or if the insulator is cracked or chipped.
5. Measure the spark plug electrode gap with a suitable gauge.

**GAP: 0.024 ~ 0.028 in  
(0.60 ~ 0.70 mm)**

Correct the gap, if necessary, by carefully bending the side electrode.

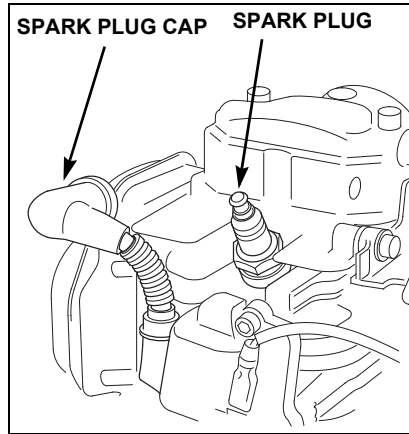

6. Install the spark plug carefully, by hand, to avoid cross-threading.
7. After the spark plug seats, tighten with a 5/8-inch spark plug wrench to compress the washer.

If reinstalling the used spark plug, tighten 1/8 ~ 1/4 turn after the spark plug seats.

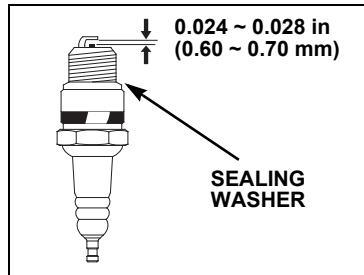

If installing a new spark plug, tighten 1/2 turn after the spark plug seats.

**Spark Plug Torque: 11.8 N•m (8.7 ft-lb)**

#### NOTICE

*A loose spark plug can overheat and damage the engine. Overtightening the spark plug can damage the threads in the cylinder head.*

8. Attach the spark plug cap.
9. Install the fan cover and 5 x 12 mm hex bolt and tighten securely.

## Spark Arrester (optional part)

The spark arrester must be serviced every 100 hours to keep it functioning as designed.

Your tiller engine is not factory-equipped with a spark arrester. In some areas, it is illegal to operate an engine without a spark arrester. Check local laws and regulations. An optional USDA approved spark arrester is available from an authorized Honda servicing dealer. See [page 20](#) for part numbers.

If the engine has been running, the muffler will be very hot. Allow the muffler to cool before servicing the spark arrester.

1. Loosen the 5 mm hex bolt, and then remove the fan cover.

2. Remove the 3 x 6 mm self-tapping screw from the spark arrester, and remove the spark arrester from the muffler.

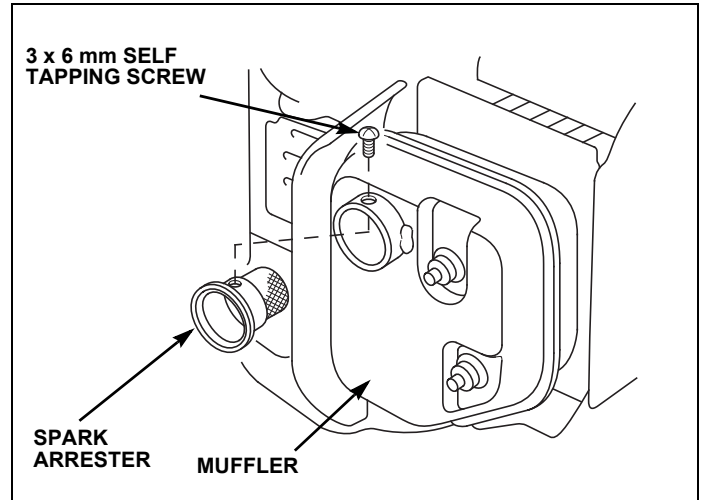

3. Use a brush to remove carbon deposits from the spark arrester screen. Be careful to avoid damaging the screen.
4. The spark arrester must be free of breaks and holes. Replace the spark arrester if it is damaged.

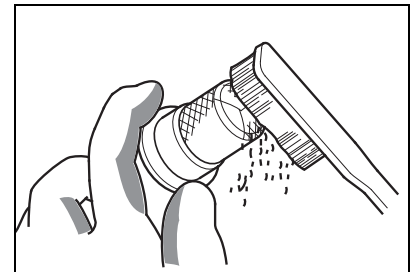

5. Install the spark arrester in the reverse order of disassembly.
6. Install the fan cover, and tighten the 5 mm hex bolt securely.

## Cooling Fin Inspection

Inspect the engine cooling fins every 50 hours of operation. You should clean out any dirt and debris if air is obstructed from flowing across the cooling fins.

1. Loosen the 5 mm hex bolt, then remove the fan cover.
2. Remove all dirt and debris from the cooling fins.
3. Install the fan cover, and tighten the 5 mm hex bolt securely.

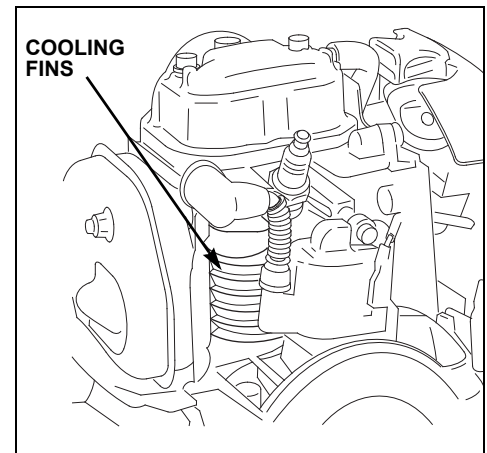

## Throttle Cable Inspection

Verify the throttle trigger operates smoothly, releases properly, and the throttle cable is undamaged. If there is visible damage, or if the throttle lever does not operate smoothly or release properly, take your tiller to your authorized Honda servicing dealer.

Check the freeplay at the end of the throttle lever.

If adjustment is needed, see the *Throttle Cable Adjustment* procedure on this page.

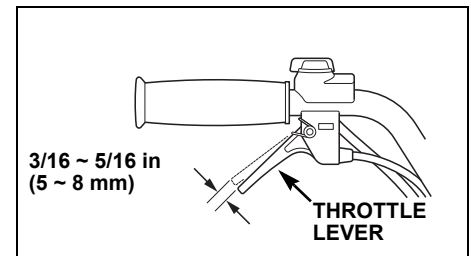



## Throttle Cable Adjustment

1. Loosen the lock nuts with a 10 mm wrench, and move the adjuster in or out as required.

**Throttle Lever Freeplay:**  
3/16 ~ 5/16 in (5 ~ 8 mm)

2. Tighten the lock nuts and recheck throttle lever freeplay.

## Carburetor Adjustment

A tachometer is required to adjust the idle speed. If you do not have one, take your tiller to an authorized Honda servicing dealer to perform idle speed adjustment.

1. Start the engine outdoors, and allow it to warm up to normal operating temperature.
2. Turn the throttle stop screw to obtain a stable idle, below the speed at which the tiller tines begin to turn.

**Standard Idle Speed: 3,100 ± 200 rpm**

## Fuel Tube and Fuel Cap Inspection

Check the fuel supply, return tubes, priming bulb, and fuel cap. Replace any tube or the priming bulb if damaged, stiff, cracked, or leaking.

Inspect the fuel cap for damage.

1. Tilt the tiller forward and check for leaks.
2. Replace if necessary.

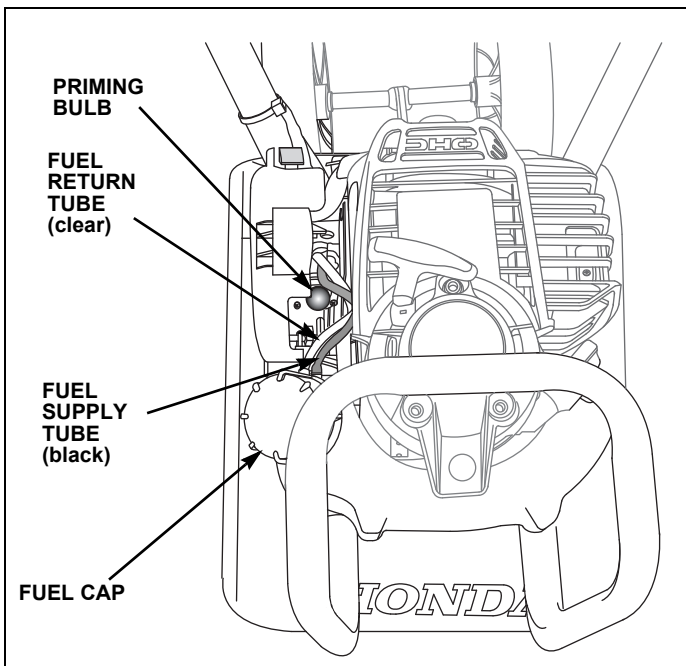

Refer to the Honda shop manual for tube or priming bulb replacement instructions, or take the tiller to an authorized Honda servicing dealer.

## Fuel Filter and Fuel Tank Cleaning

1. Remove the fuel tank cap.
2. Tip the tiller and empty the fuel tank into an approved gasoline container. Use a funnel to avoid spilling gasoline.
3. Pull the fuel filter out through the fuel filler neck by hooking the black fuel supply tube with a piece of wire, such as a partly straightened paper clip.
4. Inspect the fuel filter. If the fuel filter is dirty, wash it with nonflammable solvent. Be careful to avoid damaging the filter.
5. Replace the filter if it is damaged or excessively dirty.
6. Rinse sediment from the fuel tank with nonflammable solvent.
7. Insert the fuel filter in the fuel tank, and install the fuel tank cap.

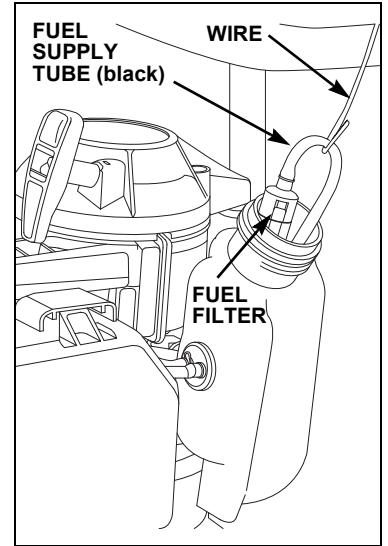

# Transmission Lubrication

The transmission is pre-lubricated at the factory.

At the beginning of each tilling season, or after every 25 hours of use during the season, the transmission should be filled with grease.

Use Shell Alvania EP71125 NLGI #2 extreme pressure lithium grease or equivalent which is usually available in disposable tubes at most hardware or automotive parts stores.

1. Place the tiller on the left side as shown.
2. Remove the lock pin from the right side tine shaft by turning it UP [a] and pulling it out [b] as shown. Wearing heavy gloves, remove both right side tines.
3. Remove any dirt from around the screws and then remove the air vent screw and fill hole screw from the transmission.
4. Fill the transmission by using a grease gun or grease applicator at the fill hole screw opening. Push the gun or applicator against the opening to seal the nozzle of the gun or applicator against the casting embossment. Apply grease until grease begins to come out of the top air vent hole.
5. Reinstall the air vent screw and fill hole screw.
6. Clean the tine shaft and place a few drops of oil on the tine shaft before installing the tines.
7. Wear heavy gloves and reinstall the tines in the reverse order of removal.
8. Install the lock pin [c] through the round side of the tine shaft hole then turn it over [d] to lock it in place.

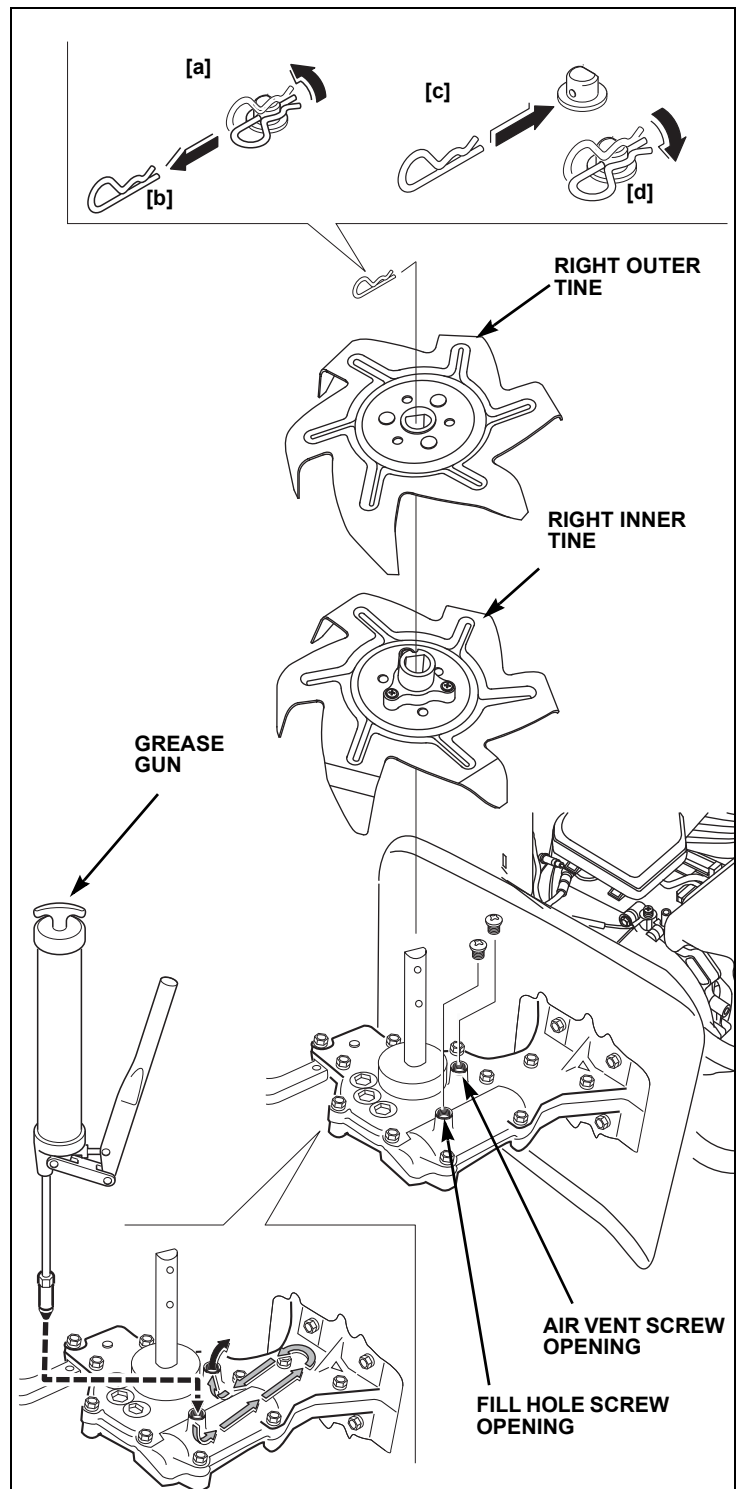

# TRANSPORTING

Follow Honda's recommendations for safe loading, unloading, and transporting your tiller.

## Before Loading

If the engine has been running, allow it to cool for at least 15 minutes before loading the tiller on the transport vehicle. A hot engine and exhaust system can burn you and can ignite some materials.

1. Turn the engine switch to the OFF position.
2. Make sure the fuel cap is securely tightened.
3. Install the wheels in the transport position for greater ground clearance and ease of movement.

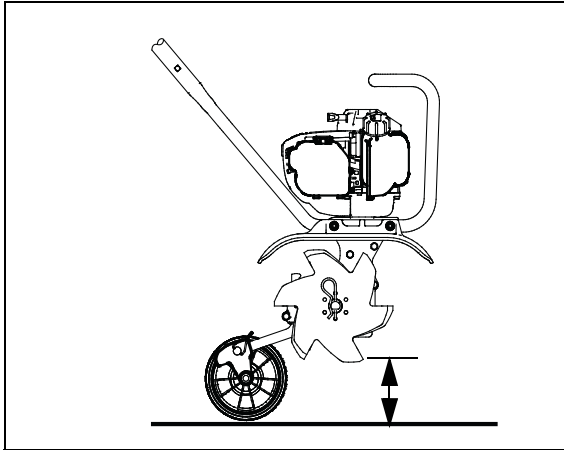

## Loading

If necessary, loosen the handlebar knobs so that the tiller upper handlebar can be collapsed. Be careful that the throttle cable and engine switch wire are not pinched or bent when collapsing the upper handlebar. The cable and wires should be routed on the outside of the handlebar when the handlebar is folded.

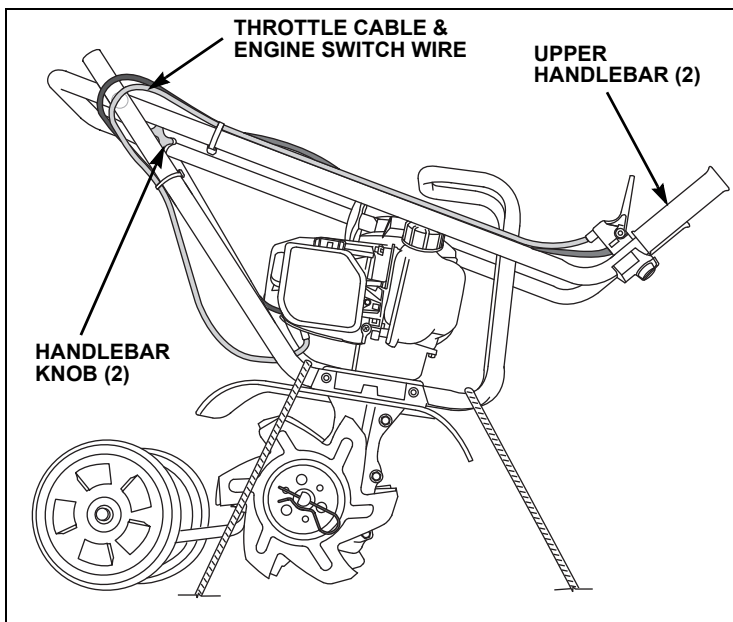

Secure the tiller by tying around the lower handlebars just in front and back of the engine as shown.

# STORAGE

Proper storage preparation is essential for keeping your mini-tiller trouble free and looking good. Follow Honda's recommendations for safe storage of your tiller.

To help keep rust and corrosion from impairing your tillers function and appearance, and to make the engine easier to start after storage, follow the instructions described in this section to:

- Drain or treat the fuel
- Change the oil and coat the engine cylinder
- Clean the tiller and engine
- Choose a storage location
- Install the wheels in the storage position to allow the tiller to be stored in an upright position

## Fuel

See "AVOIDING FUEL-RELATED PROBLEMS" on [page 19](#) for a list of recommended procedures to avoid fuel related problems.

The *DISTRIBUTOR'S LIMITED WARRANTY* ([page 21](#)) does not cover fuel system damage or engine performance problems resulting from neglected storage preparation.

## Draining the Fuel Tank and Carburetor

Draining the fuel tank and carburetor must be done outside.

Disconnect the spark plug cap. Make sure the engine switch is in the OFF position.

Drain fuel from the tank into an approved container. Press the primer bulb several times to draw any fuel out of the carburetor back to the fuel tank, and then drain this fuel from the tank.

## Oil

Change the engine oil (see [page 10](#)).

Add oil in the engine cylinder to prevent rust.

1. Remove the spark plug ([page 11](#)).
2. Pour a 1/4 teaspoon (1 ~ 3 cc) of clean engine oil into the cylinder to keep it from rusting.
3. Pull the starter rope several times to distribute the oil in the cylinder.
4. Reinstall the spark plug.
5. Pull the starter rope slowly until resistance is felt, and then return the starter grip gently. This will close the valves so moisture cannot enter the engine cylinder.

## Cleaning

1. Wash the tiller, including the area around the tiller tines.
2. Wash the engine by hand, and be careful to prevent water from entering the air cleaner.

### NOTICE

*Using a garden hose or pressure washing equipment can force water into the air cleaner. Water in the air cleaner will soak the filter and can enter the carburetor or engine, causing damage.*

3. Water on a hot engine can cause damage. If the engine has been running, allow it to cool for at least 1/2 hour before washing.
4. If using a garden hose or pressure washing equipment to clean the tiller, be careful to avoid getting water into controls and cables, or anywhere near the engine air cleaner or muffler opening.

5. After washing the tiller, wipe dry all accessible surfaces.
6. Start the engine outdoors, and let it run until it reaches normal operating temperature to evaporate any water remaining on the engine.
7. Stop the engine and allow it to cool.
8. After the tiller is clean and dry, touch up any damaged paint, and coat other areas that may rust with a light film of oil.

## Storage Location

If your tiller will be stored with gasoline in the fuel tank and carburetor, it is important to reduce the hazard of gasoline vapor ignition. Select a well-ventilated dry storage area away from any appliance that operates with a flame, such as a furnace, water heater, or clothes dryer. Also avoid any area with a spark-producing electric motor, or where power tools are operated. Allow the engine to cool before storing in any enclosure.

Place the tiller with its wheels on a level surface. Tilting can cause fuel or oil leakage.

With the engine and exhaust system cool, cover the tiller to keep out dust. A hot engine and exhaust system can ignite or melt some materials. Do not use sheet plastic as a dust cover. A nonporous cover will trap moisture around the tiller, promoting rust and corrosion.

## Loading

If necessary, loosen the handlebar knobs so that the tiller upper handlebar can be collapsed. Be careful that the throttle cable and engine switch wire are not pinched or bent when collapsing the upper handlebar. The cable and wires should be routed on the outside of the handlebar when the handlebar is folded.

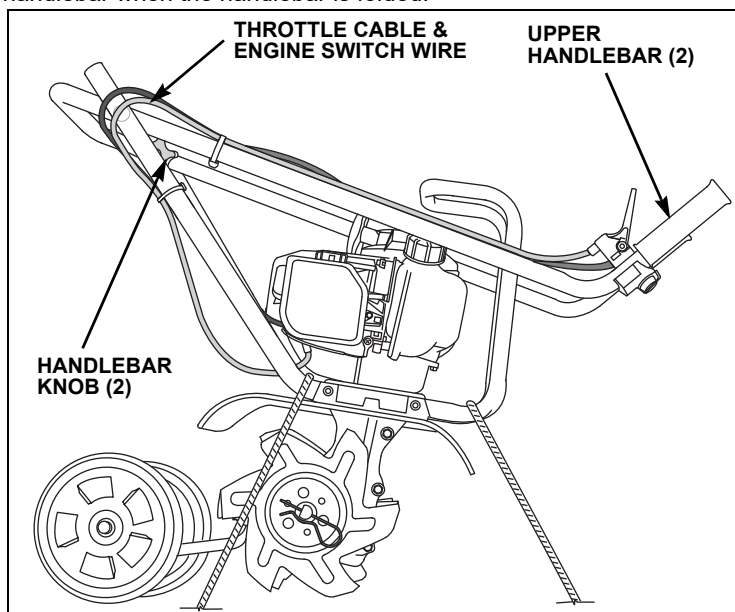

## Removing From Storage

When unfolding the handlebar, do not allow the cable and wires to become pinched between the upper and lower handlebars. Be sure to lock the handlebar knobs to secure the handlebar in the tilling position.

Check your tiller as described in *BEFORE EACH OPERATION* (page 4).

If the cylinder was coated with oil during storage preparation, the engine may smoke briefly at startup. This is normal.

# TROUBLESHOOTING

## Engine Will Not Start

Possible Cause	Correction
Engine switch OFF.	Turn the engine switch ON (page 7).
Choke lever not in CLOSED (N) position (cold engine).	Move the lever to the CLOSED (N) position (page 7).
Out of fuel.	Add fuel and press the priming bulb to fill the carburetor (page 7).
Bad fuel, tiller stored without treating or draining gasoline, refueled with bad gasoline.	Drain the fuel tank. Refuel with fresh gasoline.
Spark plug faulty, fouled, or has incorrect gap.	Gap or replace the spark plug (page 11).
Fuel filter restricted, carburetor malfunction, ignition malfunction, valves stuck, etc.	Have an authorized Honda servicing dealer replace or repair faulty components as needed.

## Loss of Power

Possible Cause	Correction
Air filter dirty or restricted.	Clean or replace the air filter (page 11).
Fuel filter dirty or restricted.	Clean or replace the fuel filter (page 13).
Throttle cable out of adjustment, broken, or bent.	Adjust or replace the cable if necessary (page 13).
Spark plug faulty, fouled, or has incorrect gap.	Gap or replace the spark plug (page 11).

## Tiller Tines Won't Stop Turning

Possible Cause	Correction
Faulty throttle control or cable; throttle cable out of adjustment or bent.	Check throttle control parts, adjust or replace cable if necessary (page 13).
Idle speed is too high.	Adjust the idle speed (page 13) or have an authorized Honda servicing dealer adjust idle speed.
Clutch springs worn or clutch system faulty.	Have an authorized Honda servicing dealer replace clutch springs or replace or repair other clutch system parts.



# TECHNICAL INFORMATION

## Serial Number Locations

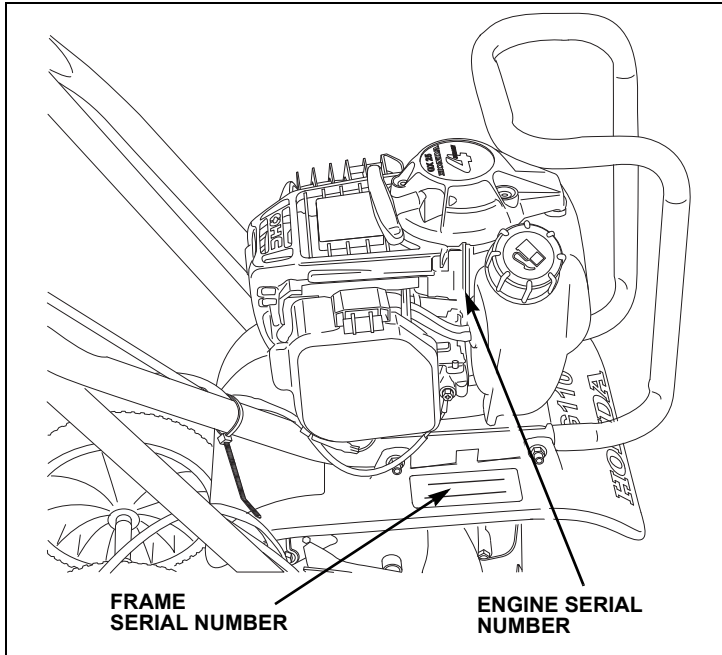

There are two serial numbers, one for the engine and one for the frame. Record the engine and frame serial numbers in the space below. You will need these serial numbers when ordering parts and when making technical or warranty inquiries.

Engine serial number: \_\_\_\_\_

Frame serial number: \_\_\_\_\_

Date of purchase: \_\_\_\_\_

## High Altitude Operation

At high altitudes, the standard carburetor air-fuel mixture will be too rich. Performance will decrease, and fuel consumption will increase. A very rich mixture will also foul the spark plug and cause hard starting. Operation at an altitude that differs from that at which this engine was certified, for extended periods of time, may increase emissions.

High altitude performance can be improved by specific modifications to the carburetor. If you always operate your tiller at altitudes above 2,000 feet (610 meters), have your servicing dealer perform this carburetor modification. This engine, when operated at high altitude with the carburetor modifications for high altitude use, will meet each emission standard throughout its useful life.

Even with carburetor modification, engine horsepower will decrease about 3.5% for each 1,000-foot (300-meter) increase in altitude. The effect of altitude on horsepower will be greater than this if no carburetor modification is made.

### NOTICE

*When the carburetor has been modified for high altitude operation, the air-fuel mixture will be too lean for low altitude use. Operation at altitudes below 2,000 feet (610 meters) with a modified carburetor may cause the engine to overheat and result in serious engine damage. For use at low altitudes, have your servicing dealer return the carburetor to original factory specifications.*

## Emission Control System

### Source of Emissions

The combustion process produces carbon monoxide, oxides of nitrogen, and hydrocarbons. Control of hydrocarbons and oxides of nitrogen is very important because, under certain conditions, they react to form photochemical smog when subjected to sunlight. Carbon monoxide does not react in the same way, but it is toxic.

Honda utilizes appropriate air/fuel ratios and other emissions control systems to reduce the emissions of carbon monoxide, oxides of nitrogen, and hydrocarbons. Additionally, Honda fuel systems utilize components and control technologies to reduce evaporative emissions.

### U.S. EPA and CARB, and Environment and Climate Change Canada (ECCC)

U.S. EPA, California and Canadian regulations require all manufacturers to furnish written instructions describing the operation and maintenance of emissions control systems.

The following instructions and procedures must be followed in order to keep the emissions from your Honda engine within the emissions standards.

### Tampering and Altering

#### NOTICE

*Tampering is a violation of federal and California law.*

Tampering with or altering the emissions control system may increase emissions beyond the legal limit. Among those acts that constitute tampering are:

- Removal or alteration of any part of the intake, fuel, or exhaust systems
- Alterations that would cause the engine to operate outside its design parameters

### Problems That May Affect Emissions

If you are aware of any of the following symptoms, have your engine inspected and repaired by your authorized Honda Power Equipment dealer.

- Hard starting or stalling after starting.
- Rough idle.
- Misfiring or backfiring under load.
- Afterburning (backfiring).
- Black exhaust smoke or high fuel consumption.

### Replacement Parts

The emissions control systems on your new Honda engine were designed, built, and certified to conform with EPA, California (models certified for sale in California only), and Canadian emissions regulations. We recommend the use of Honda Genuine parts whenever you have maintenance done. These original-design replacement parts are manufactured to the same standards as the original parts, so you can be confident of their performance. Honda cannot deny coverage under the emission warranty solely for the use of non-Honda replacement parts or service performed at a location other than an authorized Honda dealership; you may use comparable parts certified by the EPA, CARB or ECCC, as applicable, and have service performed at non-Honda locations. However, the use of replacement parts that are not of the original design and quality may impair the effectiveness of your emissions control system.

A manufacturer of an aftermarket part assumes the responsibility that the part will not adversely affect emissions performance. The manufacturer or rebuilder of the part must certify that use of the part will not result in a failure of the engine to comply with emissions regulations.

## Maintenance

As the power equipment engine owner, you are responsible for completing all required maintenance listed in your owner's manual. Honda recommends that you retain all receipts covering maintenance on your power equipment engine, but Honda cannot deny warranty coverage solely for the lack of receipts or for your failure to ensure that all scheduled maintenance has been completed.

Follow the *MAINTENANCE SCHEDULE* on [page 10](#). Remember that this schedule is based on the assumption that your Honda engine product will be used for its designed purpose. Sustained high-load or high-temperature operation, or use in dusty conditions, will require more frequent service.

## Air Index

### (Models certified for sale in California)

An Air Index Information label is applied to engines certified to an emission durability time period in accordance with the requirements of the California Air Resources Board.

The bar graph is intended to provide you, our customer, the ability to compare the emissions performance of available engines. The lower the Air Index, the less pollution.

The durability description is intended to provide you with information relating to the engine's emission durability period. The descriptive term indicates the useful life period for the engine's emission control system. See your "*EMISSION CONTROL SYSTEM WARRANTY*" on [page 22](#) for additional information.

Descriptive Term	Applicable to Emissions Durability Period
Moderate	50 hours (0 ~ 80 cc) 125 hours (greater than 80 cc)
Intermediate	125 hours (0 ~ 80 cc) 250 hours (greater than 80 cc)
Extended	300 hours (0 ~ 80 cc) 500 hours (greater than 80 cc) 1000 hours (225 cc and greater)

## Specifications

### Engine

Model	GX25T
Type	4-stroke, overhead cam, single cylinder
Description code	GCALT
Displacement	1.5 cu in (25 cc)
Bore & stroke	1.4 x 1.0 in (35 x 26 mm)
Compression ratio	8.0:1
Cooling system	Forced-air
Ignition system	Transistorized magneto
Ignition timing	30° B.T.D.C. (Fixed)
Spark plug	CMR5H (NGK)
Carburetor	Diaphragm type
Air cleaner	Semi-dry type
Lubrication system	Oil mist
Oil capacity	2.7 fl. oz (80 cc)
Recommended operating ambient temperature	23 ~ 104° F (-5 ~ 40° C)
Starting system	Recoil starter
Stopping system	Ignition primary circuit ground
Fuel tank capacity	0.14 gal (0.54 L)
PTO shaft rotation	Counterclockwise (from PTO shaft side)

## Tiller

Model	FG110K1		
Description code	FAAA		
Length x width x height	41.2 x 14.6 x 39.1 in (1,047 x 370 x 994 mm)		
Weight	Dry	with drag bar and wheels	27.3 lb (12.4 kg)
		without drag bar and wheels	24.9 lb (11.3 kg)
	Wet	with drag bar and wheels	28.7 lb (13.0 kg)
		without drag bar and wheels	26.2 lb (11.9 kg)
Drive clutch	Centrifugal mechanical		
Drive clutch engagement speed	4,200 ± 200 rpm		
Tilling width	9 in (230 mm)		
Transmission drive	Worm gear		
Tine number	4 (6 teeth per tine)		

## Maintenance

Fuel	Unleaded gasoline with a pump octane rating of 86 or higher	See <a href="#">page 6</a>
Engine oil	SAE 10W-30 API SJ or later	See <a href="#">page 10</a>
Spark plug type	NGK— CMR5H	See <a href="#">page 11</a>
Standard idle speed	2,900 ~ 3,300 rpm	Shop manual

## Tune-up

Spark plug gap	0.024 ~ 0.028 in (0.60 ~ 0.70 mm)	See <a href="#">page 11</a>
Valve clearance (cold)	Intake: 0.0024 ~ 0.0039 in (0.060 ~ 0.100 mm) Exhaust: 0.0035 ~ 0.0051 in (0.090 ~ 0.130 mm)	See your authorized Honda servicing dealer
Other specifications	No other adjustments needed	

# AVOIDING FUEL-RELATED PROBLEMS

When maintained properly, your Honda tiller should provide years of trouble-free operation. This includes the fuel system. However, gasoline can quickly deteriorate, causing starting or running problems and, in some cases, damage to the fuel system. Most fuel-related problems can be avoided by following the precautions listed below. Fuel system damage and engine performance problems resulting from deteriorated fuel are not covered by the *DISTRIBUTOR'S LIMITED WARRANTY* (see [page 21](#)).

## Follow These Precautions to Prevent Most Fuel-Related Problems

During the Normal Tilling Season	Reason
Do not use gasoline containing more than 10% ethanol.	A high level of ethanol in gasoline attracts water and can corrode or damage the fuel system and cause performance problems.
Store gasoline in a clean, plastic, sealed container approved for fuel storage.  Store your fuel supply container away from direct sunlight; if the container has a vent, keep it closed.	A clean plastic container will prevent rust and metallic contaminants from entering the fuel system.  Gasoline will deteriorate faster when exposed to air and sunlight.
Purchase only enough gasoline to last for 30 to 60 days.  If you purchase enough gasoline to last for more than 60 days, add a fuel stabilizer to your storage tank when you fill it.	Gasoline deteriorates with age, so try to avoid storing it for long periods, especially in summer heat.  Fuel stabilizer will extend the shelf life of gasoline, but it will not reconstitute stale fuel.
When you finish tilling, completely fill the tiller's fuel tank.	If the fuel tank is only partially filled, air in the tank will promote fuel deterioration.

3 to 4 Weeks Before Next Use	Reason
Completely fill the tiller's fuel tank.	If the fuel tank is only partially filled, air in the tank will promote fuel deterioration.

1 to 3 Months Before Next Use	Reason
If you did not add fuel stabilizer to your fuel storage tank when you filled it up, fill your tiller's fuel tank with fresh gasoline.	If the fuel tank is only partially filled, air in the tank will promote fuel deterioration.
Add fuel stabilizer to the tiller's tank according to the stabilizer manufacturer's instructions.	Fuel stabilizer will extend the life of gasoline, but it will not reconstitute stale gasoline.
Run the engine outdoors for 10 minutes.	To make sure treated gasoline has replaced untreated gasoline throughout the fuel system.

More Than 3 Months Before Next Use	Reason
Drain the fuel tank into an approved container and then run the engine until the engine stops. Do not allow gasoline to remain in your tiller for more than 3 months of inactivity.	All fuel stabilizers have a shelf life. It is good practice to empty the fuel system for long-term inactivity.

We recommend Pro Honda Fuel Stabilizer, that has improved formulation with added corrosion protection ([page 20](#)).

# CUSTOMER INFORMATION

## Parts, Accessories, and Service Items

Contact an authorized Honda servicing dealer to purchase any of these (or other) Honda Genuine items for your tiller.

### Replacement Parts

Item	Part Number	Notes
Spark plug	31915-Z0H-003	NGK (brand) CMR5H
Air filter	17211-Z0H-800	

### Accessories

Item	Part Number	Notes
Spark arrester	18310-Z0H-841	Muffler
	18350-Z0H-820	Arrester
	93901-22010	Screw
Digging Tines Attachment	06726-V25-010	Four digging tines that are designed to cut through sod and hard compacted soil or grass covered areas.
Aerator Attachment	06727-V25-000	Four 10-tooth, 8-1/2 inch heavy gauge, tempered steel aerating tines that make slits in the soil. These slits allow water, air, and the proper nutrients to reach the grass roots.
Border/Edger Attachment	06728-V25-000	A 10-tooth, 8-1/2 inch edger tine of heavy gauge tempered steel blade that neatly edges your garden, patio, walkways, driveways, and flower beds
De-thatcher	06720-V25-000	Includes debris shield.

### Service Items

Item	Part Number	Notes
SAE 10W-30 engine oil	08207-10W30	Honda Genuine recommended oil 1 qt.
Fuel stabilizer	08732-0800	For long term storage 8 oz.
Honda air filter oil (MOTUL)	08207-MTL-100	4 oz bottle
No-Spill <sup>®</sup> gas can	06176-1450C 06176-1405-C6 06176-1415-C6	5 gallon 2 1/2 gallon 1 1/4 gallon

© NO-SPILL is a registered trademark of NoSpill LLC.

## Dealer Locator Information

To find an Authorized Honda Servicing Dealer anywhere in the United States, visit [powerequipment.honda.com](http://powerequipment.honda.com) and click on Find a Dealer.

## How to Contact Honda

Honda Power Equipment dealership personnel are trained professionals. They should be able to answer any question you may have. If you encounter a problem that your dealer does not solve to your satisfaction, please discuss it with the dealership's management. The Service Manager or General Manager can help. Almost all problems are solved in this way.

If you are dissatisfied with the decision made by the dealership's management, contact the Honda Power Equipment Customer Relations Office. You can write:

**American Honda Motor Co., Inc.**  
Power Sports and Products Division  
Customer Relations Office  
4900 Marconi Drive  
Alpharetta, GA 30005-8847

Or telephone: (770) 497-6400 M-F, 9:00 a.m. - 7:30 p.m. ET

When you write or call, please give us this information:

- Model and serial numbers ([page 17](#))
- Name of the dealer who sold the tiller to you
- Name and address of the dealer who services your tiller
- Date of purchase
- Your name, address, and telephone number
- A detailed description of the problem

## Honda Publications

These publications will give you information for maintaining and repairing your tiller.

### Owner's Manual

Keep this owner's manual handy so you can refer to it at any time. Consider this owner's manual a permanent part of the tiller please give it to the new owner if you resell the tiller.

The information and specifications included in this publication were in effect at the time of approval for printing. American Honda Motor Co., Inc. reserves the right, however, to discontinue or change specifications or design at any time without notice and without incurring any obligation whatever. No part of this publication may be reproduced without written permission.

### Shop Manual

This manual covers complete maintenance and overhaul procedures. It is intended to be used by a skilled technician. Available for purchase by visiting [publications.powerequipment.honda.com](http://publications.powerequipment.honda.com).

### Parts Catalog

This manual provides complete, illustrated parts lists for your tiller. Visit [powerequipment.honda.com](http://powerequipment.honda.com) and then click on *Support* for free online access to parts catalog. It is also available for purchase in paper form by visiting [publications.powerequipment.honda.com](http://publications.powerequipment.honda.com).

### Frequently Asked Questions

The Honda Power Equipment web site provides additional information for users of Honda power equipment. Visit [powerequipment.honda.com](http://powerequipment.honda.com) and click on FAQs or scan the QR code shown.





# DISTRIBUTOR'S LIMITED WARRANTY

## Honda Power Equipment

This warranty is limited to the following Honda Power Equipment product when distributed by American Honda Motor Co., Inc., Power Sports and Products Division, 4900 Marconi Drive, Alpharetta, Georgia 30005. **The following warranty applies to products manufactured on or after April 1, 2023.**

PRODUCTS COVERED BY THIS WARRANTY	LENGTH OF WARRANTY (from date of original retail purchase)	
	PRIVATE RESIDENTIAL <sup>(1)</sup>	COMMERCIAL/ RENTAL/INSTITUTIONAL
FG110	24 months	12 months

<sup>(1)</sup> Private residential: Used in maintaining owner's primary and/or secondary residence. Any other use, including but not limited to informal "for hire" use, is considered commercial/rental/institutional use.

### To Qualify for This Warranty:

The product must be purchased in the United States, Puerto Rico, or the U.S. Virgin Islands from American Honda or a dealer authorized by American Honda to sell those products. This warranty applies to first retail purchaser and each subsequent owner during the applicable warranty time period, unless noted otherwise.

### What American Honda Will Repair or Replace Under Warranty:

American Honda will repair or replace, at its option, any part that is proven to be defective in material or workmanship under normal use during the applicable warranty time period. Warranty repairs and replacements will be made without charge for parts or labor. Anything replaced under warranty becomes the property of American Honda Motor Co., Inc. All parts replaced under warranty will be considered as part of the original product, and any warranty on those parts will expire coincident with the original product warranty.

### To Obtain Warranty Service:

You must, at your expense, take the Honda Power Equipment product, accessory, replacement part, apparel, or the power equipment on which the accessory or replacement part is installed, and proof of purchase to any Honda Power Equipment dealer in the United States, Puerto Rico, or the U.S. Virgin Islands who is authorized to sell and/or service that product, during the dealer's normal business hours. To locate a dealer near you, visit our web site at <http://powerequipment.honda.com> and click on Find a Dealer. If you are unable to obtain warranty service or are dissatisfied with the warranty service you receive, contact the owner of the dealership involved; normally this will resolve the problem. However, if you should require further assistance, write or call the Power Equipment Customer Relations Department of American Honda Motor Co., Inc. See "How to Contact Honda" on [page 20](#).

### Exclusions:

- Any damage or deterioration resulting from the following:
  - Neglect of the periodic maintenance as specified in this manual
  - Improper repair or maintenance
  - Operating methods other than those indicated in the product owner's manual
  - Increasing engine speed beyond factory specification
  - The use of non-genuine Honda parts, accessories, lubricants, and fluids other than those approved by Honda
  - Exposure of the product to soot and smoke, chemical agents, bird droppings, sea water, salt or other corrosive environments
  - Collision, fuel contamination or deterioration, neglect, unauthorized alteration, misuse, incorporation or use of unsuitable attachments or parts
  - Normal wear and tear (including, but not limited to, normal fading of painted or plated surfaces, sheet peeling, and other natural deterioration)
- Consumable parts: Honda does not warrant parts deterioration due to normal wear and tear. The following parts are not covered by this warranty unless they are needed during another repair covered under this warranty: spark plug, fuel filter, air cleaner element, clutch disc, tire, wheel bearing, recoil starter rope, cable, belt, cutter blade, oil, and grease.
- Cleaning, adjustment, and normal periodic maintenance work (carburetor cleaning, engine oil draining, blade sharpening, belt and cable adjustments).
- Any product that has ever been declared a total loss or sold for salvage by a financial institution or insurer.
- Auger and paddle assemblies, skid shoes, and scraper bars of snow throwers/snow blowers, tiller tines of roto-tillers, and mower blades and mower deck housings are specifically not warranted against impact damage including, but not limited to, abrasive damage.

### Disclaimer of Consequential Damage and Limitation of Implied Warranties:

American Honda disclaims any responsibility for loss of time or use of the product, transportation, commercial loss, or any other incidental or consequential damage. Any implied warranties are limited to the duration of this written limited warranty. Some states do not allow limitations on how long an implied warranty lasts and/or do not allow the exclusion or limitation of incidental or consequential damages, therefore the above exclusions and limitations may not apply to you. This warranty gives you specific legal rights, and you may also have other rights, which vary from state to state.

### Honda Parts, Accessories, and Apparel

This warranty is limited to Honda Power Equipment parts, accessories, and apparel when distributed by American Honda Motor Co., Inc., 4900 Marconi Drive, Alpharetta, Georgia 30005-8847.

PRODUCTS COVERED BY THIS WARRANTY	LENGTH OF WARRANTY (from date of original retail purchase)	
	PRIVATE RESIDENTIAL	COMMERCIAL/RENTAL/ INSTITUTIONAL
Parts	6 months	3 months
Accessories	12 months	3 months
Apparel	6 months	3 months

### To Qualify for This Warranty:

The parts, accessories, or apparel must be purchased from American Honda or a dealer authorized by American Honda to sell those products in the United States, Puerto Rico, and the U.S. Virgin Islands. Parts and Accessories must be purchased for installation on original Honda equipment or engines to be eligible for warranty coverage. Installing parts and accessories on non-Honda products or engines voids this warranty.

You must be the first retail purchaser. This warranty is not transferable to subsequent owners.

### What American Honda Will Repair or Replace Under Warranty:

American Honda will repair or replace, at its option, any Honda Power Equipment parts, accessories, replacement parts, or apparel that are proven to be defective in material or workmanship under normal use during the applicable warranty time period. Anything replaced under warranty becomes the property of American Honda Motor Co., Inc. The warranty on all parts, accessories, and apparel replaced under warranty will expire coincident with the original warranty on the replaced parts, accessories, or apparel.

Parts and accessories installed by a dealer who is authorized by American Honda to sell them will be repaired or replaced under warranty without charge for parts or labor. If installed by anyone else, parts and accessories will be repaired or replaced under warranty without charge for parts, but any labor charges will be the responsibility of the purchaser.

Apparel will be repaired or replaced under warranty without any charge.

### To Obtain Warranty Service:

You must, at your expense, take the Honda Power Equipment part, accessory, apparel or the Honda Power Equipment on which the part or accessory is installed, and proof of purchase to any Honda Power Equipment dealer in the United States, Puerto Rico, or the U.S. Virgin Islands who is authorized to sell that product, during the dealer's normal business hours. To locate a dealer near you, visit our web site at [PowerEquipment.Honda.com](http://PowerEquipment.Honda.com) and click on Find a Dealer.

If you are unable to obtain warranty service or are dissatisfied with the warranty service you receive, contact the owner of the dealership involved; normally this will resolve the problem. However, if you should require further assistance, write or call the Power Equipment Customer Relations Department of American Honda Motor Co., Inc. See "How to Contact Honda" on [page 20](#).

### Exclusions:

This warranty does not extend to parts, accessories, or apparel affected or damaged by collision, normal wear, use in an application for which the product was not designed or any other misuse, neglect, incorporation or use of unsuitable attachments or parts, unauthorized alteration, improper installation, or any causes other than defects in material or workmanship of the product. Installing parts and accessories on non-Honda products or engines voids this warranty.

### Disclaimer of Consequential Damage and Limitation of Implied Warranties:

American Honda disclaims any responsibility for loss of time or use of the product, or the power equipment on which the product is installed, transportation, commercial loss, or any other incidental or consequential damage. Any implied warranties are limited to the duration of this written warranty. Some states do not allow limitations on how long an implied warranty lasts and/or do not allow the exclusion or limitation of incidental or consequential damages, so the above exclusions and limitations may not apply to you.

This warranty gives you specific legal rights, and you may also have other rights which vary from state to state.

PWL50623-Y

# EMISSION CONTROL SYSTEM WARRANTY

Your new Honda Power Equipment engine complies with the U.S. EPA, Environment Canada, and State of California (models certified for sale in California only) emission regulations. American Honda Motor Co., Inc. provides the emission warranty coverage for engines in the United States and its territories. Honda Canada Inc. provides the emission warranty for engines in the 13 provinces and territories of Canada. In the remainder of this Emission Control System Warranty, American Honda Motor Co., Inc. and Honda Canada Inc. will be referred to as Honda.

## CALIFORNIA EXHAUST AND EVAPORATIVE EMISSIONS CONTROL WARRANTY STATEMENT

### YOUR WARRANTY RIGHTS AND OBLIGATIONS

The California Air Resources Board and Honda are pleased to explain the exhaust and evaporative emissions ("emissions") control system warranty on your 2024 and later Honda Power Equipment engine. In California, new equipment that use small off-road engines must be designed, built, and equipped to meet the State's stringent anti-smog standards. Honda must warrant the emissions control system on your power equipment engine for the periods of time listed below provided there has been no abuse, neglect, or improper maintenance of your small off-road engine or equipment leading to the failure of the emissions control system.

Your emissions control system may include parts such as the carburetor or fuel-injection system, the ignition system, catalytic converter, fuel tanks, fuel lines (for liquid fuel and fuel vapors), fuel caps, valves, canisters, filters, clamps and other associated components. Also included may be hoses, belts, connectors, and other emission-related assemblies (see the adjacent column for additional covered parts).

Where a warrantable condition exists, Honda will repair your power equipment engine at no cost to you including diagnosis, parts and labor.

### MANUFACTURER'S WARRANTY COVERAGE:

The exhaust and evaporative emissions control system on your Honda power equipment engine is warranted for two years. If any emissions-related part on your Honda power equipment engine is defective, the part will be repaired or replaced by Honda.

### OWNER'S WARRANTY RESPONSIBILITY:

- As the power equipment engine owner, you are responsible for the performance of the required maintenance listed in your owner's manual. Honda recommends that you retain all receipts covering maintenance on your power equipment engine, but Honda cannot deny warranty coverage solely for the lack of receipts or for your failure to ensure the performance of all scheduled maintenance.
- As the power equipment engine owner, you should however be aware that Honda may deny you warranty coverage if your power equipment engine or a part has failed due to abuse, neglect, improper maintenance, or unapproved modifications.
- You are responsible for presenting your power equipment engine to a Honda Power Equipment servicing dealer as soon as the problem exists. The warranty repairs shall be completed in a reasonable amount of time, not to exceed 30 days.

If you have any questions regarding your warranty rights and responsibilities, you should contact the Honda office in your region:

**American Honda Motor Co., Inc.**  
Power Equipment  
Customer Relations  
4900 Marconi Drive  
Alpharetta, Georgia 30005-8847  
Telephone: (888) 888-3139  
Email: powerequipmentemissions@ahm.honda.com

or  
**Honda Canada Inc.**  
Power Equipment  
Customer Relations  
180 Honda Blvd.  
Markham, ON, L6C 0H9  
Telephone: (888) 946-6329

### YOUR WARRANTY RIGHTS AND OBLIGATIONS

#### Other States, U.S. territories, and Canada:

In other areas of the United States and in Canada, your engine must be designed, built, and equipped to meet the U.S. EPA and Environment Canada emission standards for spark-ignited engines at or below 19 kilowatts.

Specific Honda products that do not meet the California emissions regulations can be identified by a "California: Not for sale or use" or "California: Only for use in Farming or Construction Equipment" decal.

#### All of the United States and Canada:

The exhaust and evaporative emissions control system on your Honda power equipment engine sold in the United States and Canada is warranted for two years from the date of delivery to the ultimate purchaser or the length of the Honda Distributor's Limited Warranty, whichever is longer. This warranty is transferable to each subsequent purchaser for the duration of the warranty period.

If any emissions-related part on your Honda power equipment engine is defective, the part will be repaired or replaced by Honda. All defective parts replaced under this warranty become the property of Honda. Only Honda

approved replacement parts may be used in the performance of any warranty repairs and must be provided without charge to the owner. A list of warranted parts is shown in the table below. All emission related parts are under warranty for the remainder of the warranty period. Normal maintenance items, such as spark plugs and filters, that are on the warranted parts list are warranted up to their required replacement interval only.

Honda will also replace other engine components damaged by a failure of any warranted part during the warranty period. Honda cannot deny coverage under the emission warranty solely for use of non-Honda replacement parts or service performed at a location other than an authorized Honda dealership; however, use of a part that is not functionally identical to the original equipment part in any respect that may in any way affect emissions (including durability) could result in denial of coverage. If such a non-Honda replacement part is used in the repair or maintenance of your engine, and an authorized Honda dealer determines it is defective or causes a failure of a warranted part, your claim for repair of your engine may be denied. If the part in question is not related to the reason your engine requires repair, your claim will not be denied.

### TO OBTAIN WARRANTY SERVICE:

You must, at your own expense, take your Honda Power Equipment engine or the product on which it is installed, along with your sales registration card or other proof of original purchase date, to any Honda Power Equipment dealer who is authorized by Honda to sell and service that Honda product during their normal business hours. Claims for repair or adjustment found to be caused solely by defects in material or workmanship will not be denied because the engine was not properly maintained and used.

If you are unable to obtain emission warranty service or are dissatisfied with the warranty service you received, contact the owner of the dealership involved. Normally this should resolve your problem. However, if you require further assistance, contact the Honda office in your region using the information shown in the adjacent column.

### EXCLUSIONS:

Failures other than those resulting from defects in material or workmanship are not covered by this warranty. This warranty does not extend to emission control systems or parts that are affected or damaged by owner abuse, neglect, improper maintenance, or unapproved modifications.

This warranty does not cover replacement of expendable maintenance items made in connection with required maintenance service after the item's first scheduled replacement as listed in the maintenance section of the product owner's manual, such as: spark plugs and filters.

### DISCLAIMER OF CONSEQUENTIAL DAMAGE AND LIMITATION OF IMPLIED WARRANTIES:

American Honda Motor Co., Inc. and Honda Canada Inc. disclaim any responsibility for incidental or consequential damages such as loss of time or the use of the power equipment, or any commercial loss due to the failure of the equipment; and any implied warranties are limited to the duration of this written warranty. This warranty is applicable only where the California, U.S. EPA, or Environment Canada emission control system warranty regulation is in effect.

### EMISSION CONTROL SYSTEM WARRANTY PARTS:

SYSTEMS COVERED BY THIS WARRANTY:	PARTS DESCRIPTION:
Fuel Metering	Carburetor assembly (includes starting enrichment system), Oxygen sensor, Throttle body, Engine temperature sensor, Engine control module, Fuel injector, Fuel regulator, Intake manifold
Evaporative	Fuel tank, Fuel cap, Fuel lines (for liquid and fuel vapors), Carbon canister, Canister mounting brackets, Fuel line fittings, Fuel strainer, Fuel valve, Fuel pump, Fuel hose joint, Canister purge port connector
Exhaust	Catalyst, Exhaust pipe, Muffler (with catalyst), Exhaust manifold
Air Induction	Air cleaner case, Air cleaner element*
Ignition	Flywheel comp., Flywheel magneto, Ignition pulse generator, Crankshaft position sensor, Power coil, Ignition coil assembly, Ignition control module, Spark plug cap, Spark plug*
Crankcase Emission Control	Crankcase breather tube, Breather valve assembly, Oil filler cap
Miscellaneous Parts	Tubing, fittings, seals, gaskets, and clamps associated with these listed systems.

\* Covered up to the first required replacement only. See the Maintenance Schedule on [page 10](#). PWL50975-Z

# PRODUCT REGISTRATION

Thank you for choosing Honda. To ensure you receive important service information in the event of a product update or recall, please register your mini-tiller within 30 days of purchase.

From time to time, American Honda conducts sales promotions that require you to register your tiller within 30 days of purchase. If you purchased your Honda mini-tiller during one of these promotions, you must register your tiller within 30 days.

Your information will remain confidential. It will not be released to any other company or organization.

Failure to register your tiller does not diminish your warranty rights.

Please complete and mail the postage paid card, scan the QR code, or register online at [powerequipment.honda.com/reg](http://powerequipment.honda.com/reg) as shown on the next page.



Scan this QR code to register your tiller.



(example)

MODEL: XXXX XXXX  
 SERIAL NO: FAA/-XXXXXX

Print the 7-digit serial number here.

Serial number	* Dealer Store number	* Dealer ZIP code
FAAA-		
Owner's Last Name	First Name	*If available
Company Name <i>(commercial/rental users)</i>	Telephone	
	( ) -	
Address		
City	State	ZIP Code
		-
E-mail address		
Date of Purchase	Purchased Via <i>(check one)</i>	
— —	In Store Online	
MONTH DAY YEAR		
Application <i>(check one)</i>	Commercial <i>(professional use)</i>	Non-commercial <i>(private, homeowner use)</i>
		Rental <i>(for-hire use)</i>

# Register Your Product Online

1. Go to [powerequipment.honda.com/reg](https://powerequipment.honda.com/reg) to register your unit.
2. Enter your serial number, and then click Submit.
3. Complete the required information and click Submit. It's that simple!

**HONDA** POWER EQUIPMENT  
GENERATORS ▾ LAWN & GARDEN ▾ PUMPS ▾ SNOW BLOWERS ▾

Home ▸ Product Registration

Find a Dealer Search Support Special Offers Financing

### Product Registration

Congratulations on the purchase of your new Honda Product! Thank you for registering online. Your information will remain confidential. It will not be released to any other company or organization.

Please enter your serial number to get started.

Prefix (i.e. MANA) Number (7 digits) **Submit**

Serial Number (i.e. MANA-1234567)\*  
[Need help finding your serial number?](#)

Serial Number (i.e. MANA-1234567)\*  
[Need help finding your serial number?](#)

Title First Name\* MI Last Name\* Suffix

Address Line 1\* Address Line 2

City\* State\* Zip Code\*

Email\* Confirm Email\* Phone Number\*

Date Purchased\* Product Use\* Location Purchased\* Purchased Via\*

I'm not a robot hCAPTCHA  
Prevent Spam

**Submit**

## Product Registration



NO POSTAGE  
NECESSARY  
IF MAILED  
IN THE  
UNITED STATES

**BUSINESS REPLY MAIL**

FIRST-CLASS MAIL PERMIT NO. 117 ALPHARETTA GA

POSTAGE WILL BE PAID BY ADDRESSEE

Power Equipment Division  
American Honda Motor Co., Inc.  
4900 Marconi Dr  
Alpharetta GA 30005-9956

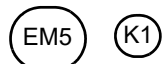

NCM.2024.01  
PRINTED IN U.S.A.

