

HONDA
MARINE

BF2D
Owner's Manual

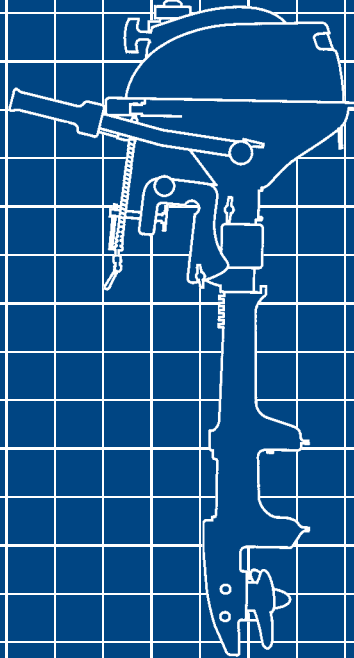



WARNING:



The engine exhaust from this product contains chemicals known to the State of California to cause cancer, birth defects, or other reproductive harm.

Keep this owner's manual handy, so you can refer to it at any time. This owner's manual is considered a permanent part of the outboard motor and should remain with the outboard motor if resold.

The information and specifications included in this publication were in effect at the time of approval for printing. Honda Motor Co., Ltd. reserves the right, however, to discontinue or change specifications or design at any time without notice and without incurring any obligation whatever. No part of this publication may be reproduced without written permission.

INTRODUCTION

Congratulations on your selection of a Honda outboard motor. We are certain you will be pleased with your purchase of one of the finest outboard motors on the market.

We want to help you get the best results from your new outboard motor and to operate it safely. This manual contains the information on how to do that; please read it carefully.

As you read this manual you will find information preceded by a

NOTICE symbol. That information is intended to help you avoid damage to your outboard motor, other property, or the environment.

We suggest you read the warranty policy to fully understand its coverage and your responsibilities of ownership.

When your outboard motor needs scheduled maintenance, keep in mind that your Honda marine dealer is specially trained in servicing Honda outboard motors. Your Honda marine dealer is dedicated to your satisfaction and will be pleased to answer your questions and concerns.

© 2004 Honda Motor Co., Ltd. All Rights Reserved

INTRODUCTION

A FEW WORDS ABOUT SAFETY

Your safety and the safety of others are very important. And using this outboard motor safely is an important responsibility.

To help you make informed decisions about safety, we have provided operating procedures and other information on labels and in this manual. This information alerts you to potential hazards that could hurt you or others.

Of course, it is not practical or possible to warn you about all the hazards associated with operating or maintaining an outboard motor. You must use your own good judgment.

You will find important safety information in a variety of forms, including:

- **Safety Labels** — on the outboard motor.
- **Safety Messages** — preceded by a safety alert symbol  and one of three signal words, DANGER, WARNING, or CAUTION.

These signal words mean:

 **DANGER** You **WILL** be **KILLED** or **SERIOUSLY HURT** if you don't follow instructions.

 **WARNING** You **CAN** be **KILLED** or **SERIOUSLY HURT** if you don't follow instructions.

 **CAUTION** You **CAN** be **HURT** if you don't follow instructions.

- **Safety Headings** — such as *IMPORTANT SAFETY INFORMATION*.
- **Safety Section** — such as *OUTBOARD MOTOR SAFETY*.
- **Instructions** — how to use this outboard motor correctly and safely.

This entire book is filled with important safety information — please read it carefully.

CONTENTS

OUTBOARD MOTOR SAFETY.....	6	OTHER FEATURES	16
IMPORTANT SAFETY INFORMATION.....	6	Centrifugal Clutch (SCHA/LCHA type).....	16
SAFETY LABEL LOCATIONS.....	8	Oil Level Inspection Window.....	16
CONTROLS AND FEATURES	9	Anode	16
CONTROLS AND FEATURE		INSTALLATION.....	17
IDENTIFICATION CODES	9	POWER REQUIREMENTS.....	17
COMPONENT AND CONTROL LOCATIONS	10	INSTALLATION POSITION	17
CONTROLS.....	11	ATTACHMENT	18
Engine Stop Switch and Switch Clip.....	11	TRANSOM ANGLE ADJUSTMENT	19
Choke Knob	11	BEFORE OPERATION.....	20
Throttle lever (SA type only).....	12	ARE YOU READY TO GET UNDER WAY ?	20
Throttle Grip (SHA/SCHA/LCHA type).....	12	IS YOUR OUTBOARD MOTOR	
Throttle Friction Knob		READY TO GO ?	20
(SHA/SCHA/LCHA type).....	12		
Fuel Valve Lever.....	13		
Recoil Starter Grip	13		
Engine Cover Retaining Strap	13		
Transom Angle Adjusting Bolt.....	14		
Tilt Lever.....	14		
Steering Friction Bolt.....	15		
Clamp Screws.....	15		
Fuel Cap Vent Knob	15		

CONTENTS

OPERATION	22	SERVICING YOUR OUTBOARD MOTOR	36
SAFE OPERATING PRECAUTIONS	22	THE IMPORTANCE OF MAINTENANCE	36
BREAK-IN PROCEDURE.....	22	MAINTENANCE SAFETY	37
TRANSOM ANGLE ADJUSTMENT	22	TOOL KIT AND EMERGENCY STARTER	
STARTING THE ENGINE	23	ROPE.....	38
EMERGENCY STARTING.....	26	MAINTENANCE SCHEDULE	39
STOPPING THE ENGINE.....	28	ENGINE COVER REMOVAL AND	
Emergency Engine Stopping	28	INSTALLATION.....	41
Normal Engine Stopping.....	28	Engine Oil Level Check	41
THROTTLE OPERATION	30	Engine Oil Change	41
REVERSING THE OUTBOARD MOTOR	31	Engine Oil Recommendations	43
STEERING	32	Lubrication Points	44
CRUISING	33	Spark Plug Service	45
MOORING, BEACHING, LAUNCHING.....	34	REFUELING.....	47
		FUEL RECOMMENDATIONS.....	48
		Recoil Starter Rope Inspection	49
		Anode Replacement	49
		Propeller Replacement	50

CONTENTS

STORAGE	51	TECHNICAL AND CONSUMER INFORMATION...	62
STORAGE PREPARATION	51	TECHNICAL INFORMATION.....	62
Cleaning	51	Serial Number Locations	62
Fuel.....	51	Carburetor Modification for High Altitude	
Adding a Fuel Stabilizer	52	Operation.....	63
Draining the Fuel Tank and Carburetor.....	52	Oxygenated Fuels.....	64
Engine Oil	53	Emission Control System Information	65
STORAGE PRECAUTIONS	53	Star Label	67
REMOVAL FROM STORAGE.....	54	Specifications	69
TRANSPORTING	55	CONSUMER INFORMATION	70
WITH OUTBOARD MOTOR INSTALLED		Honda Publications	70
ON BOAT	55	Customer Service Information.....	70
WITH OUTBOARD MOTOR REMOVED		Distributors Limited Warranty – 2005.....	71
FROM BOAT	55	Emission Control System Warranty	73
TAKING CARE OF UNEXPECTED PROBLEMS.....	56	WIRING DIAGRAM.....	75
ENGINE WILL NOT START.....	56	INDEX.....	76
HARD STARTING OR STALLS AFTER			
STARTING.....	58		
ENGINE WILL NOT DRIVE THE PROPELLER...	59		
SUBMERGED MOTOR	60		

OUTBOARD MOTOR SAFETY

IMPORTANT SAFETY INFORMATION

Honda BF2D outboard motor is designed for use with boats that have a suitable manufacturer's power recommendation. Other uses can result in injury to the operator or damage to the outboard motor and other property.

Most accidents can be prevented if you follow all instructions in this manual and on the outboard motor. The most common hazards are discussed below, along with the best way to protect yourself and others.

Operator Responsibility

- It is the operator's responsibility to provide the necessary safeguards to protect people and property. Know how to stop the engine quickly in case of emergency. Understand the use of all controls.
 - Stop the engine immediately if anyone falls overboard, and do not run the engine while the boat is near anyone in the water.
 - Always stop the engine if you must leave the controls for any reason.
- Attach the emergency stop switch lanyard securely to the operator.
 - Always wear a PFD (Personal Flotation Device) while on the boat.
 - Familiarize yourself with all laws and regulations relating to boating and the use of outboard motors.
 - Be sure that anyone who operates the outboard motor receives proper instruction.
 - Be sure the outboard motor is properly mounted on the boat.
 - Do not remove the engine cover while the engine is running.

Refuel With Care

- Gasoline is extremely flammable, and gasoline vapor can explode. Refuel outdoors, in a well-ventilated area, with the engine stopped. Never smoke near gasoline, and keep other flames and sparks away.
- Refuel carefully to avoid spilling fuel. Avoid overfilling the fuel tank.
- After refueling, tighten the filler cap securely. If any fuel is spilled, make sure the area is dry before starting the engine.

Carbon Monoxide Hazard

Exhaust gas contains poisonous carbon monoxide. Avoid inhalation of exhaust gas. Never run the engine in a closed garage or confined area.

OUTBOARD MOTOR SAFETY

SAFETY LABEL LOCATIONS

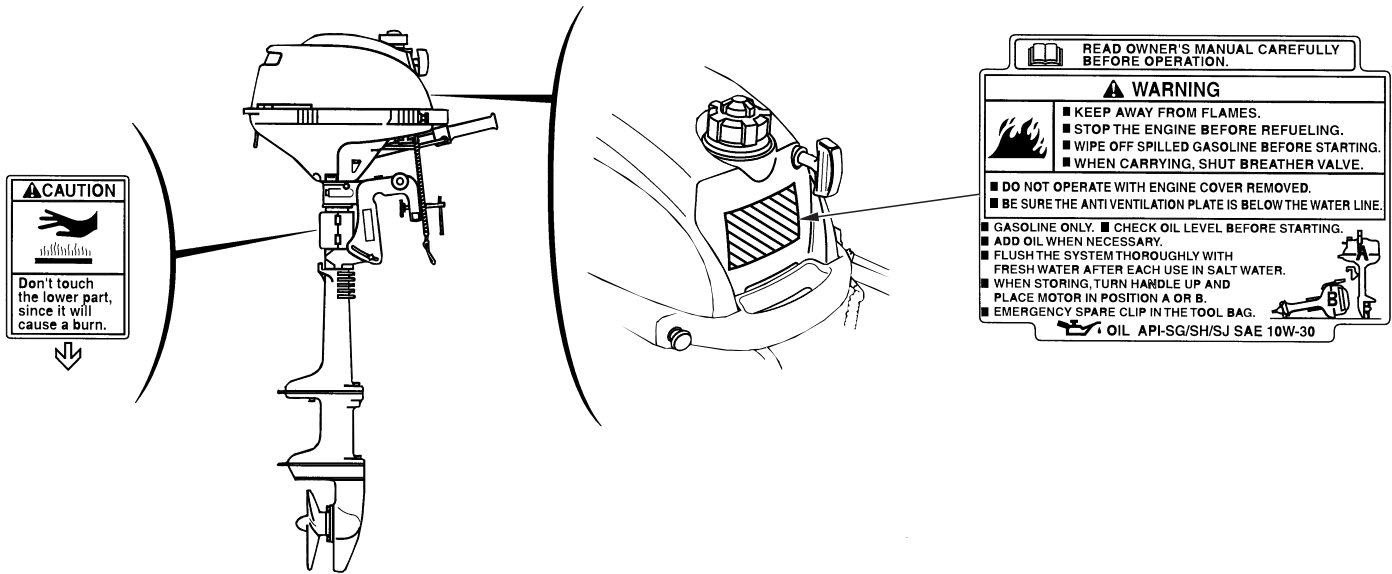

The labels shown here contain important safety information. Please read them carefully. These labels are considered permanent parts of your outboard motor. If a label comes off or becomes hard to read, contact an authorized Honda Marine servicing dealer for a replacement.

CONTROLS AND FEATURES

CONTROL AND FEATURE IDENTIFICATION CODES

Model	BF2D			
Type	SA	SHA	SCHA	LCHA
Shaft Length	S	●	●	
	L			●
Throttle Lever	●			
Throttle Grip		●	●	●
Centrifugal Clutch			●	●

Refer to this chart for an explanation of the Type Codes used in this manual to identify control and feature applications.

TYPE CODE(example)

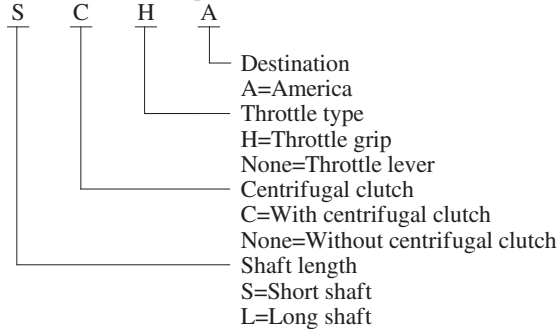

CONTROLS AND FEATURES

COMPONENT AND CONTROL LOCATIONS

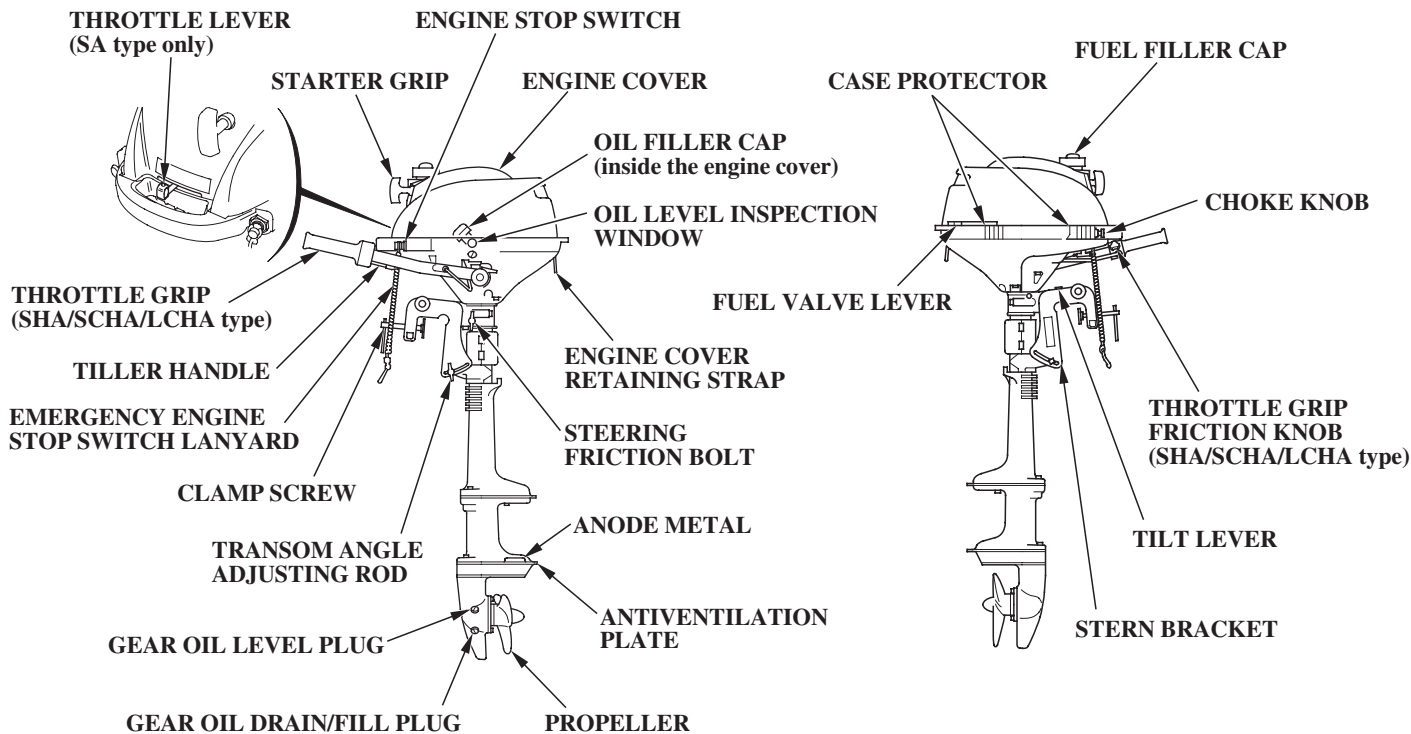

LCHA type is shown

CONTROLS

Engine Stop Switch and Switch Clip

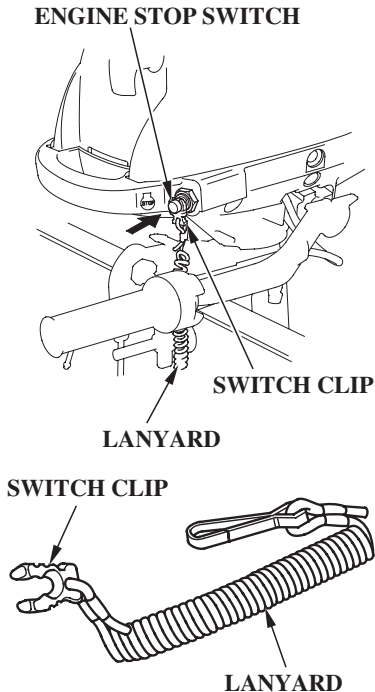

The engine stop switch controls normal engine stopping and emergency engine stopping.

The switch clip must be inserted in the engine stop switch in order for the engine to start and run. The lanyard should be attached to the operator's PFD (Personal Flotation Device) or worn around the wrist as shown (p. 23).

When used as described, the engine stop switch and lanyard system stops the engine if the operator falls away from the controls.

A spare switch clip is supplied with the tool kit.

Choke Knob

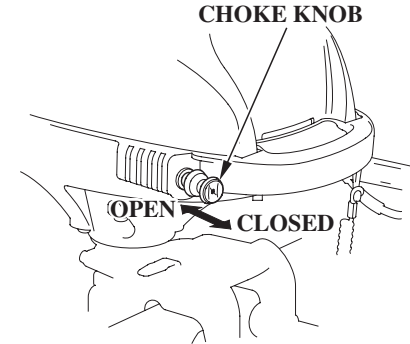

The choke knob opens and closes the choke valve in the carburetor.

The CLOSED position enriches the fuel mixture for starting a cold engine.

The OPEN position provides the correct fuel mixture for operation after starting, and for restarting a warm engine.

CONTROLS AND FEATURES

Throttle Lever (SA type only)

The throttle lever controls engine speed.

An index mark on the engine cover shows throttle position and is helpful for setting the throttle correctly when starting (p. 24).

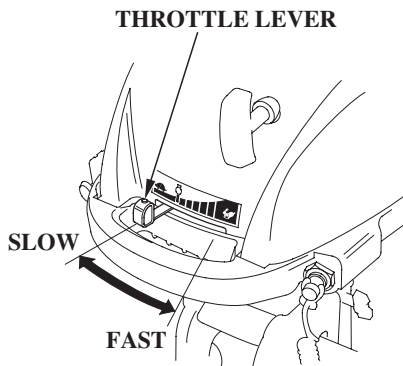

Throttle Grip (SHA/SCHA/LCHA type)

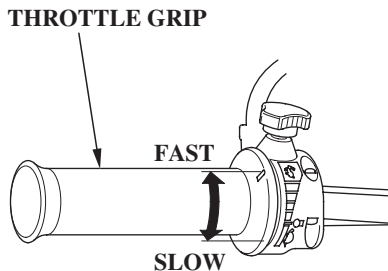

The throttle grip controls engine speed.

An index mark on the tiller arm shows throttle position and is helpful for setting the throttle correctly when starting (p. 24).

Throttle Friction Knob (SHA/SCHA/LCHA type)

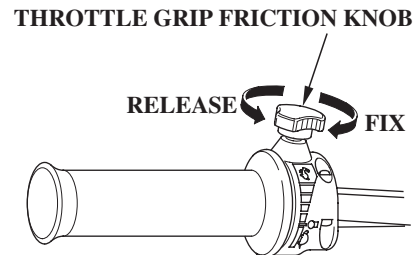

The throttle friction knob adjusts resistance to throttle grip rotation.

Turn the knob clockwise to increase friction for holding a throttle setting while cruising.

Turn the knob counterclockwise to decrease friction for easy throttle grip rotation.

Fuel Valve Lever

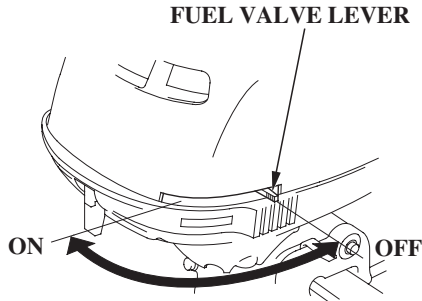

The fuel valve opens and closes the passage between the fuel tank and the carburetor.

The fuel valve lever must be in the ON position for the engine to run.

When the engine is not in use, leave the fuel valve lever in the OFF position to prevent carburetor flooding and to reduce the possibility of fuel leakage.

Recoil Starter Grip

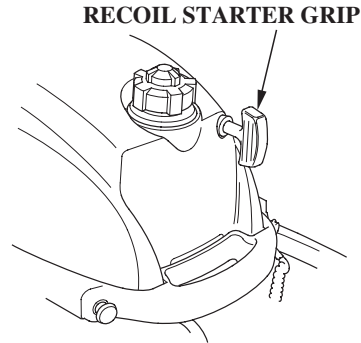

Pull the starter grip to operate the recoil starter for starting the engine.

Engine Cover Retaining Strap

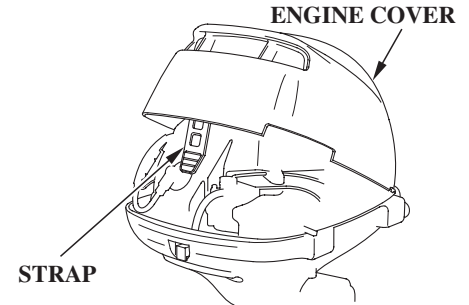

Use the retaining strap to hold the engine cover closed. Do not remove the engine cover while the engine is running.

CONTROLS AND FEATURES

Transom Angle Adjusting Bolt

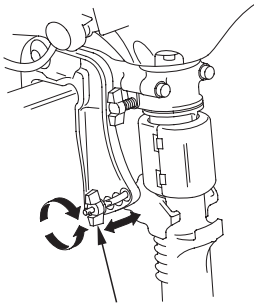

ADJUSTING BOLT AND WING NUT

The transom angle adjusting bolt is used to adjust the angle of the outboard motor in the normal operating position (see page 22).

Loosen the wing nut to free the adjusting bolt.

Adjust the angle of the outboard motor, and tighten the wing nut. Be sure that the bolt head and wing nut are seated in one of the four recesses in the adjustment slot.

Tilt Lever

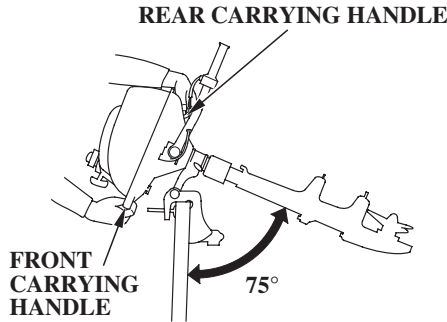

The tilt lever enables the outboard motor to be tilted for beaching, launching, or mooring.

Tilt the outboard motor by holding the carrying handles, as shown. The spring-loaded tilt lever will automatically move into position and hold the outboard motor when it reaches approximately 75°.

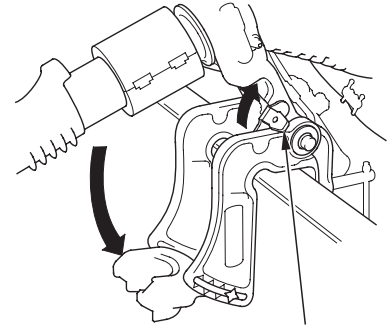

TILT LEVER

To return the outboard motor to the normal running position, hold the outboard motor and pull the tilt lever, then slowly lower the outboard motor.

Steering Friction Bolt

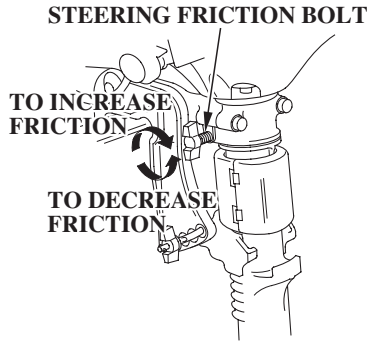

The steering friction bolt adjusts steering resistance.

Less friction allows the outboard motor to turn more easily. More friction helps to hold steady course while cruising or to prevent the outboard motor from swinging while trailering the boat.

Clamp Screws

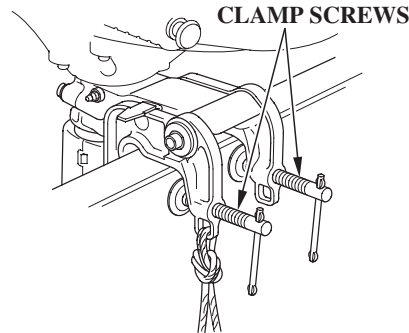

Use the clamp screws to secure the outboard motor to the transom.

Fuel Cap Vent Knob

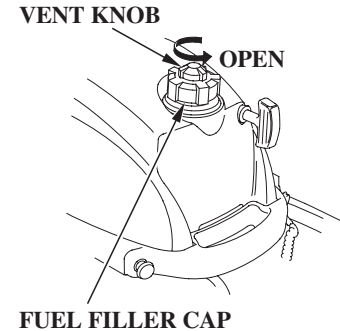

The cap is provided with a vent knob to seal the fuel tank. Open the vent knob 2 or 3 turns before starting the engine (p. 23).

CONTROLS AND FEATURES

OTHER FEATURES

Centrifugal Clutch (SCHA/LCHA type)

The centrifugal clutch automatically engages and transmits power when engine speed is increased above approximately 2,700 rpm. At idle speed, the clutch is disengaged.

Oil Level Inspection Window

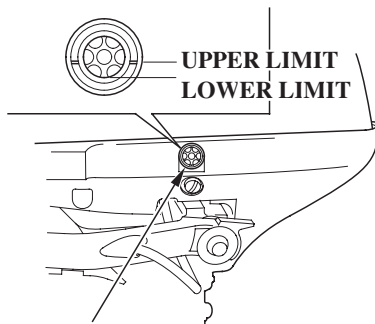

OIL LEVEL INSPECTION WINDOW

Use the oil level inspection window to check the engine oil level with the engine stopped and the outboard motor in the upright position.

Anode

Short shaft type

Long shaft type

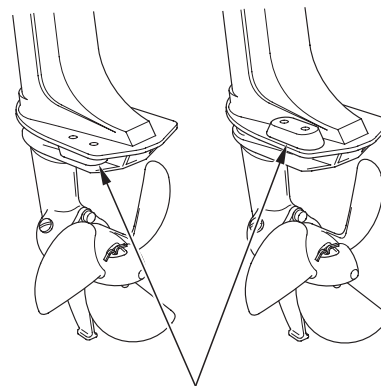

ANODE

The anode is made of a sacrificial material that helps to protect the outboard motor from corrosion.

INSTALLATION

Correct and secure installation is essential for safe boating and good performance. Follow the installation instructions provided in this manual.

POWER REQUIREMENTS

Before installation, check to be sure that the outboard motor does not exceed the recommended maximum horsepower for the boat on which it is to be installed. Refer to the boat's certification plate for recommended maximum horsepower. If the certification plate information is not available, contact the boat dealer or manufacturer.

For most applications, the outboard motor should have a horsepower rating which provides 80% of the maximum recommended horsepower for the boat.

INSTALLATION POSITION

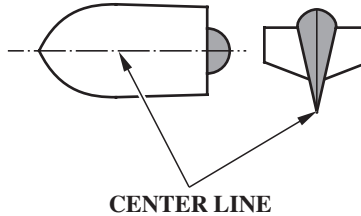

Install the outboard motor on the center of the boat transom.

The antiventilation plate of the outboard motor should be 0 – 2.0 inches below the bottom of the boat. With the boat in the water and loaded, the antiventilation plate should be about 5.9 inches below the surface of the water.

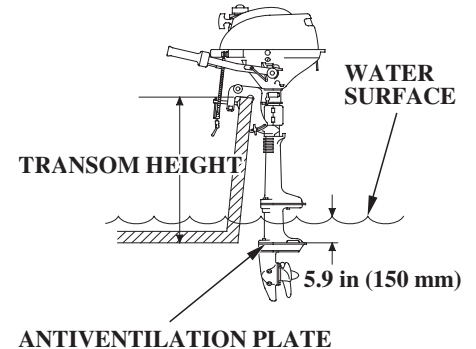

Type:	Transom Height
S:	16.5 in (418 mm)
L:	22.5 in (571 mm)

INSTALLATION

When the outboard motor is installed extremely low, water may enter into the engine under case and negatively affect the performance and durability. When installing, check that the outboard motor is high enough from the water level to keep the engine under case from waves, splash, etc. when the engine is stopped with the boat fully loaded.

Propeller ventilation will occur if the outboard motor is installed too high on the boat transom.

Optimum installation height varies with boat type and bottom shape. Contact the boat manufacturer for any special recommendations that are unique to a specific model of boat.

If the transom needs to be modified to accommodate the outboard motor, contact the boat manufacturer and follow their recommendations for corrective action.

ATTACHMENT

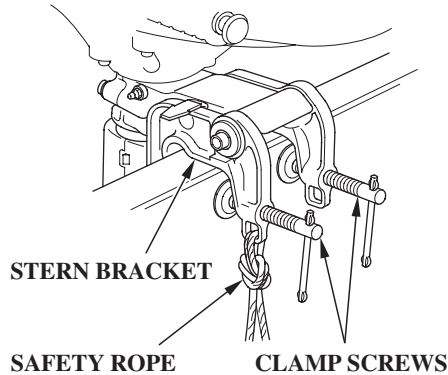

Attach the stern bracket to the boat transom by tightening the clamp screws.

Attach a rope from the boat to the hole in the stern bracket. This will help to prevent accidental loss of the outboard motor.

TRANSOM ANGLE ADJUSTMENT

Use the transom angle adjusting bolt (p. 22) to adjust the angle of the outboard motor so the propeller is perpendicular to the surface of the water.

BEFORE OPERATION

ARE YOU READY TO GET UNDER WAY?

Your safety is your responsibility. A little time spent in preparation will significantly reduce your risk of injury.

Knowledge

Read and understand this manual. Know what the controls do and how to operate them.

Familiarize yourself with the outboard motor and its operation before you get under way. Know what to do in case of emergencies.

Familiarize yourself with all laws and regulations relating to boating and the use of outboard motors.

Safety

Always wear a PFD (Personal Flotation Device) while on the boat.

Attach the emergency stop switch lanyard securely to your PFD or to your wrist.

IS YOUR OUTBOARD MOTOR READY TO GO?

For your safety, and to maximize the service life of your equipment, it is very important to take a few moments before you operate the outboard motor to check its condition. Be sure to take care of any problem you find, or have your authorized Honda marine dealer correct it, before you operate the outboard motor.

WARNING

Improperly maintaining this outboard motor, or failing to correct a problem before operation, can cause a malfunction in which you could be seriously hurt or killed.

Always perform a preoperation inspection before each operation, and correct any problem.

Safety Inspection

- Look around the outboard motor for signs of oil or gasoline leaks.
- Wipe up any spills before starting the engine.
- Check the stern bracket to be sure the outboard motor is securely installed.
- Check that all controls are operating properly.
- Replace any damaged parts.
- Check that all fasteners are in place and securely tightened.

Maintenance Inspection

- Check the engine oil level (p. 41). Running the engine with a low oil level can cause engine damage.
- Check to be sure the propeller is undamaged (p. 50).
- Check that the anode is securely attached to the antiventilation plate (p. 49) and is not excessively worn. The anode helps to protect the outboard motor from corrosion.
- Make sure the tool kit and emergency starter rope are onboard (p. 38). Replace any missing items.
- Check the fuel level in the fuel tank (p. 47).

OPERATION

SAFE OPERATING PRECAUTIONS

To safely realize the full potential of this outboard motor, you need a complete understanding of its operation and a certain amount of practice with its controls.

Before operating the outboard motor for the first time, please review the *IMPORTANT SAFETY INFORMATION* on page 6 and the chapter titled *BEFORE OPERATION*.

For your safety, avoid starting or operating the engine in an enclosed area. Your engine's exhaust contains poisonous carbon monoxide gas which can collect rapidly in an enclosed area and cause illness or death.

BREAK-IN PROCEDURE

Proper break-in procedure allows the moving parts to wear in smoothly for best performance and long service life.

For the first 10 hours, run the outboard motor at low speed, and avoid full-throttle operation.

TRANSOM ANGLE ADJUSTMENT

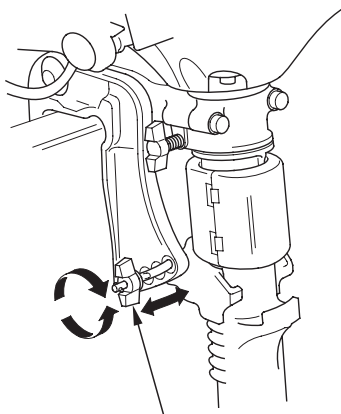

ADJUSTING BOLT AND WING NUT

The transom angle adjusting bolt is used to adjust the angle of the outboard motor in the normal operating position (p. 33).

To adjust, first tilt the outboard motor so it is not resting on the bolt.

There are four adjustment positions.

1. Loosen the wing nut to free the adjusting bolt.
2. Adjust the angle of the motor, and tighten the wing nut. Be sure that the bolt head and wing nut are seated in one of the four adjustment positions.

NOTICE

To prevent damage to the motor or boat, make sure the transom angle adjusting bolt is tight.

STARTING THE ENGINE

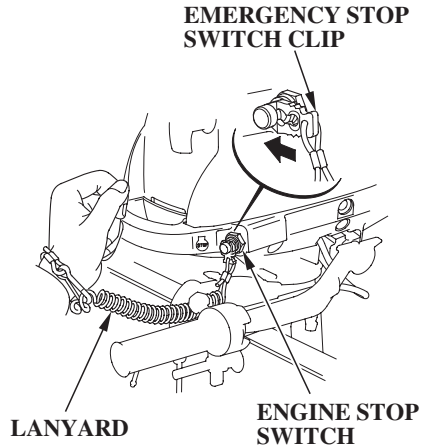

1. Put the emergency stop switch clip in the engine stop switch, and attach the lanyard to your PFD (Personal Flotation Device) or to your wrist, as shown.

The engine will not start or run, unless the clip is in the switch.

The emergency stop switch clip and lanyard system is a safety device that will stop the engine if you fall away from the controls while operating the boat.

Always attach the lanyard to your PFD, or to your wrist, before starting the engine.

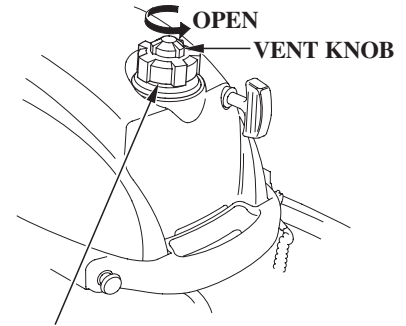

FUEL FILLER CAP

2. Open the fuel tank vent by turning the vent knob at least 2 or 3 turns counterclockwise.

OPERATION

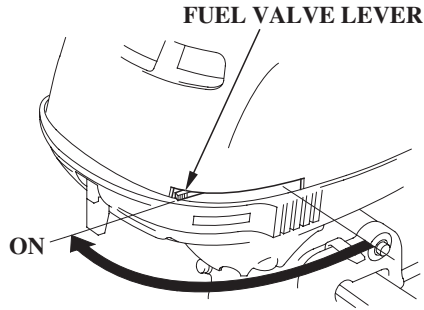

3. Move the fuel valve lever to the ON position.

THROTTLE LEVER type: SA

THROTTLE LEVER

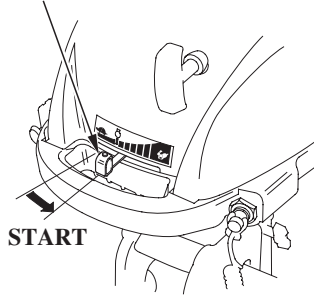

THROTTLE GRIP type: SHA, SCHA, LCHA

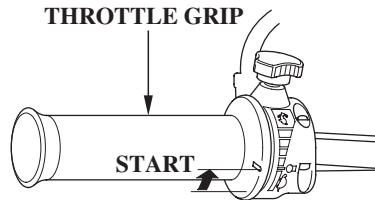

4. Move the throttle lever or the throttle grip to the START position.

Do not start the engine with the throttle lever or the throttle grip in the FAST position, or the boat will move suddenly when the engine starts.

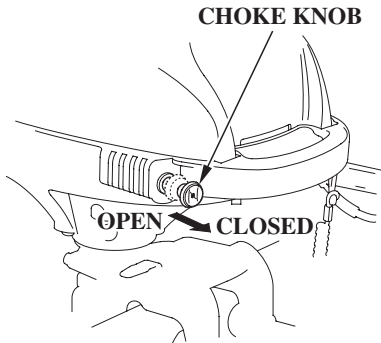

5. To start a cold engine, pull the choke knob to the **CLOSED** position. To restart a warm engine, leave the choke knob in the **OPEN** position.

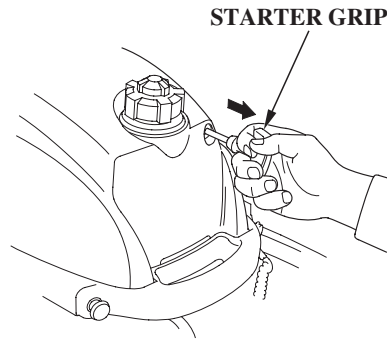

6. Pull the recoil starter grip slowly until you feel resistance, then pull briskly.

Return the starter grip gently.

7. If the choke knob was pulled to the **CLOSED** position to start the engine, gradually push it to the **OPEN** position as the engine warms up.

Also, as the engine warms up, the throttle lever or the throttle grip can be turned to the **SLOW** position without stalling.

8. Before getting under way, allow the engine to warm up sufficiently to ensure good performance.

OPERATION

EMERGENCY STARTING

If the recoil starter is not working properly, you can start the engine manually using the emergency starter rope supplied with the tool kit.

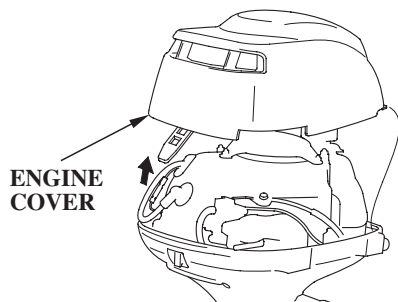

1. Remove the engine cover.

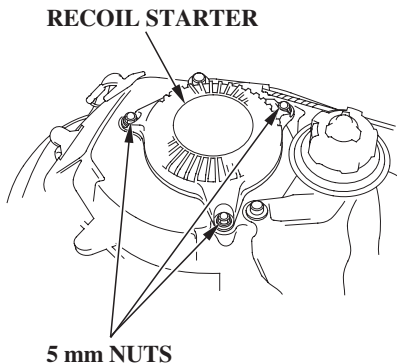

2. Remove the three 5 mm nuts with an 8 mm wrench and remove the recoil starter.
3. Set the controls the same as for normal starting (see pages 23 — 25). Use the choke control if needed.

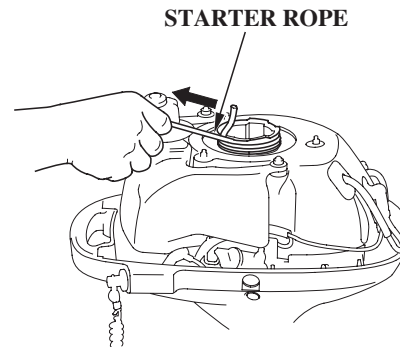

4. Set the knotted end of the emergency starter rope in the notch in the flywheel. Wind the rope clockwise around the flywheel, as shown.

5. Pull the emergency starter rope slowly until resistance is felt, then pull briskly.

Keep away from moving parts while pulling the rope.

If necessary, rewind the rope and pull again. If the engine does not start after several attempts, refer to *TAKING CARE OF UNEXPECTED PROBLEMS*, p. 56 .

6. If the choke was used to start the engine, return the knob to the normal operating position as the engine warms up.
7. Leave the recoil starter assembly off, but install the engine cover (p. 13).

WARNING

Exposed moving parts can cause injury.

- Do not operate the outboard motor without the engine cover.
- Use extreme care when installing the engine cover.

8. If it was necessary to remove the emergency stop switch lanyard from your wrist to perform the emergency starting procedure, be sure the lanyard is attached to your wrist before operating the outboard motor.
9. Have your closest authorized Honda marine dealer check your recoil starter system and correct the problem, so you can use the recoil starter.

The recoil starter assembly (p. 26) should be reinstalled after the recoil starter is working again. Install the recoil starter assembly with the engine stopped.

OPERATION

STOPPING THE ENGINE

Emergency Engine Stopping

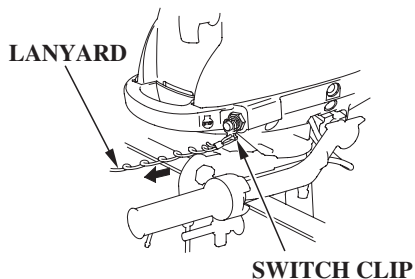

To stop the engine in an emergency, pull the clip out of the engine stop switch by pulling the lanyard.

We suggest that you stop the engine this way occasionally to verify that the engine or emergency stop switch is operating properly.

Normal Engine Stopping

THROTTLE LEVER type: SA

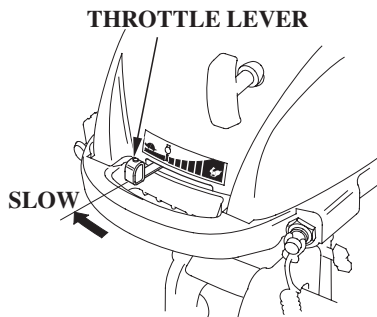

THROTTLE GRIP type: SHA, SCHA, LCHA

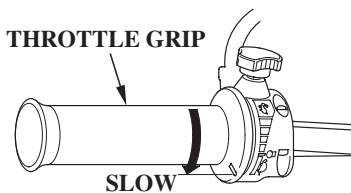

1. Move the throttle lever or the throttle grip to the SLOW position.

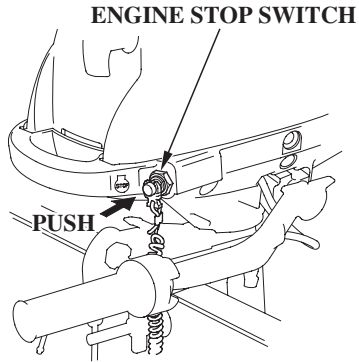

2. Push the engine stop switch button until the engine stops.

In the event that the engine does not stop when you push the engine stop switch, pull the emergency engine stop switch lanyard. If the engine continues to run, move the fuel valve lever to the OFF position and pull the choke knob to stop the engine.

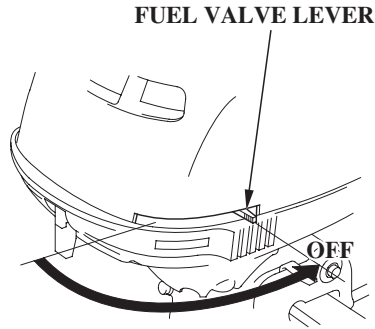

3. Move the fuel valve lever to the OFF position.

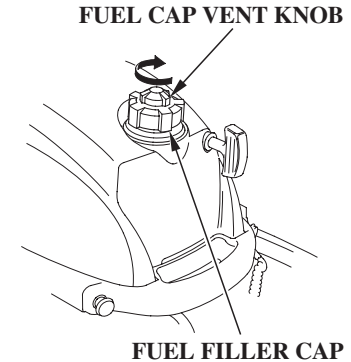

4. Close the fuel tank vent by turning vent knob clockwise.

OPERATION

THROTTLE OPERATION

THROTTLE LEVER type: SA

THROTTLE LEVER

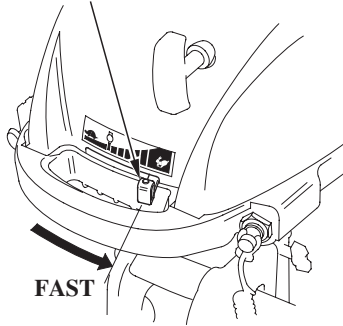

THROTTLE GRIP type: SHA, SCHA, LCHA

THROTTLE FRICTION KNOB

THROTTLE GRIP

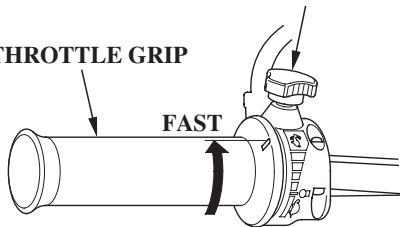

Use the throttle friction knob to help hold a constant throttle setting while cruising.

Turn the knob clockwise to increase throttle grip friction for holding a constant speed.

Turn the knob counterclockwise to decrease friction for easy grip rotation.

REVERSING THE OUTBOARD MOTOR

IMPORTANT SAFETY PRECAUTIONS

- *Before rotating the outboard motor (from either forward to reverse or from reverse to forward) reduce the engine speed to SLOW, or the boat could capsize.*
- *When operating in reverse, proceed with caution to avoid hitting any underwater obstructions with the propeller.*

THROTTLE LEVER type: SA

THROTTLE LEVER

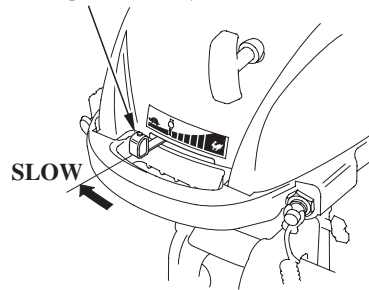

THROTTLE GRIP type: SHA, SCHA, LCHA

THROTTLE GRIP FRICTION KNOB

THROTTLE GRIP

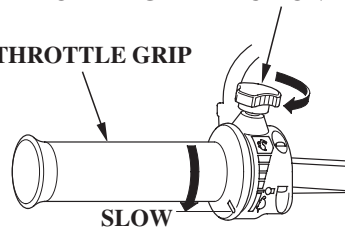

1. For the throttle lever type: Move the throttle lever to the SLOW position.

For the throttle grip type: Move the throttle grip to the SLOW position and hold it there by turning the throttle grip friction knob clockwise.

OPERATION

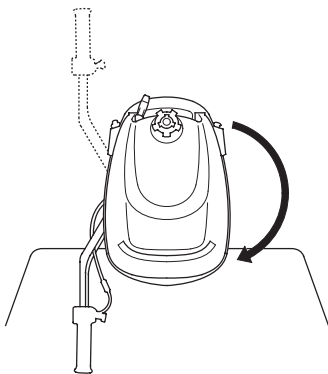

- To reverse direction, turn the outboard motor 180°, and then pivot the tiller handle as shown. For the throttle grip type, be careful not to hold and move the throttle grip when pivoting the tiller handle.

STEERING

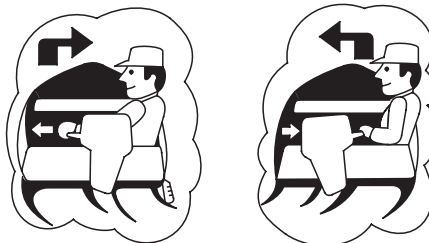

Steer by moving the tiller handle opposite the direction you want the boat to turn.

STEERING FRICTION BOLT

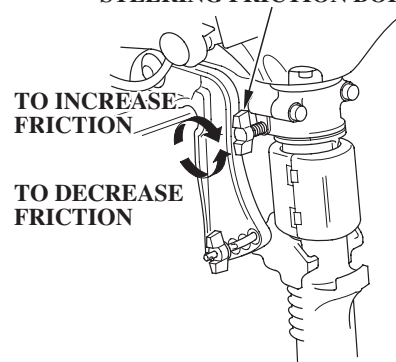

Use the steering friction bolt to help hold a steady course while cruising.

Turn the bolt clockwise to increase steering friction for holding a steady course.

Turn the bolt counterclockwise to decrease friction for easy turning.

CRUISING

Engine Speed

For best fuel economy, limit the throttle opening to 80%. Use the throttle friction control (p. 31) to help you hold a steady speed.

For rough water conditions or large waves, slow down to prevent the propeller from rising out of the water.

TRANSOM ANGLE

Install the outboard motor at the best transom angle for stable cruising and maximum power.

Transom angle too large: Incorrect causes boat to “squat”.

Transom angle too small: Incorrect causes boat to “bow steer”.

It is necessary to adjust the transom angle to compensate for changes in boat load, weight distribution, water conditions, or propeller selection.

Under normal running conditions, the boat will perform best when the antiventilation plate is level with the water.

When cruising into a high wind, lower the transom angle slightly to level the boat and improve stability. With a tail wind, raise the transom angle slightly.

NOTICE

Excessive transom angle during operation can cause propeller ventilation and overheating.

Transom Angle (Cruising)

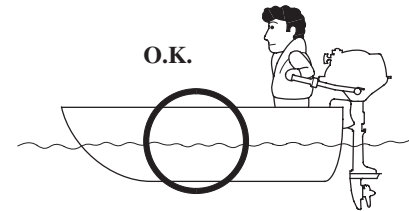

**CORRECT
GIVES MAXIMUM PERFORMANCE**

OPERATION

MOORING, BEACHING, LAUNCHING

To raise the outboard motor out of the water while the boat is moored, or for maximum clearance when beaching or launching, tilt the outboard motor to the 75° position.

Stop the engine before tilting the outboard motor. The 75° position is not an operating position.

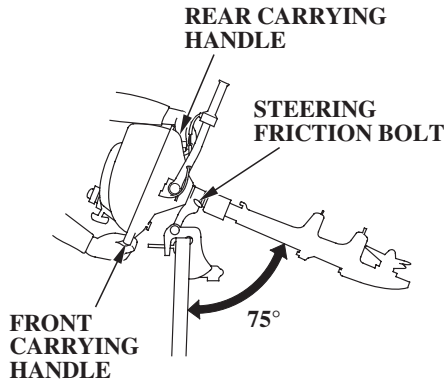

1. Stop the engine and turn the fuel valve lever off.
2. Close the fuel tank vent by turning the vent knob clockwise.
3. With the motor in the forward position, tilt the outboard motor using the front and rear carrying handles on the engine cover. The spring-loaded tilt lever will automatically move into position and hold the outboard motor when it reaches approximately 75°.
4. Adjust the steering friction bolt to keep the motor from moving.

NOTICE

- Do not use the tiller handle as a lever to raise the outboard motor. Applying excessive force to the tiller handle can damage it.
- If the motor is tilted in the reverse position, crankcase oil will enter the cylinder and may cause difficult starting or may prevent the engine from being cranked.

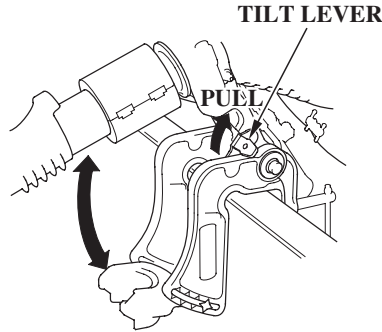

5. To return the outboard motor to the normal running position, hold the outboard motor by the front carrying handle on the engine case and pull the tilt level toward you, then lower the outboard motor slowly.

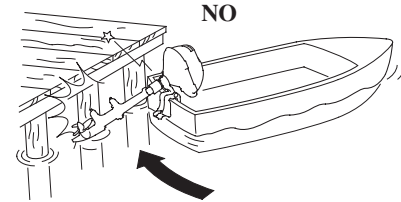

NOTICE

To avoid damaging the motor, be very careful when mooring a boat, especially when its motor is tilted up. Don't allow the motor to strike against the pier or other boats.

SERVICING YOUR OUTBOARD MOTOR

THE IMPORTANCE OF MAINTENANCE

Good maintenance is essential for safe, economical, and trouble-free operation. It will also help reduce air pollution.

WARNING

Improperly maintaining this outboard motor, or failure to correct a problem before operation, can cause a malfunction in which you could be seriously hurt or killed.

Always follow the inspection and maintenance recommendations and schedules in this owner's manual.

To help you properly care for your outboard motor, the following pages include a maintenance schedule, routine inspection procedures, and simple maintenance procedures using basic hand tools. Other service tasks that are more difficult, or require special tools, are best handled by professionals and are normally performed by a Honda technician or other qualified mechanic.

The maintenance schedule applies to normal operating conditions. If you operate your outboard motor under unusual conditions, consult an authorized Honda marine dealer for recommendations applicable to your individual needs and use.

Remember that your authorized Honda marine dealer knows your outboard motor best and is fully equipped to maintain and repair it.

To ensure the best quality and reliability, use only new, genuine Honda parts or their equivalents for repair and replacement.

Maintenance, replacement, or repair of the emission control devices and systems may be performed by any marine engine repair establishment or individual, using parts that are “certified” to EPA standards.

SERVICING YOUR OUTBOARD MOTOR

MAINTENANCE SAFETY

Some of the most important safety precautions follow. However, we cannot warn you of every conceivable hazard that can arise in performing maintenance. Only you can decide whether or not you should perform a given task.

WARNING

Failure to properly follow maintenance instructions and precautions can cause you to be seriously hurt or killed.

Always follow the procedures and precautions in the owner's manual.

Safety Precautions

- Make sure the engine is off before you begin any maintenance or repairs. This will eliminate several potential hazards:
 - **Carbon monoxide poisoning from engine exhaust.**
Be sure there is adequate ventilation whenever you operate the engine.
 - **Burns from hot parts.**
Let the engine and exhaust system cool before touching.
 - **Injury from moving parts.**
Do not run the engine unless instructed to do so.
- Read the instructions before you begin, and make sure you have the tools and skills required.
- To reduce the possibility of fire or explosion, be careful when working around gasoline. Use only a nonflammable solvent, not gasoline, to clean parts. Keep cigarettes, sparks, and flames away from all fuel-related parts.
- Wear gloves when handling the propeller to protect your hands from sharp edges.

SERVICING YOUR OUTBOARD MOTOR

TOOL KIT AND EMERGENCY STARTER ROPE



EMERGENCY STARTER ROPE

The following tools are supplied with the outboard motor for simple maintenance procedures and emergency repairs. An emergency starter rope is also supplied. Keep these items on the boat, so they will always be available if you need them.

If your tool kit needs replacement, it is not available as a kit and each item must be ordered individually.



8 × 10 mm WRENCH



**FLAT/PHILLIPS
SCREWDRIVER**



**EMERGENCY STOP
SWITCH CLIP**



SPARK PLUG WRENCH



PLIERS

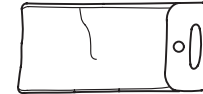

TOOL BAG

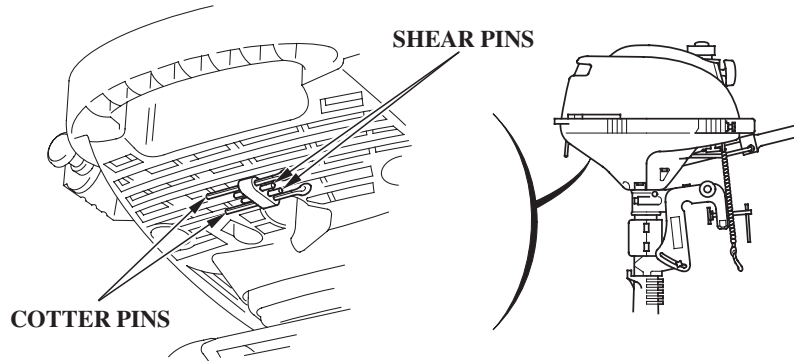

SERVICING YOUR OUTBOARD MOTOR

MAINTENANCE SCHEDULE

REGULAR SERVICE PERIOD (3) Perform at every indicated month or operating hour interval, whichever comes first.		Each use	First month or 10 hrs.	Every 6 months or 50 hrs.	Every year or 150 hrs.
ITEM					
Engine oil	Check level	<input type="radio"/>			
	Change		<input type="radio"/>	<input type="radio"/>	
Gear case oil	Change		<input type="radio"/>	<input type="radio"/>	
Starter rope	Check			<input type="radio"/>	
Carburetor linkage	Check-adjust		<input type="radio"/> (2)	<input type="radio"/> (2)	
Valve clearance	Check-adjust				<input type="radio"/> (2)
Spark plug	Check-adjust			<input type="radio"/>	
	Replace		Every 200 hrs.		
Propeller and Cotter pin	Check	<input type="radio"/>			
Anode	Check	<input type="radio"/>			
Idle speed	Check-adjust		<input type="radio"/> (2)	<input type="radio"/> (2)	
Clutch shoes and drum (With clutch type)	Replace				<input type="radio"/> (2)

- (1) Lubricate more frequently when used in salt water.
- (2) These items should be serviced by an authorized Honda marine dealer, unless you have the proper tools and are mechanically proficient. Refer to the Honda shop manual for service procedures.
- (3) For professional/commercial use, log hours of operation to determine proper maintenance intervals.

SERVICING YOUR OUTBOARD MOTOR

REGULAR SERVICE PERIOD (3) Perform at every indicated month or operating hour interval, whichever comes first.		Each use	First month or 10 hrs.	Every 6 months or 50 hrs.	Every year or 150 hrs.
ITEM					
Swivel case lining and bush	Replace		Every 3 years (2)		
Water sealing	Replace		Every 3 years (2)		
Fuel line	Check	<input type="radio"/>			
	Replace		Every 2 years (If necessary) (2)		
Bolts and nuts	Check-tightness		<input type="radio"/> (2)		<input type="radio"/> (2)
Lubrication	Grease		<input type="radio"/> (1)	<input type="radio"/> (1)	
Fuel tank and tank filter	Clean			<input type="radio"/> (2)	
Crankcase breather tube	Check				<input type="radio"/> (2)

- (1) Lubricate more frequently when used in salt water.
- (2) These items should be serviced by an authorized Honda marine dealer, unless you have the proper tools and are mechanically proficient. Refer to the Honda shop manual for service procedures.
- (3) For professional/commercial use, log hours of operation to determine proper maintenance intervals.

SERVICING YOUR OUTBOARD MOTOR

ENGINE COVER REMOVAL AND INSTALLATION

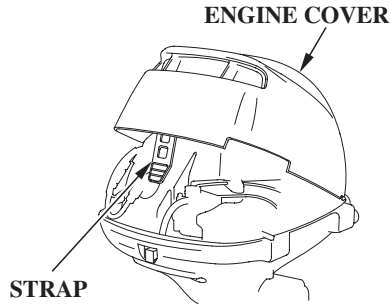

The engine cover retaining strap fastens the engine cover to the outboard motor.

To remove the engine cover, unhook the engine cover retaining strap, then lift the engine cover off the outboard motor.

To install the engine cover, place the cover on the outboard motor, then hook the engine cover retaining strap securely.

Engine Oil Level Check

Check the engine oil level with the engine stopped and the outboard motor in the vertical position.

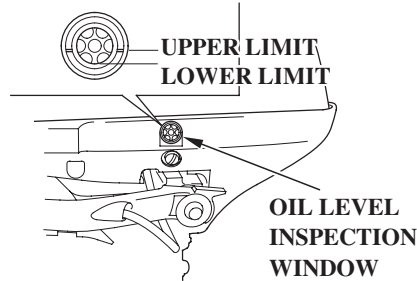

1. Check the oil level shown on the oil level inspection window.
2. If the oil level is near or below the lower limit mark on the window, fill with the recommended oil to the upper limit mark on the window.

NOTICE

Running the engine with a low oil level can cause engine damage.

Engine Oil Change

An engine oil evacuation device may be used to remove the engine oil.

Drain the used oil while the engine is warm. Warm oil drains quickly and completely.

SERVICING YOUR OUTBOARD MOTOR

1. Move the fuel valve lever to the OFF position, and turn the fuel cap vent knob clockwise to close the fuel vent.
2. Loosen the oil drain bolt, and turn the motor on its tiller handle side.
3. Remove the oil drain bolt and washer to drain the oil.

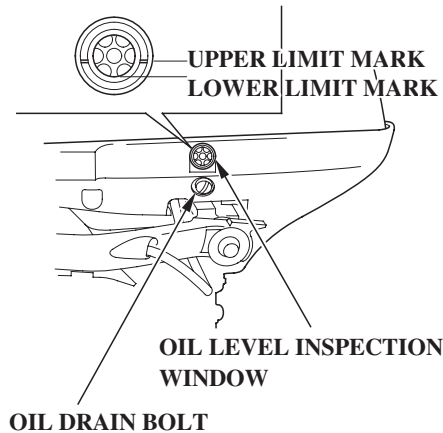

OIL FILLER CAP

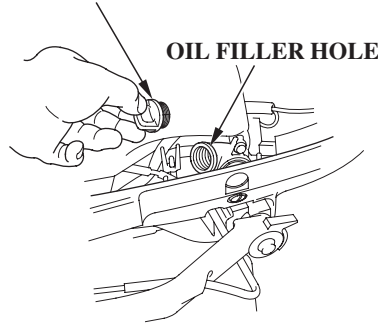

4. Stand the outboard motor in a vertical position, and install a new washer and the oil drain bolt securely.
5. Remove the engine cover.

NOTICE

Improper disposal of engine oil can be harmful to the environment. If you change your own oil, please dispose of the used oil properly. Put it in a sealed container, and take it to a recycling center. Do not discard it in a trash bin, dump it on the ground or pour it down a drain.

6. Remove the oil filler cap and fill the crankcase with the recommended oil (see page 43) up to the upper limit mark on the oil level inspection window.

Engine oil refill capacity:
0.26 US qt (0.25 l)

7. Install the oil filler cap and tighten it securely.
8. Install the engine cover.

SERVICING YOUR OUTBOARD MOTOR

Engine Oil Recommendations

Oil is a major factor affecting performance and service life. Use 4-stroke automotive detergent oil.

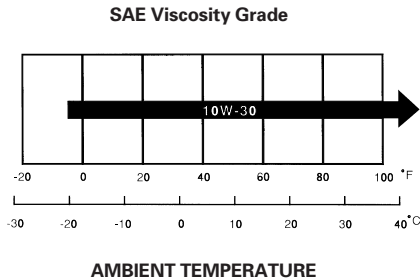

SAE 10W-30 is recommended for general use.

The SAE oil viscosity and service classification are in the API label on the oil container. Honda recommends that you use API SERVICE category SG, SH or SJ oil with the “starburst” certification mark displayed on the container.

SERVICING YOUR OUTBOARD MOTOR

Lubrication Points

Apply marine waterproof grease to the following parts:

Lubrication interval:

10 operating hours or a month after the date of purchase for initial, then every 50 operating hours or 6 months.

NOTICE

To prevent corrosion, apply anticorrosion oil to pivot surfaces where grease cannot penetrate.

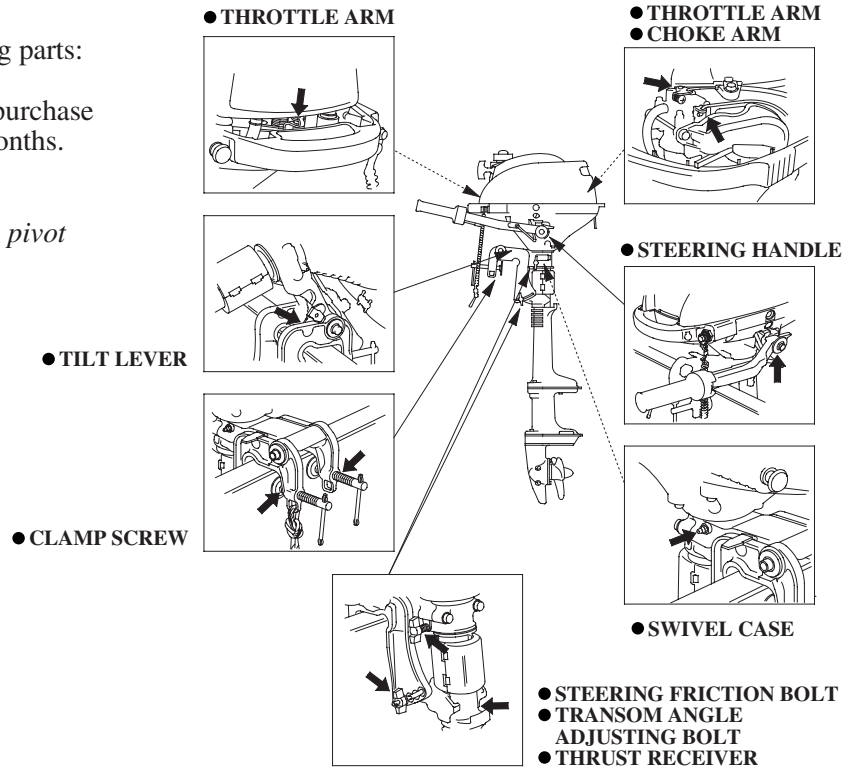

Apply Honda Marine Corrosion Inhibitor (or equivalent) to all areas under the engine cover and any exposed metal surfaces.

SERVICING YOUR OUTBOARD MOTOR

Spark Plug Service

RECOMMENDED SPARK PLUG:
CR4HSB (NGK)
U14FSR-UB (DENSO)

NOTICE

Incorrect spark plug can cause engine damage.

1. Remove the engine cover (p. 41).
2. Disconnect the spark plug cap from the spark plug.
3. Remove the spark plug with a spark plug wrench and screwdriver supplied in the tool kit.

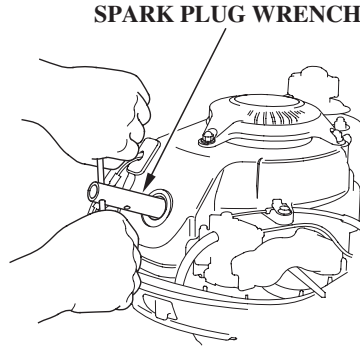

4. Inspect the spark plug. Replace it if the electrode is worn, or if the insulator is cracked or chipped.

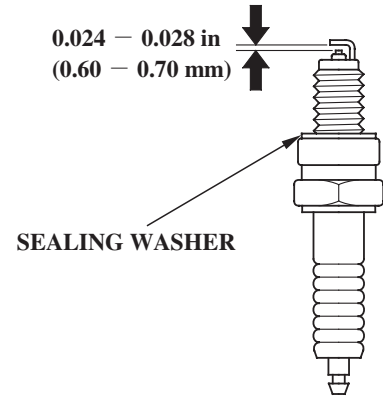

5. Measure the spark plug electrode gap with a suitable gauge. The gap should be 0.024 - 0.028 inches (0.60 - 0.70 mm). Correct the gap, if necessary, by carefully bending the side electrode.

SERVICING YOUR OUTBOARD MOTOR

6. Install the spark plug carefully, by hand, to avoid cross-threading.
7. After the spark plug seats, tighten with a spark plug wrench supplied in the tool kit to compress the sealing washer.

If reinstalling the used spark plug, tighten 1/8 - 1/4 turn after the spark plug seats.

If reinstalling a new spark plug, tighten 1/2 turn after the spark plugs seat.

NOTICE

A loose spark plug can overheat and damage the engine.

Overtightening the spark plug can damage the threads in the cylinder head.

8. Attach the spark plug cap.
9. Install the engine cover.

SERVICING YOUR OUTBOARD MOTOR

REFUELING

FUEL TANK CAPACITY:
0.26 US gal (1.0 ℓ)

With the engine stopped, turn the vent knob counterclockwise to open the fuel tank vent and remove the fuel filler cap.

Refill the fuel tank if the fuel level is low.

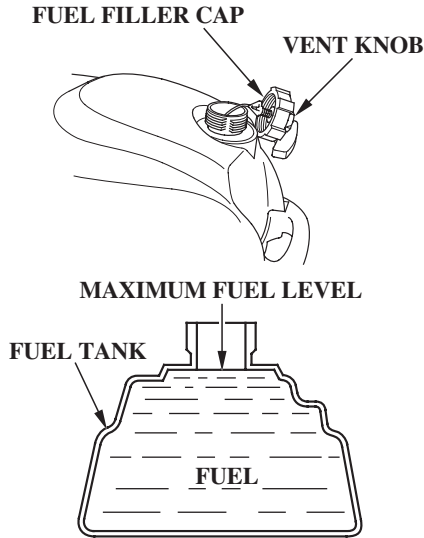

Refuel in a well-ventilated area. Fill the tank to the maximum fuel level.

After refueling, install the cap and tighten it securely. Turn the vent knob clockwise to close the fuel tank vent.

⚠ WARNING

Gasoline is highly flammable and explosive.

You can be burned or seriously injured when handling fuel.

- Stop the engine and keep heat, sparks, and flame away.
- Handle fuel only outdoors.
- Wipe up spills immediately.

Never refill the fuel tank inside a building where gasoline fumes may reach flames or sparks. Keep gasoline away from appliance pilot lights, barbecues, electric appliances, power tools, etc.

Spilled fuel is not only a fire hazard, it causes environmental damage. Wipe up spills immediately.

SERVICING YOUR OUTBOARD MOTOR

FUEL RECOMMENDATIONS

Use unleaded gasoline with a pump octane rating of 86 or higher.

This outboard motor is certified to operate on unleaded gasoline. Unleaded gasoline produces fewer engine and spark plug deposits and extends exhaust system life.

Never use stale or contaminated gasoline or an oil/gasoline mixture. Avoid getting dirt or water in the fuel tank.

Occasionally you may hear a light “spark knock” or “pinging” (metallic rapping noise) while operating under heavy loads. This is no cause for concern.

If spark knock or pinging occurs at a steady engine speed, under normal load, change brands of gasoline. If spark knock or pinging persists, see an authorized Honda marine dealer.

NOTICE

Running the engine with persistent spark knock or pinging can cause engine damage.

Running the engine with persistent spark knock or pinging is misuse, and the *Distributor's Limited Warranty* does not cover parts damaged by misuse.

SERVICING YOUR OUTBOARD MOTOR

Recoil Starter Rope Inspection

RECOIL STARTER ROPE

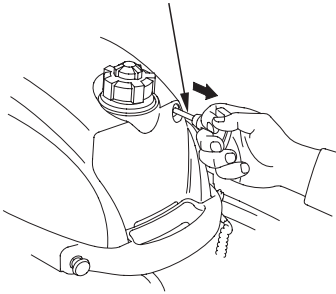

Inspect the recoil starter rope, and replace it if it becomes frayed.

Always keep the emergency starter rope on the boat in case the recoil starter rope fails.

Anode Replacement

Short shaft type

Long shaft type

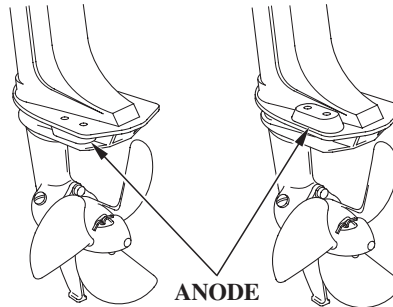

The anode is made of a sacrificial material that helps to protect the outboard motor from corrosion.

Replace the anode when it has been reduced to about half its original size, or if it is crumbling.

NOTICE

Painting or coating the anode will defeat its purpose and will lead to rust and corrosion damage to the outboard motor. The anode must be exposed to the water in order to protect the outboard motor.

SERVICING YOUR OUTBOARD MOTOR

Propeller Replacement

Before replacing the propeller, remove the clip from the engine stop switch to prevent any possibility of the engine being started while you are working with the propeller.

The propeller blades may have sharp edges, so wear heavy gloves to protect your hands.

Operating the outboard motor at higher altitudes will reduce available power. This may require decreasing the propeller pitch to maintain correct engine RPM.

Removal

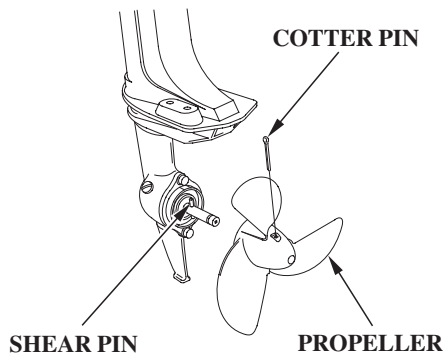

Remove the cotter pin, then remove the propeller and shear pin.

Installation

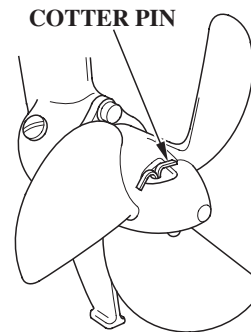

Install the propeller in the reverse order of removal.

NOTICE

Use a genuine Honda stainless steel cotter pin and bend the pin ends as shown. A non-stainless steel cotter pin can deteriorate if used in saltwater.

Spare shear pins and cotter pins are provided on the engine undercase (p. 38).

STORAGE

STORAGE PREPARATION

Proper storage preparation is essential for keeping your outboard motor troublefree and looking good. The following steps will help to keep rust and corrosion from impairing your outboard motor's function and appearance, and will make the engine easier to start when you use the outboard motor again.

Cleaning

Thoroughly clean and flush the outboard motor with fresh water after operation in dirty water or salt water.

Wash the outside of the outboard motor with clean, fresh water to remove mud, salt, seaweed, etc.

Touch up any damaged paint, and coat areas that may rust with Honda Corrosion Inhibitor, or equivalent. Lubricate controls with a silicone spray lubricant.

Fuel

Gasoline will oxidize and deteriorate in storage. Old gasoline will cause hard starting, and it leaves gum deposits that clog the fuel system. If the gasoline in your fuel tank and carburetor deteriorates during storage, you may need to have the carburetor and other fuel system components serviced or replaced.

The length of time that gasoline can be left in your fuel tank and carburetor without causing functional problems will vary with such factors as gasoline blend, your storage temperatures, and whether the fuel tank is partially or completely filled. The air in a partially filled fuel tank promotes fuel deterioration. Very warm storage temperatures accelerate fuel deterioration. Fuel deterioration problems may occur within a few months, or even less if the gasoline was not fresh when you filled the fuel tank.

The Distributor's Limited Warranty does not cover fuel system damage or engine performance problems resulting from neglected storage preparation.

You can extend fuel storage life by adding a gasoline stabilizer that is formulated for that purpose, or you can avoid fuel deterioration problems by draining all the fuel from the fuel tank and carburetor.

STORAGE

Adding a Fuel Stabilizer

When adding a fuel stabilizer, fill the fuel tank with fresh gasoline. If only partially filled, air in the tank will promote fuel deterioration during storage. If you keep a container of gasoline for refueling, be sure that it contains only fresh gasoline.

1. Add fuel stabilizer following the manufacturer's instructions.
2. Refer to previous page for proper running procedure. After adding a fuel stabilizer, run the engine outdoors for 10 minutes to be sure that the treated gasoline has replaced the untreated gasoline in the carburetor.

Starting the engine on land:
For safety, remove the propeller from the outboard motor (p. 50).

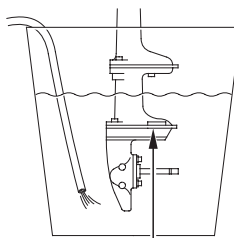

ANTIVENTILATION PLATE

- Place a container under the outboard motor, and fill it with clean, fresh water. The water level must be at least 6 inches above the antiventilation plate.

NOTICE

Running the engine without water can cause overheating and damage.

Damage caused by running the outboard motor without water is not covered by the *Distributor's Limited Warranty*.

3. Turn the engine OFF, turn the fuel valve lever OFF (p.13), and close the fuel cap vent knob (p.15).

Draining the Fuel Tank and Carburetor

You can avoid fuel deterioration problems by draining the fuel tank and carburetors.

1. With the outboard motor in a vertical position, place an approved gasoline container below the fuel drain outlet, and use a funnel to avoid spilling fuel.

⚠ WARNING

Gasoline is highly flammable and explosive. You can be burned or seriously injured when handling fuel.

- Stop the engine and keep heat, sparks, and flame away.
- Handle fuel only outdoors.
- Wipe up spills immediately.

2. With the engine stopped, turn the fuel cap vent knob counterclockwise to open the fuel vent and remove the fuel filler cap.
3. Loosen the carburetor drain screw and move the fuel valve lever to the ON position to drain the carburetor and the fuel tank into an approved gasoline container.

DRAIN SCREW

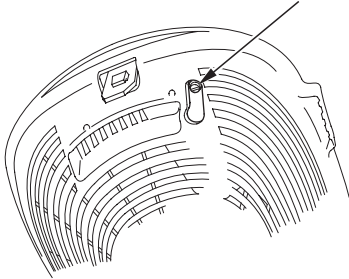

4. After draining is completed, tighten the carburetor drain screw and turn the fuel valve to the OFF position.
5. Turn the fuel filler cap vent knob clockwise to close the fuel vent.

Engine Oil

1. Change the engine oil (p. 41 – 42).
2. Remove the spark plug (p. 45), and remove the clip from the engine stop switch.
3. Pour a tablespoon (5 – 10 cm³) of clean engine oil into the cylinder.
4. Pull the starter rope several times to distribute the oil in the cylinder.
5. Reinstall the spark plug (p. 46).

STORAGE PRECAUTIONS

Select a well-ventilated storage area. If possible, avoid storage areas with high humidity.

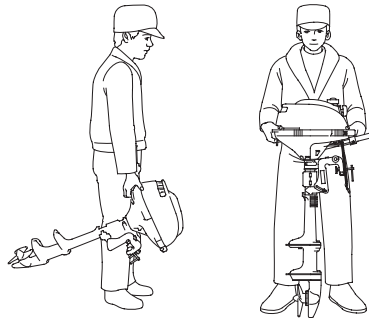

To carry the outboard motor, hold it by the carrying handle, as shown.

NOTICE

Lifting the outboard motor by the engine cover, or using the installed outboard motor as a handle or lever to move the boat, can damage the outboard motor.

If your fuel tank contains gasoline, store it away from any appliance that operates with a flame, such as a furnace, water heater, or clothes dryer. Also avoid any area with a spark-producing electric motor, or where power tools are operated.

Store the outboard motor either vertically or horizontally with the tiller handle side up.

STORAGE

CORRECT

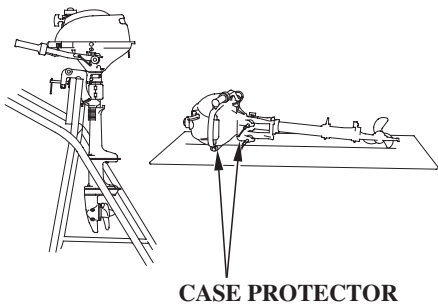

If storing horizontally, be sure to fold the tiller handle, and rest the outboard motor on its case protectors.

NOTICE

Any other horizontal storage position may cause damage or oil leakage.

INCORRECT

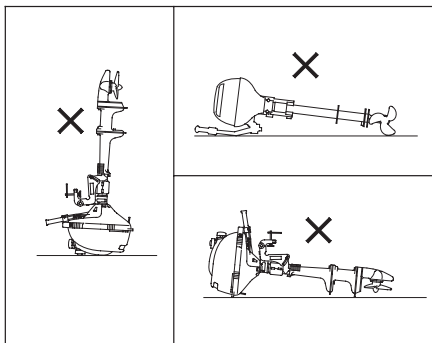

Cover the outboard motor to keep out dust. Do not use sheet plastic as a dust cover. A nonporous cover will trap moisture, promoting rust and corrosion.

REMOVAL FROM STORAGE

Check your outboard motor as described in the *BEFORE OPERATION* chapter of this manual.

If the cylinder was coated with oil during storage preparation, the engine may smoke briefly at startup. This is normal.

TRANSPORTING

WITH OUTBOARD MOTOR INSTALLED ON BOAT

When trailering a boat with the outboard motor attached, leave the engine in the normal running position, if possible, and tighten the steering friction bolt securely (p. 32).

If there is insufficient road clearance in the normal running position, then tilt the outboard motor and use a motor support bar, or remove the outboard motor from the boat. Refer to the manufacturer's instructions for using a motor support bar.



MOTOR SUPPORT BAR
(commercially available)

WITH OUTBOARD MOTOR REMOVED FROM BOAT

Remove the outboard motor from the boat and secure the outboard motor in either the vertical or horizontal position shown on p. 54.

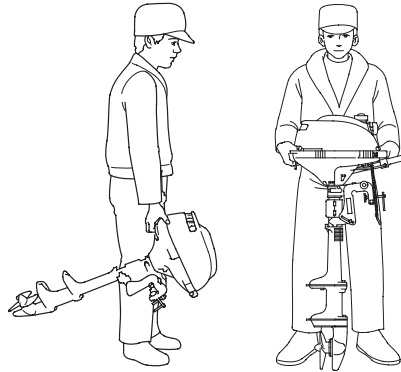

To carry, hold the outboard motor by the carrying handle, as shown.

NOTICE

Lifting the outboard motor by the engine cover, or using the installed outboard motor as a handle or lever to move the boat, can damage the outboard motor.

TAKING CARE OF UNEXPECTED PROBLEMS

ENGINE WILL NOT START	Possible Cause	Correction
1. Check emergency stop switch clip.	Clip not inserted in stop switch.	Insert clip in stop switch.
2. Check control positions.	Choke OPEN.	Pull choke knob to CLOSED position, unless engine is warm (p. 11).
	Throttle lever or grip not in START position.	Turn throttle lever or grip to START position (p. 24).

TAKING CARE OF UNEXPECTED PROBLEMS

ENGINE WILL NOT START (continued)	Possible Cause	Correction
3. Check fuel.	Out of fuel.	Refuel (p. 47).
	Fuel vent closed.	Open fuel tank vent (p. 15).
	Fuel valve lever in the OFF position.	Move the fuel valve lever to the ON position (p. 13).
	Bad fuel; boat stored without treating or draining gasoline, or refueled with bad gasoline.	Drain fuel tank and carburetors (p. 52). Refill with fresh gasoline (p. 47).
4. Remove and inspect spark plug.	Spark plug faulty, fouled or improperly gapped.	Gap or replace spark plug (p. 45).
	Spark plug wet with fuel (flooded engine).	Dry and reinstall spark plug. Start engine with choke and throttle open.
5. Take outboard motor to an authorized Honda marine dealer, or refer to the shop manual.	Carburetor malfunction, ignition malfunction, stuck valves, etc.	Replace or repair faulty components as necessary.

TAKING CARE OF UNEXPECTED PROBLEMS

HARD STARTING OR STALLS AFTER STARTING	Possible Cause	Correction
1. Check control positions.	Choke OPEN.	Pull choke knob to CLOSED position, unless engine is warm (p. 11).
	Throttle lever or grip not in START position.	Turn throttle lever or grip to START (p. 24).
2. Check fuel.	Fuel vent closed.	Open fuel tank vent (p. 15).
	Bad fuel; boat stored without treating or draining gasoline, or refueled with bad fuel.	Drain fuel tank and carburetor (p. 52). Refill with fresh gasoline (p. 47).
3. Remove and inspect spark plug.	Spark plug faulty, fouled or improperly gapped.	Gap or replace spark plug (p. 45).
4. Take outboard motor to an authorized Honda marine dealer, or refer to the shop manual.	Carburetor malfunction, ignition malfunction, etc.	Replace or repair faulty components as necessary.

TAKING CARE OF UNEXPECTED PROBLEMS

ENGINE WILL NOT DRIVE THE PROPELLER	Possible Cause	Correction
1. Check shear pin.	Broken shear pin.	Replace shear pin (p. 50).
2. Take outboard motor to an authorized Honda marine dealer, or refer to the shop manual.	Damaged clutch, drive train, or engagement mechanism.	Replace or repair faulty components as necessary.

TAKING CARE OF UNEXPECTED PROBLEMS

SUBMERGED MOTOR

A submerged outboard motor must be serviced immediately after it is recovered from the water in order to minimize corrosion.

If there is a Honda marine dealer nearby, take the motor to the dealer immediately. If you are far from a dealer, proceed as follows:

1. Remove the engine cover, and rinse the outboard motor with fresh water to remove salt water, sand, mud, etc.
2. Drain the carburetor as described on p. 52 .

3. Change the engine oil as described on p. 41 — 42 . If there was water in the engine crankcase, or if the used engine oil showed signs of water contamination, then a second engine oil change should be performed after running the engine for half an hour.

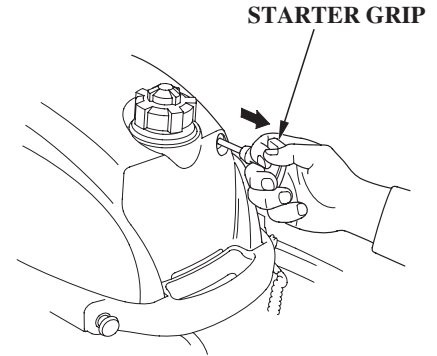

4. Remove the spark plug (p. 45), and remove the clip from the engine switch. Pull the recoil starter grip, rotate the flywheel a few revolutions to completely expel any water from the cylinder.

If the engine was running when it submerged, there may be mechanical damage, such as a bent connecting rod. If the engine binds when cranked, do not attempt to run the engine until it has been repaired.

TAKING CARE OF UNEXPECTED PROBLEMS

NOTICE

When cranking the engine with an open ignition circuit (spark plug removed from the ignition circuit), remove the clip from the engine stop switch to prevent possible damage to the ignition system.

5. Pour a teaspoon of engine oil into the spark plug hole, then pull the recoil starter grip several times to lubricate the inside of the cylinder.
6. Reinstall the spark plug, and put the emergency stop switch clip into the switch.

7. Attempt to start the engine.

If the engine fails to start, remove the spark plug, and dry it, then reinstall the spark plug and attempt to start the engine again.

If the engine starts, and no mechanical damage is evident, continue to run the engine for a half hour or longer.

8. As soon as possible, take the outboard motor to an authorized Honda marine dealer for inspection and service.

TECHNICAL AND CONSUMER INFORMATION

TECHNICAL INFORMATION

Serial Number Locations

Record the product identification number and engine serial number in the space provided on this page. You will need these numbers when ordering parts, and when making technical or warranty inquiries (p. 70).

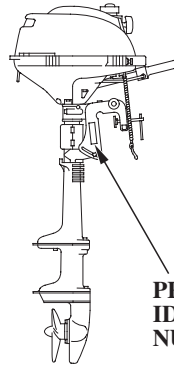

**PRODUCT
IDENTIFICATION
NUMBER**

The product identification number is stamped on a plate attached on side of the stern bracket.

Product identification number:

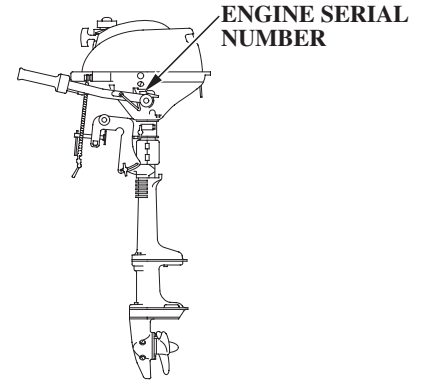

**ENGINE SERIAL
NUMBER**

The engine serial number is stamped on the engine.

Engine serial number:

Carburetor Modification for High Altitude Operation

At high altitude, the standard carburetor air-fuel mixture will be too rich. Performance will decrease, and fuel consumption will increase. A very rich mixture will also foul the spark plug and cause hard starting.

High altitude performance can be improved by specific modifications to the carburetor. If you always operate your outboard motor at altitudes above 5,000 feet (1,500 meters), have an authorized Honda marine dealer perform this carburetor modification.

Even with carburetor modification, engine horsepower will decrease about 3.5% for each 1,000-foot (300-meter) increase in altitude. The effect of altitude on horsepower will be greater than this if no carburetor modification is made.

NOTICE

When the carburetor has been modified for high altitude operation, the air-fuel mixture will be too lean for low altitude use. Operation at altitudes below 5,000 feet (1,500 meters) with modified carburetor may cause the engine to overheat and result in serious engine damage. For use at low altitudes, have an authorized Honda marine dealer return the carburetor to original factory specifications.

TECHNICAL AND CONSUMER INFORMATION

Oxygenated Fuels

Some conventional gasolines are being blended with alcohol or an ether compound. These gasolines are collectively referred to as oxygenated fuels. To meet clean air standards, some areas of the United States and Canada use oxygenated fuels to help reduce emissions.

If you use an oxygenated fuel, be sure it is unleaded and meets the minimum octane rating requirement.

Before using an oxygenated fuel, try to confirm the fuel's contents. Some states/provinces require this information to be posted on the pump.

The following are the EPA-approved percentages of oxygenates:

ETHANOL: ethyl or grain alcohol; 10% by volume.

You may use gasoline containing up to 10% ethanol by volume. Gasoline containing ethanol may be marketed under the name "Gasohol".

MTBE: Methyl Tertiary Butyl Ether; 15% by volume.

You may use gasoline containing up to 15% MTBE by volume.

METHANOL: methyl or wood alcohol; 5% by volume.

You may use gasoline containing up to 5% methanol by volume, as long as it also contains cosolvents and corrosion inhibitors to protect the fuel system. Gasoline containing more than 5% methanol by volume may cause starting and/or performance problems. It may also

damage metal, rubber, and plastic parts of your fuel system.

If you notice any undesirable operating symptoms, try another service station, or switch to another brand of gasoline.

Fuel system damage or performance problems resulting from the use of an oxygenated fuel containing more than the percentages of oxygenates mentioned above are not covered under warranty.

TECHNICAL AND CONSUMER INFORMATION

Emission Control System Information

Source of Emissions

The combustion process produces carbon monoxide, oxides of nitrogen, and hydrocarbons. Control of hydrocarbons and oxides of nitrogen is very important because, under certain conditions, they react to form photochemical smog when subjected to sunlight. Carbon monoxide does not react in the same way, but it is toxic.

Honda utilizes lean carburetor settings and other systems to reduce the emissions of carbon monoxide, oxides of nitrogen, and hydrocarbons.

The U.S. and California Clean Air Acts

EPA and California regulations require all manufacturers to furnish written instructions describing the operation and maintenance of emission control systems.

The following instructions and procedures must be followed in order to keep the emissions from your Honda engine within the emission standards.

Tampering and Altering

Tampering with or altering the emission control system may increase emissions beyond the legal limit. Among those acts that constitute tampering are:

- Removal or alteration of any part of the intake, fuel, or exhaust systems.
- Alterations that would cause the engine to operate outside its design parameters.

TECHNICAL AND CONSUMER INFORMATION

Problems That May Affect Emissions

If you are aware of any of the following symptoms, have your engine inspected and repaired by your servicing dealer.

- Hard starting or stalling after starting.
- Rough idle.
- Misfiring or backfiring under load.
- Afterburning (backfiring).
- Black exhaust smoke or high fuel consumption.

Replacement Parts

The emission control systems on your Honda engine were designed, built, and certified to conform with EPA and California emission regulations. We recommend the use of genuine Honda parts whenever you have maintenance done. These original-design replacement parts are manufactured to the same standards as the original parts, so you can be confident of their performance. The use of replacement parts that are not of the original design and quality may impair the effectiveness of your emission control system.

A manufacturer of an aftermarket part assumes the responsibility that the part will not adversely affect emission performance. The manufacturer or rebuilder of the part must certify that use of the part will not result in a failure of the engine to comply with emission regulations.

Maintenance

Follow the maintenance schedule on p. 39. Remember that this schedule is based on the assumption that your machine will be used for its designed purpose. Sustained high-load operation, or use in unusual conditions, will require more frequent service.

TECHNICAL AND CONSUMER INFORMATION

Star Label

A Star label was applied to this outboard motor in accordance with the requirements of the California Air Resources Board.

The Star Label means Cleaner Marine Engine

This engine has been certified as a:



The Symbol for Cleaner Marine Engines:

Cleaner Air and Water - for healthier lifestyle and environment.

Better Fuel Economy - burns up to 30 - 40 percent less gas and oil than conventional carbureted two-stroke engines, saving money and resources.

Longer Emission Warranty - protects consumer for worry free operation.

TECHNICAL AND CONSUMER INFORMATION



One Star Low Emission

The one-star label identifies engines that meet the Air Resources Board's Personal Watercraft and Outboard marine engine 2001 exhaust emission standards. Engines meeting these standards have 75% lower emissions than conventional carbureted two-stroke engines. These engines are equivalent to the U.S.EPA's 2006 standards for marine engines.



Two Stars Very Low Emission

The two-star label identifies engines that meet the Air Resources Board's Personal Watercraft and Outboard marine engine 2004 exhaust emission standards. Engines meeting these standards have 20% lower emissions than One Star-Low Emission engines.



Three Stars Ultra Low Emission

The three-star label identifies engines that meet the Air Resources Board's Personal Watercraft and Outboard marine engine 2008 exhaust emission standards or the Sterndrive and inboard marine engine 2003-2008 exhaust emission standards. Engines meeting these standards have 65% lower emissions than One Star-Low Emission engines.



Four Stars Super Ultra Low Emission

The four-star label identifies engines that meet the Air Resources Board's Sterndrive and Inboard marine engine 2009 exhaust emission standards. Personal Watercraft and Outboard marine engines may also comply with these standards. Engines meeting these standards have 90% lower emissions than One Star-Low Emission engines.

Cleaner Watercraft - Get the Facts
1-800-END-SMOG
www.arb.ca.gov

TECHNICAL AND CONSUMER INFORMATION

Specifications

MODEL	BF2D			
Description Code	BZBK		BZBF	
Type	SA	SHA	SCHA	LCHA
Overall length	16.1 in (410 mm)			
Overall width	11.0 in (280 mm)			
Overall height	37.2 in (945 mm)		43.3 in (1,100 mm)	
Transom height	16.5 in (418 mm)		22.5 in (571 mm)	
Weight	26.7 lbs (12.1 kg)	27.3 lbs (12.4 kg)	28.0 lbs (12.7 kg)	29.3 lbs (13.3 kg)
Rated power	1.5 kW (2.0 HP)			
Full throttle range	5,000–6,000 rpm			
Engine type	4 stroke OHV 1 cylinder			
Displacement	3.5 cu-in (57 cm ³)			
Spark plug gap	0.024–0.028 in (0.60–0.70 mm)			
Starter system	Recoil starter			
Ignition system	Transistorized Ignition Control Module (ICM)			
Lubrication system	Oil slinger system			
Specified oil	Engine: API standard (SG, SH or SJ) SAE 10W-30 Gear case: API standard (GL4/5) SAE 90 outboard motor gear oil			
Oil capacity	Engine: 0.26 US qt (0.25 ℓ) Gear case: 0.05 US qt (0.05 ℓ)			

CARB star label	ULTRA LOW EMISSION	
Cooling system	Engine: Forced air cooling	
Exhaust system	Underwater exhaust	
Spark plug	CR4HSB (NGK) U14FSR-UB (DENSO)	
Fuel	Automotive unleaded gasoline (86 pump octane or higher)	
Tank capacity	0.26 US gal (1.0 ℓ)	
Steering equipment	Tiller handle	
Steering angle	360°	
Transom angle	4 stages (5°, 10°, 15°, 20°)	
Tilt angle	75°	
Clutch system	—————	Centrifugal clutch

Tuneup

Spark plug gap	0.024–0.028 in (0.60–0.70 mm)	See page 45
Idle speed	2,000 ± 100 rpm	See shop manual
Valve clearance (cold)	Intake: 0.08 ± 0.02 mm Exhaust: 0.11 ± 0.02 mm	See shop manual
Other specifications	No other adjustment is needed	

Honda outboards are power rated in accordance with NMMA procedures and using the ICOMIA standard 28/23.

TECHNICAL AND CONSUMER INFORMATION

CONSUMER INFORMATION

Honda Publications

These publications will give you additional information for maintaining and repairing your outboard motor. You may order them from your Honda marine dealer.

Shop Manual

This manual covers complete maintenance and overhaul procedures. It is intended to be used by a skilled technician.

Parts Catalog

This manual provides complete, illustrated parts lists.

Customer Service Information

Honda Marine dealership personnel are trained professionals. They should be able to answer any question you may have. If you encounter a problem that your dealer does not solve to your satisfaction, please discuss it with the dealership's management. The Service Manager or General Manager can help. Almost all problems are solved in this way.

If you are dissatisfied with the decision made by the dealership's management, contact the Honda Marine Customer Relations Office. You can write:

American Honda Motor Co., Inc.
Marine Division
Customer Relations Office
4900 Marconi Drive
Alpharetta, Georgia 30005-8847

Or telephone: (770) 497-6400

When you write or call, please give us this information:

- Model and serial numbers (p. 62)
- Name of the dealer who sold the outboard motor to you
- Name and address of the dealer who services your outboard motor
- Date of purchase
- Your name, address, and telephone number
- A detailed description of the problem

TECHNICAL AND CONSUMER INFORMATION

Distributors Limited Warranty - 2005

This warranty is limited to Honda Outboard Motors distributed by American Honda Motor Co., Inc., Power Equipment Division, 4900 Marconi Drive, Alpharetta, Georgia 30005-8847.

PRODUCTS COVERED BY WARRANTY	LENGTH OF WARRANTY: (FROM DATE OF ORIGINAL PURCHASE)	
	NONCOMMERCIAL/ NONRENTAL	COMMERCIAL/ RENTAL
All Outboard Motors	36 Months	12 Months

TO QUALIFY FOR THIS WARRANTY:

The Honda Outboard Motor must be purchased from American Honda or a dealer authorized by American Honda to sell Honda Outboard Motors in the United States, Puerto Rico, or the U.S. Virgin Islands. This limited warranty applies to the first retail purchaser and each subsequent owner during the applicable warranty time period.

WHAT AMERICAN HONDA WILL REPAIR OR REPLACE UNDER WARRANTY:

American Honda will repair or replace, at its option, any part that is proven to be defective in material or workmanship under normal use during the applicable warranty time period. Warranty repairs and replacements will be made without charge for parts or labor. Anything replaced under warranty becomes the property of American Honda Motor Company, Inc. All parts replaced under warranty will be considered as part of the original product and any warranty on those parts will expire coincidentally with the original product warranty.

TO OBTAIN WARRANTY SERVICE:

You must take your Honda Outboard Motor and proof of the original purchase date, at your expense, to any dealer who is authorized to service Honda Outboard Motors in the United States, Puerto Rico, or the U.S. Virgin Islands, during the dealer's normal business hours. If you are unable to obtain warranty service, or are dissatisfied with the warranty service you receive, take the following steps: First, contact the owner of the dealership involved; normally this should resolve the problem. However, if you should require further assistance, write or call the Honda Marine Customer Relations. Please see *Customer Service Information* page 70.

EXCLUSIONS:

THIS WARRANTY DOES NOT EXTEND TO THE FOLLOWING:

- CONDITIONS CAUSED BY LACK OF ROUTINE MAINTENANCE
- PARTS AFFECTED OR DAMAGED BY AN ACCIDENT AND/OR COLLISION
- NORMAL WEAR
- FUEL CONTAMINATION AND WATER ENTERING ENGINE THROUGH THE FUEL INTAKE, AIR INTAKE OR EXHAUST SYSTEM
- USE IN AN APPLICATION FOR WHICH THE OUTBOARD MOTOR WAS NOT DESIGNED, SUCH AS RACING OR COMPETITIVE USE OR ANY OTHER MISUSE OR NEGLIGENCE
- INCORPORATION OF UNSUITABLE ATTACHMENTS OR PARTS
- THE UNAUTHORIZED ALTERATION, IMPROPER INSTALLATION, OR ANY CAUSES OTHER THAN DEFECTS IN MATERIAL OR WORKMANSHIP
- CORROSION TO STEERING SYSTEM OR ELECTRICAL COMPONENTS, CORROSION DUE TO ELECTROLYSIS, WATER BORN FOREIGN CHEMICALS, IMPROPER SERVICE OR CORROSION CAUSED BY DAMAGE OR ABUSE
- REIMBURSEMENT FOR TOWING CHARGES, IN AND OUT OF WATER CHARGES, OR TECHNICIAN TRAVEL TIME
- GROWTH OF MARINE ORGANISMS ON MOTOR SURFACES, EXTERNAL OR INTERNAL

DISCLAIMER OF CONSEQUENTIAL DAMAGE AND LIMITATION OF IMPLIED WARRANTIES:

AMERICAN HONDA DISCLAIMS ANY RESPONSIBILITY FOR LOSS OF TIME OR USE OF THE OUTBOARD, REVENUE, OR THE EQUIPMENT IN WHICH THE OUTBOARD IS INSTALLED, TRANSPORTATION, COMMERCIAL LOSS, OR ANY OTHER INCIDENTAL OR CONSEQUENTIAL DAMAGE. ANY IMPLIED WARRANTIES ARE LIMITED TO THE DURATION OF THIS WRITTEN LIMITED WARRANTY. Some states do not allow limitations on how long an implied warranty lasts and/or do not allow the exclusion or limitation of incidental or consequential damages, so the above exclusions and limitations may not apply to you. This warranty gives you specific legal rights, and you may also have other rights which vary from state to state.

TECHNICAL AND CONSUMER INFORMATION

ACCESSORIES AND REPLACEMENT PARTS

This warranty is limited to Honda Power Equipment parts, accessories and apparel when distributed by American Honda Motor Co., Inc., 1919 Torrance Blvd., Torrance, California 90501-2746.

PRODUCTS COVERED BY WARRANTY	LENGTH OF WARRANTY: (FROM DATE OF ORIGINAL PURCHASE)	
	NONCOMMERCIAL/ NONRENTAL	COMMERCIAL/ RENTAL
Accessories	12 Months	3 Months
Replacement Parts	6 Months	3 Months

TO QUALIFY FOR THIS WARRANTY:

1. The accessories or replacement parts must be purchased from American Honda, or a dealer, distributor or distributor's dealer authorized by American Honda to sell those products in the United States, Puerto Rico, and the U.S. Virgin Islands.
2. You must be the first retail purchaser. This warranty is not transferable to subsequent owners.

WHAT AMERICAN HONDA WILL REPAIR OR REPLACE UNDER WARRANTY:

American Honda will repair or replace, at its option, any marine product accessories or replacement parts that are proven to be defective in material or workmanship under normal use during the applicable warranty time period. Anything replaced under warranty becomes the property of American Honda Motor Company, Inc. All parts replaced under warranty will be considered as part of the original product and any warranty on those parts will expire coincidentally with the original product warranty. Accessories and replacement parts, installed by a dealer who is authorized by American Honda to sell them, will be repaired or replaced under warranty without charge for parts or labor. If installed by anyone else,

accessories and replacement parts will be repaired or replaced under warranty without charge for parts, but any labor charges will be the responsibility of the purchaser.

TO OBTAIN WARRANTY SERVICE:

You must take the Honda Outboard Motor product accessory or replacement part or the outboard motor or boat on which the accessory or replacement part is installed, and proof of purchase, at your expense, to any Honda Outboard Motor dealer in the United States, Puerto Rico, or the U.S. Virgin Islands who is authorized to sell that product, during the dealer's normal business hours.

If you are unable to obtain warranty service, or are dissatisfied with the warranty service you receive, take the following steps: First, contact the owner of the dealership or distributorship involved; normally this will resolve the problem. However, if you should require further assistance, write or call the Honda Marine Customer Relations Department of American. Please see *Customer Service Information* page 70.

THIS WARRANTY DOES NOT EXTEND TO ACCESSORIES OR PARTS AFFECTED OR DAMAGED BY ACCIDENT AND/OR COLLISION, NORMAL WEAR, USE IN AN APPLICATION FOR WHICH THE PRODUCT WAS NOT DESIGNED OR ANY OTHER MISUSE, NEGLIGENCE, INCORPORATION OR USE OF UNSUITABLE ATTACHMENTS OR PARTS, UNAUTHORIZED ALTERATION, IMPROPER INSTALLATION, OR ANY CAUSES OTHER THAN DEFECTS IN MATERIAL OR WORKMANSHIP OF THE PRODUCT.

DISCLAIMER OF CONSEQUENTIAL DAMAGE AND LIMITATION OF IMPLIED WARRANTIES:

AMERICAN HONDA DISCLAIMS ANY RESPONSIBILITY FOR LOSS OF TIME OR USE OF THE HONDA OUTBOARD MOTOR, OR THE BOAT ON WHICH THE PRODUCT IS INSTALLED, TRANSPORTATION, COMMERCIAL LOSS, OR ANY OTHER INCIDENTAL OR CONSEQUENTIAL DAMAGE. ANY IMPLIED WARRANTIES ARE LIMITED TO THE DURATION OF THIS WRITTEN WARRANTY. Some states do not allow limitations on how long an implied warranty lasts and/or do not allow the exclusion or limitation of incidental or consequential damages, so the above exclusions and limitations may not apply to you. This warranty gives you specific legal rights, and you may also have other rights which vary from state to state.

TECHNICAL AND CONSUMER INFORMATION

Emission Control System Warranty

Your new Honda outboard engine complies with both the U.S. EPA and State of California emission regulations. American Honda provides the same emission warranty coverage for outboard engines sold in all 50 states.

YOUR WARRANTY RIGHTS AND OBLIGATION

California

The California Air Resources Board and American Honda Motor Co., Inc. are pleased to explain the emission control system warranty on your 2001 and later Honda outboard engine. In California, new outboard engines must be designed, built and equipped to meet California's stringent anti-smog emission standards in addition to the U.S. EPA emissions standards.

Other States

In other areas of the United States your outboard engine must be designed, built and equipped to meet the U.S. EPA Emission Standard for spark ignited marine engines.

All States

American Honda Motor Co., Inc. must warranty the emission control system on your outboard engine for the period of time listed below provided there has been no abuse, neglect or improper maintenance of your outboard engine. Where a warranty condition exists, American Honda Motor Co., Inc. will repair your outboard engine at no cost to you including diagnosis, parts and labor. Your emission control system may include such parts as the carburetor or fuel injection system and catalytic converter. Also included may be hoses, connectors and other emission-related assemblies.

MANUFACTURER'S EMISSION CONTROL SYSTEM WARRANTY COVERAGE:

The 2001 and later outboard engines are warranted for four years or 250 hours of operation, whichever comes first. However, warranty coverage based on the hourly period is only permitted for outboard engines equipped with appropriate hour meters. If any emission-related part on your outboard engine is defective under warranty, the part will be repaired or replaced by American Honda Motor Co., Inc.

OWNER'S WARRANTY RESPONSIBILITY:

As the outboard engine owner, you are responsible for the performance of the required maintenance listed in your owner's manual. American Honda Motor Co., Inc. recommends that you retain all receipts covering maintenance on your outboard engine, but American Honda Motor Co., Inc. cannot deny warranty solely for the lack of receipts or for your failure to ensure the performance of all scheduled maintenance. As the outboard engine owner, you should, however, be aware that American Honda Motor Co., Inc. may deny you warranty coverage if your outboard engine or a part has failed due to abuse, neglect, improper maintenance, or unapproved modifications. You are responsible for presenting your outboard engine to a Honda Marine dealer as soon as a problem exists. The warranty repair should be completed in a reasonable amount of time, not to exceed 30 days. If you have any questions regarding your warranty rights and responsibilities, you should contact American Honda Motor Co., Inc., Marine Division Customer Relations Office. Please see *Customer Service Information* page 70.

WARRANTY COVERAGE:

Honda outboard engines manufactured after June 1, 2000 are covered by this warranty for a period of four years or 250 operating hours, whichever comes first, from the date of delivery to the retail purchaser. This warranty is transferred to each subsequent purchaser for the duration of the warranty period. Warranty repairs will be made without charge for diagnosis, parts and labor.

All defective parts replaced under this warranty become the property of American Honda Motor Co., Inc. A list of warranty parts is on the reverse side of this statement. Normal maintenance items, such as spark plugs and filters, that are on the warranted parts list are warranted up to their required replacement interval only. American Honda Motor Co., Inc. is also liable for damages to other engine components caused by a failure of any warranted part during the warranty period. Only Honda approved replacement parts will be used in the performance of any warranty repairs and they will be provided without charge to the owner. The use of replacement parts not equivalent to the original parts may impair the effectiveness of your engine's emission control system. If such a replacement part is used in the repair or maintenance of your engine, and an authorized Honda Marine dealer determines it is defective or causes a failure of a warranted part, your claim for your engine may be denied. If the part in question is not related to the reason that your engine requires repair, your claim will not be denied.

TECHNICAL AND CONSUMER INFORMATION

TO OBTAIN WARRANTY SERVICE:

You must take your Honda outboard engine, along with your sales registration card or other proof of original purchase date, at your expense, to any Honda Marine dealer who is authorized by American Honda Motor Co., Inc. to sell and service that Honda marine product during his normal business hours. Claims for repair or adjustment found to be caused solely by defects in material or workmanship will not be denied because the engine was not properly maintained and used. If you are unable to obtain warranty service, or are dissatisfied with the warranty service you received, contact the owner of the dealership involved. Normally this should resolve your problem. However, if you require further assistance, write or call the Honda Marine Customer Relations Office of American Honda Motor Co., Inc.

EXCLUSIONS:

FAILURES OTHER THAN THOSE RESULTING FROM DEFECTS IN MATERIAL OR WORKMANSHIP ARE NOT COVERED BY THIS WARRANTY. THIS WARRANTY DOES NOT EXTEND TO EMISSION CONTROL SYSTEMS OR PARTS WHICH ARE AFFECTED OR DAMAGED BY OWNER ABUSE, NEGLIGENCE, IMPROPER MAINTENANCE, MISUSE, MISFUELING, IMPROPER STORAGE, ACCIDENT AND/OR COLLISION. THE INCORPORATION OF, OR USE OF, UNSUITABLE ATTACHMENTS, OR THE UNAUTHORIZED ALTERATION OF ANY PART. THIS WARRANTY DOES NOT COVER REPLACEMENT OF EXPENDABLE MAINTENANCE ITEMS MADE IN CONNECTION WITH REQUIRED MAINTENANCE SERVICE AFTER THE ITEM'S FIRST SCHEDULED REPLACEMENT AS LISTED IN THE MAINTENANCE SECTION OF THE PRODUCT OWNER'S MANUAL, SUCH AS: SPARK PLUGS AND FILTERS.

DISCLAIMER OF CONSEQUENTIAL DAMAGE AND LIMITATION OF IMPLIED WARRANTIES:

American Honda Motor Co., Inc. disclaims any responsibility for incidental or consequential damages such as loss of time or the use of outboard engine, or any commercial loss due to the failure of the equipment; and any implied warranties are limited to the duration of this written warranty. This warranty is applicable only where the California or U.S. EPA emission control system warranty regulation is in effect.

EMISSION CONTROL SYSTEM WARRANTY PARTS:

SYSTEMS COVERED BY THIS WARRANTY:	PARTS DESCRIPTION
Fuel Metering	Carburetor assembly, Throttle body, Fuel injector, Fuel pump, Fuel pressure regulator, Throttle position sensor, Intake air temperature sensor, Engine temperature sensor, Manifold absolute pressure sensor, Idle air control valve, Barometric pressure sensor, Fuel line solenoid valve, Intake manifold, Intake valves, and Oxygen sensor or Air fuel ratio sensor
Air Induction	Air intake duct, Crankcase breather tube, Positive crankcase ventilation valve, Vapor separator, Intake manifold tuning valve (Intake air bypass control valve)
Ignition	Flywheel magneto, Ignition pulse generator, Ignition coil assembly, Ignition control module, Engine control module, Crankshaft position sensor, Spark plug cap, Spark plug*, Knock sensor, and Camshaft position sensor
Lubrication system	Oil pump and internal parts
Crankcase Emission Control	Oil filler cap
Exhaust	Exhaust manifold and Exhaust valves
VTEC System	VTEC valve
Miscellaneous Parts	Tubing, fittings, seals, gaskets, and clamps associated with these listed systems.
* Covered up to the first required replacement only. See the Maintenance Schedule in the owner's manual.	

WIRING DIAGRAM

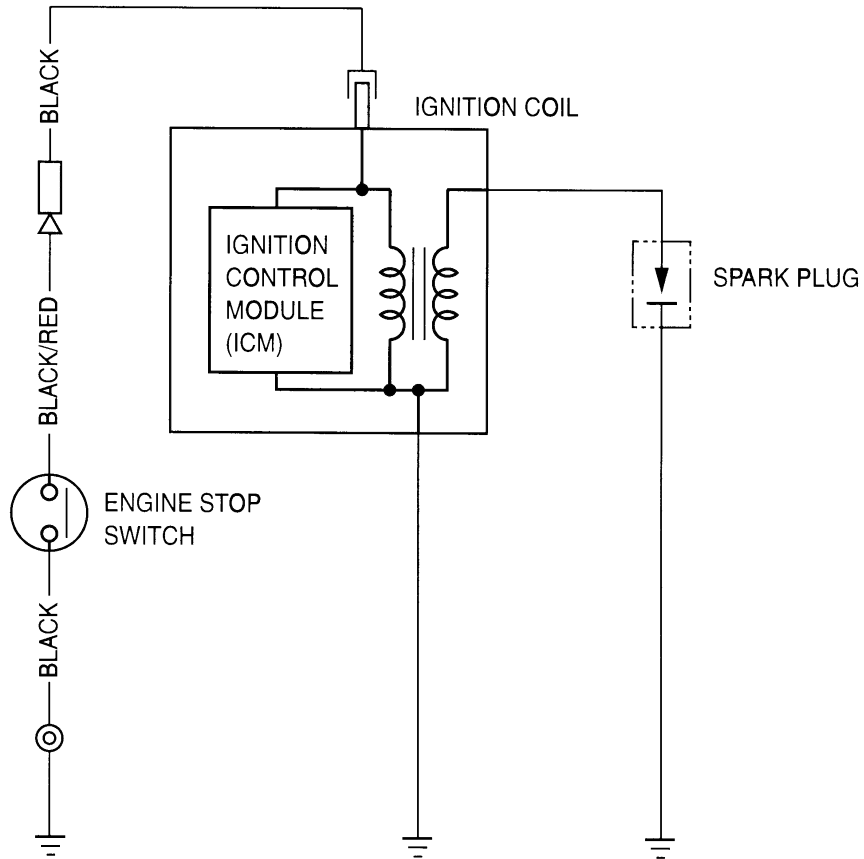

INDEX

Anode	16	EMERGENCY STARTING.....	26
Replacement.....	49	Emission Control System Information	65
ARE YOU READY TO GET UNDER WAY ?	20	Emission Control System Warranty.....	73
ATTACHMENT	18	Engine	
BEFORE OPERATION.....	20	Cover	
BREAK-IN PROCEDURE.....	22	REMOVAL AND INSTALLATION.....	41
Carburetor Modification for High Altitude		Retaining Strap.....	13
Operation	63	Oil	
Centrifugal Clutch (SCHA/LCHA type).....	16	Change.....	41
Choke Knob.....	11	Level Check	41
Clamp Screws.....	15	Level Inspection Window	16
COMPONENT AND CONTROL LOCATIONS	10	Recommendations	43
CONSUMER INFORMATION	70	Engine Stop Switch and Switch Clip.....	11
CONTROLS.....	11	ENGINE WILL NOT DRIVE THE PROPELLER.....	59
CONTROLS AND FEATURES	9	ENGINE WILL NOT START.....	56
CONTROLS AND FEATURE IDENTIFICATION		Fuel	
CODES.....	9	Cap Vent Knob.....	15
CRUISING	33	RECOMMENDATIONS.....	48
Customer Service Information.....	70	Valve Lever.....	13
Distributors Limited Warranty — 2005.....	71	HARD STARTING OR STALLS AFTER	
		STARTING	58

IMPORTANT SAFETY INFORMATION	6	SAFE OPERATING PRECAUTIONS	22
INDEX.....	76	SAFETY LABEL LOCATIONS	8
INSTALLATION.....	17	Serial Number Locations.....	62
INSTALLATION POSITION	17	SERVICING YOUR OUTBOARD MOTOR.....	36
IS YOUR OUTBOARD MOTOR		Spark Plug Service	45
READY TO GO ?	20	Specifications	69
Lubrication Points	44	Star Label	67
MAINTENANCE SAFETY	37	STARTING THE ENGINE	23
MAINTENANCE SCHEDULE	39	STEERING.....	32
MOORING, BEACHING, LAUNCHING.....	34	Steering Friction Bolt.....	15
OPERATION	22	STOPPING THE ENGINE	
OTHER FEATURES	16	Emergency Engine Stopping.....	28
OUTBOARD MOTOR SAFETY.....	6	Normal Engine Stopping.....	28
Oxygenated Fuels.....	64	STORAGE	51
POWER REQUIREMENTS.....	17	STORAGE PRECAUTIONS.....	53
Propeller Replacement	50	STORAGE PREPARATION.....	51
Recoil Starter Grip.....	13	Adding a Fuel Stabilizer.....	52
Recoil Starter Rope Inspection.....	49	Cleaning	51
REFUELING.....	47	Draining the Fuel Tank and Carburetor.....	52
REMOVAL FROM STORAGE	54	Engine oil	53
REVERSING THE OUTBOARD MOTOR	31	Fuel.....	51
		SUBMERGED MOTOR.....	60

INDEX

TAKING CARE OF UNEXPECTED PROBLEMS.....	56	WIRING DIAGRAM.....	75
TECHNICAL AND CONSUMER INFORMATION...	62		
TECHNICAL INFORMATION.....	62		
THE IMPORTANCE OF MAINTENANCE.....	36		
Throttle Friction Knob (SHA/SCHA/LCHA type)	12		
Throttle Grip (SHA/SCHA/LCHA type).....	12		
Throttle Lever (SA type only).....	12		
THROTTLE OPERATION	30		
Tilt Lever.....	14		
TOOL KIT AND EMERGENCY STARTER ROPE ...	38		
Transom Angle Adjusting Bolt.....	14		
TRANSOM ANGLE ADJUSTMENT	22		
TRANSPORTING	55		
WITH OUTBOARD MOTOR INSTALLED			
ON BOAT	55		
WITH OUTBOARD MOTOR REMOVED			
FROM BOAT	55		

MEMO

MEMO

HONDA

The power of dreams.™

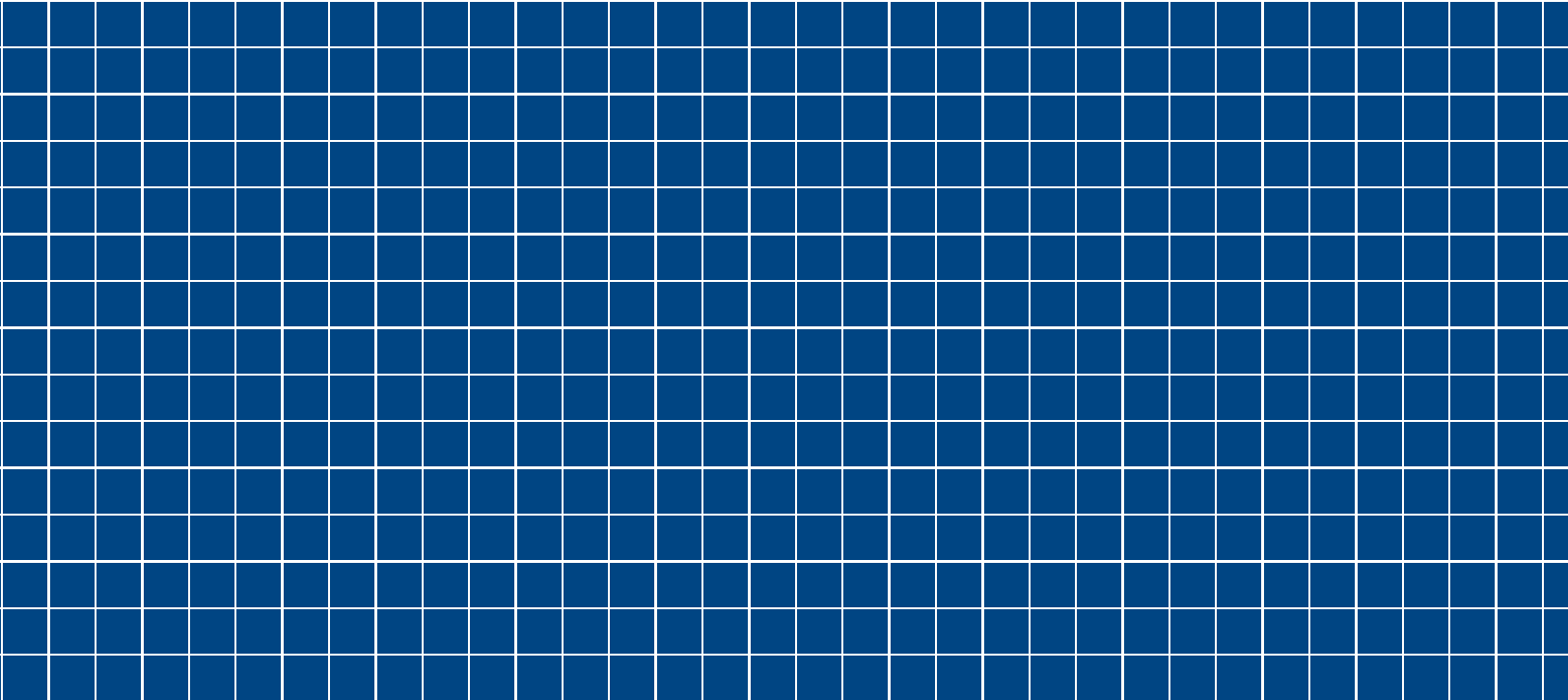

31ZW6608
00X31-ZW6-6080

EM3

AH

英

Y

HC

1000.2004.04

Printed in Japan