

**HONDA**

**Power**

**Equipment**

# Owner's Manual

## GXV340

### LPG Fueled Engine

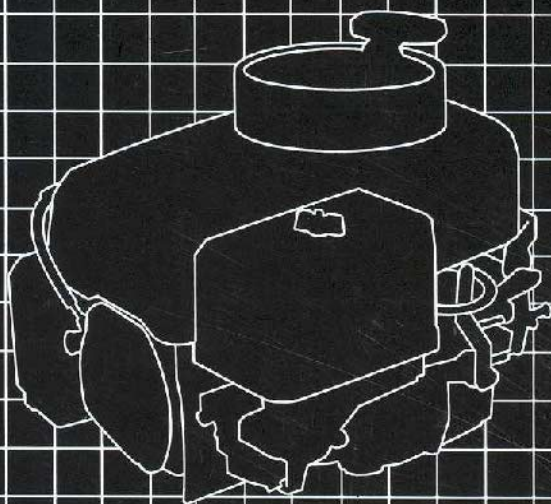



---

Thank you for purchasing a Honda engine.

This manual cover the operation and maintenance of LPG-fueled GXV340 engine. All information in this publication is based on the latest product information available at the time of printing.

The illustrations in this manual are based on the GXV340 DAP5 engine.

Honda Motor Co., Ltd. reserves the right to make changes at any time without notice and without incurring any obligation.

No part of this publication may be reproduced without written permission.

This manual should be considered a permanent part of the engine and should remain with the engine if it is resold.

It is illegal in some areas to operate an engine without a U.S.D.A. qualified spark arrester; check local laws and regulations. An optional spark arrester for this engine is available from any dealership displaying the Honda Power Equipment Engines sign.

Pay special attention to statements preceded by the following words:

**WARNING** Indicates a strong possibility of severe personal injury or death if instructions are not followed.

**CAUTION:** Indicates a possibility of personal injury or equipment damage if instructions are not followed.

**NOTE:** Gives helpful information.

If a problem should arise, or if you have any questions about your engine, consult an authorized Honda engine dealer.

**WARNING** Honda engines are designed to give safe and dependable service if operated according to instructions. Read and understand the Owner's Manual before operating the engine. Failure to do so could result in personal injury or equipment damage.

**CAUTION:**

- This engine is designed for use with LPG (liquefied petroleum gas) only.
- Use dry fuel lubricants only (See page 9).
- Do not use gasoline.

# CONTENTS

---

1. ENGINE SAFETY .....	3
2. COMPONENT IDENTIFICATION .....	4
3. BATTERY CONNECTIONS (for DC electric starter) .....	5
4. REMOTE CONTROL LINKAGE .....	6
5. PRE-OPERATION CHECK .....	7
6. STARTING THE ENGINE .....	10
7. OPERATION .....	12
8. STOPPING THE ENGINE .....	14
9. MAINTENANCE .....	15
10. TRANSPORTING/STORAGE .....	21
11. TROUBLESHOOTING .....	22
12. SPECIFICATIONS .....	23
13. WIRING DIAGRAM .....	24
14. WARRANTY SERVICE .....	25



To ensure safe operation —

- Carefully follow the installation and operation instructions of the LPG equipment manufacturer.
- To prevent fire hazards and to provide adequate ventilation, keep the engine at least 3 ft away from buildings and other equipment during operation.
- The muffler becomes very hot during operation and remains hot for a while after the engine stops. Be careful not to touch the muffler while it is hot.
- Do not place flammable objects such as fuel, matches, etc., close to the engine while it is running.
- Refuel in a well ventilated area with the engine stopped. Dry gas fuel is flammable and explosive under certain conditions.
- Do not smoke or allow flames or sparks where the engine is refueled or where fuel is stored.
- Do not overfill the fuel tank. Have the fuel tank pressure tested periodically.
- Check for leaks regularly. If leakage is detected, shut off the fuel supply at the source.
- Exhaust contains poisonous carbon monoxide gas. Avoid inhalation of exhaust gases. Never run the engine in a closed garage or confined area without proper ventilation.
- Do not place anything on the engine, as that may create a fire hazard.
- It is illegal in some areas to operate an engine without a spark arrester. Check local laws and regulations. An optional spark arrester for this product is available from your authorized Honda engine dealer.

## 2. COMPONENT IDENTIFICATION

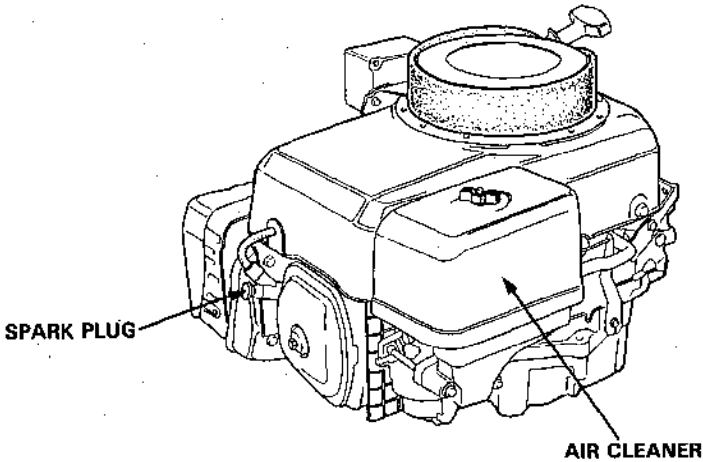
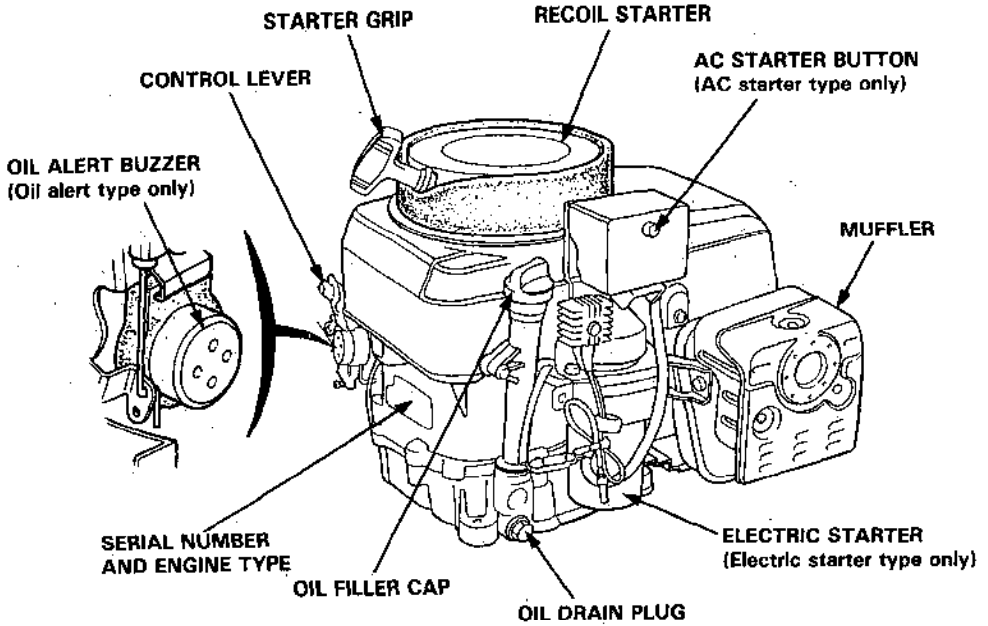

### 3. BATTERY CONNECTIONS (for DC electric starter)

Use a 12 volt battery with an ampere-hour rating of at least 18 AH.

Connect the battery positive (+) cable to the starter solenoid terminal as shown.

Connect the battery negative (-) cable to an engine mounting bolt, frame bolt, or other good engine ground connection.

Check the battery cable connections to be sure the cables are tightened and free of corrosion. Remove any corrosion and coat the terminals and cable ends with grease.

**WARNING** Batteries produce explosive gases. Keep sparks, flames, and cigarettes away. Always shield the eyes when working near batteries.

**CAUTION:** Be careful not to connect the battery in reverse polarity, as this will short circuit the battery charging system and trip the circuit breaker.

A regulator rectifier unit supplies charging current to the battery on DC starter-equipped engines.

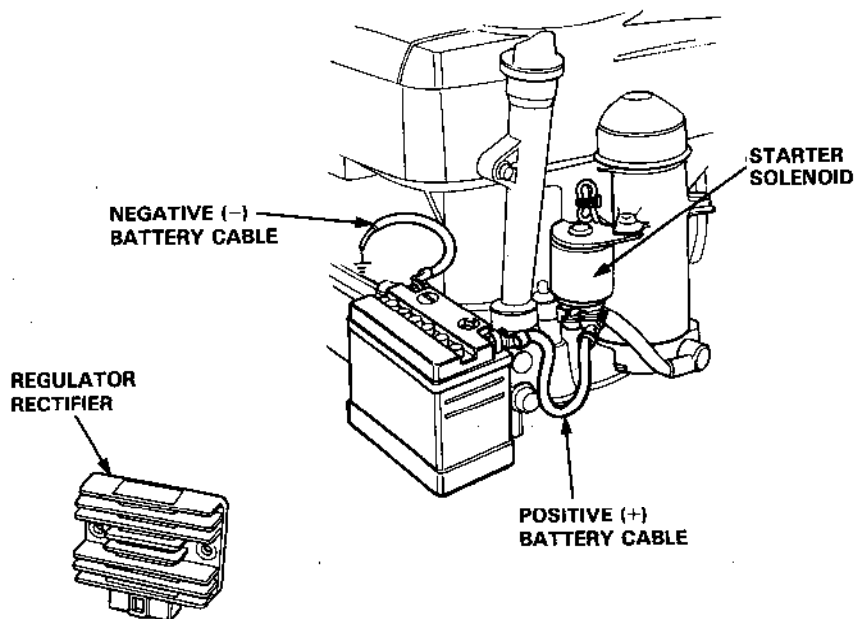

## 4. REMOTE CONTROL LINKAGE

---

The control lever is provided with a hole for cable attachment. Install a solid wire cable as shown below. Do not use braided wire cable.

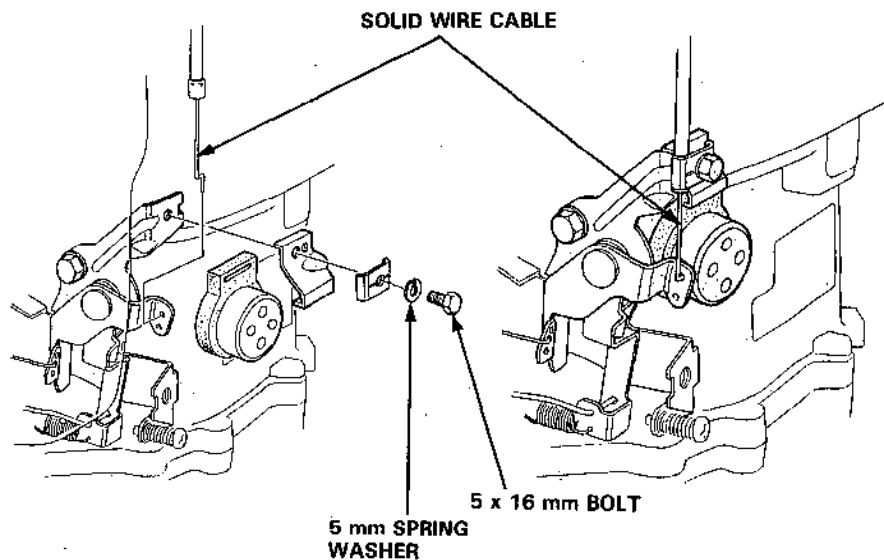



## 5. PRE-OPERATION CHECK

### 1. ENGINE OIL

**CAUTION:** Check oil level daily. Running the engine with insufficient oil can cause serious engine damage.

Check engine oil level with the engine stopped and standing on a level surface.

1. Remove the oil filler cap, and wipe the dipstick clean.
2. Insert the dipstick into the oil filler neck, but do not screw it in.
3. If the oil level is low, fill to the upper level with the recommended oil.

**OIL CAPACITY:** 1.1 ℓ (1.2 US qt, 1.0 Imp qt)

### RECOMMENDED ENGINE OIL

**CAUTION:** Engine oil is a major factor affecting engine performance and service life. Do not use multi-grade mineral-based oils. Use of multi-grade mineral-based oils may result in early engine wear and/or damage.

SAE 30, API service classification SF/CC, SF/CD or SF/CC, CD is recommended. The following are examples of oils that meet Honda's requirements for LPG-fueled engines:

- Pennzoil HD 30
- Valvoline HPO 30
- Castrol HD 30

**NOTE:** For engines that are run in temperatures below 0°C (32°F), Mobil 1 5W-30 Synthetic Oil may be used to ease starting. Do not use Mobil 1 5W-30 Synthetic Oil when the air temperature is above 0°C (32°F).

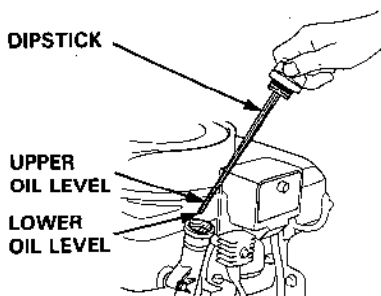

---

## 2. AIR CLEANER

**CAUTION:** Never run the engine without the air cleaner. Rapid engine wear will result from contaminants, such as dust and dirt, being drawn through the carburetor and into the engine.

Check the air cleaner elements to be sure they are clean and in good condition. Clean or replace the elements if necessary (page 17).

**NOTE:** Remember reinstall the air filter grommet, replace the grommet if necessary.

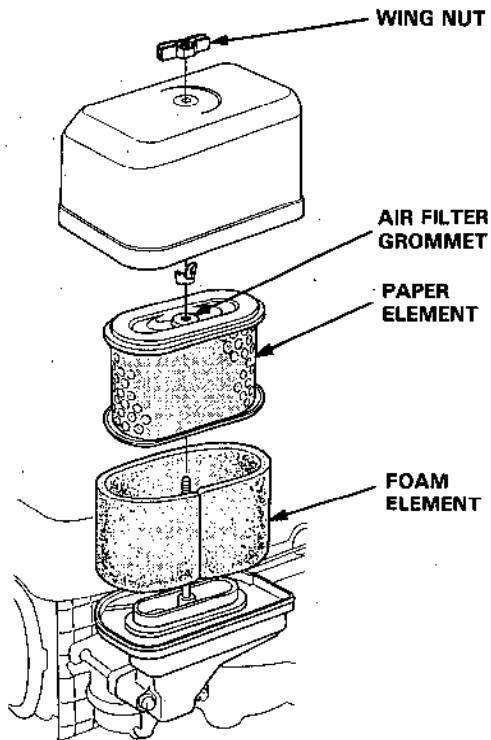

---

### 3. FUEL

Check that there is sufficient fuel in the fuel tank.

NOTE: This engine is designed for use with LPG only. Do not use gasoline.

 **WARNING**

- **LPG is extremely flammable and is explosive under certain conditions. Refuel in a well ventilated area with the engine stopped.**
- **Do not smoke or allow flames or sparks in the area where the engine is refueled or where fuel is stored.**
- **Do not overfill the fuel tank.**

## 6. STARTING THE ENGINE

---

1. Turn the fuel valve ON at the source.
2. Move the control lever to the START position.

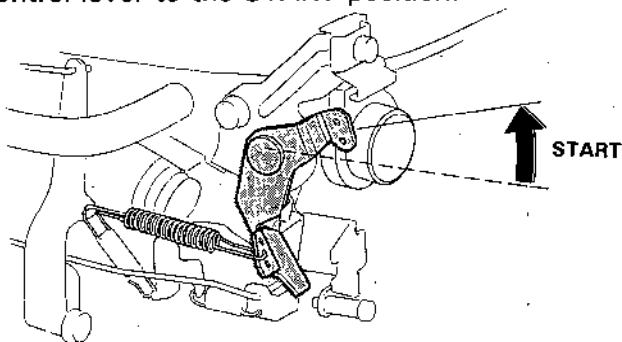

3. Start the engine following the directions that apply to the starter on your engine.

### • Recoil Starter

1. Pull the starter grip lightly until resistance is felt, then pull briskly.

**CAUTION:** Do not allow the starter grip to snap back against the engine. Return it gently to prevent damage to the starter.

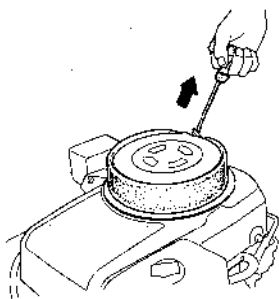

### • Electric Starter (DC or Battery Type)

1. Turn the engine switch to the START position and hold it there until the engine starts.

**CAUTION:** Do not use the electric starter for more than 5 seconds at a time. If the engine fails to start, release the switch and wait 10 seconds before operating the starter again.

When the engine starts, allow the engine switch to return to the ON position.

---

- **Electric Starter (AC or 120 volt Type)**

1. Connect your power cord to the switch box and the male end of the power cord to a properly grounded 120 Volt A/C outlet.

**CAUTION**  
USE ONLY WITH GROUND  
OUTLET AND 3-WIRE CORD.  
120 VOLT A.C. ONLY.  
DO NOT CRANK OVER 1  
MINUTE WITHOUT  
COOLING 15 MINUTES.  
DO NOT USE IN RAIN.

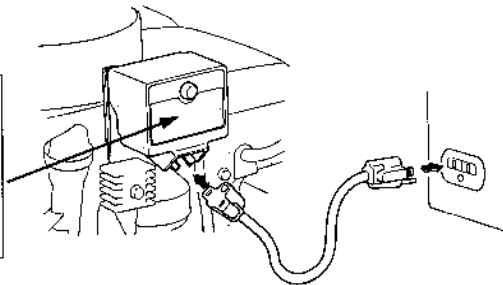

**WARNING**

- To minimize the possibility of potentially dangerous electrical shocks, always use a 3-conductor power cord with a power rating of no less than 13 amps. Also, be sure that the outlet you are using is properly grounded.
- Do not connect and disconnect the power cord with wet hands.
- Be sure to hold the plug when disconnecting the power cord from the electrical outlet or switch box.

2. Push the starter button until the engine starts.

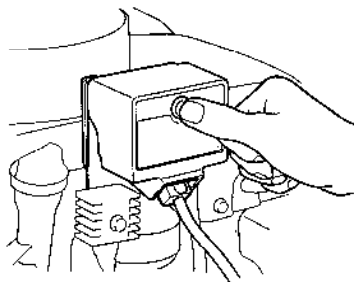

**CAUTION:**

- Do not operate the starter for more than 1 minute. If the engine fails to start, release the button and allow the starter to cool for 15 minutes before operating it again.
- To avoid serious engine damage, never operate the starter while the engine is running.
- After the engine starts, disconnect the power cord from the electrical outlet first, and then from the switch box.

## 7. OPERATION

---

When the engine warms up, move the control lever from the START position to the operating position for the desired engine speed.

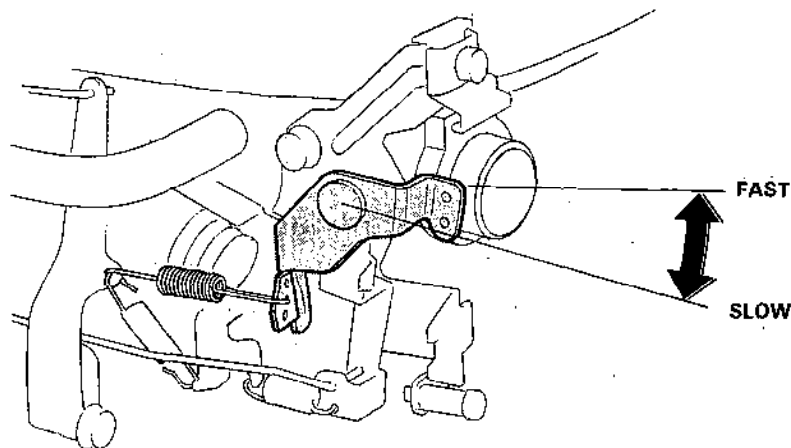

### **OIL ALERT BUZZER (oil alert type only)**

The "OIL ALERT" buzzer will warn you when the engine oil needs to be replenished. If the buzzer sounds, stop the engine and add oil (see page 7).

**CAUTION:** The buzzer indicates that oil should be added to prevent the oil level from falling below the safe limit. Running the engine with insufficient oil can cause serious engine damage.

---

- **High altitude operation**

At high altitude, the standard air-fuel mixture will be excessively rich. Performance will decrease, and fuel consumption will increase.

High altitude performance can be improved by adjusting the fuel mixture. If you always operate the engine at an altitude higher than 6000 feet above sea level, have an authorized Honda engine dealer adjust the fuel mixture for optimum performance at that altitude.

Even with suitable adjustment, engine horsepower will decrease approximately 3.5% for each 1,000 foot increase in altitude. The effect of altitude on horsepower will be greater than this if no carburetor modification is made.

**CAUTION:** Operation of the engine at an altitude lower than the air-fuel mixture is adjusted for may result in reduced performance, overheating, and serious engine damage caused by an excessively lean air/fuel mixture.

## 8. STOPPING THE ENGINE

---

1. Move the control lever to the STOP position.

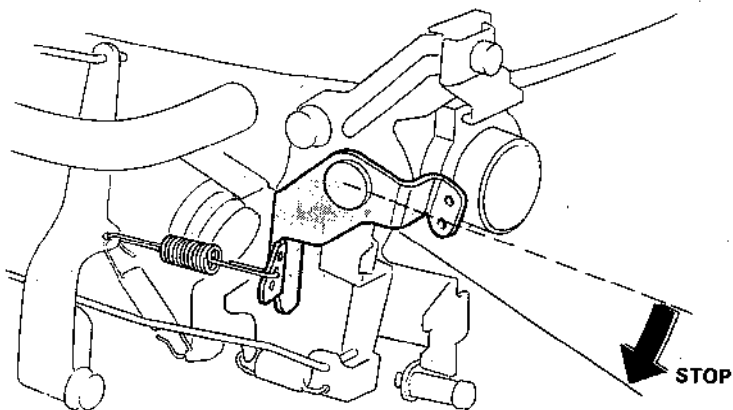

2. Turn the fuel valve OFF at the source.



## 9. MAINTENANCE

The purpose of the maintenance and adjustment schedule is to keep the engine in good operating condition. Inspect or service as scheduled in the table below.

**WARNING** Shut off the engine before performing any maintenance. If the engine must be run, make sure the area is well ventilated. The exhaust contains poisonous carbon monoxide gas.

**CAUTION:** Use only genuine HONDA parts or their equivalent. The use of replacement parts which are not of equivalent quality may damage the engine.

### Maintenance Schedule

REGULAR SERVICE PERIOD		Each use	First month or 20 Hrs.	Every 3 months or 50 Hrs.	Every 6 months or 100 Hrs.	Every year or 300 Hrs.
ITEM	Performed at every indicated month or operating hour interval, whichever comes first.					
Engine oil	Check level	○				
	Change		○	○		
Air cleaner	Check	○				
	Clean			○(1)		
Spark plug	Check-Clean				○	
Valve clearance	Check-Adjust					○(2)

NOTE: (1) Service more frequently when used in dusty areas.

(2) These items should be serviced by an authorized Honda dealer, unless the owner has the proper tools and is mechanically proficient. See the Honda Shop Manual.

## 1. Oil change

Drain the oil while the engine is still warm to assure rapid and complete draining.

1. Remove the oil filler cap and drain plug to drain the oil.
2. Install the drain plug and tighten it securely.
3. Refill with the recommended oil (see page 7) and check the oil level.
4. Install the oil filler cap.

**ENGINE OIL CAPACITY: 1.1 l (1.2 US qt, 1.0 Imp qt)**

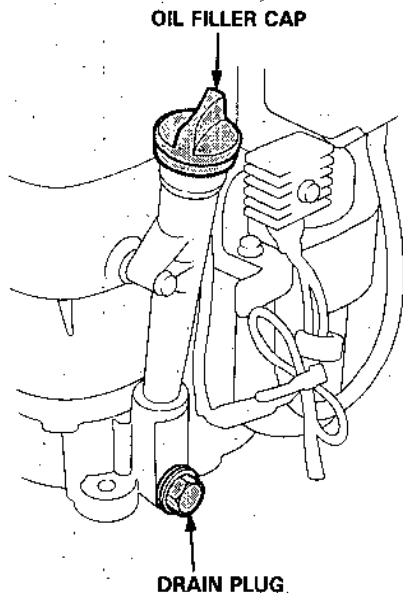

**CAUTION:** Used motor oil may cause skin cancer if repeatedly left in contact with the skin for prolonged periods. Although this is unlikely unless you handle used oil on a daily basis, it is still advisable to thoroughly wash your hands with soap and water as soon as possible after handling used oil.

**NOTE:** Please dispose of used motor oil in a manner that is compatible with the environment. We suggest you take it in a sealed container to your local service station for reclamation. Do not throw it in the trash or pour it on the ground.

## 2. Air cleaner service

A dirty air cleaner will restrict air flow to the carburetor. To prevent carburetor malfunction, service the air cleaner regularly. Service more frequently when operating the engine in extremely dusty areas.

**WARNING** Never use gasoline or low flash point solvents for cleaning the air cleaner element. A fire or explosion could result.

**CAUTION:** Never run the engine without the air cleaner. Rapid engine wear will result from contaminants such as dust and dirt being drawn through the carburetor, into the engine.

1. Remove the wing nuts and the air cleaner cover. Remove the elements and separate them. Carefully check both elements for holes or tears and replace if damaged.
2. Foam element: Wash the element in a solution of household detergent and warm water, then rinse thoroughly, or wash in nonflammable or high flash point solvent. Allow the element to dry thoroughly. Soak the element in clean engine oil and squeeze out the excess oil. The engine will smoke during initial start-up if too much oil is left in the foam.
3. Paper element: Tap the element lightly several times on a hard surface to remove excess dirt, or blow compressed air through the filter from the inside out. Never try to brush the dirt off; brushing will force dirt into the fibers. Replace the paper element if it is excessively dirty.

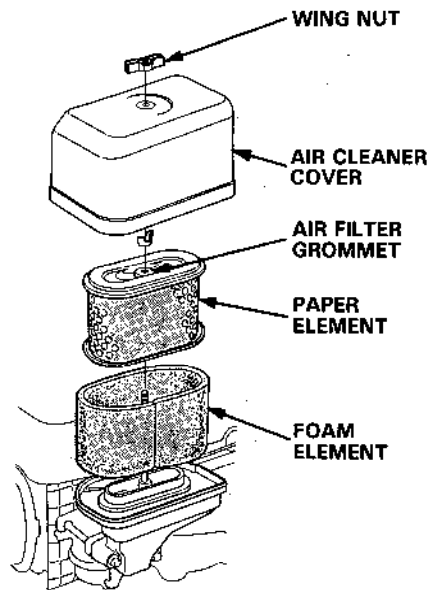

**NOTE:** Remember to reinstall the air filter grommet, replace the grommet if necessary.

### 3. Spark plug service

**Recommended spark plug: BPR5ES (NGK)  
W16EPR-U (ND)**

**CAUTION:** Use only the recommended spark plugs or equivalent. Spark plugs which have an improper heat range may cause engine damage.

To ensure proper engine operation, the spark plug must be properly gapped and free of deposits.

1. Remove the spark plug cap and use a spark plug wrench to remove the plug.

**WARNING** If the engine has been running, the muffler will be very hot. Be careful not to touch the muffler.

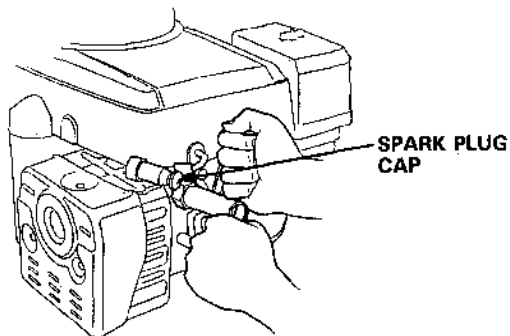

2. Visually inspect the spark plug. Discard it if the insulator is cracked or chipped. Clean the spark plug with a wire brush if it is to be reused.

3. Measure the plug gap with a feeler gauge. The gap should be 0.7–0.8 mm (0.028–0.031 in). Correct as necessary by bending the side electrode.

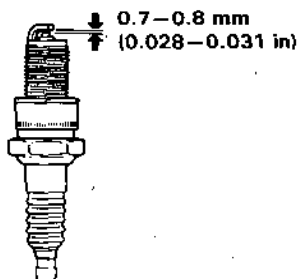

- 
4. Check that the spark plug washer is in good condition and thread the spark plug in by hand to prevent cross-threading.

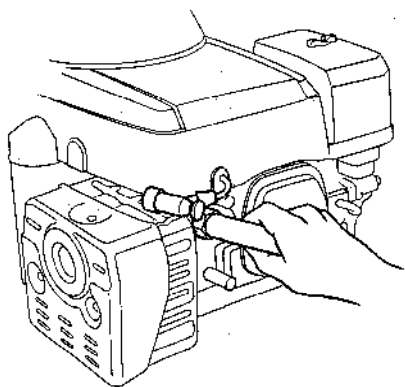

5. After the spark plug is seated, tighten with a spark plug wrench to compress the washer.

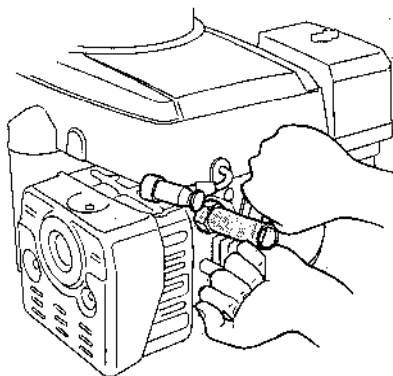

**NOTE:** When installing a new spark plug, tighten  $1/2$  turn after the spark plug seats to compress the washer. If reinstalling a used spark plug, tighten  $1/8 - 1/4$  turn after the spark plug seats to compress the washer.

**CAUTION:** The spark plug must be securely tightened. An improperly tightened spark plug can become very hot and may damage the engine.

---

#### 4. Fuel mixture adjustment

Refer to the fuel mixture adjustment instructions of the LPG equipment manufacturer.

After fuel mixture is correctly adjusted, turn the throttle stop screw to obtain the standard idle speed.

**Standard idle speed: 1,400rpm  $\pm$  150 (No load).**

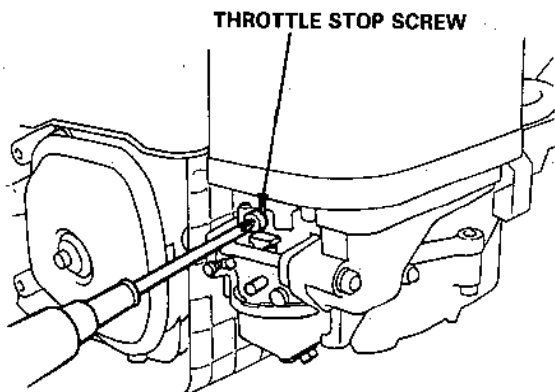

## 10. TRANSPORTING/STORAGE

### WARNING

- To avoid severe burns or fire hazards, let the engine cool before transporting it or storing it indoors.
- When transporting the engine, turn the fuel valve to the OFF position.

Before storing the unit for an extended period;

1. Be sure the storage area is free of excessive humidity and dust.
2. Turn the fuel valve OFF at the source.

### WARNING

**LPG is extremely flammable and is explosive under certain conditions. Do not smoke or allow flames or sparks in the area.**

3. Change the engine oil (page 16).
4. Remove the spark plug and pour about a tablespoon of clean engine oil into the cylinder. Crank the engine several revolutions to distribute the oil, then reinstall the spark plug.
5. Pull the starter rope slowly until resistance is felt. This closes the valves and will help to protect the engine from internal corrosion.

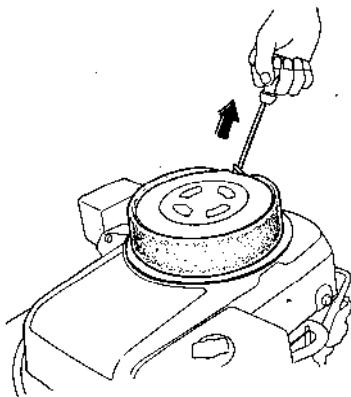

6. Cover the engine to keep out dust.

## 11. TROUBLESHOOTING

---

Engine will not start using recoil starter:

1. Is the control lever in the START position?
2. Is the fuel valve ON?
3. Is there fuel in the fuel tank?
4. Is fuel reaching the engine?
5. Is there a spark at the spark plug?

 **WARNING** Be sure the area is free of fuel vapor before testing the spark plug; fuel vapor may ignite.

- a. Remove the spark plug cap. Clean any dirt from around the spark plug base, then remove the spark plug.
  - b. Install the spark plug in the plug cap.
  - c. Turn the engine switch on.
  - d. Ground the side electrode to any engine ground, and then pull the recoil starter to see if sparks jump across the gap.
  - e. If there is no spark, replace the plug.  
If OK, reinstall the spark plug and try to start the engine again according to the instructions.
6. If the engine still does not start, take the engine to an authorized Honda engine dealer.



## 12. SPECIFICATIONS

Dimensions	GXV340	
Description code	GJ02	
Length x Width x Height	AC starter type 430 x 405 x 410 mm (16.9 x 15.9 x 16.1 in)	Other type 430 x 385 x 410 mm (16.9 x 15.1 x 16.1 in)
Dry weight	AC starter type 35.5 kg (78.3 lb)	Other type 32 kg (70.5 lb)

### Engine

Engine type	4-stroke, overhead valve, single cylinder
Displacement (Bore x Stroke)	337 cc (20.6 cu in) [82 x 64 mm (3.2 x 2.5 in)]
Max. output	11 HP/3,600 rpm
Max. torque	2.45 kg-m (17.7 ft-lb)/2,500 rpm
Fuel consumption	230 g/HPh
Cooling system	Forced air
Ignition system	Transistorized magneto
PTO shaft rotation	Counterclockwise

# 13. WIRING DIAGRAM

B	BLACK
Y	YELLOW
G	GREEN
R	RED
W	WHITE

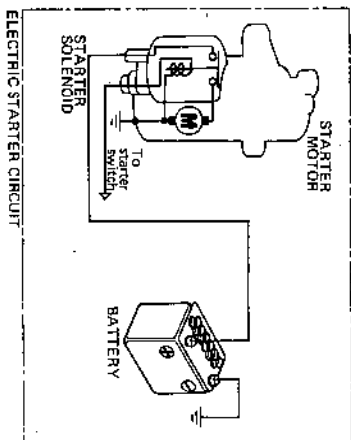
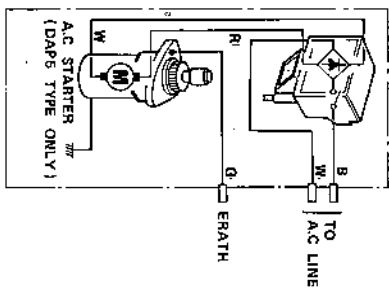
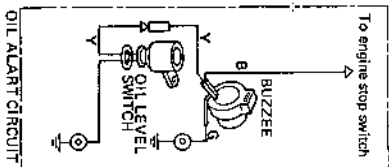
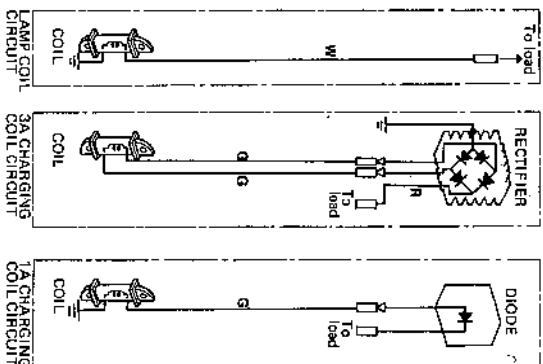
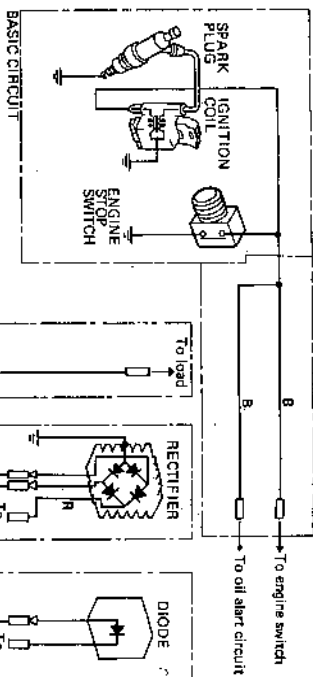

### Owner Satisfaction

Your satisfaction and goodwill are important to your dealer and to us. All Honda warranty details are explained in the Distributor's Limited Warranty. Warranty service is available at any dealership displaying the Honda Power Equipment Engines sign. To locate dealers in your area, look in the yellow pages of your telephone directory under Gasoline Engines, Garden & Lawn Equipment & Supplies, Lawn Mowers, etc.



Normally, any problem concerning the engine will be handled by the dealer's service department. If you have a warranty problem that has not been handled to your satisfaction, we suggest you take the following action:

- Discuss your problem with a member of dealership management. Often complaints can be quickly resolved at that level. If the problem has already been reviewed with the Service Manager, contact the owner of the dealership or the General Manager.
- If your problem still has not been resolved to your satisfaction, contact the Power Equipment Customer Relations Department of American Honda Motor Co., Inc.

American Honda Motor Co., Inc.  
Power Equipment Customer Relations Department  
P.O. Box 50  
Gardena, California 90247-0805  
Telephone: (213) 604-2400

We still need the following information in order to assist you:

- Your name, address, and telephone number
- Engine model and serial number
- Date of purchase
- Dealer name and address
- Product or equipment in which the engine is installed.
- Nature of the problem

After reviewing all the facts involved, you will be advised of what action can be taken. Please bear in mind that your problem will likely be resolved at the dealership, using the dealer's facilities, equipment, and personnel, so it is very important that your initial contact be with the dealer.

Your purchase of a Honda engine is greatly appreciated by both your dealer and American Honda Motor Co., Inc. We want to assist you in every way possible to assure your complete satisfaction with your purchase.

## **Current customer service contact information:**

Servicing dealership personnel are trained professionals. They should be able to answer any question you may have. If you encounter a problem that your dealer does not solve to your satisfaction, please discuss it with the dealership's management. The Service Manager, General Manager, or Owner can help. Almost all problems are solved in this way.

### **United States, Puerto Rico, and U.S. Virgin Islands:**

If you are dissatisfied with the decision made by the dealership's management, contact the Honda Regional Engine Distributor for your area ([www.honda-engines.com/dea.htm](http://www.honda-engines.com/dea.htm)).

If you are still dissatisfied after speaking with the Regional Engine Distributor, you may contact the Honda Office as shown.

American Honda Motor Co., Inc.  
Power Equipment Division  
Customer Relations Office  
4900 Marconi Drive  
Alpharetta, GA 30005-8847

Or telephone: (770) 497-6400 M-F, 8:30 am - 7:00 pm EST

When you write or call, please provide the following information:

- Equipment manufacturer's name and model number that the engine is mounted on
- Engine model, serial number, and type
- Name of the dealer who sold the engine to you
- Name, address, and contact person of the dealer who services your engine
- Date of purchase
- Your name, address, and telephone number
- A detailed description of the problem

---

**MEMO**

---

**MEMO**

---

**MEMO**





**HONDA**  
HONDA MOTOR CO., LTD. TOKYO, JAPAN

31ZE9606  
00X31-ZE9-6061

Ⓐ Ⓑ Ⓒ 10008903  
PRINTED IN JAPAN