

HONDA

ENGINES

Owner's Manual

GXV120

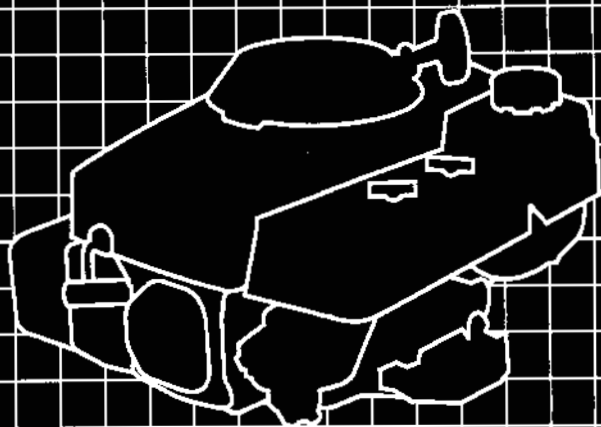



WARNING:



The engine exhaust from this product contains chemicals known to the State of California to cause cancer, birth defects or other reproductive harm.

Keep this owner's manual handy, so you can refer to it at any time. This owner's manual is considered a permanent part of the engine and should remain with the engine if resold.

The information and specifications included in this publication were in effect at the time of approval for printing. Honda Motor Co., Ltd. reserves the right, however, to discontinue or change specifications or design at any time without notice and without incurring any obligation whatever. No part of this publication may be reproduced without written permission.

INTRODUCTION

Congratulations on your selection of a Honda engine. We are certain you will be pleased with your purchase of one of the finest engines on the market.

We want to help you get the best results from your new engine and to operate it safely. This manual contains the information on how to do that; please read it carefully.

As you read this manual, you will find information preceded by a **NOTICE** symbol. That information is intended to help you avoid damage to your engine, other property, or the environment.

We suggest you read the warranty policy to fully understand its coverage and your responsibilities of ownership. The warranty policy is a separate document that should have been given to you by your dealer.

When your engine needs scheduled maintenance, keep in mind that your Honda servicing dealer is specially trained in servicing Honda engines. Your Honda servicing dealer is dedicated to your satisfaction and will be pleased to answer your questions and concerns.

Best Wishes,
Honda Motor Co., Ltd.

INTRODUCTION

A FEW WORDS ABOUT SAFETY

Your safety and the safety of others are very important. And using this engine safely is an important responsibility.

To help you make informed decisions about safety, we have provided operating procedures and other information on labels and in this manual. This information alerts you to potential hazards that could hurt you or others.

Of course, it is not practical or possible to warn you about all the hazards associated with operating or maintaining an engine. You must use your own good judgment.

You will find important safety information in a variety of forms, including:

- **Safety Messages** — preceded by a safety alert symbol  and one of three signal words, DANGER, WARNING, or CAUTION.

These signal words mean:

 **DANGER**

You **WILL** be **KILLED** or **SERIOUSLY HURT** if you don't follow instructions.

 **WARNING**

You **CAN** be **KILLED** or **SERIOUSLY HURT** if you don't follow instructions.

 **CAUTION**

You **CAN** be **HURT** if you don't follow instructions.

- **Safety Headings** — such as *IMPORTANT SAFETY INFORMATION*.
- **Safety Section** — such as *ENGINE SAFETY*.
- **Instructions** — how to use this engine correctly and safely.

This entire book is filled with important safety information — please read it carefully.

CONTENTS

ENGINE SAFETY	5
IMPORTANT SAFETY INFORMATION	5
CONTROLS	7
COMPONENT & CONTROL LOCATIONS	7
CONTROLS	8
Fuel Valve Lever	8
Control Lever	9
Recoil Starter Grip	10
Switch for Electric Starter (applicable engine types)	11
BEFORE OPERATION	12
IS YOUR ENGINE READY TO GO?	12
Check the General Condition of the Engine	12
Check the Engine	13
Check the Equipment Powered by This Engine	13
OPERATION	14
SAFE OPERATING PRECAUTIONS	14
STARTING THE ENGINE	14
STOPPING THE ENGINE	17
SETTING ENGINE SPEED	18
SERVICING YOUR HONDA ENGINE	19
THE IMPORTANCE OF MAINTENANCE	19
MAINTENANCE SAFETY	20
MAINTENANCE SCHEDULE	21
REFUELING	22
FUEL RECOMMENDATIONS	23
ENGINE OIL LEVEL CHECK	24
ENGINE OIL CHANGE	25
ENGINE OIL RECOMMENDATIONS	26
AIR FILTER INSPECTION	27
AIR CLEANER SERVICE	28
SPARK PLUG SERVICE	30
IDLE SPEED ADJUSTMENT	31
SPARK ARRESTER MAINTENANCE (optional equipment)	32

CONTENTS

HELPFUL TIPS & SUGGESTIONS	33
STORING YOUR ENGINE	33
Storage Preparation	33
Storage Precautions	36
Removal From Storage	37
TRANSPORTING	38
TAKING CARE OF UNEXPECTED PROBLEMS	39
ENGINE WILL NOT START	39
ENGINE LACKS POWER	39
TECHNICAL & CONSUMER INFORMATION	40
TECHNICAL INFORMATION	40
Serial Number Location	40
Battery Connections for Electric Starter	41
Carburetor Modification for High Altitude Operation	42
Oxygenated Fuels	43
Emission Control System Information	44
Air Index	46
Specifications	47
CONSUMER INFORMATION	48
Honda Publications	48
Customer Service Information	49
QUICK REFERENCE INFORMATION	Inside back cover

ENGINE SAFETY

IMPORTANT SAFETY INFORMATION

Most accidents with engines can be prevented if you follow all instructions in this manual and on the engine. Some of the most common hazards are discussed below, along with the best way to protect yourself and others.

Owner Responsibilities

- Honda engines are designed to give safe and dependable service if operated according to instructions. Read and understand this owner's manual before operating the engine. Failure to do so could result in personal injury or equipment damage.
- Know how to stop the engine quickly, and understand the operation of all controls. Never permit anyone to operate the engine without proper instructions.
- Do not allow children to operate the engine. Keep children and pets away from the area of operation.

Refuel With Care

Gasoline is extremely flammable, and gasoline vapor can explode. Refuel outdoors, in a well-ventilated area, with the engine stopped. Never smoke near gasoline, and keep other flames and sparks away. Always store gasoline in an approved container. If any fuel is spilled, make sure the area is dry before starting the engine.

Hot Exhaust

- The muffler becomes very hot during operation and remains hot for a while after stopping the engine. Be careful not to touch the muffler while it is hot. Let the engine cool before storing it indoors.
- To prevent fire hazards and to provide adequate ventilation for stationary equipment applications, keep the engine at least 3 feet (1 meter) away from building walls and other equipment during operation. Do not place flammable objects close to the engine.

ENGINE SAFETY

Carbon Monoxide Hazard

Exhaust gas contains poisonous carbon monoxide. Avoid inhalation of exhaust gas. Never run the engine in a closed garage or confined area.

Other Equipment

Review the instructions provided with the equipment powered by this engine for any additional safety precautions that should be observed in conjunction with engine startup, shutdown, or operation, or protective apparel that may be needed to operate the equipment.

CONTROLS

COMPONENT & CONTROL LOCATIONS

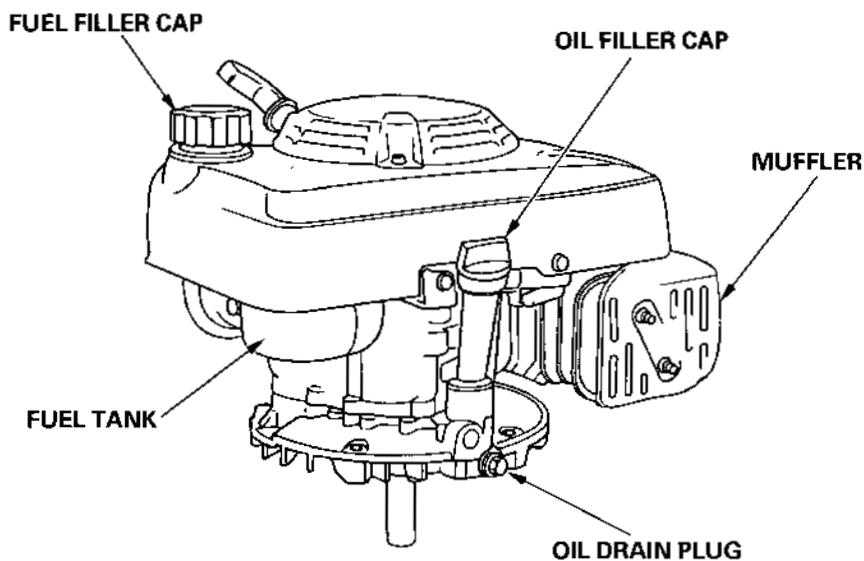
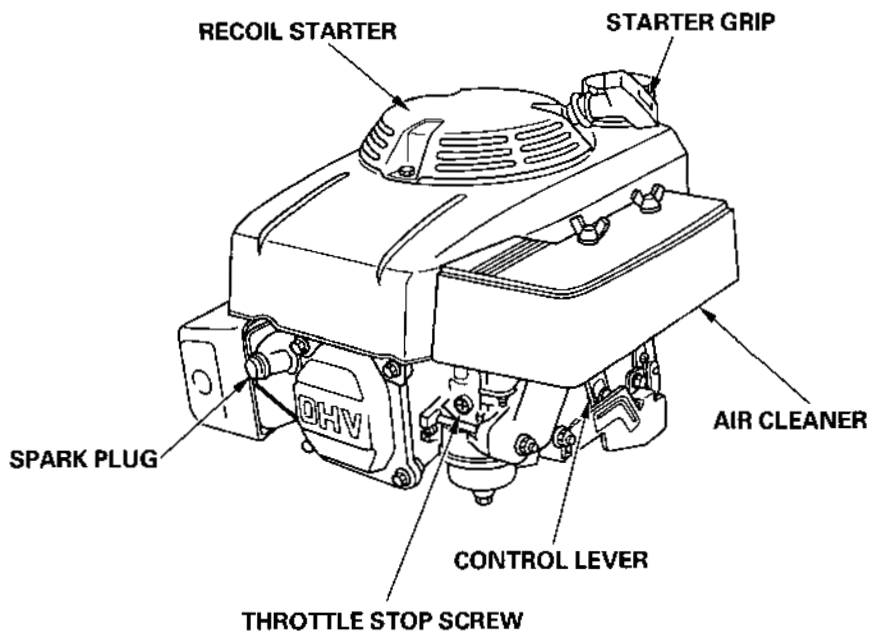

CONTROLS

CONTROLS

Fuel Valve Lever

The fuel valve opens and closes the passage between the fuel tank and the carburetor.

The fuel valve lever must be in the ON position for the engine to run.

When the engine is not in use, leave the fuel valve lever in the OFF position to prevent carburetor flooding and to reduce the possibility of fuel leakage.

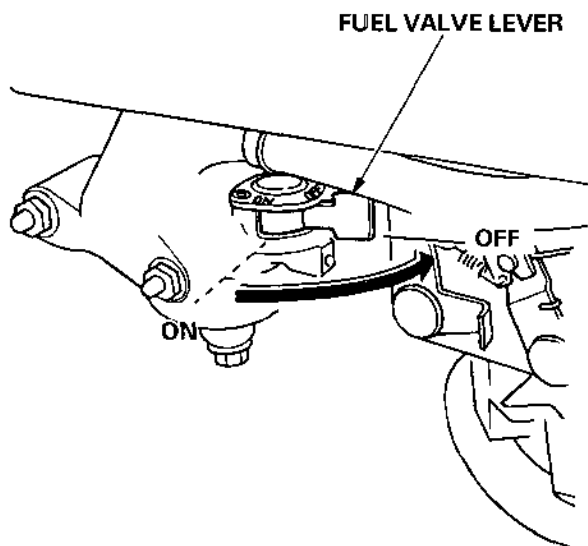

Control Lever

The control lever operates the ignition switch, throttle, and choke.

STOP ——— Stops the engine by switching off the ignition system. All other control lever positions leave the ignition system switched on.

SLOW ——— For running the engine at idle speed.

FAST ——— For restarting a warm engine, and for running the engine at maximum speed.

CHOKE ——— Enriches the fuel mixture for starting a cold engine.

The control lever shown here will be connected to a remote control on the equipment powered by this engine. Refer to the instructions provided with that equipment for remote control information.

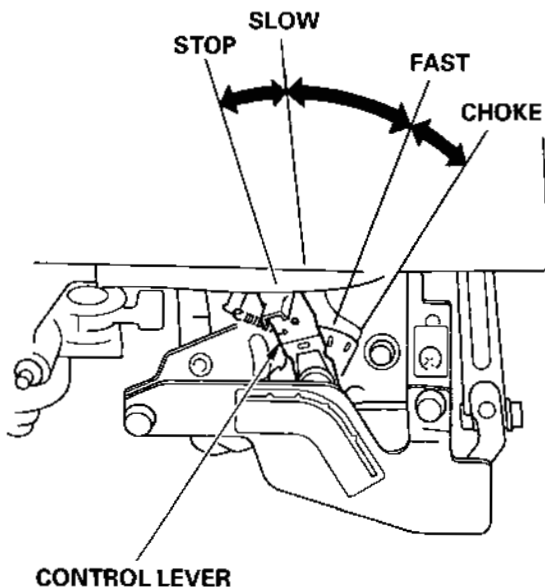

CONTROLS

Recoil Starter Grip

Pulling the starter grip operates the recoil starter to crank the engine.

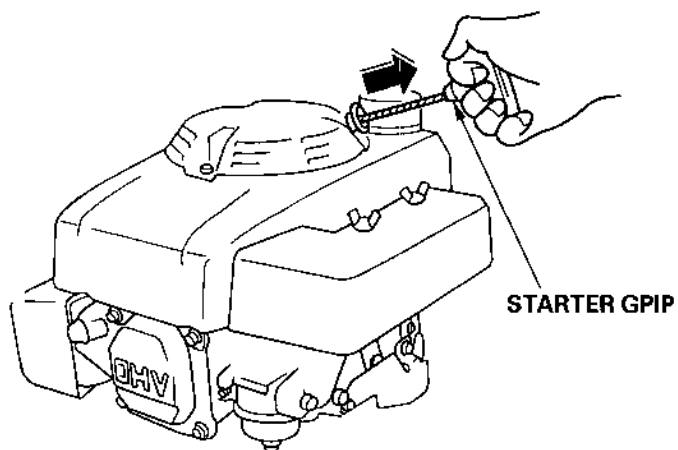

Switch for Electric Starter (applicable engine types)

The electric starter will be connected to a remote control on the equipment powered by this engine. Refer to the instructions provided that equipment for remote control information.

BEFORE OPERATION

IS YOUR ENGINE READY TO GO?

For your safety, and to maximize the service life of your equipment, it is very important to take a few moments before you operate the engine to check its condition. Be sure to take care of any problem you find, or have your servicing dealer correct it, before you operate the engine.

⚠ WARNING

Improperly maintaining this engine, or failing to correct a problem before operation, could cause a malfunction in which you could be seriously injured.

Always perform a preoperation inspection before each operation, and correct any problem.

Before beginning your preoperation checks, be sure the engine is level and the engine switch is in the OFF position.

Check the General Condition of the Engine

- Look around and underneath the engine for signs of oil or gasoline leaks.
- Remove any excessive dirt or debris, especially around the muffler and recoil starter.
- Look for signs of damage.
- Check that all shields and covers are in place, and all nuts, bolts, and screws are tightened.

Check the Engine

- Check the engine oil level (see page 24). Running the engine with a low oil level can cause engine damage.
- Check the air filter (see page 27). A dirty air filter will restrict air flow to the carburetor, reducing engine performance.
- Check the fuel level. Starting with a full tank will help to eliminate or reduce operating interruptions for refueling.

Check the Equipment Powered by This Engine

Review the instructions provided with the equipment powered by this engine for any precautions and procedures that should be followed before engine startup.

OPERATION

SAFE OPERATING PRECAUTIONS

Before operating the engine for the first time, please review the *IMPORTANT SAFETY INFORMATION* on page 5 and the chapter titled *BEFORE OPERATION*.

⚠ WARNING

Carbon monoxide gas is toxic.
Breathing it can cause
unconsciousness and even kill you.

Avoid any areas or actions that
expose you to carbon monoxide.

Review the instructions provided with the equipment powered by this engine for any safety precautions that should be observed in conjunction with engine startup, shutdown, or operation.

STARTING THE ENGINE

1. Move the fuel valve lever to the ON position.

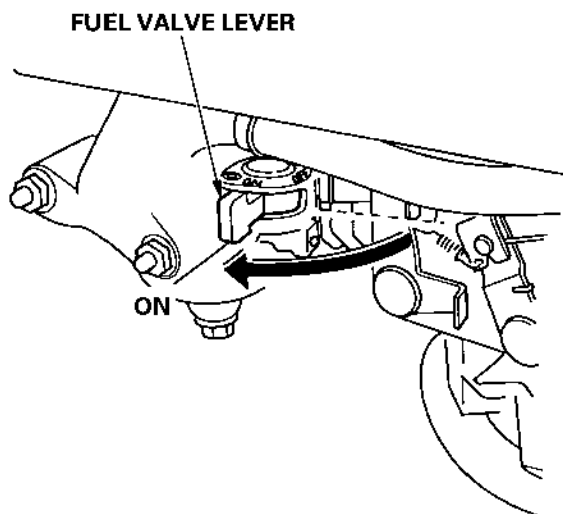

2. To start a cold engine, move the control lever to the CHOKE position.

To restart a warm engine, leave the control lever in the FAST position.

The control lever shown here will be connected to a remote control on the equipment powered by this engine. Refer to the instructions provided with that equipment for remote control information.

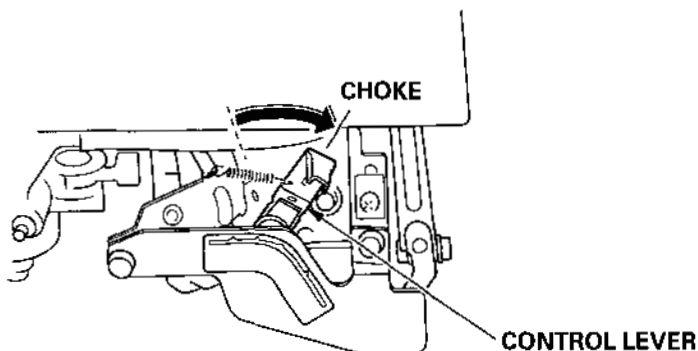

3. Operate the starter.

RECOIL STARTER (all engine types):

Pull the starter grip lightly until you feel resistance, then pull briskly. Return the starter grip gently.

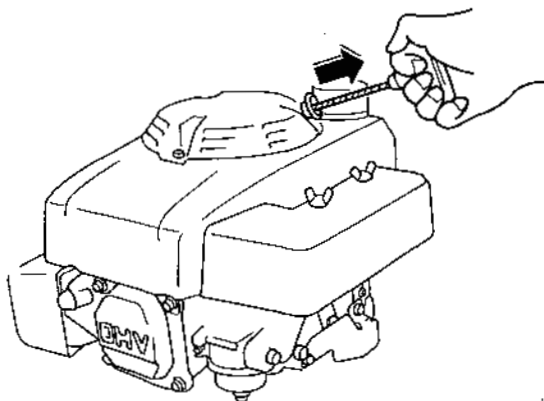

OPERATION

ELECTRIC STARTER (applicable engine types):

The electric starter will be connected to a remote control on the equipment powered by this engine. Refer to the instructions provided that equipment for remote control information.

If the engine fails to start within 5 seconds, release the starter switch, and wait at least 10 seconds before operating the starter again.

NOTICE

Using the electric starter for more than 5 seconds at a time will overheat the starter motor and can damage it.

4. If the control lever has been moved to the **CHOKER** position to start the engine, gradually move it to the **FAST** or **SLOW** position as the engine warms up.

The control lever shown here will be connected to a remote control on the equipment powered by this engine. Refer to the instructions provided with that equipment for remote control information.

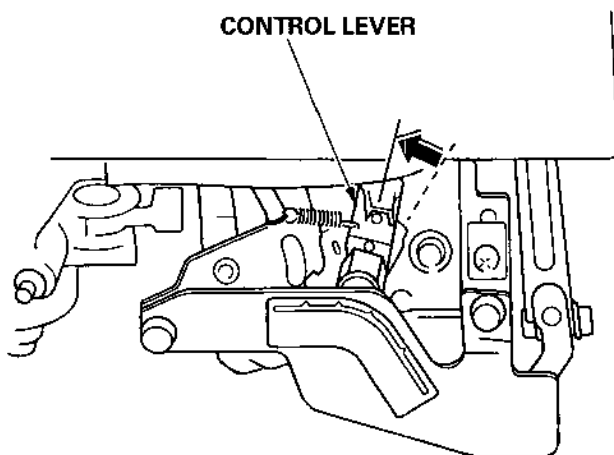

STOPPING THE ENGINE

1. Move the control lever to the STOP position.

The control lever shown here will be connected to a remote control on the equipment powered by this engine. Refer to the instructions provided with that equipment for remote control information.

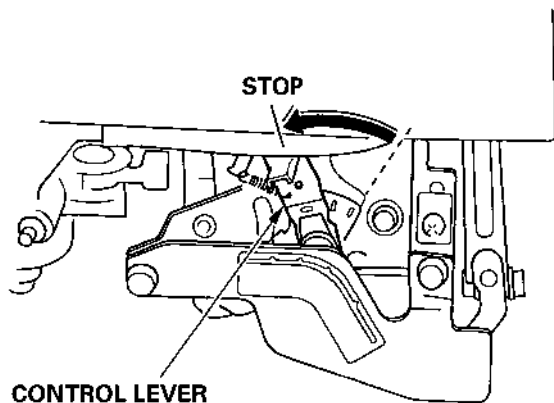

2. Turn the fuel valve lever to the OFF position.

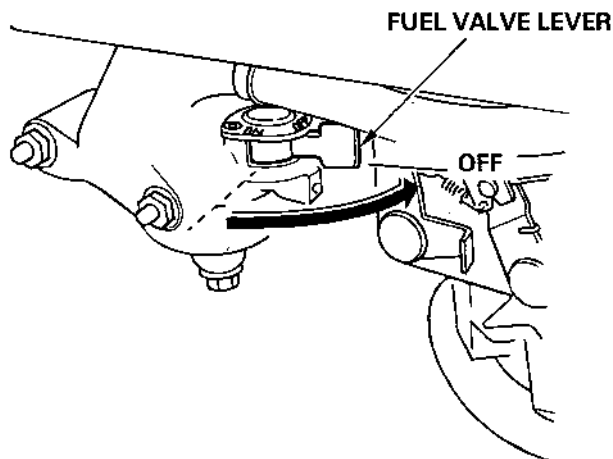

OPERATION

SETTING ENGINE SPEED

Position the control lever for the desired engine speed.

The control lever shown here will be connected to a remote control on the equipment powered by this engine. Refer to the instructions provided with that equipment for remote control information and engine speed recommendations.

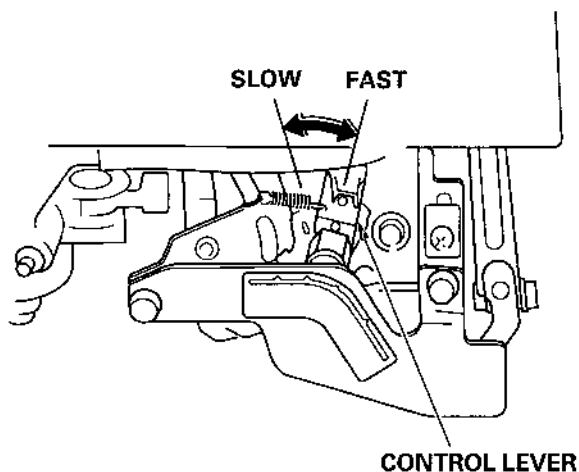

SERVICING YOUR ENGINE

THE IMPORTANCE OF MAINTENANCE

Good maintenance is essential for safe, economical, and trouble-free operation. It will also help reduce air pollution.

⚠ WARNING

Improperly maintaining this engine, or failure to correct a problem before operation, can cause a malfunction in which you can be seriously hurt or killed.

Always follow the inspection and maintenance recommendations and schedules in this owner's manual.

To help you properly care for your engine, the following pages include a maintenance schedule, routine inspection procedures, and simple maintenance procedures using basic hand tools. Other service tasks that are more difficult, or require special tools, are best handled by professionals and are normally performed by a Honda technician or other qualified mechanic.

The maintenance schedule applies to normal operating conditions. If you operate your engine under unusual conditions, such as sustained high-load or high-temperature operation, or use in unusually wet or dusty conditions, consult your servicing dealer for recommendations applicable to your individual needs and use.

Maintenance, replacement or repair of emission control devices and systems may be done by any engine repair establishment or individual, using parts that are "certified" to EPA standards.

SERVICING YOUR ENGINE

MAINTENANCE SAFETY

Some of the most important safety precautions follow. However, we cannot warn you of every conceivable hazard that can arise in performing maintenance. Only you can decide whether or not you should perform a given task.

▲ WARNING

Failure to properly follow maintenance instructions and precautions can cause you to be seriously hurt or killed.

Always follow the procedures and precautions in the owner's manual.

Safety Precautions

- Make sure the engine is off before you begin any maintenance or repairs. This will eliminate several potential hazards:
 - **Carbon monoxide poisoning from engine exhaust.**
Be sure there is adequate ventilation whenever you operate the engine.
 - **Burns from hot parts.**
Let the engine and exhaust system cool before touching.
 - **Injury from moving parts.**
Do not run the engine unless instructed to do so.
- Read the instructions before you begin, and make sure you have the tools and skills required.
- To reduce the possibility of fire or explosion, be careful when working around gasoline. Use only a nonflammable solvent, not gasoline, to clean parts. Keep cigarettes, sparks and flames away from all fuel-related parts.

Remember that your servicing dealer knows your engine best and is fully equipped to maintain and repair it.

To ensure the best quality and reliability, use only new, genuine Honda parts or their equivalents for repair and replacement.

SERVICING YOUR ENGINE

MAINTENANCE SCHEDULE

REGULAR SERVICE PERIOD (3)		Each use	First month or 20 Hrs.	Every 3 months or 50 Hrs.	Every 6 months or 100 Hrs.	Every year or 200 Hrs.	Refer to page	
ITEM	Perform at every indicated month or operating hour interval, whichever comes first.							
•	Engine oil	Check level	○				24	
		Change		○		○	25	
•	Air filter	Check	○				27	
		Clean			○ (1)		28	
		Replace					○*	
•	Spark plug	Check-adjust				○	30	
		Replace				○		
	Spark arrester (optional part)	Clean				○	32	
•	Idle speed	Check-adjust				○ (2)	31	
•	Valve clearance	Check-adjust				○ (2)	—	
•	Combustion chamber	Clean	After every 250 hrs (2)					—
•	Fuel tank and filter	Clean				○ (2)	—	
•	Fuel tube	Check	Every 2 years (Replace if necessary) (2)					—

• Emission-related items.

* Replace the paper element type only.

- (1) Service more frequently when used in dusty areas.
- (2) These items should be serviced by your servicing dealer, unless you have the proper tools and are mechanically proficient. Refer to Honda shop manual for service procedures.
- (3) For commercial use, log hours of operation to determine proper maintenance intervals.

SERVICING YOUR ENGINE

REFUELING

Fuel tank capacity: 0.26 US gal (1.0 ℓ , 0.22 Imp gal)

With the engine stopped, remove the fuel tank cap and check the fuel level. Refill the tank if the fuel level is low.

⚠ WARNING

Gasoline is highly flammable and explosive.

You can be burned or seriously injured when handling fuel.

- Stop the engine and keep heat, sparks, and flame away.
- Handle fuel only outdoors.
- Wipe up spills immediately.

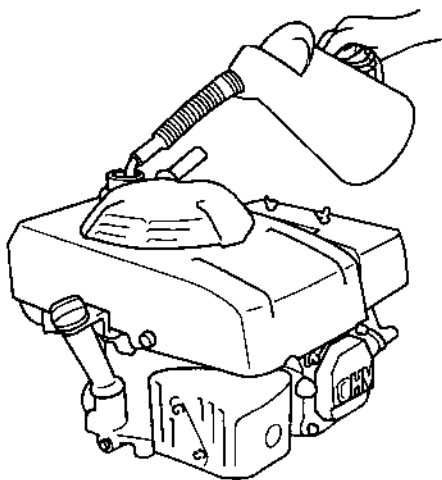

SERVICING YOUR ENGINE

Refuel in a well-ventilated area before starting the engine. If the engine has been running, allow it to cool. Refuel carefully to avoid spilling fuel. Do not overfill. After refueling, tighten the fuel tank cap securely.

Never refuel the engine inside a building where gasoline fumes may reach flames or sparks. Keep gasoline away from appliance pilot lights, barbecues, electric appliances, power tools, etc.

Spilled fuel is not only a fire hazard, it causes environmental damage. Wipe up spills immediately.

NOTICE

Fuel can damage paint and plastic. Be careful not to spill fuel when filling your fuel tank. Damage caused by spilled fuel is not covered under warranty.

FUEL RECOMMENDATIONS

Use unleaded gasoline with a pump octane rating of 86 or higher.

These engines are certified to operate on unleaded gasoline. Unleaded gasoline produces fewer engine and spark plug deposits and extends exhaust system life.

Never use stale or contaminated gasoline or an oil/gasoline mixture. Avoid getting dirt or water in the fuel tank.

Occasionally you may hear a light "spark knock" or "pinging" (metallic rapping noise) while operating under heavy loads. This is no cause for concern.

If spark knock or pinging occurs at a steady engine speed, under normal load, change brands of gasoline. If spark knock or pinging persists, see an authorized Honda servicing dealer.

NOTICE

Running the engine with persistent spark knock or pinging can cause engine damage.

Running the engine with persistent spark knock or pinging is misuse, and the Distributor's Limited Warranty does not cover parts damaged by misuse.

SERVICING YOUR ENGINE

ENGINE OIL LEVEL CHECK

Check the engine oil level with the engine stopped and in a level position.

1. Remove the filler cap/dipstick and wipe it clean.
2. Insert and remove the dipstick without screwing it into the filler neck. Check the oil level shown on the dipstick.
3. If the oil level is near or below the lower limit mark on the dipstick, and fill with the recommended oil to the upper limit mark (see page 26).
4. Screw in the filler cap/dipstick securely.

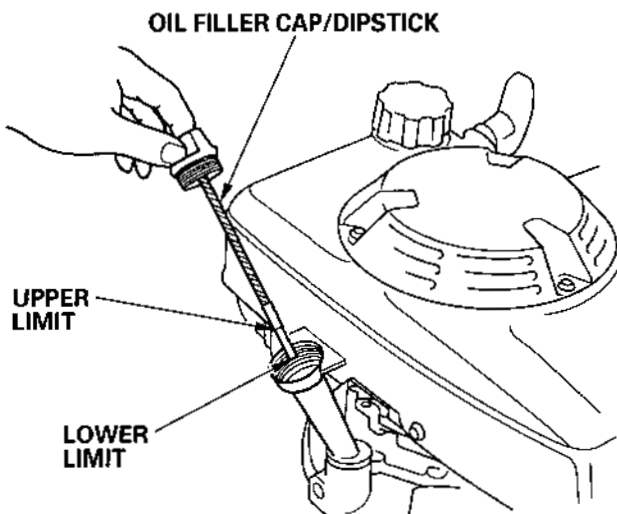

NOTICE

Running the engine with a low oil level can cause engine damage.

ENGINE OIL CHANGE

Drain the used oil while the engine is warm. Warm oil drains quickly and completely.

1. Place a suitable container below the engine to catch the used oil, then remove the filler cap/dipstick and the drain plug.
2. Allow the used oil to drain completely, then reinstall the drain plug, and tighten it securely.
3. Please dispose of used motor oil in a manner that is compatible with the environment. We suggest you take used oil in a sealed container to your local recycling center or service station for reclamation. Do not throw it in the trash, pour it on the ground, or down a drain.
4. With the engine in a level position, fill to the upper limit mark on the dipstick with the recommended oil (see page 26).

Engine oil capacity: 0.63 US qt (0.60 ℓ, 0.53 Imp qt)

NOTICE

Running the engine with a low oil level can cause engine damage.

5. Screw in the filler cap/dipstick securely.

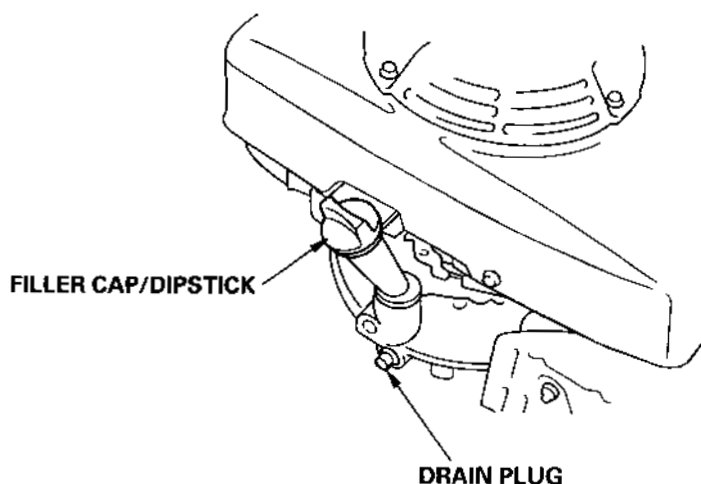

SERVICING YOUR ENGINE

ENGINE OIL RECOMMENDATIONS

Oil is a major factor affecting performance and service life. Use 4-stroke automotive detergent oil.

SAE 10W-30 is recommended for general use. Other viscosities shown in the chart may be used when the average temperature in your area is within the recommended range.

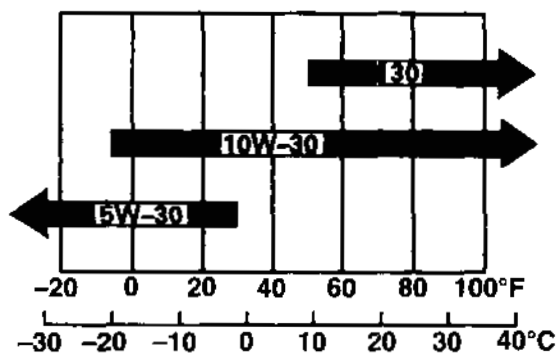

AMBIENT TEMPERATURE

The SAE oil viscosity and service classification are in the API label on the oil container. Honda recommends that you use API SERVICE category SJ oil.

SERVICING YOUR ENGINE

AIR FILTER INSPECTION

Remove the two wing bolts, and remove the air cleaner cover. Check the air filter to be sure it is clean and in good condition.

If the air filter elements are dirty, clean or replace them as described on page 28. Damaged filter elements must be replaced.

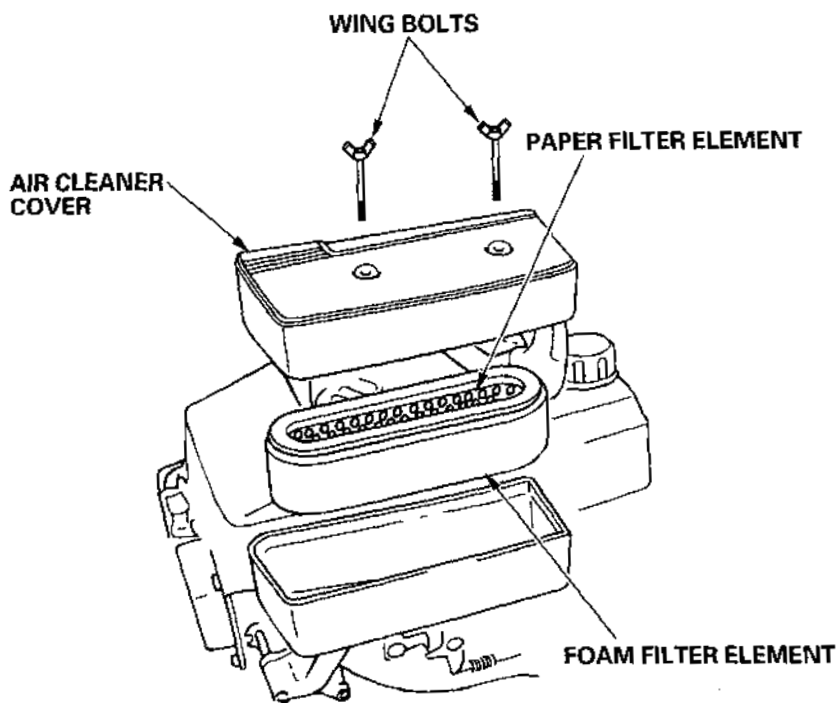

SERVICING YOUR ENGINE

AIR CLEANER SERVICE

A dirty air filter will restrict air flow to the carburetor, reducing engine performance. If you operate the engine in very dusty areas, clean the air filter more often than specified in the MAINTENANCE SCHEDULE.

NOTICE

Operating the engine without an air filter, or with a damaged air filter, will allow dirt to enter the engine, causing rapid engine wear. This type of damage is not covered by the Distributor's Limited Warranty.

1. Remove the two wing bolts from the air cleaner cover, and remove the cover.
2. Remove the filter, and remove the foam filter from the paper filter.
3. Inspect both air filter elements, and replace them if they are damaged. Always replace the paper air filter element at the scheduled interval (see page 21).

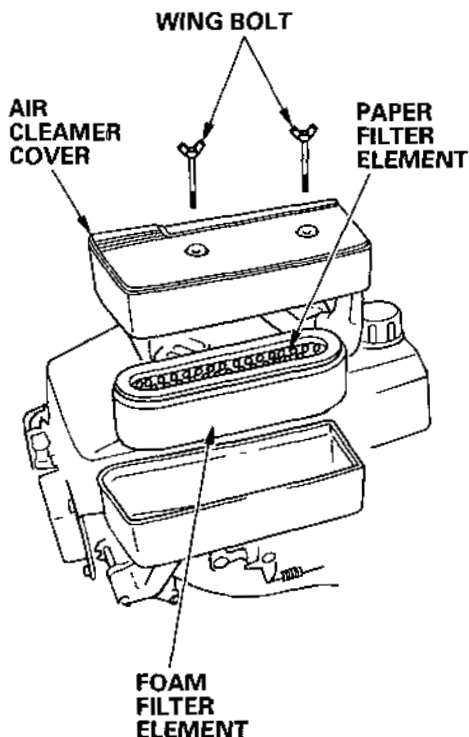

4. Clean the air filter elements if they are to be reused.

Paper air filter element: Tap the filter element several times on a hard surface to remove dirt, or blow compressed air [not exceeding 30 psi (207 kPa, 2.1 kgf/cm²)] through the filter element from the inside. Never try to brush off dirt; brushing will force dirt into the fibers.

Foam air filter element: Clean in warm soapy water, rinse, and allow to dry thoroughly. Or clean in nonflammable solvent and allow to dry. Dip the filter element in clean engine oil, then squeeze out all excess oil. The engine will smoke when started if too much oil is left in the foam.

5. Wipe dirt from the inside of the air cleaner base and cover, using a moist rag. Be careful to prevent dirt from entering the air duct that leads to the carburetor.
6. Place the foam air filter element over the paper element, and reinstall the assembled air filter.
7. Install the air cleaner cover, and tighten the two cover wing bolts securely.

SERVICING YOUR ENGINE

SPARK PLUG SERVICE

Recommended spark plugs: BP5ES, BPR5ES (NGK)
W16EP-U, W16EPR-U (DENSO)

NOTICE

An incorrect spark plug can cause engine damage.

1. Disconnect the spark plug cap, and remove any dirt from around the spark plug area.
2. Remove the spark plug with a 13/16-inch spark plug wrench.

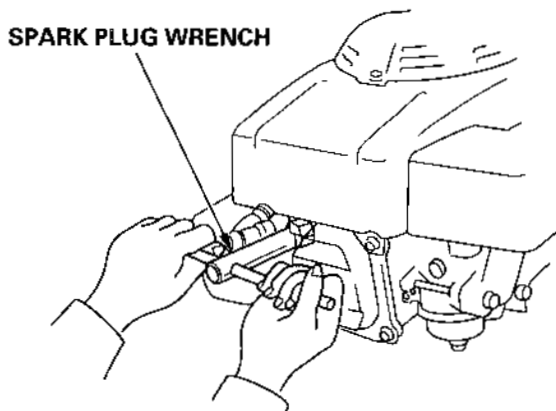

3. Inspect the spark plug. Replace it if the electrodes are worn, or if the insulator is cracked or chipped. Clean the spark plug with a wire brush if you are going to reuse it.

4. Measure the spark plug electrode gap with a suitable gauge. The gap should be 0.028 – 0.031 in (0.70 – 0.80 mm). Correct the gap, if necessary, by carefully bending the side electrode.

5. Install the spark plug carefully, by hand, to avoid cross-threading.

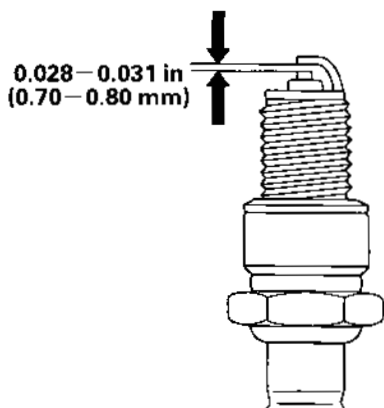

6. After the spark plug seats, tighten with a 13/16-inch spark plug wrench to compress the washer.

If reinstalling the used spark plug, tighten 1/8–1/4 turn after the spark plug seats.

If installing a new spark plug, tighten 1/2 turn after the spark plug seats.

NOTICE

A loose spark plug can overheat and damage the engine. Overtightening the spark plug can damage the threads in the cylinder head.

7. Attach the spark plug cap.

IDLE SPEED ADJUSTMENT

1. Start the engine outdoors, and allow it to warm up to operating temperature.
2. Move the control lever to its slowest position.
3. Turn the throttle stop screw to obtain the standard idle speed.

Standard idle speed: 2,000 ± 150 rpm

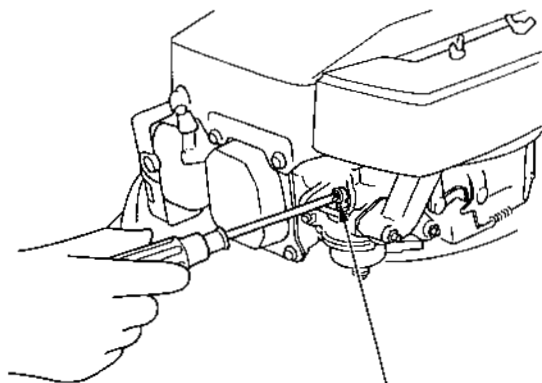

THROTTLE STOP SCREW

SERVICING YOUR ENGINE

SPARK ARRESTER SERVICE (optional equipment)

Your engine is not factory-equipped with a spark arrester. In some areas, it is illegal to operate an engine without a spark arrester. Check local laws and regulations. A spark arrester is available from authorized Honda servicing dealers.

The spark arrester must be serviced every 100 hours to keep it functioning as designed.

If the engine has been running, the muffler will be very hot. Allow the muffler to cool before servicing the spark arrester.

1. Loosen the two 6 mm nuts and remove the muffler protector, identification plate, muffler and gasket from the cylinder.
2. Remove the spark arrester from the muffler (take care not to damage the wire mesh).

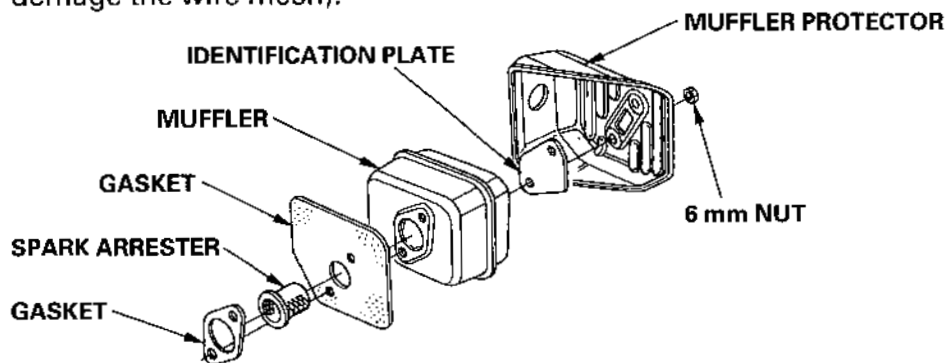

3. Use a brush to remove carbon deposits from the spark arrester screen. Be careful to avoid damaging the screen.

The spark arrester must be free of breaks and holes. Replace the spark arrester if it is damaged.

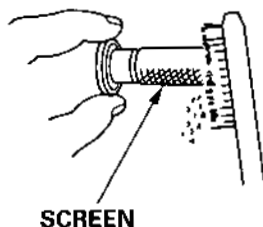

4. Install the spark arrester, muffler, and muffler protector in the reverse order of disassembly.

HELPFUL TIPS & SUGGESTIONS

STORING YOUR ENGINE

Storage Preparation

Proper storage preparation is essential for keeping your engine troublefree and looking good. The following steps will help to keep rust and corrosion from impairing your engine's function and appearance, and will make the engine easier to start when you use it again.

Cleaning

If the engine has been running, allow it to cool for at least half an hour before cleaning. Clean all exterior surfaces, touch up any damaged paint, and coat other areas that may rust with a light film of oil.

NOTICE

- *Using a garden hose or pressure washing equipment can force water into the air cleaner or muffler opening. Water in the air cleaner will soak the air filter, and water that passes through the air filter or muffler can enter the cylinder, causing damage.*
- *Water contacting a hot engine can cause damage. If the engine has been running, allow it to cool for at least half an hour before washing.*

Fuel

Gasoline will oxidize and deteriorate in storage. Old gasoline will cause hard starting, and it leaves gum deposits that clog the fuel system. If the gasoline in your engine deteriorates during storage, you may need to have the carburetor and other fuel system components serviced or replaced.

The length of time that gasoline can be left in your fuel tank and carburetor without causing functional problems will vary with such factors as gasoline blend, your storage temperatures, and whether the fuel tank is partially or completely filled. The air in a partially filled fuel tank promotes fuel deterioration. Very warm storage/temperatures accelerate fuel deterioration. Fuel deterioration problems may occur within a few months, or even less if the gasoline was not fresh when you filled the fuel tank.

HELPFUL TIPS & SUGGESTIONS

The *Distributor's Limited Warranty* does not cover fuel system damage or engine performance problems resulting from neglected storage preparation.

You can extend fuel storage life by adding a fuel stabilizer that is formulated for that purpose, or you can avoid fuel deterioration problems by draining the fuel tank and carburetor.

ADDING A FUEL STABILIZER TO EXTEND FUEL STORAGE LIFE

When adding a fuel stabilizer, fill the fuel tank with fresh gasoline. If only partially filled, air in the tank will promote fuel deterioration during storage. If you keep a container of gasoline for refueling, be sure that it contains only fresh gasoline.

1. Add fuel stabilizer following the manufacturer's instructions.
2. After adding a fuel stabilizer, run the engine outdoors for 10 minutes to be sure that treated gasoline has replaced the untreated gasoline in the carburetor.
3. Stop the engine, and move the fuel valve lever to the OFF position.

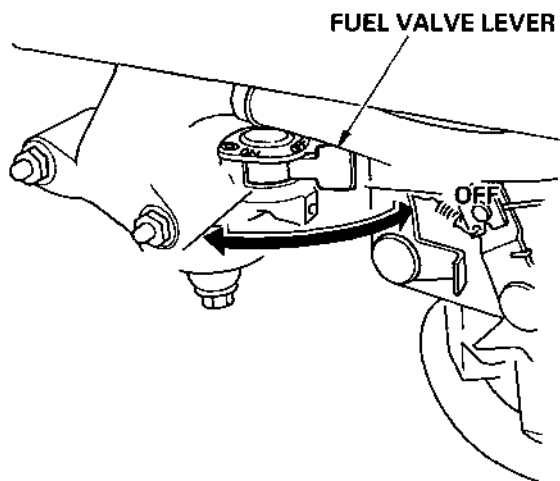

DRAINING THE FUEL TANK AND CARBURETOR

1. Place an approved gasoline container below the carburetor, and use a funnel to avoid spilling fuel.
2. Remove the carburetor drain bolt, then move the fuel valve lever to the ON position.

⚠ WARNING

Gasoline is highly flammable and explosive.

You can be burned or seriously injured when handling fuel.

- Keep heat, sparks and flame away.
- Handle fuel only outdoors.
- Wipe up spills immediately.

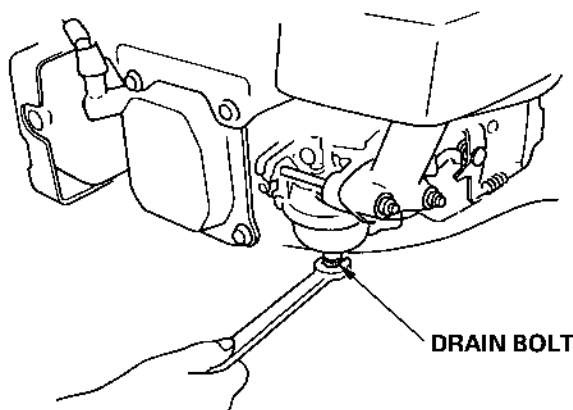

3. After all the fuel has drained into the container, reinstall the drain bolt, and tighten it securely.

HELPFUL TIPS & SUGGESTIONS

Engine Oil

1. Change the engine oil (see page 25).
2. Remove the spark plug (see page 30).
3. Pour a tablespoon (5–10 cc) of clean engine oil into the cylinder.
4. Pull the starter rope several times to distribute the oil in the cylinder.
5. Reinstall the spark plug.
6. Pull the starter rope slowly until resistance is felt. This will close the valves so moisture cannot enter the engine cylinder. Return the starter rope gently.

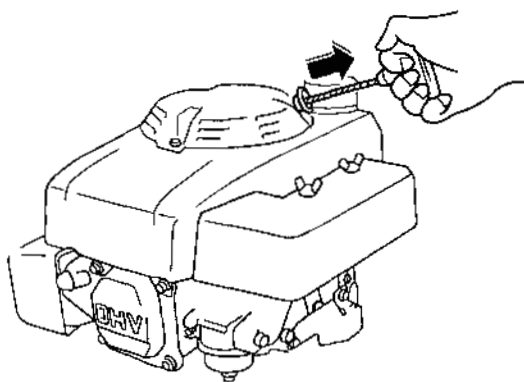

Storage Precautions

If your engine will be stored with gasoline in the fuel tank and carburetor, it is important to reduce the hazard of gasoline vapor ignition. Select a well-ventilated storage area away from any appliance that operates with a flame, such as a furnace, water heater, or clothes dryer. Also avoid any area with a spark-producing electric motor, or where power tools are operated.

If possible, avoid storage areas with high humidity, because that promotes rust and corrosion.

Unless all fuel has been drained from the fuel tank, leave the fuel valve lever in the OFF position to reduce the possibility of fuel leakage.

HELPFUL TIPS & SUGGESTIONS

Position the equipment so the engine is level. Tilting can cause fuel or oil leakage.

With the engine and exhaust system cool, cover the engine to keep out dust. A hot engine and exhaust system can ignite or melt some materials. Do not use sheet plastic as a dust cover. A nonporous cover will trap moisture around the engine, promoting rust and corrosion.

If equipped with a battery for an electric starter, recharge the battery once a month while the engine is in storage.

This will help to extend the service life of the battery.

Removal From Storage

Check your engine as described in the *BEFORE OPERATION* chapter of this manual.

If the fuel was drained during storage preparation, fill the tank with fresh gasoline. If you keep a container of gasoline for refueling, be sure that it contains only fresh gasoline. Gasoline oxidizes and deteriorates over time, causing hard starting.

If the cylinders were coated with oil during storage preparation, the engine may smoke briefly at startup. This is normal.

HELPFUL TIPS & SUGGESTIONS

TRANSPORTING

If the engine has been running, allow it to cool for at least 15 minutes before loading the engine-powered equipment on the transport vehicle. A hot engine and exhaust system can burn you and can ignite some materials.

Keep the engine level when transporting to reduce the possibility of fuel leakage. Turn the fuel valve lever to the OFF position.

TAKING CARE OF UNEXPECTED PROBLEMS

ENGINE WILL NOT START	Possible Cause	Correction
1. Electric starting: Check battery and fuse.	Battery discharged.	Recharge battery.
	Fuse burnt out.	Replace fuse
2. Check control positions.	Fuel valve OFF.	Move lever to ON.
	Choke OPEN.	Move lever to CHOKE position unless engine is warm.
	Engine switch OFF. (if equipped)	Turn engine switch to ON.
3. Check fuel.	Out of fuel.	Refuel (p. 22).
	Bad fuel; engine stored without treating or draining gasoline, or refueled with bad gasoline.	Drain fuel tank and carburetor (p. 35). Refuel with fresh gasoline (p. 22).
4. Remove and inspect spark plug.	Spark plugs faulty, fouled, or improperly gapped.	Clean, gap, or replace spark plug (p. 30).
	Spark plugs wet with fuel (flooded engine).	Dry and reinstall spark plug. Start engine with control lever in FAST position.
5. Take engine to an authorized Honda servicing dealer, or refer to shop manual.	Fuel strainer clogged, carburetor malfunction, ignition malfunction, valves stuck, etc.	Replace or repair faulty components as necessary.

ENGINE LACKS POWER	Possible Cause	Correction
1. Check air filter.	Filter elements clogged.	Clean or replace filter elements (p. 28).
2. Check fuel.	Bad fuel; engine stored without treating or draining gasoline, or refueled with bad gasoline.	Drain fuel tank and carburetor (p. 35). Refuel with fresh gasoline (p. 22).
3. Take engine to an authorized Honda servicing dealer, or refer to shop manual.	Fuel strainer clogged, carburetor malfunction, ignition malfunction, valves stuck, etc.	Replace or repair faulty components as necessary.

TECHNICAL & CONSUMER INFORMATION

TECHNICAL INFORMATION

Serial Number Location

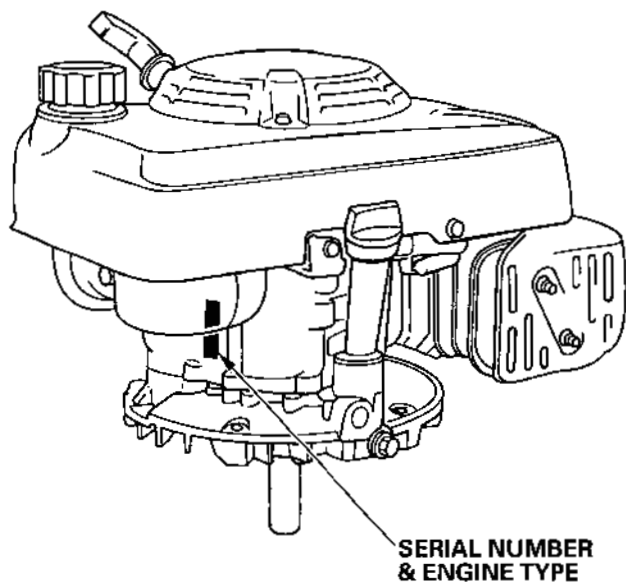

Record the engine serial number in the space below. You will need this serial number when ordering parts, and when making technical or warranty inquiries (see page 49).

Engine serial number: _____

Battery Connections for Electric Starter

Use a 12-volt battery with an ampere-hour rating of at least 8 Ah.

Be careful not to connect the battery in reverse polarity, as this will short circuit the battery charging system. Always connect the positive (+) battery cable to the battery terminal before connecting the negative (-) battery cable, so your tools cannot cause a short circuit if they touch a grounded part while tightening the positive (+) battery cable end.

▲ WARNING

A battery can explode if you do not follow the correct procedure, seriously injuring anyone nearby.

Keep all sparks, open flames, and smoking materials away from the battery.

1. Connect the battery positive (+) cable to the starter solenoid terminal as shown.
2. Connect the battery negative (-) cable to an engine mounting bolt, frame bolt, or other good engine ground connection.
3. Connect the battery positive (+) cable to the battery positive (+) terminal as shown.
4. Connect the battery negative (-) cable to the battery negative (-) terminal as shown.
5. Coat the terminals and cable ends with grease.

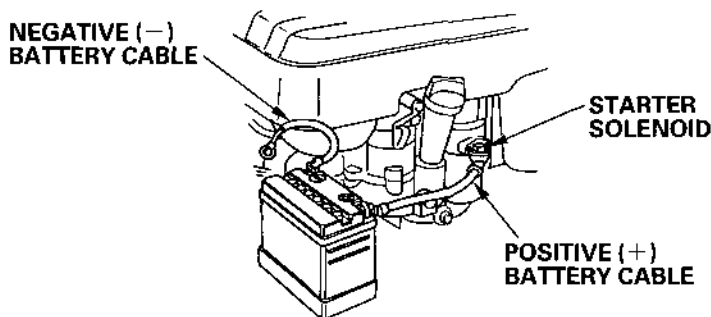

TECHNICAL & CONSUMER INFORMATION

Carburetor Modification for High Altitude Operation

At high altitude, the standard carburetor air-fuel mixture will be too rich. Performance will decrease, and fuel consumption will increase. A very rich mixture will also foul the spark plug and cause hard starting. Operation at an altitude that differs from that at which this engine was certified, for extended periods of time, may increase emissions.

High altitude performance can be improved by specific modifications to the carburetor. If you always operate your engine at altitudes above 5,000 feet (1,500 meters), have your servicing dealer perform this carburetor modification. This engine, when operated at high altitude with the carburetor modifications for high altitude use, will meet each emission standard throughout its useful life.

Even with carburetor modification, engine horsepower will decrease about 3.5% for each 1,000-foot (300-meter) increase in altitude. The effect of altitude on horsepower will be greater than this if no carburetor modification is made.

NOTICE

When the carburetor has been modified for high altitude operation, the air-fuel mixture will be too lean for low altitude use. Operation at altitudes below 5,000 feet (1,500 meters) with a modified carburetor may cause the engine to overheat and result in serious engine damage. For use at low altitudes, have your servicing dealer return the carburetor to original factory specifications.

Oxygenated Fuels

Some conventional gasolines are being blended with alcohol or an ether compound. These gasolines are collectively referred to as oxygenated fuels.

To meet clean air standards, some areas of the United States and Canada use oxygenated fuels to help reduce emissions.

If you use an oxygenated fuel, be sure it is unleaded and meets the minimum octane rating requirement.

Before using an oxygenated fuel, try to confirm the fuel's contents. Some states/provinces require this information to be posted on the pump.

The following are the EPA approved percentages of oxygenates:

ETHANOL ————— (ethyl or grain alcohol) 10% by volume
You may use gasoline containing up to 10% ethanol by volume. Gasoline containing ethanol may be marketed under the name "Gasohol".

MTBE ————— (methyl tertiary butyl ether) 15% by volume
You may use gasoline containing up to 15% MTBE by volume.

METHANOL ————— (methyl or wood alcohol) 5% by volume
You may use gasoline containing up to 5% methanol by volume, as long as it also contains cosolvents and corrosion inhibitors to protect the fuel system. Gasoline containing more than 5% methanol by volume may cause starting and/or performance problems. It may also damage metal, rubber, and plastic parts of your fuel system.

If you notice any undesirable operating symptoms, try another service station, or switch to another brand of gasoline.

Fuel system damage or performance problems resulting from the use of an oxygenated fuel containing more than the percentages of oxygenates mentioned above are not covered under warranty.

TECHNICAL & CONSUMER INFORMATION

Emission Control System Information

Source of Emissions

The combustion process produces carbon monoxide, oxides of nitrogen, and hydrocarbons. Control of hydrocarbons and oxides of nitrogen is very important because, under certain conditions, they react to form photochemical smog when subjected to sunlight. Carbon monoxide does not react in the same way, but it is toxic.

Honda utilizes lean carburetor settings and other systems to reduce the emissions of carbon monoxide, oxides of nitrogen and hydrocarbons.

The U.S. and California Clean Air Acts

EPA and California regulations require all manufacturers to furnish written instructions describing the operation and maintenance of emission control systems.

The following instructions and procedures must be followed in order to keep the emissions from your Honda engine within the emission standards.

Tampering and Altering

Tampering with or altering the emission control system may increase emissions beyond the legal limit. Among those acts that constitute tampering are:

- Removal or alteration of any part of the intake, fuel or exhaust systems.
- Altering or defeating the governor linkage or speed-adjusting mechanism to cause the engine to operate outside its design parameters.

Problems That May Affect Emissions

If you are aware of any of the following symptoms, have your engine inspected and repaired by your servicing dealer.

- Hard starting or stalling after starting.
- Rough idle.
- Misfiring or backfiring under load.
- Afterburning (backfiring).
- Black exhaust smoke or high fuel consumption.

Replacement Parts

The emission control systems on your Honda engine were designed, built, and certified to conform with EPA and California emission regulations. We recommend the use of genuine Honda parts whenever you have maintenance done. These original-design replacement parts are manufactured to the same standards as the original parts, so you can be confident of their performance. The use of replacement parts that are not of the original design and quality may impair the effectiveness of your emission control system.

A manufacturer of an aftermarket part assumes the responsibility that the part will not adversely affect emission performance. The manufacturer or rebuilder of the part must certify that use of the part will not result in a failure of the engine to comply with emission regulations.

Maintenance

Follow the maintenance schedule on page 21. Remember that this schedule is based on the assumption that your machine will be used for its designed purpose. Sustained high-load or high-temperature operation, or use in unusually wet or dusty conditions, will require more frequent service.

TECHNICAL & CONSUMER INFORMATION

Air Index

An Air Index Information hang tag/label is applied to engines certified to an emission durability time period in accordance with the requirements of the California Air Resources Board.

The bar graph is intended to provide you, our customer, the ability to compare the emissions performance of available engines. The lower the Air Index, the less pollution.

The durability description is intended to provide you with information relating to the engine's emission durability period. The descriptive term indicates the useful-life period for the engine's emission control system. See your *Emission Control Warranty* for additional information.

Descriptive Term	Applicable to Emissions Durability Period
Moderate	50 hours (0 – 65 cc) 125 hours (greater than 65 cc)
Intermediate	125 hours (0 – 65 cc) 250 hours (greater than 65 cc)
Extended	300 hours (0 – 65 cc) 500 hours (greater than 65 cc)

The Air Index Information hang tag must remain on the engine until it is sold. Remove the hang tag before operating the engine.

TECHNICAL & CONSUMER INFORMATION

Specifications

Length × Width × Height	14.8 × 14.0 × 13.2 in (375 × 355 × 335 mm)
Dry weight	All2 type: 31.1 lbs (14.1 kg) D12 type: 27.8 lbs (12.6 kg)
Engine type	4-stroke, overhead valve, single cylinder
Displacement [Bore × Stroke]	7.2 cu-in (118 cm ³) [2.4 × 1.7 in (60 × 42 mm)]
Max. output	3.9 hp (4.0 PS) at 3,600 rpm
Max. torque	5.9 lbf-ft (8 N·m, 0.82 kgf·m)
Fuel consumption	0.56 lbs/hph (340 g/kWh, 250 g/PSh)
Cooling system	Forced air
Ignition system	Transistorized magneto
PTO shaft rotation	Counterclockwise

Tuneup

ITEM	SPECIFICATION	MAINTENANCE
Spark plug gap	0.028–0.031 in (0.70–0.80 mm)	Refer to page 30
Valve clearance	IN: 0.15 ± 0.02 mm (cold) EX: 0.20 ± 0.02 mm (cold)	See your authorized Honda dealer
Other specifications	No other adjustments needed	

TECHNICAL & CONSUMER INFORMATION

CONSUMER INFORMATION

Honda Publications

These publications will give you additional information for maintaining and repairing your engine. You may order them from your Honda engine dealer.

Shop Manual

This manual covers complete maintenance and overhaul procedures. It is intended to be used by a skilled technician.

Parts Catalog

This manual provides complete, illustrated parts lists.

Customer Service Information

Serviceing dealership personnel are trained professionals. They should be able to answer any question you may have. If you encounter a problem that your dealer does not solve to your satisfaction, please discuss it with the dealership's management. The Service Manager or General Manager can help. Almost all problems are solved in this way.

If you are dissatisfied with the decision made by the dealership's management, contact the Honda Power Equipment Customer Relations Office. You can write to:

American Honda Motor Co., Inc.
Power Equipment Division
Customer Relations Office
4900 Marconi Drive
Alpharetta, Georgia 30005-8847

Or telephone: (770) 497-6400

When you write or call, please give us this information:

- Model and serial number (see page 40)
- Name of dealer who sold the engine to you
- Name and address of dealer who services your engine
- Date of purchase
- Your name, address and telephone number
- A detailed description of the problem

MEMO

MEMO

MEMO

QUICK REFERENCE INFORMATION

Fuel	Type	Unleaded gasoline with a pump octane rating of 86 or higher (page 23)
	Capacity	0.26 US gal (1.0 ℓ , 0.22 Imp gal)
Engine Oil	Type	SAE 10W-30, API SJ for general use (page 26)
	Capacity	0.63 US qt (0.60 ℓ , 0.53 Imp qt)
Spark Plug	Type	NGK: BP5ES , BPR5ES DENSO: W16EP-U, W16EPR-U
	Gap	0.028 – 0.031 in (0.70 – 0.80 mm) (page 30)
Carburetor	Idle speed	2,000 ± 150 rpm (page 31)
Maintenance	Before each use	Check engine oil level. Check transmission oil level if applicable. Check air filter.
	First 20 hours	Change engine oil. Check transmission oil if applicable.
	Subsequent	Refer to the maintenance schedule on page 21.

HONDA

The Power of Dreams

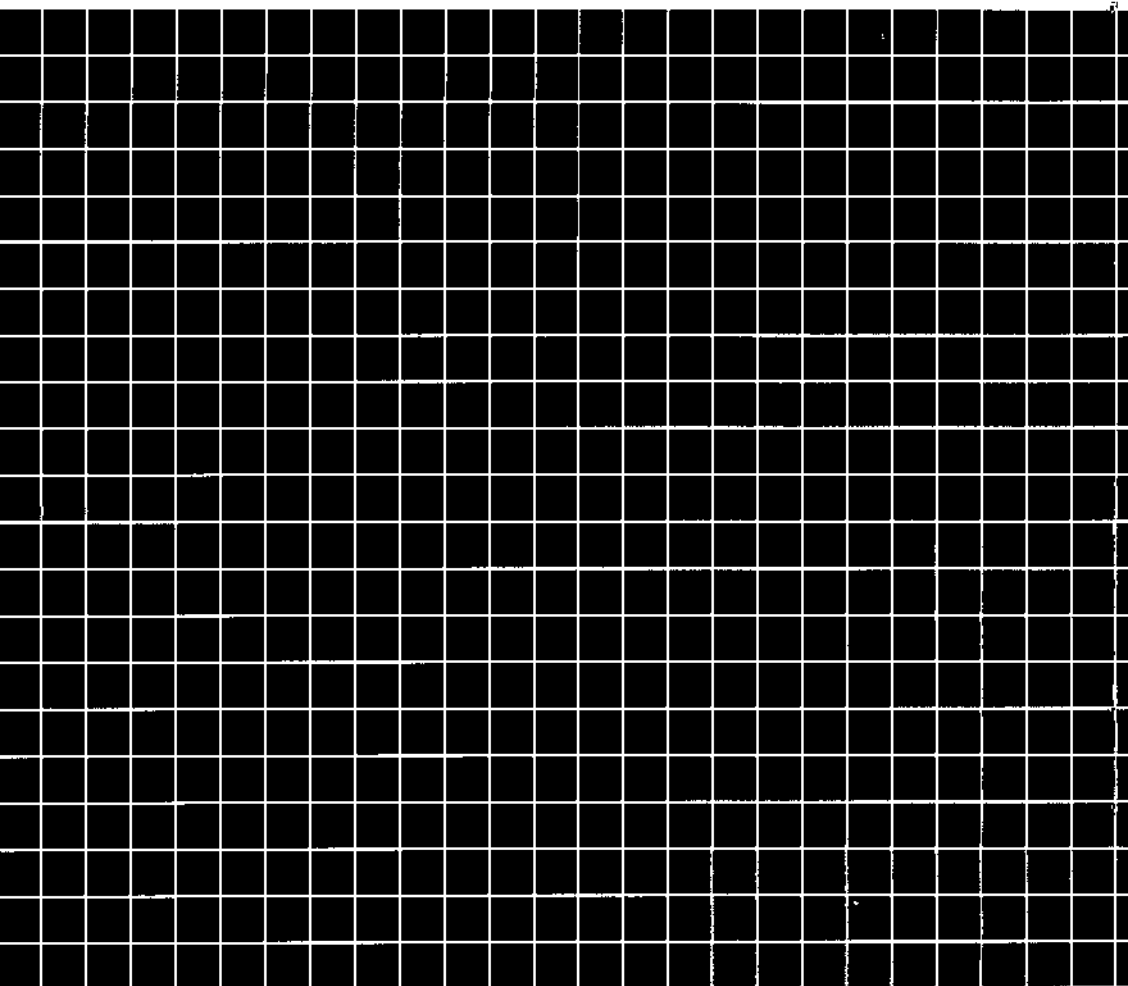

31ZE6701
00X31-ZE6-7010

EM3 (AH) (英) (V) (HC) 300.2001.10
(Hi) Printed in Japan