

HONDA

GC Series Engines

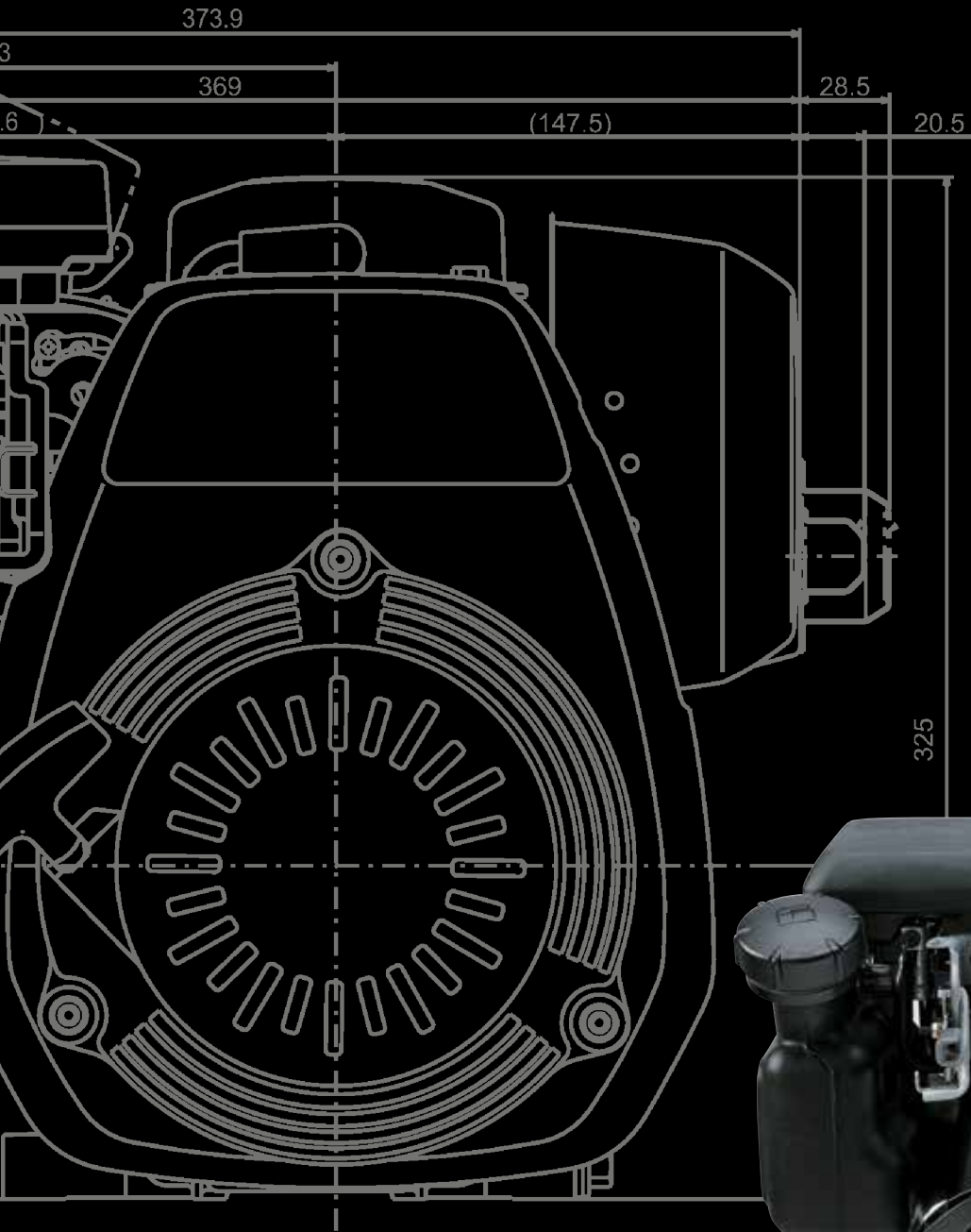

With a GC Series engine at the heart of your home-use power equipment, you'll be in business.

The Honda GC Series offers powerful, versatile functionality that will add great competitive value to any engine-powered product. These compact, lightweight 4-stroke engines were specifically designed for home-use power equipment applications. Featured innovations include the world's first internal timing belt, the superior efficiency and performance of an overhead cam layout and the durability and light weight of uniblock construction. Not to mention the same legendary reliability you've come to expect from the leader in 4-stroke engine technology. Put a Honda GC Series engine to work for you and you'll quickly see why – when it comes to power, we mean business.

The lightest engines in their class

A revolutionary combination of the world's first internal timing belt, a tough nylon overhead cam and uniblock construction has made the GC Series lighter and more compact than any engine in its class. Plus, simple construction has minimized the number of parts, making the engine reliable and easier to operate.



Dramatically improved sound quality

Power equipment users and their neighbors will prefer the quiet operation offered by the GC Series' built-in timing belt. Valvetrain and gear noise have also been minimized for a better quality engine sound that is distinctly easier on the ears – a feature sure to be appreciated by users and bystanders alike.

Consistent, dependable power

The wide, flat, powerful torque offered by Honda's GC Series engines helps reduce engine speed drop associated with sudden load increases for smoother, less-troublesome, all-around performance.

Fast, easy, reliable starting

GC Series engines feature a horizontal cross-flow intake port that smoothes the flow of fuel into the combustion chamber for quick, reliable starts that require no special skills. Automatic mechanical decompression further ensures easy starting.

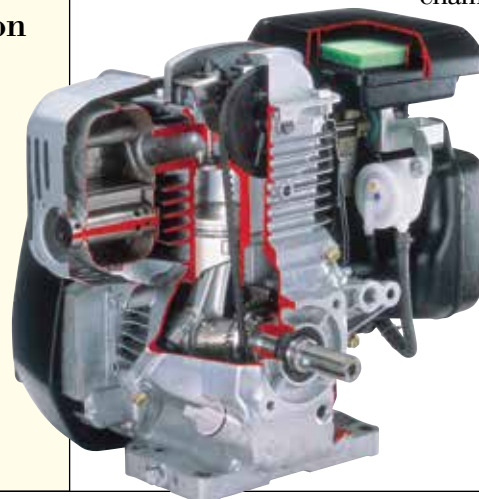

Honda Auto Choke System

This system has been developed for use on GCV160 and GCV190 engines in fixed-throttle lawn mower applications. This user-friendly system is truly automatic, eliminating levers and cables. The engine starts easily whether cold or hot and is ready to use immediately. Once the engine is up and running, the Auto Choke automatically returns to an optimal operating position.



Reduced maintenance and fuel consumption

A truly innovative combination of a compact combustion chamber, overhead cam configuration and unblock construction significantly reduces fuel and oil consumption as compared to conventional side-valve engines. Honda's DuaLube™ System achieves full engine lubrication by combining governor slinger paddles and an oil-delivering timing belt. Also, simple construction reduces many potential maintenance needs, making Honda's GC engine one of the most efficient and cost-effective engines available.

Honda's Compact OHC Layout

Superior efficiency and performance in a smaller package

As the name implies, overhead cam (OHC) engines have their camshafts positioned in the cylinder head above the combustion chamber. Valves are located in the roof of the combustion chamber (instead of at the side) to offer the same combustion-related advantages as OHV engines. The OHC layout builds on these advantages by reducing the number of valvetrain components and allowing them to be lighter and stronger, thereby making the engine more compact and lightweight overall.

Overhead Cam, Internal Timing Belt

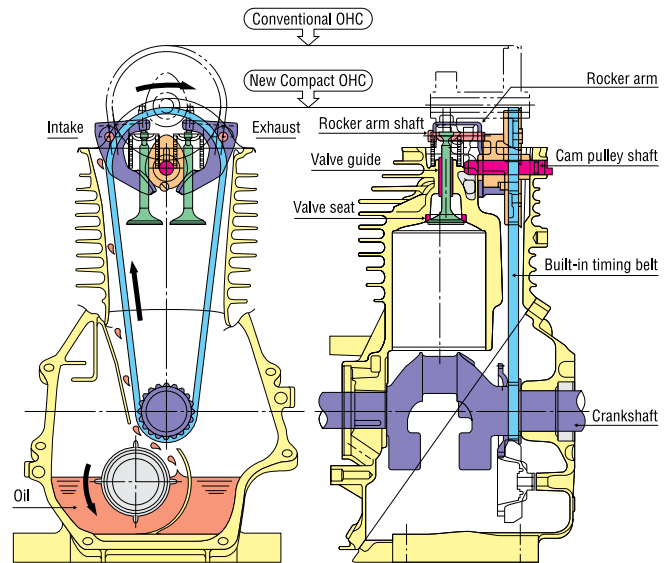

- | | |
|---|-----------------------------------|
| Cam pulley | Cylinder block
Crankcase cover |
| Valves | Built-in timing belt |
| Cam pulley shaft
Valve guide
Valve seat | Rocker arm shafts |
| Crankshaft
Rocker arms | Conventional OHC construction |

Horizontal Shaft

Honda GC Engines provide an ideal source of reliable, lightweight power for a variety of consumer products including pressure washers, pumps, compressors and portable generators.

GC160



Engine Type	Air-cooled, 4-Stroke, OHC, single cylinder
Bore x Stroke	2.5" x 2.0" (64 x 50 mm)
Displacement	9.8 cu in (160 cm ³)
Compression Ratio	8.5 : 1
Net Power (kW/rpm)*	4.6HP (3.4kW) at 3,600 rpm
Net Torque*	6.9 lbs ft (9.4 Nm) at 2,500 rpm
PTO Shaft Rotation	Counterclockwise (from PTO shaft side)
Ignition System	Transistorized Magneto
Starting System	Recoil or Electric Starter
Carburetor	Horizontal type butterfly valve
Lubrication System	Forced Splash
Governor System	Centrifugal Mechanical
Air Cleaner	Dry (paper) type
Oil Capacity	0.61 US qt (0.58 l)
Fuel Tank Capacity (liter)	1.9 US qt (1.8l)
Dimensions (L x W x H)	13.3" (337mm) x 14.5" (369mm) x 13.0" (331mm)
Dry Weight	25.4 lbs (11.5 kg)

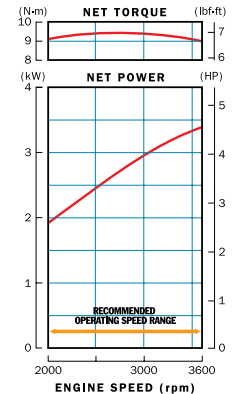

GC190



Engine Type	Air-cooled, 4-Stroke, OHC, single cylinder
Bore x Stroke	2.7" x 2.0" (69 x 50 mm)
Displacement	11.4 cu in (187 cm ³)
Compression Ratio	8.5 : 1
Net Power (kW/rpm)*	5.2HP (3.9kW) at 3,600 rpm
Net Torque*	8.3 lbs ft (11.2 Nm) at 2,500 rpm
PTO Shaft Rotation	Counterclockwise (from PTO shaft side)
Ignition System	Transistorized Magneto
Starting System	Recoil or Electric Starter
Carburetor	Horizontal type butterfly valve
Lubrication System	Forced Splash
Governor System	Centrifugal Mechanical
Air Cleaner	Dry (paper) type
Oil Capacity	0.61 US qt (0.58 l)
Fuel Tank Capacity (liter)	1.9 US qt (1.8l)
Dimensions (L x W x H)	13.6" (345mm) x 14.5" (369mm) x 13.0" (331mm)
Dry Weight	29.1 lbs (13.2 kg)

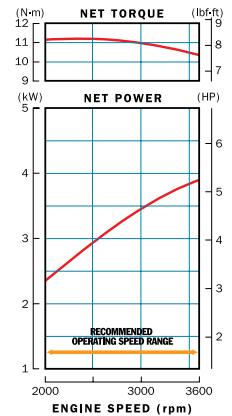

Shaft Types

* The power rating of the engines indicated in this document measures the net power output at 3600 rpm and net torque at 2500 rpm, as tested on a production engine. Mass production engines may vary from this value. Actual power output for the engine installed in the final machine will vary depending on numerous factors, including the operating speed of the engine in application, environmental conditions, maintenance and other variables.

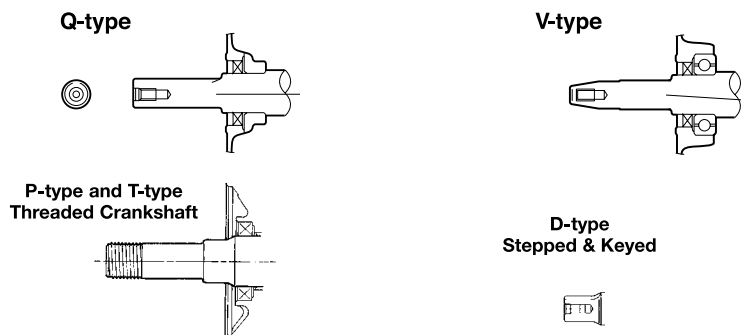

Vertical Shaft

Honda GCV Engines offer lawn mower users (and their neighbors!) a quiet, yet powerful and lightweight combination for a variety of demanding mowing applications. The GCV is also an excellent choice for residential-use pressure washers.

GCV160



Engine Type	Air-cooled, 4-Stroke, OHC, single cylinder
Bore x Stroke	2.5" x 2.0" (64 x 50 mm)
Displacement	9.8 cu in (160 cm ³)
Compression Ratio	8.5 : 1
Net Power (kW/rpm)*	4.4HP (3.3kW) at 3,600 rpm
Net Torque*	6.9 lbs ft (9.4 Nm) at 2,500 rpm
PTO Shaft Rotation	Counterclockwise (from PTO shaft side)
Ignition System	Transistorized Magneto
Starting System	Recoil or Electric Starter
Carburetor	Horizontal type butterfly valve
Lubrication System	Forced Splash
Governor System	Centrifugal Mechanical
Air Cleaner	Dry (paper) type
Oil Capacity	0.58 US qt (0.55 l)
Fuel Tank Capacity (liter)	0.98 US qt (0.93l)
Dimensions (L x W x H)	15.5" (395mm) x 12.8" (327mm) x 13.9" (355mm)
Dry Weight	22.2 lbs (10.1kg)

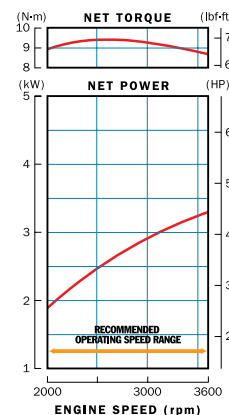

GCV190



Engine Type	Air-cooled, 4-Stroke, OHC, single cylinder
Bore x Stroke	2.7" x 2.0" (69 x 50 mm)
Displacement	11.4 cu in (187 cm ³)
Compression Ratio	8.5 : 1
Net Power (kW/rpm)*	5.1HP (3.8kW) at 3,600 rpm
Net Torque*	8.3 lbs ft (11.3 Nm) at 2,500 rpm
PTO Shaft Rotation	Counterclockwise (from PTO shaft side)
Ignition System	Transistorized Magneto
Starting System	Recoil or Electric Starter
Carburetor	Horizontal type butterfly valve
Lubrication System	Forced Splash
Governor System	Centrifugal Mechanical
Air Cleaner	Dry (paper filter)
Oil Capacity	0.58 US qt (0.55 l)
Fuel Tank Capacity (liter)	0.98 US qt (0.93l)
Dimensions (L x W x H)	15.5" (395mm) x 12.8" (327mm) x 13.9" (355mm)
Dry Weight	27.6 lbs (12.5 kg)

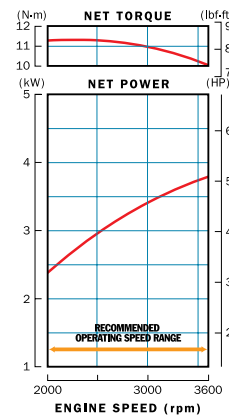

Shaft Types

N1-type

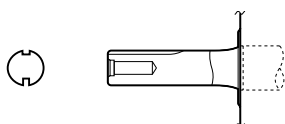

N2-type

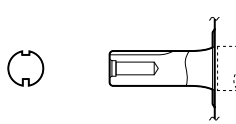

N3-type

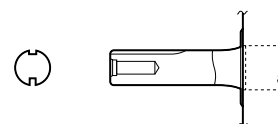

N4-type

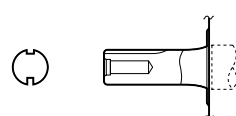

N5-type

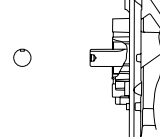

* The power rating of the engines indicated in this document measures the net power output at 3600 rpm and net torque at 2500 rpm, as tested on a production engine. Mass production engines may vary from this value. Actual power output for the engine installed in the final machine will vary depending on numerous factors, including the operating speed of the engine in application, environmental conditions, maintenance and other variables.

Unique Honda blade brake clutch assembly is available as an option for use only on Honda GCV Series engines for lawn mower applications.

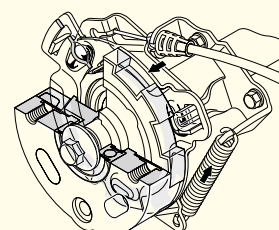

Honda Engine Distributors

ALABAMA

MTA DISTRIBUTORS
SEE TENNESSEE

ALASKA

SCOTSCO, INC.
SEE OREGON

ARIZONA

TRU-POWER, INC.
SEE SOUTHERN CALIFORNIA

ARKANSAS

LIGHTBOURN EQUIPMENT
SEE TEXAS

CALIFORNIA

Northern California
PACE WEST, INC.
www.pacelink.com
5850 Adler Circle
Sacramento, CA 95828
(734) 453-6258
FAX (916) 383-6550
pace@pacelink.com

Southern California
MTA DISTRIBUTORS SEE
TENNESSEE

COLORADO

ANDERSON INDUSTRIAL
ENGINES
SEE NEBRASKA

CONNECTICUT

EASTERN EQUIPMENT, INC.
SEE NEW HAMPSHIRE

DELAWARE

TIDEWATER
SEE VIRGINIA

DISTRICT OF COLUMBIA

TIDEWATER
SEE VIRGINIA

FLORIDA

MTA DISTRIBUTORS
SEE TENNESSEE

GEORGIA

MTA DISTRIBUTORS
SEE TENNESSEE

HAWAII

SCOTSCO, INC.
SEE OREGON

IDAHO

SCOTSCO, INC.
SEE OREGON

ILLINOIS

PACE, INC.
SEE MICHIGAN

INDIANA

PACE, INC.
SEE MICHIGAN

IOWA

IOWA POWER PRODUCTS
www.iowapower.com
522 Brooks Road
Iowa Falls, IA 50126
(641) 648-2507
FAX (641) 648-5013
iowapower@iowapower.com

KANSAS

ANDERSON
INDUSTRIAL ENGINES
www.ai-engines.com
80 S. James Street
Kansas City, KS 66118
(913) 321-7040
Fax (913) 321-7341
info@ai-engines.com

KENTUCKY

MTA DISTRIBUTORS
SEE TENNESSEE

*Northern Kentucky/
Cincinnati area*
HAYWARD DISTRIBUTING
SEE OHIO

LOUISIANA

LIGHTBOURN EQUIPMENT
SEE TEXAS

MAINE

EASTERN EQUIPMENT, INC.
SEE NEW HAMPSHIRE

MARYLAND

TIDEWATER
SEE VIRGINIA

MASSACHUSETTS

EASTERN EQUIPMENT, INC.
SEE NEW HAMPSHIRE

MICHIGAN

PACE, INC.
www.pacelink.com
739 South Mill
Plymouth, MI 48170
(734) 453-6258
FAX (734) 453-5320
pace@pacelink.com

Northern Michigan
ENGINE POWER INC.
SEE WISCONSIN

MINNESOTA

GREAT NORTHERN
EQUIP. DIST.
www.gnedi.com
20195 South Diamond Lake Rd.
Rogers, MN 55374
(763) 428-2237
FAX (763) 428-4821
chrisb@gnedi.com

MISSISSIPPI

MTA DISTRIBUTORS
SEE TENNESSEE

MISSOURI

ANDERSON
INDUSTRIAL ENGINES
SEE KANSAS

MONTANA

SCOTSCO, INC.
SEE OREGON

NEBRASKA

ANDERSON
INDUSTRIAL ENGINES
www.ai-engines.com
13423 Lynam Drive
Omaha, NE 68138
(402) 558-8700
FAX (402) 558-8249
info@ai-engines.com

NEVADA

PACE WEST, INC.
SEE NORTHERN CALIFORNIA

TRU-POWER, INC.
SEE SOUTHERN CALIFORNIA

NEW HAMPSHIRE

EASTERN EQUIPMENT, INC.
www.easternequipmentinc.com
6 "B" Street
Derry, NH 03038
(603) 437-0407
FAX (603) 437-0815
gmiscoeastern@aol.com

NEW JERSEY

TIDEWATER
SEE VIRGINIA

NEW MEXICO

LIGHTBOURN EQUIPMENT
SEE TEXAS

NEW YORK

EASTERN EQUIPMENT, INC.
SEE NEW HAMPSHIRE

NORTH CAROLINA

TIDEWATER
SEE VIRGINIA

NORTH DAKOTA

GREAT NORTHERN
EQUIPMENT
SEE MINNESOTA

OHIO

HAYWARD DISTRIBUTING
www.haydist.com
4061 Perimeter Drive
Columbus, OH 43228
(614) 272-5953
FAX (614) 272-5959
mbudde@haydist.com

North Western Ohio

PACE, INC.
SEE MICHIGAN

OKLAHOMA

LIGHTBOURN EQUIPMENT
SEE TEXAS

OREGON

SCOTSCO, INC.
www.scotsco.com
16750 SE Kens Ct.
Milwaukie, OR 97267
(503) 653-7791
FAX (503) 653-7838
tfrandsen@scotsco.com

PENNSYLVANIA

HAYWARD DISTRIBUTING
SEE OHIO

RHODE ISLAND

EASTERN EQUIPMENT, INC.
SEE NEW HAMPSHIRE

SOUTH CAROLINA

TIDEWATER
SEE VIRGINIA

SOUTH DAKOTA

GREAT NORTHERN
EQUIPMENT
SEE MINNESOTA

TENNESSEE

MTA DISTRIBUTORS
www.mtadistributors.com
555 Hickory Hills Blvd.
Whites Creek, TN 37189-9244
(615) 299-8777
FAX (615) 299-0464
customerservice
@mtadistributors.com

TEXAS

LIGHTBOURN EQUIPMENT
www.lightbourneequipment.com
13655 Welch Road
Dallas, TX 75244
(972) 233-5151
FAX (972) 661-0738
sales@lightbourneequipment.com

UTAH

PACE WEST, INC.
SEE NORTHERN CALIFORNIA

VERMONT

EASTERN EQUIPMENT, INC.
SEE NEW HAMPSHIRE

VIRGINIA

TIDEWATER POWER
EQUIP. CO.
www.tpeco.com
3760 East Virginia Beach Blvd.
Norfolk, VA 23502
(757) 464-1755
FAX (800) 288-8953
info@tpeco.com

WASHINGTON

SCOTSCO, INC.
SEE OREGON

WEST VIRGINIA

HAYWARD DISTRIBUTING
SEE OHIO

WISCONSIN

ENGINE POWER, INC.
www.enginepower.com
1830 Executive Drive
Oconomowoc, WI 53066
(262) 567-8575
FAX (262) 567-2556
postoff@enginepower.com

WYOMING

ANDERSON
INDUSTRIAL ENGINES
SEE NEBRASKA

Honda. The largest manufacturer of gasoline engines in the world.



GC SERIES



GS SERIES



GX SERIES



iGX SERIES



V-TWIN SERIES



MINI 4-STROKE SERIES



iGX V-TWIN SERIES

HONDA

Visit us at engines.honda.com

For optimum performance and safety we recommend you read the owner's manual before operating your Honda Power Equipment. Specifications subject to change without notice.

All images contained herein are either owned by American Honda Motor Co., Inc., or used under a valid license. It is a violation of federal law to reproduce these images without express written permission from American Honda Motor Co., Inc., or the individual copyright owner of such images. All rights reserved. Honda, the Honda Engines logo, Honda engine model names and their trade dress are trademarks of Honda Motor Co., Ltd. used under license from American Honda Motor Co., Inc. Many Honda engine and vehicle model names, and associated trade dress may be seen at www.honda.com. ©2015-2019 American Honda Motor Co., Inc.

