

Water Pump Replacement for BF75D•BF90D Outboard Motors

Prior to removing the gear case, make sure the outboard motor is secure on an engine stand or transom of a boat that is out of the water. Tilt the outboard motor up to the highest position and place the shift lever in the "N" (neutral) position.

With a 10 mm wrench, remove the 6 x 16 mm socket bolt and gear case cover to gain access to the 10 x 80 mm bolt.

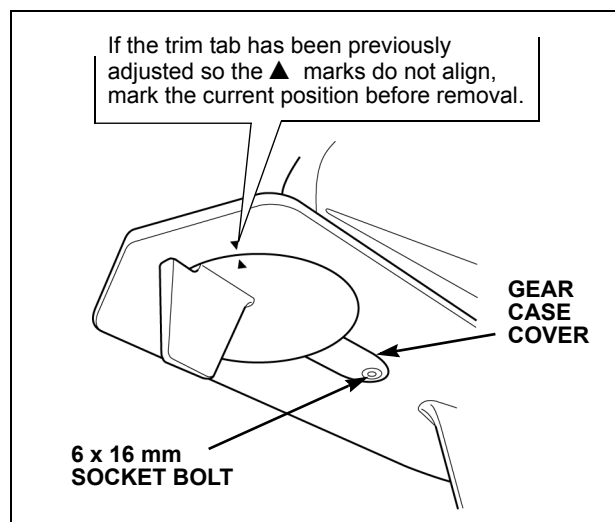

Remove the 10 x 80 mm bolt and washer, four 10 x 40 mm bolts and washers, and remove the gear case assembly. The vertical shaft will stay connected to the gear case, so remove the gear case without twisting, and then place the unit on a workbench.

With a 12 mm wrench, remove the four water pump 8 x 55 mm bolts and washers.

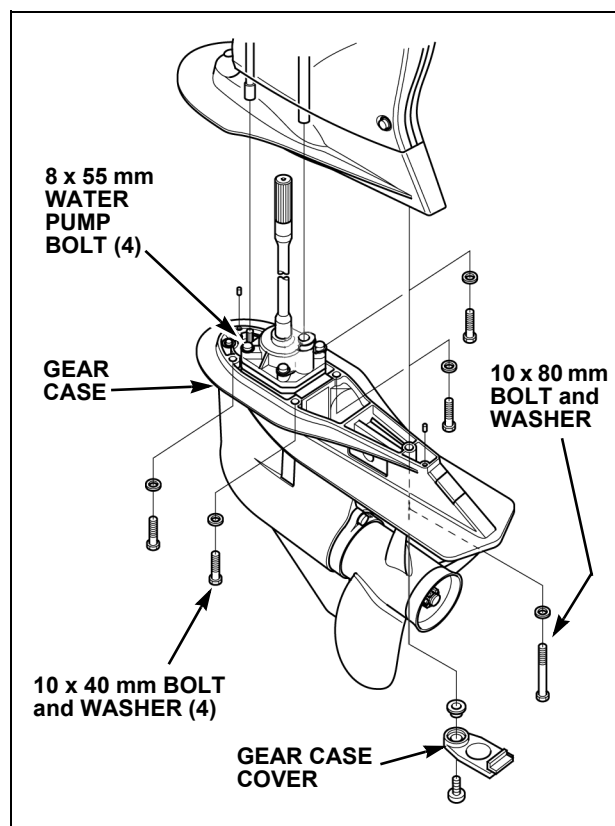

Clean all parts and check the impeller, liner, and cover for wear or cracks.

TYPE KIT	CONTENTS	PART NUMBER
Service kit	Impeller, Gasket, Woodruff key, O-Ring	06192-ZW1-000
Rebuild kit	1- Seal ring 2- Bolt (4) 3- Washer (4) 4- Collar (4) 5- Housing 6- O-Ring 7- Liner 8- Impeller 9- Woodruff key 10- Cover 11- Gasket 12- Gasket	06193-ZZ0-000

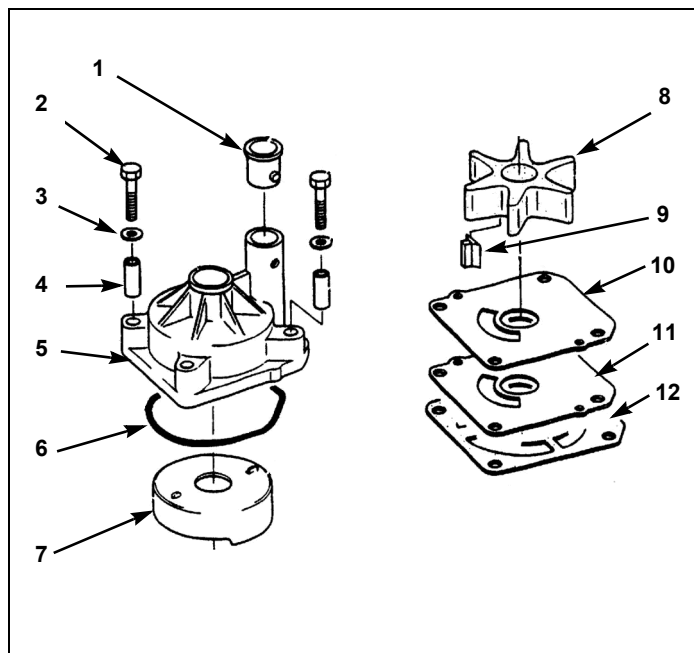

Start reassembling the pump by applying marine grease to the inner surface of the impeller liner, housing O-ring, and the water tube seal rubber.

Install the impeller by turning it counterclockwise into the impeller liner. Make sure the open end of the keyway is visible and will face out when installed in the pump.

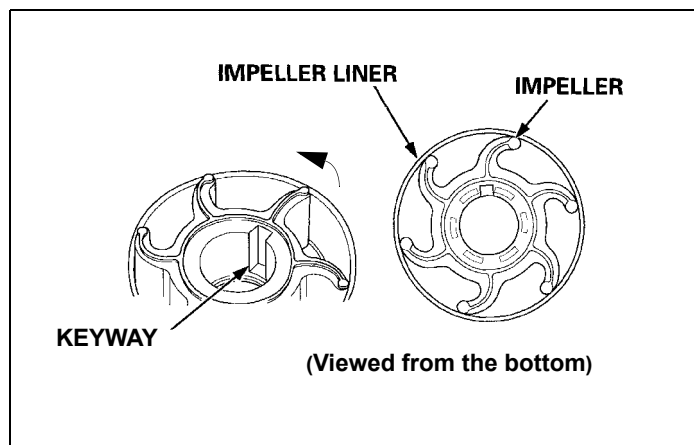

Insert a new greased O-ring and water tube seal rubber and four distance collars into the impeller housing. Install the pump liner/impeller into the housing.

Slide the pump gasket and cover over the shaft, aligning the holes with the pump base.

Place a small amount of marine grease on the Woodruff key and insert it onto the flat surface of the vertical shaft.

Slide the impeller housing assembly over the shaft, making sure to align the Woodruff key with the impeller keyway.

Install the 8 x 55 mm bolts, water tube seal holder, and two washers and torque to **15 ft•lb (20 N•m)** in a crisscross pattern to make sure the housing seats correctly.

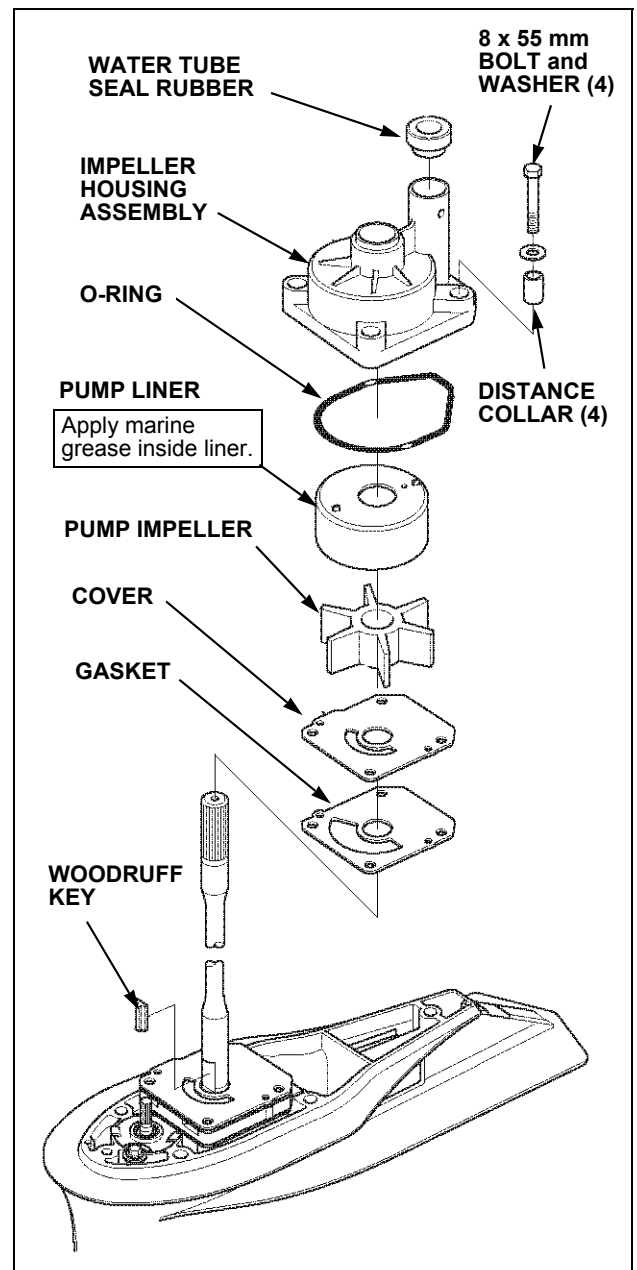

Check that the shift rod in the gear case is in the "N" (Neutral) position. The cutout in the shift rod spline will be in the forward direction as shown.

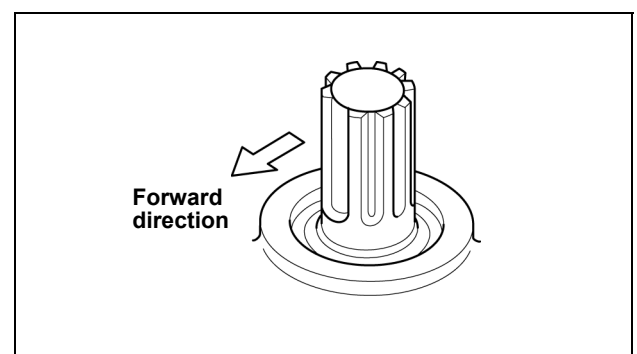

Apply marine grease to the water tube seal ring, vertical shaft splines, and two dowel pins.

Install the gear case assembly into the motor. Start threading the 10 x 80 mm and four 10 x 40 mm bolts and washers to hold the gear case in place.

Torque the five 10 mm gear case bolts to **25 ft•lb (34 N•m)**.

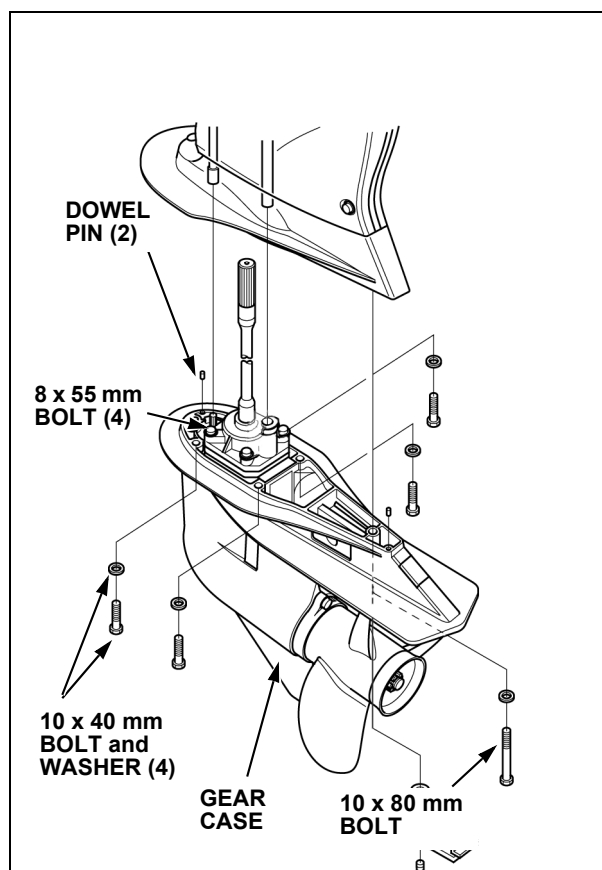

Install the trim tab by aligning the “▲”marks on the trim tab and gear case assembly (or marks previously made). Install the gear case cover and tighten the 6 mm socket bolt.

