

# WIRING DIAGRAM

EG4000CL

# WIRING DIAGRAM

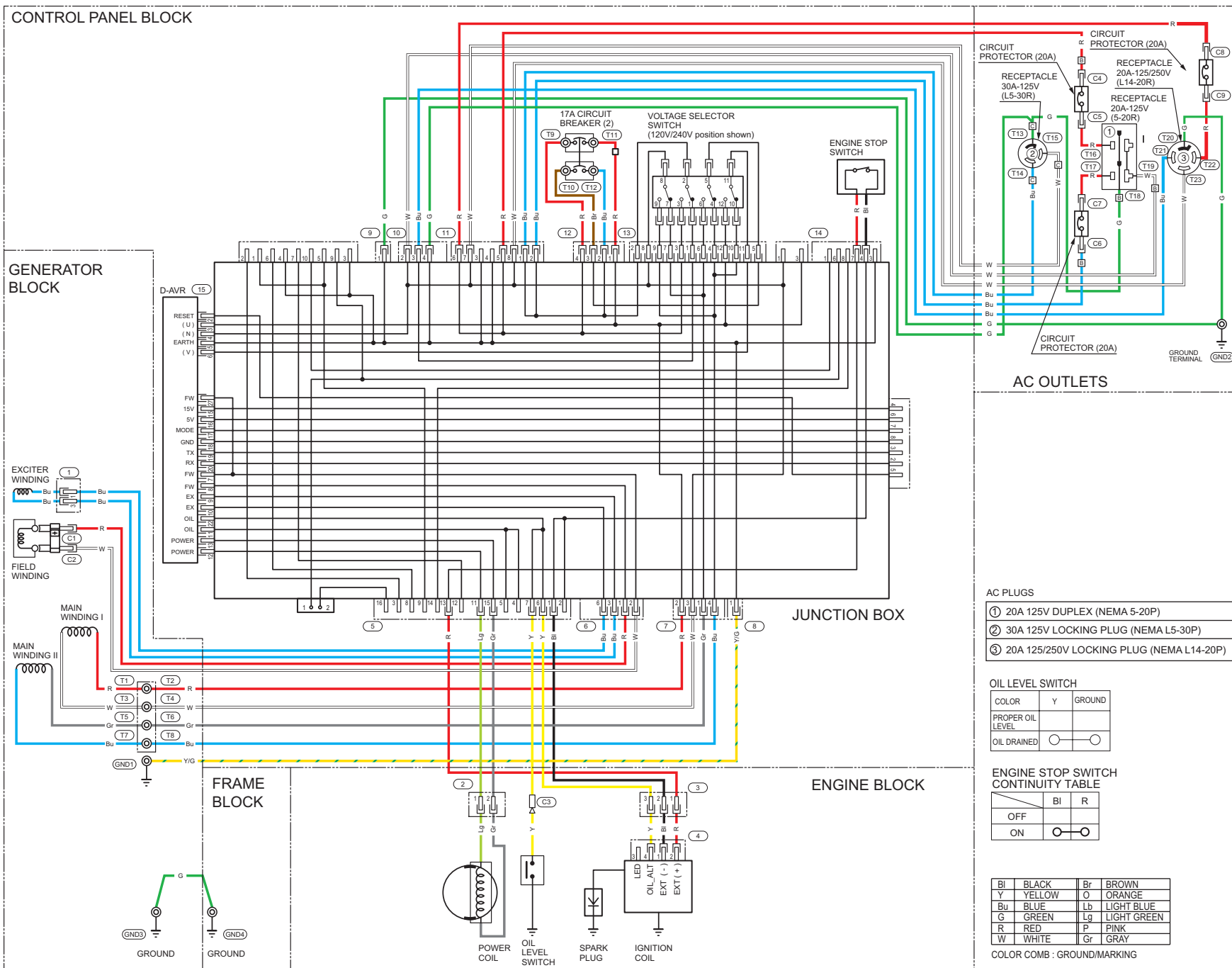

**AC PLUGS**

①	20A 125V DUPLEX (NEMA 5-20P)
②	30A 125V LOCKING PLUG (NEMA L5-30P)
③	20A 125/250V LOCKING PLUG (NEMA L14-20P)

**OIL LEVEL SWITCH**

COLOR	Y	GROUND
PROPER OIL LEVEL	<input type="checkbox"/>	<input type="checkbox"/>
OIL DRAINED	<input type="checkbox"/>	<input type="checkbox"/>

**ENGINE STOP SWITCH CONTINUITY TABLE**

	Bl	R
OFF	<input type="checkbox"/>	<input type="checkbox"/>
ON	<input type="checkbox"/>	<input type="checkbox"/>

Bl	BLACK	Br	BROWN
Y	YELLOW	O	ORANGE
Bu	BLUE	Lb	LIGHT BLUE
G	GREEN	Lg	LIGHT GREEN
R	RED	P	PINK
W	WHITE	Gr	GRAY

COLOR COMB : GROUND/MARKING

CONTROL PANEL BLOCK

GENERATOR BLOCK

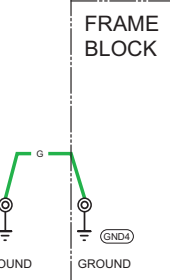
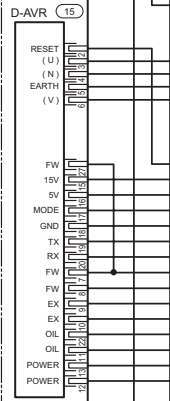
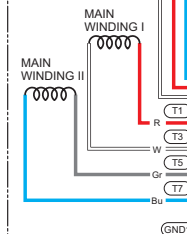
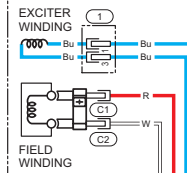

CIRCUIT BREAKER  
21A EG5000CL (2)  
27A EG6500CL (2)

VOLTAGE SELECTOR SWITCH  
(120V/240V position shown)

ENGINE STOP SWITCH

JUNCTION BOX

ENGINE BLOCK

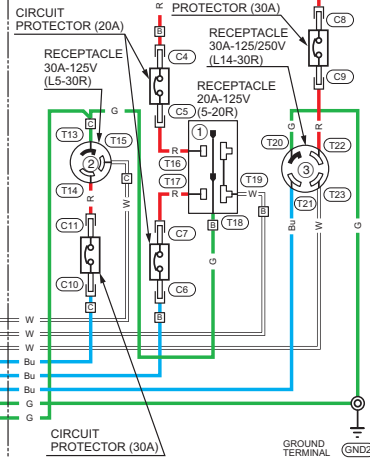
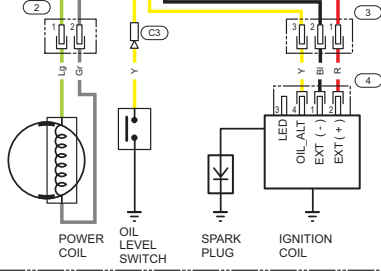

- AC PLUGS
- ① 20A 125V DUPLEX (NEMA 5-20P)
  - ② 30A 125V LOCKING PLUG (NEMA L5-30P)
  - ③ 30A 125/250V LOCKING PLUG (NEMA L14-30P)

OIL LEVEL SWITCH

COLOR	Y	GROUND
PROPER OIL LEVEL	<input type="checkbox"/>	<input type="checkbox"/>
OIL DRAINED	<input type="checkbox"/>	<input type="checkbox"/>

ENGINE STOP SWITCH CONTINUITY TABLE

	BI	R
OFF	<input type="checkbox"/>	<input type="checkbox"/>
ON	<input type="checkbox"/>	<input type="checkbox"/>

COLOR COMB : GROUND/MARKING

BI	BLACK	Br	BROWN
Y	YELLOW	O	ORANGE
Bu	BLUE	Lb	LIGHT BLUE
G	GREEN	Lg	LIGHT GREEN
R	RED	P	PINK
W	WHITE	Gr	GRAY

No part of this publication may be reproduced, stored in a retrieval system, or transmitted, in any form by any means, without prior permission of American Honda Motor Co., Inc.