

HONDA

Power

Equipment

Owner's Manual

GENERATOR

EV4010•EV6010

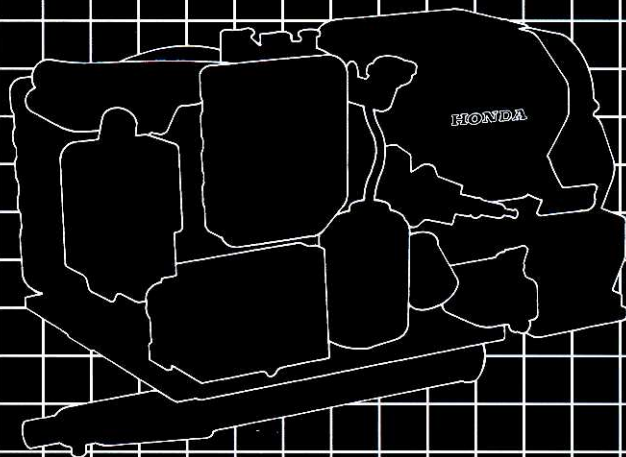



WARNING:



The engine exhaust from this product contains chemicals known to the State of California to cause cancer, birth defects or other reproductive harm.

WARNING

Exhaust contains poisonous carbon monoxide gas that can build up to dangerous levels in closed areas. Breathing carbon monoxide can cause unconsciousness or death.

Never run the generator in a closed or even partially closed area where people may be present.

WARNING

The generator is a potential source of electrical shock if misused. Do not expose the generator to moisture, rain or snow. Do not let the generator get wet, and do not operate it with wet hands.

Keep this owner's manual handy, so you can refer to it at any time. This owner's manual is considered a permanent part of the generator and should remain with the generator if resold.

The information and specifications included in this publication were in effect at the time of approval for printing. Honda Motor Co., Ltd. reserves the right, however, to discontinue or change specifications or design at any time without notice and without incurring any obligation whatever. No part of this publication may be reproduced without written permission.

INTRODUCTION

Congratulations on your selection of a Honda generator. We are certain you will be pleased with your purchase of one of the finest generators on the market.

We want to help you get the best results from your new generator and to operate it safely. This manual contains the information on how to do that; please read it carefully.

As you read this manual, you will find information preceded by a **NOTICE** symbol. That information is intended to help you avoid damage to your generator, other property, or the environment.

We suggest you read the warranty policy to fully understand its coverage and your responsibilities of ownership. The warranty policy is a separate document that should have been given to you by your dealer.

When your generator needs scheduled maintenance, keep in mind that your Honda servicing dealer is specially trained in servicing Honda generators. Your authorized Honda servicing dealer is dedicated to your satisfaction and will be pleased to answer your questions and concerns.

Best Wishes,
Honda Motor Co., Ltd.

A FEW WORDS ABOUT SAFETY

Your safety and the safety of others are very important. And using this generator safely is an important responsibility.

To help you make informed decisions about safety, we have provided operating procedures and other information on labels and in this manual. This information alerts you to potential hazards that could hurt you or others.

Of course, it is not practical or possible to warn you about all the hazards associated with operating or maintaining a generator. You must use your own good judgment.

You will find important safety information in a variety of forms, including:

- **Safety Labels.** — on the generator.
- **Safety Messages** — preceded by a safety alert symbol  and one of three signal words, DANGER, WARNING, or CAUTION.

These signal words mean:

 **DANGER**

You **WILL** be **KILLED** or **SERIOUSLY HURT** if you don't follow instructions.

 **WARNING**

You **CAN** be **KILLED** or **SERIOUSLY HURT** if you don't follow instructions.

 **CAUTION**

You **CAN** be **HURT** if you don't follow instructions.

- **Safety Headings** – such as *IMPORTANT SAFETY INFORMATION*.
- **Safety Chapter** – such as *GENERATOR SAFETY*.
- **Instructions** — how to use this generator correctly and safely.

This entire book is filled with important safety information — please read it carefully.

CONTENTS

GENERATOR SAFETY	4
Safety Label Locations	4
Important Safety Information	5
GENERATOR INSTALLATION AND CONNECTIONS	7
Connections for a Recreational Vehicle	7
Connections to a Building's Electrical System	8
COMPONENT IDENTIFICATION	9
Control Box	10
Remote Control Panel (optional part)	11
PRE-OPERATION CHECK	12
Engine Oil	12
Fuel	13
Air Cleaner	14
Coolant	15
Exhaust System	17
STARTING AND STOPPING THE ENGINE	18
GENERATOR USE	20
Appliance Operation	20
Engine Protection System	21
Circuit Breakers and Fuses	22
Carburetor Modification for High Altitude Operation	23
MAINTENANCE	24
The Importance of Maintenance	24
Maintenance Safety	25
Emission Control System Information	26
Maintenance Schedule	28
Maintenance Record	29
Engine Oil Change	30
Air Cleaner Service	31
Spark Plug Service	32
Spark Arrester Service	34
STORAGE	35
TROUBLESHOOTING	36
WIRING DIAGRAMS	37
SPECIFICATIONS	39
CUSTOMER SERVICE INFORMATION	41

GENERATOR SAFETY

SAFETY LABEL LOCATIONS

Read all safety instructions before operating the generator.

SERVICE INSTRUCTION		HOUR INTERVAL	ENTRETIEN (INSTRUCTION)		NOMBRE D'HEURES
• OIL (1.4 l)	[CHECK] DAILY	[CHANGE] 200	• HUILE (2.5 chopine imp)	[VERIFIER] JOURNELLEMENT	[CHANGER] 200
• FUEL FILTER		[REPLACE] 300	• FILTER A ESSENCE		[REPLACER] 300
• OIL FILTER		[REPLACE] 300	• FILTER A HUILE		[REPLACER] 200
• SPARK PLUG (BPR4HS) 14mm GAP	[CHECK] DAILY	[CHECK] 200	• BOUGIE (BPR4HS) 14mm	[VERIFIER] JOURNELLEMENT	[VERIFIER] 200
• COOLANT	[CHECK] DAILY	[CHANGE] 300	• REFRIGERANT	[VERIFIER] JOURNELLEMENT	[CHANGER] 300
• AIR CLEANER ELEMENT	[CHECK] 100	[REPLACE] 200	• FILTREUR A AIR	[VERIFIER] 100	[REPLACER] 200

WARNING AVERTISSEMENT

TO PREVENT FIRE HAZARD USE ONLY GENUINE Honda AIR CLEANER ELEMENT (Part No. 17211-ZB6) FOR REPLACEMENT. POUR EVITER LES RISQUES D'INCENDIES REMPLACER LES CARTOUCHES DE FILTER A AIR SEULEMENT PAR L'ORIGINAL Honda.

CAUTION EVC610

• MINIMUM INSTALLATION CLEARANCES:
 FRONT: 33 mm (1.3 in)
 REAR: 30 mm (1.2 in)
 TOP: 26 mm (1.02 in)
 ENGINE SIDE: 30 mm (1.2 in)
 GENERATOR SIDE: 34 mm (1.34 in)

• COMPARTMENT DOOR VENTILATION OPENING: MIN. 545 cm² (84.5 in²)

• COMPLETELY SEAL THE COMPARTMENT TO PREVENT VAPORS FROM ENTERING LIVING SPACE.

ATTENTION

• ESPACE MINIMUM A L'INSTALLATION:
 AVANT: 33 mm
 ARRIERE: 30 mm
 DESSUS: 26 mm
 COTE MOTEUR: 30 mm
 COTE GENERATRICE: 34 mm

• OUVERTURE DE L'ENTREE D'AIR DU COMPARTIMENT: MIN. 545 cm²

• LE COMPARTIMENT DOIT ETRE ETANCHE AFIN D'EVITER L'ENTREE DE VAPEURS DANS L'HABITACLE.

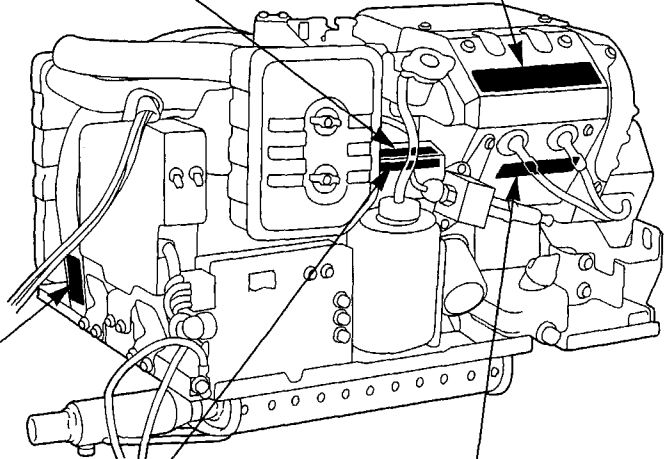

WARNING AVERTISSEMENT

THIS GENERATOR CAN RADIATE ENOUGH HEAT TO IGNITE SOME MATERIALS. THIS GENERATOR MUST BE INSTALLED IN A NON-COMBUSTIBLE ENCLOSURE ONLY. CETTE GENERATRICE DEGAGE UNE CHALEUR SUFFISANTE POUR ENFLAMMER CERTAINS MATERIAUX. CETTE GENERATRICE DOIT ETRE INSTALLEE DANS UNE ENCEINTE A L'EPREUVE DU FEU SEULEMENT.

WARNING AVERTISSEMENT

CONNECTION TO A BUILDING'S ELECTRICAL SYSTEM WITHOUT AN ISOLATION SWITCH MAY RESULT IN ELECTROCUTION OR PROPERTY DAMAGE. CONSULT A LICENSED ELECTRICIAN FOR SWITCH INSTALLATION.

LA CONNEXION AU SYSTEME ELECTRIQUE D'UN BATIMENT SANS COMMUTATEUR D'ISOLATION PEUT RESULTER EN UNE ELECTROCUTION OU DES DOMMAGES MATERIELS. CONSULTER ELECTRICIEN QUALIFIE POUR L'INSTALLATION DU COMMUTATEUR.

READ ALL INSTRUCTIONS IN THE OWNER'S MANUAL BEFORE OPERATING THE PRODUCT.

LIRE TOUTES LES INSTRUCTIONS DANS LE MANUEL DU CONDUCTEUR AVANT D'UTILISER CE PRODUIT.

IMPORTANT SAFETY INFORMATION

Honda generators are designed to give safe and dependable service if operated according to instructions. Read and understand this owner's manual before operating your generator. You can help prevent accidents by being familiar with your generator's controls, and by observing safe operating procedures.

Operator Responsibility

- Know how to stop the generator quickly in case of emergency.
- Understand the use of all generator controls, output receptacles, and connections.
- Be sure that anyone who operates the generator receives proper instruction. Do not let children operate the generator without parental supervision.

Carbon Monoxide Hazards

- **Exhaust contains poisonous carbon monoxide, a colorless and odorless gas. Breathing carbon monoxide can cause loss of consciousness and may lead to death.**
- **Select a parking area that has enough ventilation for safe generator operation. If you run the generator in an area that is confined, or even partially enclosed, the air you breathe will contain a dangerous amount of exhaust gas.**
- **Never run the generator inside a garage or near open windows or doors.**
- **When parking, be careful that the exhaust is not directed into an area that you or your neighbors will use as working space. Avoid the exhaust area when the generator is running.**
- **Provide enough ventilation to keep exhaust gas from building up. Placing awnings or other objects in the exhaust area will restrict ventilation; this may cause exhaust gas to build up and enter working areas.**

Electric Shock Hazards

- **The generator produces enough electric power to cause a serious shock or electrocution if misused.**
- **Do not connect to a building's electrical system unless an isolation switch has been installed by a qualified electrician.**

Fire and Burn Hazards

- **Improper generator installation or wiring connections can cause a fire. Installation should be done only by an authorized Honda generator dealer or other qualified generator installer.**
- **The exhaust system gets hot enough to ignite some materials. Make sure flammable materials such as vegetation, paper and wood products, and chemicals are kept clear of the exhaust system.**
- **Touching a hot engine or exhaust system can cause serious burns. Let the engine cool before performing maintenance.**
- **Gasoline is extremely flammable, and gasoline vapor can explode. Keep flames and sparks away, and do not smoke in the area.**
- **Coolant contains ethylene glycol, which is flammable. When ignited, it has an invisible flame that can cause severe burns. Use care when handling coolant.**

GENERATOR INSTALLATION AND CONNECTIONS

CONNECTIONS FOR A RECREATIONAL VEHICLE

⚠ WARNING Incorrect generator installation or connection can cause electrocution or fire. The generator must be installed and connected as described in the Honda EV4010/EV6010 Generator Installation Manual.

The EV4010/EV6010 generator should be installed by an authorized Honda RV generator dealer or other qualified RV generator installer. Installation must comply with the standards and codes of the following organizations:

U.S.A.: Recreational Vehicle Industry Association (RVIA)
National Fire Protection Association (NFPA)
National Electric Code (NEC)

For protection against electrical shock, all receptacles connected to the generator must be protected by ground-fault circuit interrupters. All individual circuits must be provided with circuit breakers or fuses for protection against circuit overload.

If the RV is equipped to use an outside AC power source, the generator output wires must be completely isolated when the outside AC power source is connected. Refer to the RV owner's manual for information about using an outside AC power source.

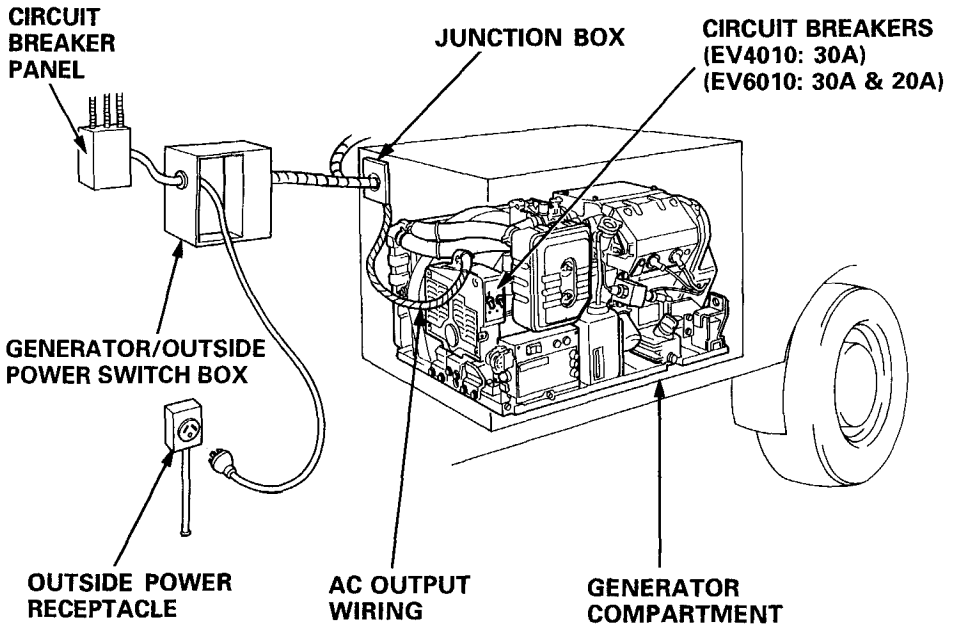

CONNECTIONS TO A BUILDING'S ELECTRICAL SYSTEM

Although the Honda EV4010/EV6010 generator is designed for vehicle use, it can also supply power to a building's electrical system. If the generator will be used as an alternative to utility company power, an isolation switch must be installed to disconnect the utility lines from the building when the generator is connected. Installation must be performed by a qualified electrician and must comply with all applicable laws and electrical codes.

⚠ WARNING

Improper connections to a building's electrical system can allow electric current from the generator to backfeed into utility lines and may cause serious injury or death to utility company workers or others who contact the lines during a power outage. Consult the utility company or a qualified electrician.

NOTICE

Improper connections to a building's electrical system can allow electric current from the utility company to backfeed into the generator, which will severely damage the generator and may cause fires.

In some areas, generators are required by law to be registered with local utility companies. Check local regulations for proper registration and use procedures.

COMPONENT IDENTIFICATION

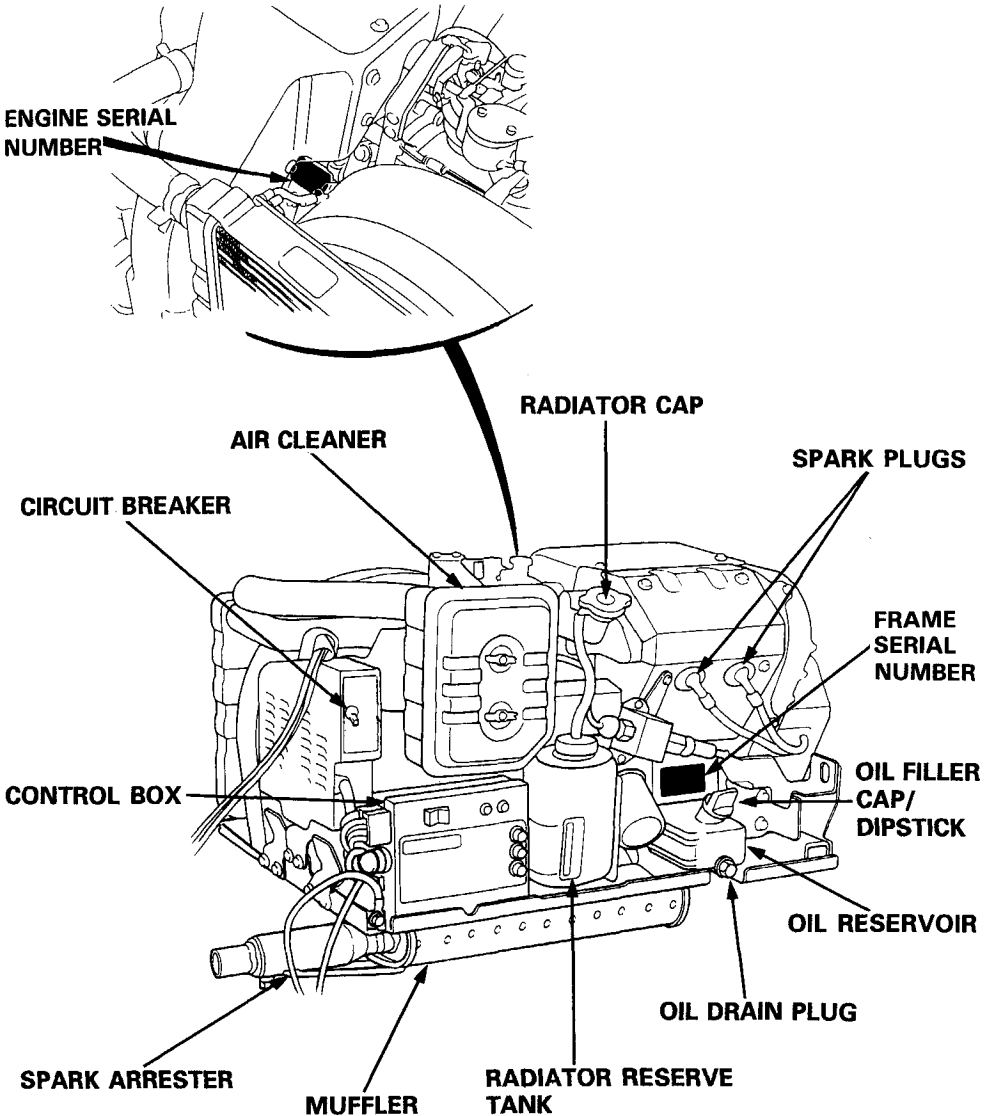

- Record the engine and frame serial numbers and date of purchase for your future reference. Refer to these serial numbers when ordering parts, and when making technical or warranty inquiries (see page 42).

Frame serial number: _____
Engine serial number: _____
Date of purchase: _____

CONTROL BOX

Circuit breaker:

Switch ON for AC power. The breaker will automatically switch OFF if the circuit is more than 20% overloaded.

Pilot lamp:

Lights when the engine is running and goes off when the engine is stopped.

Temperature warning lamp:

Lights when the engine or coolant temperature exceeds the safe operating limit.

Battery terminal:

Connect the battery positive (+) cable here.

Ground terminal:

Connect the battery negative (-) cable here.

Engine switch:

Starts and stops the generator engine.

Fuse holders:

F1: 15 Amp fuse; F2: 4 Amp fuse; F3: 4 Amp fuse.

Remote control coupler:

The remote control panel coupler is connected here.

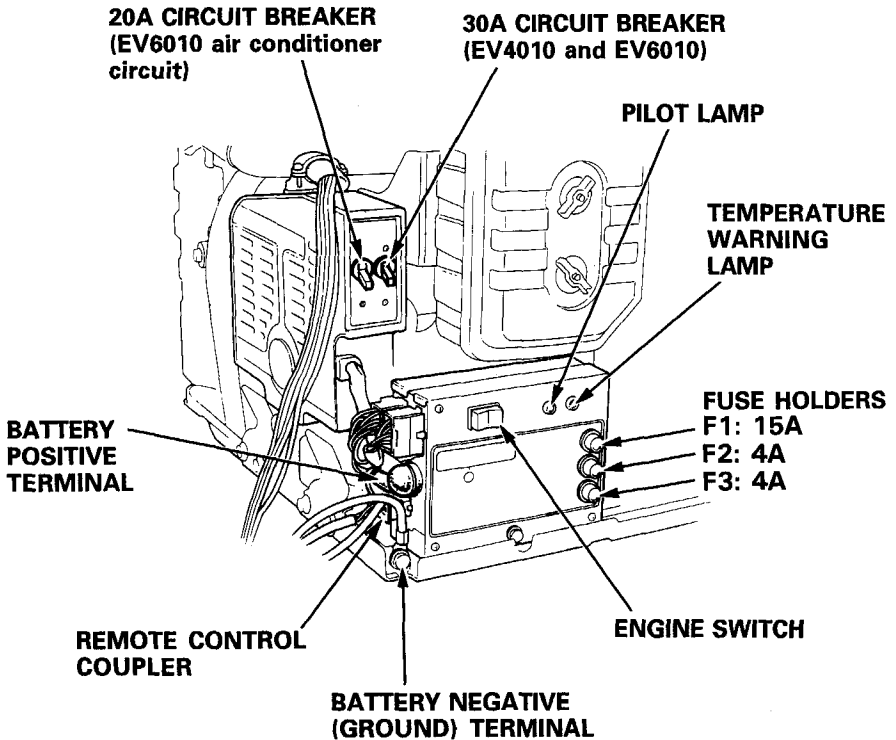

REMOTE CONTROL PANEL (optional part)

- Engine switch:** Starts and stops the generator.
- Pilot lamp:** Comes on when the engine is running and goes off when the engine is stopped.
- Hour meter:** The numbers on the hour meter indicate the total hours operated. This is your guide for determining when maintenance is due.

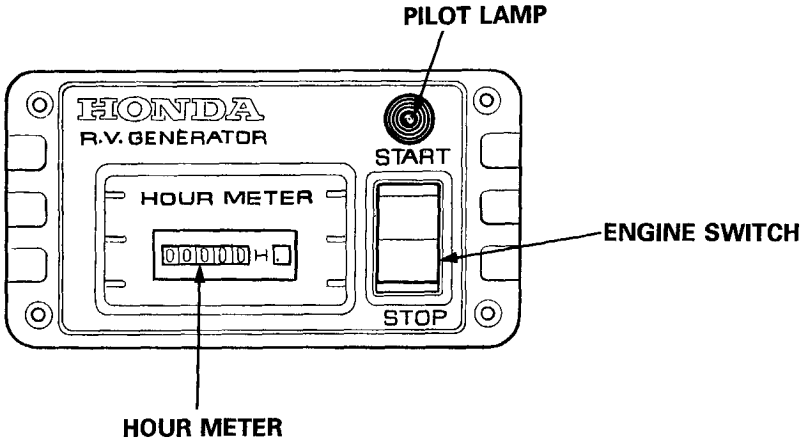

PRE-OPERATION CHECK

IS YOUR GENERATOR READY TO GO?

ENGINE OIL

Before you start the generator, check the engine oil level while parked on a level surface and the generator engine stopped.

Use 4-stroke motor oil that meets or exceeds the requirements for API service category SJ or later. Always check the API SERVICE label on the oil container to be sure it includes the letters SJ or later.

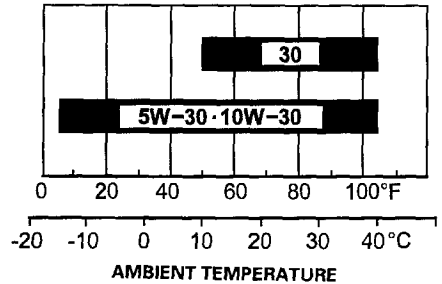

SAE 10W-30 is recommended for general use. Other viscosities shown in the chart may be used when the average temperature in your area is within the recommended range.

The engine protection system will automatically stop the engine before the oil pressure falls below the safe limit. However, to avoid the inconvenience of an unexpected shutdown, you should inspect the oil level regularly.

1. Remove the oil filler cap and wipe the dipstick clean.
2. Insert the dipstick into the oil filler neck, but do not screw it in.
3. Check the oil level shown on the dipstick. If near the lower level, fill to the upper level with the recommended oil.

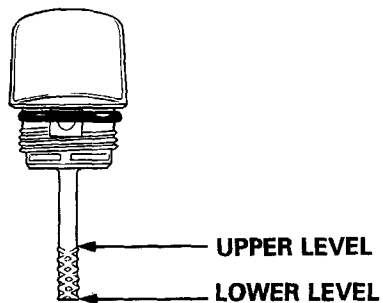
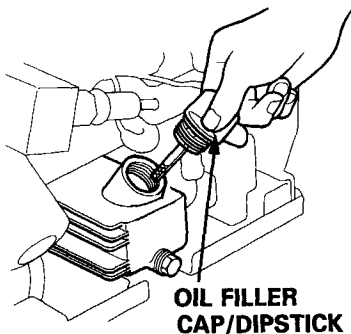

FUEL

Before starting the generator, check for fuel system leaks. Repair any fuel leaks before starting the generator.

▲ WARNING Gasoline is extremely flammable, and gasoline vapor can explode, causing serious injury or death. Use extreme care when handling gasoline.

Keep flames and sparks away, and do not smoke in the area. Be sure the engine compartment is dry and clear of fuel vapor before starting the generator.

Fuel Recommendation

This engine is certified to operate on regular unleaded gasoline with a pump octane rating of 86 or higher.

Never use stale or contaminated gasoline or oil/gasoline mixture. Avoid getting dirt or water in the fuel tank.

You may use regular unleaded gasoline containing no more than; 10% ethanol (E10) or 5% methanol by volume. In addition, methanol must contain cosolvents and corrosion inhibitors.

Use of fuels with content of ethanol or methanol greater than above may cause starting and/or performance problems. It can also damage metal, rubber, and plastic parts of the fuel system.

Engine damage or performance problems that result from the use of gasoline with percentages of ethanol or methanol greater than shown above are not covered by warranty.

If your equipment will be used on an infrequent or intermittent bases, please refer to the fuel section of the STORAGE chapter (page 35) for additional information regarding fuel deterioration.

NOTICE

Gasoline can spoil very quickly depending on factors such as light exposure, temperature, time and regional fuel additives.

In worst cases, gasoline can be contaminated within 30 days.

Using contaminated gasoline can seriously damage the engine (carburetor clogged, valve stuck).

Damage due to contaminated or spoiled fuel is not covered under the *warranty*.

To avoid this, please strictly follow these recommendations:

- Only use specified gasoline (see page 13).
- Use fresh and clean gasoline.
- To slow deterioration, keep gasoline in a certified fuel container.
- For long storage (more than 30 days) is foreseen, follow the storage procedures on page 35.

AIR CLEANER

Check the air cleaner element to be sure it is clean and in good condition. Clean or replace the element if necessary (see page 31).

NOTICE Never run the engine without the air cleaner. Rapid engine wear will result from contaminants such as dust and dirt being drawn through the carburetor into the engine.

COOLANT

⚠ WARNING

- Coolant may cause skin, eye, and mucous membrane irritation. Breathing high concentrations of mist or vapors may cause nausea. **SKIN or EYE CONTACT:** flush with water and go to a hospital. **IF SWALLOWED:** induce vomiting and call a physician.
- **KEEP OUT OF REACH OF CHILDREN.**

Check the coolant level in the reserve tank while parked on a level surface.

When the engine is at operating temperature, the coolant level should be between the MIN and MAX marks on the reserve tank. If the level is near the MIN mark, add coolant to bring the level up to the MAX mark.

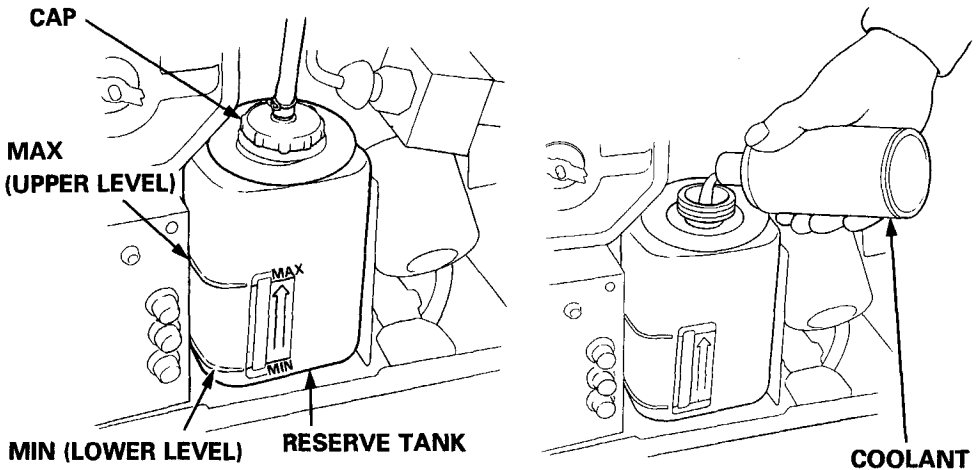

The engine protection system will automatically stop the engine if the coolant becomes excessively hot, which may occur if the coolant level is too low. To avoid the inconvenience of an unexpected shutdown, inspect the coolant level in the reserve tank regularly.

If there is no coolant in the reserve tank:

Make sure the engine is cool, then check the coolant system for leaks and have repairs made if needed. Add coolant to the radiator and reserve tank before starting the engine.

⚠ WARNING Hot coolant is under pressure. If you remove the radiator cap when the engine is hot, you may be scalded. Wait for the engine to cool.

1. When the engine is cool, relieve any remaining coolant pressure by turning the radiator cap counterclockwise until it reaches its stop; **DO NOT PRESS DOWN WHILE TURNING THE CAP**. After all pressure has been relieved, press the cap down and continue turning the cap to remove it.

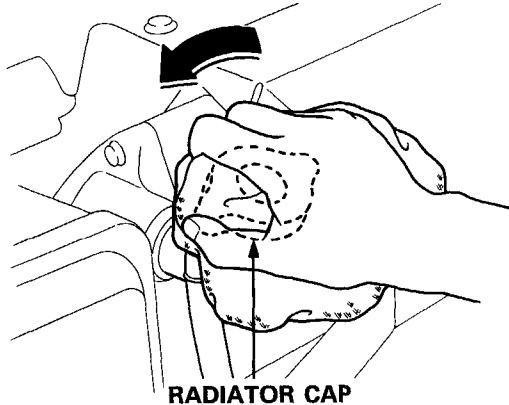

2. Fill the reserve tank to **MAX** mark with coolant.
3. Fill the radiator with coolant, and reinstall the radiator cap. Tighten the cap securely.

Antifreeze/Coolant Recommendation

Use high quality ethylene glycol coolant that is specifically formulated for aluminum engines. Mix the coolant with low-mineral drinking water or distilled water.

A 50/50 mixture of ethylene glycol coolant and water is recommended for most temperatures, and it provides good corrosion protection. A higher concentration of ethylene glycol decreases cooling efficiency but is recommended if additional protection against freezing is needed. A concentration of less than 40% antifreeze will not provide enough corrosion protection.

NOTICE The wrong type of coolant, hard water, or salt water can cause corrosion damage in the engine.

EXHAUST SYSTEM

Check the exhaust system for any damage or deterioration. Look for dents or leaks caused by rust.

⚠ WARNING

Exhaust contains poisonous carbon monoxide gas that can build up to dangerous levels in closed areas.

Breathing carbon monoxide can cause unconsciousness or death.

Never run the generator in a closed, or even partly closed area where people may be present.

STARTING AND STOPPING THE ENGINE

Starting the Engine

For your safety, do not operate the generator in an enclosed area such as a garage. Your generator's exhaust contains poisonous carbon monoxide gas that can collect rapidly in an enclosed area and cause illness or death.

⚠ WARNING

Exhaust contains poisonous carbon monoxide gas that can build up to dangerous levels in closed areas.

Breathing carbon monoxide can cause unconsciousness or death.

Never run the generator in a closed, or even partly closed area where people may be present.

You can start and stop the generator by using the engine switch on the generator control box, or by using the engine switch on the remote control panel (optional part).

1. Turn off all electrical loads (lights and appliances).
2. Push the engine switch to **START**, and hold the switch in that position until the engine starts and the pilot lamp glows steadily.

If the engine stops a few seconds after starting, this may indicate that the engine protection system has been activated (see page 21). Check the engine oil and coolant levels before attempting to restart the generator.

NOTICE

Operating the starter motor for more than 5 seconds can damage the motor. If the engine fails to start, release the switch and wait 10 seconds before operating the starter again.

**20A CIRCUIT BREAKER
(EV6010 air conditioner
circuit)**

**30A CIRCUIT BREAKER
(EV4010 and EV6010)**

ENGINE SWITCH

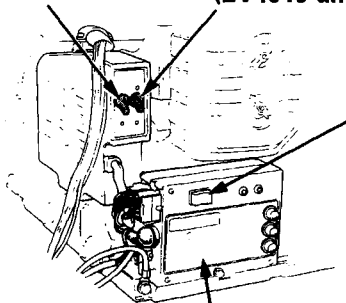

CONTROL BOX

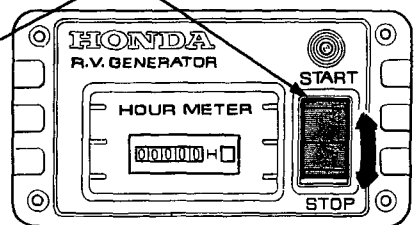

**REMOTE CONTROL PANEL
(optional part)**

-
- If you experience difficulty starting the engine, turn the circuit breaker(s) OFF to be sure there is no electrical load on the generator, then push the engine switch to START again. Turn the circuit breaker(s) ON after the engine starts.
 - If the engine stops because it ran out of fuel, then, after refilling the vehicle's fuel tank, it may be necessary to operate the starter repeatedly until fuel reaches the carburetor.

Stopping the Engine

Push the engine switch to STOP, and release the switch. It is not necessary to hold the switch until the engine stops.

GENERATOR USE

For your safety, do not operate the generator in an enclosed area such as a garage. Your generator's exhaust contains poisonous carbon monoxide gas that can collect rapidly in an enclosed area and cause illness or death.

⚠ WARNING

Exhaust contains poisonous carbon monoxide gas that can build up to dangerous levels in closed areas.

Breathing carbon monoxide can cause unconsciousness or death.

Never run the generator in a closed, or even partly closed area where people may be present.

Be careful that the exhaust is not directed into an area that you or your neighbors will use as living space. Avoid the exhaust area when the generator is running.

Placing awnings or similar structures in the exhaust area will restrict ventilation; this may cause exhaust gas to build up and enter living areas.

Obstructions, such as trees, rocks, dirt or snow embankments, or heavy brush can also restrict ventilation. Be sure the area near the exhaust pipe is clear of obstructions before starting the generator.

Be especially careful in snowy areas. Snow may build up near the exhaust pipe and trap exhaust gas, causing it to enter the living area.

Be sure that anyone who operates the generator receives proper instruction. Do not let children operate the generator without parental supervision.

APPLIANCE OPERATION

To avoid overloading the generator, be sure the total power requirements of all connected appliances do not exceed maximum generator output (EV4010: 4.0 kVA, EV6010: 6.0 kVA).

Most appliance and power tool motors require more than their rated operating current for start-up. To match appliance power needs to generator capability, allow a sufficient generator power reserve to accommodate motor start-up requirements.

Be sure that all appliances are in good working order before connecting them to the generator. If an appliance begins to operate abnormally, becomes sluggish, or stops suddenly, turn off the appliance or the generator circuit breaker immediately. Disconnect the appliance, and determine whether the problem is due to appliance malfunction or generator overloading.

ENGINE PROTECTION SYSTEM

The engine protection system will automatically stop the engine to prevent damage from lack of lubrication or overheating.

Low Oil Level Protection

If there is a loss of oil pressure, which may indicate low oil level, the engine protection system will automatically stop the engine.

If this occurs, check the engine oil level, and add oil if the level is low (see page 12).

Engine Overheating Protection

If the engine or coolant becomes too hot, the engine protection system will automatically stop the engine, and the temperature warning lamp will light. The temperature warning lamp is located on the generator control box.

If this occurs, check the coolant level, and refill if the coolant level is low (see pages 15 & 16). If the cooling system leaks, or if the temperature warning lamp lights with the cooling system properly filled, take the generator to your servicing dealer.

NOTE: Allow an overheated engine to cool for 15 to 40 minutes before re-starting. If restarted while overheated, the engine protection system will immediately stop the engine again. The generator is ready for operation when the temperature warning lamp is no longer lit.

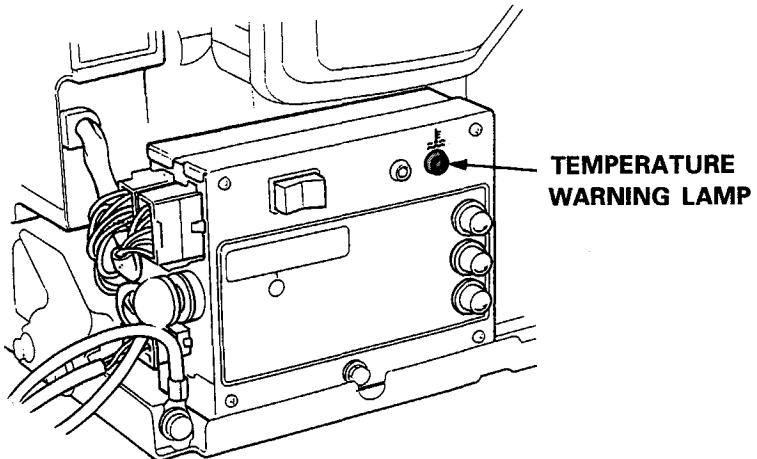

CIRCUIT BREAKERS AND FUSES

The generator's electrical system is protected by 3 fuses in the generator control unit and a circuit breaker for the AC output circuit. The EV6010 has a second circuit breaker for a separate air conditioner circuit.

Circuit Breakers

An overload will trip (switch off) the circuit breaker. If this happens, reduce the electrical load on the circuit. Wait a few minutes before resetting the circuit breaker.

Fuses

In the event of fuse failure, unscrew the fuse holder and install a replacement fuse of the specified rating. Then reinstall the fuse holder and tighten it securely.

NOTICE Using fuses with ratings higher than specified can cause a fire or equipment damage.

20A CIRCUIT BREAKER (EV6010 air conditioner circuit)
30A CIRCUIT BREAKER (EV4010 and EV6010)

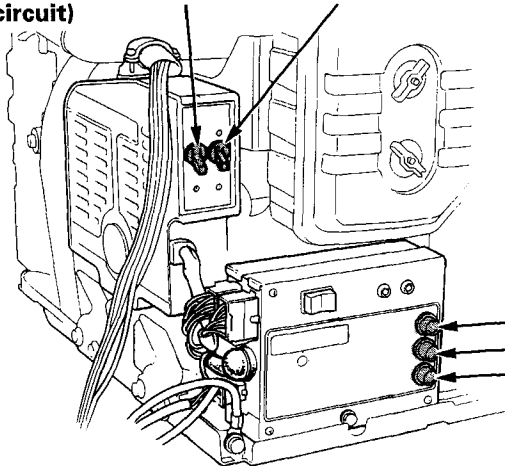

FUSE HOLDER	FUSE RATING
F1	15A
F2	4A
F3	4A

FUSE HOLDERS

F1
F2
F3

If frequent fuse failure occurs, consult your servicing dealer to determine the cause. Correct the problem before operating the generator again.

Carburetor Modification for High Altitude Operation

At high altitude, the standard carburetor air/fuel mixture will be too rich. Performance will decrease, and fuel consumption will increase. A very rich mixture will also foul the spark plugs and cause hard starting. Operation at an altitude that differs from that at which this engine was certified, for extended periods of time, may increase emissions.

High altitude performance can be improved by specific modifications to the carburetor. If you always operate your generator at altitudes above 5,000 feet (1,500 meters), have your authorized Honda servicing dealer perform this carburetor modification. This engine, when operated at high altitude with the carburetor modifications for high altitude use, will meet each emission standard throughout its useful life.

Even with carburetor modification, engine horsepower will decrease about 3.5% for each 1,000 foot (300-meter) increase in altitude. The effect of altitude on horsepower will be greater than this if no carburetor modification is made.

NOTICE

When the carburetor has been modified for high altitude operation, the air/fuel mixture will be too lean for low altitude use. Operation at altitudes below 5,000 feet (1,500 meters) with a modified carburetor may cause the engine to overheat and result in serious engine damage. For use at low altitudes, have your servicing dealer return the carburetor to original factory specifications.

MAINTENANCE

The Importance of Maintenance

Good maintenance is essential for safe, economical, and trouble-free operation. It will also help reduce air pollution.

WARNING

Improper maintenance or failure to correct a problem before operation can cause a malfunction in which you can be seriously hurt or killed.

Always follow the inspection and maintenance recommendations and schedules in this owner's manual.

To help you properly care for your generator, the following pages include a maintenance schedule, routine inspection procedures, and simple maintenance procedures using basic hand tools. Other service tasks that are more difficult, or require special tools, are best handled by professionals and are normally performed by a Honda technician or other qualified mechanic.

The maintenance schedule applies to normal operating conditions. If you operate your generator under severe conditions, such as sustained high-load or high-temperature operation, or use it in unusually wet or dusty conditions, consult your servicing dealer for recommendations applicable to your individual needs and use.

Remember that your servicing dealer knows your generator best and is fully equipped to maintain and repair it.

To ensure the best quality and reliability, use only new, Honda Genuine parts or their equivalents for repair or replacement.

Maintenance, replacement, or repair of the emission control devices and systems may be performed by any engine repair establishment or individual, using parts that are "certified" to EPA standards.

Maintenance Safety

Some of the most important safety precautions follow. However, we cannot warn you of every conceivable hazard that can arise in performing maintenance. Only you can decide whether or not you should perform a given task.

WARNING

Failure to properly follow maintenance instructions and precautions can cause you to be seriously hurt or killed.

Always follow the procedures and precautions in the owner's manual.

Safety precautions

- Make sure the engine is off before you begin any maintenance or repairs. This will eliminate several potential hazards:
 - **Carbon monoxide poisoning from engine exhaust.**
Be sure there is adequate ventilation whenever you operate the engine.
 - **Burns from hot parts.**
Let the engine and exhaust system cool before touching.
 - **Injury from moving parts.**
Do not run the engine unless instructed to do so.
- Read the instructions before you begin, and make sure you have the tools and skills required.
- To reduce the possibility of fire or explosion, be careful when working around gasoline. Use only a nonflammable solvent, not gasoline, to clean parts. Keep cigarettes, sparks, and flames away from all fuel-related parts.

Emission Control System Information

Source of Emissions

The combustion process produces carbon monoxide, oxides of nitrogen, and hydrocarbons. Control of hydrocarbons and oxides of nitrogen is very important because, under certain conditions, they react to form photochemical smog when subjected to sunlight. Carbon monoxide does not react in the same way, but it is toxic.

Honda utilizes appropriate air/fuel ratios and other emission control systems to reduce the emissions of carbon monoxide, oxides of nitrogen, and hydrocarbons.

Additionally, Honda fuel systems utilize components and control technologies to reduce evaporative emissions.

The U.S. Clean Air Act

EPA regulations require all manufacturers to furnish written instructions describing the operation and maintenance of emission control systems. The following instructions and procedures must be followed in order to keep the emissions from your Honda engine within the emission standards.

Tampering and Altering

Tampering with or altering the emission control system may increase emissions beyond the legal limit. Among those acts that constitute tampering are:

- Removal or alteration of any part of the intake, fuel, or exhaust systems.
- Altering or defeating the governor linkage or speed-adjusting mechanism to cause the engine to operate outside its design parameters.

Problems That May Affect Emissions

If you are aware of any of the following symptoms, have your engine inspected and repaired by your servicing dealer.

- Hard starting or stalling after starting.
- Rough idle.
- Misfiring or backfiring under load.
- Afterburning (backfiring).
- Black exhaust smoke or high fuel consumption.

Replacement Parts

The emission control systems on your Honda engine were designed, built, and certified to conform with applicable emission regulations. We recommend the use of Honda Genuine parts whenever you have maintenance done. These original-design replacement parts are manufactured to the same standards as the original parts, so you can be confident of their performance. The use of replacement parts that are not of the original design and quality may impair the effectiveness of your emission control system.

A manufacturer of an aftermarket part assumes the responsibility that the part will not adversely affect emission performance. The manufacturer or rebuilder of the part must certify that use of the part will not result in a failure of the engine to comply with emission regulations.

Maintenance

Follow the *Maintenance Schedule* on page 28. Remember that this schedule is based on the assumption that your machine will be used for its designed purpose. Sustained high-load or high-temperature operation, or use in unusually wet or dusty conditions, will require more frequent service.

MAINTENANCE SCHEDULE

REGULAR SERVICE PERIOD (3)		Each use	First month or 20 hrs.	Every 3 months or 50 hrs.	Every 6 months or 100 hrs.	Every year or 300 hrs.
Item	Perform at every indicated month or operating hour interval, whichever comes first.					
Engine oil	Check level	<input type="radio"/>				
	Change		<input type="radio"/>		<input type="radio"/>	
Engine oil filter	Replace	Every 2 years (2)				
Air cleaner	Check	<input type="radio"/>				
	Clean			<input type="radio"/> (1)		
Battery electrolyte	Check level	<input type="radio"/>				
Radiator Coolant	Check	<input type="radio"/>				
	Change	Every 2 years (2)				
Spark plug	Check-adjust				<input type="radio"/>	
	Replace					<input type="radio"/>
Spark arrester	Clean				<input type="radio"/>	
Valve Clearance	Check-adjust					<input type="radio"/> (2)
Combustion chamber	Clean	After every 500 hrs (2)				
Fuel tube	Check	Every 2 years (Replace if necessary) (2)				

- (1) Service more frequently when used in dusty areas.
- (2) These items should be serviced by your servicing dealer, unless you have the proper tools and are mechanically proficient. Refer to Honda shop manual for service procedures.
- (3) For commercial use, log hours of operation to determine proper maintenance intervals.

Failure to follow this maintenance schedule could result in non-warrantable failures.

MAINTENANCE RECORD

When scheduled maintenance is performed, record the actual hour meter readings below.

Interval Items Hours	Every 50 Hr.	Every 100 Hr.	Every 300 Hr.
	• Air cleaner element cleaning	• Engine oil change • Spark arrester cleaning • Spark plug maintenance	• Valve clearance adjustment • Spark plug replacement
50 Hr.	<input type="radio"/>		
100 Hr.	<input type="radio"/>	<input type="radio"/>	
150 Hr.	<input type="radio"/>		
200 Hr.	<input type="radio"/>	<input type="radio"/>	
250 Hr.	<input type="radio"/>		
300 Hr.	<input type="radio"/>	<input type="radio"/>	<input type="radio"/>
350 Hr.	<input type="radio"/>		
400 Hr.	<input type="radio"/>	<input type="radio"/>	
450 Hr.	<input type="radio"/>		
500 Hr.	<input type="radio"/>	<input type="radio"/>	
550 Hr.	<input type="radio"/>		
600 Hr.	<input type="radio"/>	<input type="radio"/>	<input type="radio"/>

ENGINE OIL CHANGE

Drain the oil while the engine is warm to assure rapid and complete draining.

1. Remove the oil filter cap/dipstick and the oil drain plug, and allow the oil to drain into a suitable container.
2. Check that the drain plug washer is in good condition (replace if necessary), then install the oil drain plug and tighten it securely.
3. Refill with the recommended oil (see page 12) to the upper level on the dipstick. Install the oil filler cap/dipstick.
4. Run the engine for a few minutes, then recheck the oil level. Add oil if necessary.

OIL FILLER CAP/DIPSTICK

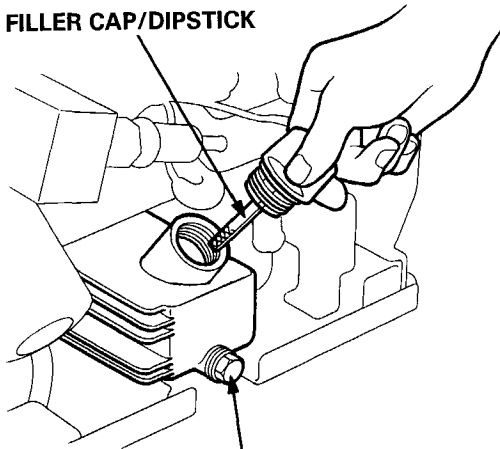

OIL DRAIN PLUG

Wash your hands with soap and water after handling used oil.

Please dispose of used motor oil in a manner that is compatible with the environment. We suggest you take it in a sealed container to your local service station or recycling center for reclamation. Do not throw it in the trash or pour it on the ground or pour it down a drain.

AIR CLEANER SERVICE

A dirty air cleaner will restrict air flow to the carburetor, reducing engine performance. If the generator is operated in very dusty areas, clean the air cleaner more frequently than specified in the MAINTENANCE SCHEDULE.

⚠ WARNING Using gasoline or flammable solvent to clean the filter element can cause a fire or explosion. Use only soapy water or nonflammable solvent.

NOTICE

Operating the engine without an air filter or with a damaged air filter will allow dirt to enter the engine, causing rapid engine wear. This type of damage is not covered by warranty.

1. Remove the wing nuts and air cleaner cover. Remove the elements and separate them. Carefully check both elements for holes or tears, and replace if damaged.
2. Foam element: Clean in warm soapy water, rinse, and allow to dry thoroughly, or clean in nonflammable solvent and allow to dry. Dip the element in clean engine oil and squeeze out all excess oil. The engine will smoke during initial running if too much oil is left in the foam.
3. Paper element: Tap the element several times on a hard surface to remove excess dirt, or blow compressed air through the filter from the inside. Never try to brush off dirt; brushing will force dirt into the fibers.
4. Reinstall the air cleaner elements and the cover.

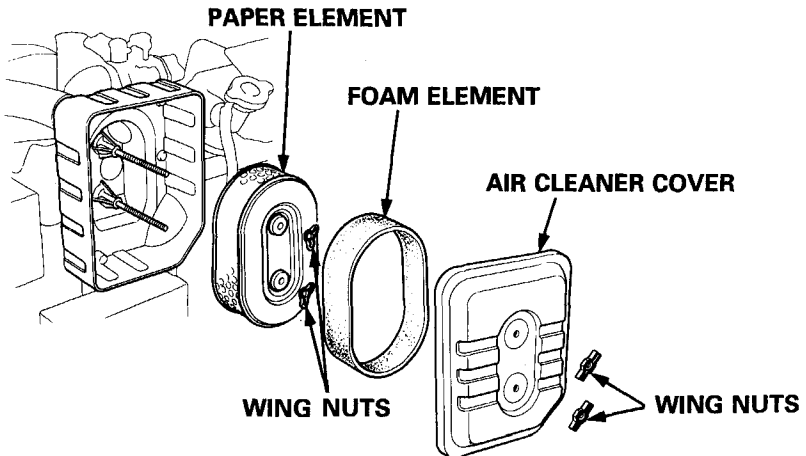

SPARK PLUG SERVICE

In order to service the spark plug, you will need a spark plug wrench (commercially available).

Recommended spark plugs: BPR4HS (NGK)

For good performance, the spark plugs must be properly gapped and free of deposits.

NOTICE

An incorrect spark plug can cause engine damage.

If the engine has been running, let it to cool before servicing the spark plug.

1. Disconnect the spark plug caps, and remove any dirt from around the spark plug area.
2. Remove the spark plugs with a spark plug wrench.

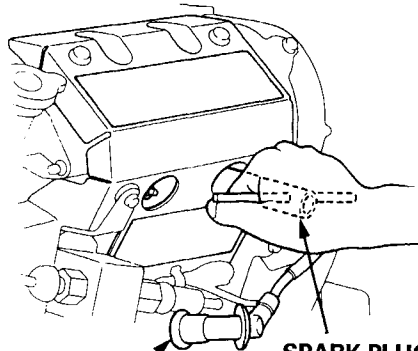

SPARK PLUG CAP

SPARK PLUG WRENCH

3. Inspect the spark plugs. Replace them if the electrodes are worn or fouled, or the insulators are cracked or chipped.
4. Measure the electrode gap of each spark plug with a wire-type feeler gauge. The gap should be 0.024 – 0.028 in (0.6 – 0.7 mm). Correct the gap, if necessary, by carefully bending the side electrode.

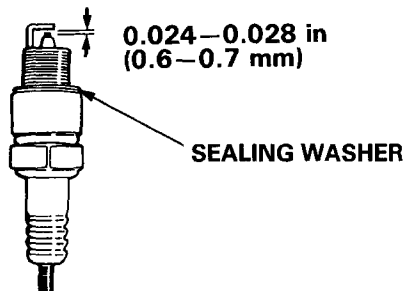

-
5. Install the spark plugs carefully by hand to avoid cross-threading.

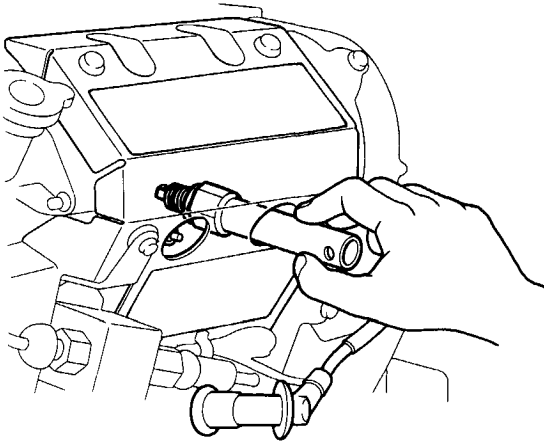

6. After the spark plugs are seated, tighten with a spark plug wrench to compress the washers.

If installing new spark plugs, tighten $1/2$ turn after the spark plugs seat to compress the washers. If reinstalling used spark plugs, tighten $1/8$ – $1/4$ turn after the spark plugs seat.

NOTICE The spark plugs must be securely tightened. Improperly tightened spark plugs can become very hot and could damage the engine. Never use spark plugs which have an improper heat range. Use only the recommended spark plugs or equivalent.

7. Attach the spark plug caps securely.

SPARK ARRESTER SERVICE

If the generator has been running, the muffler will be very hot. Allow it to cool before proceeding.

The spark arrester must be serviced every 100 hours to maintain its efficiency.

Clean the spark arrester as follows:

1. Remove the spark arrester cleaning bolt.
2. Start the engine and run it for several minutes. Exhaust gas will blow loose carbon particles through the hole where the cleaning bolt was removed.

⚠ WARNING Exhaust contains poisonous carbon monoxide, a colorless and odorless gas that can cause loss of consciousness and may lead to death. Provide enough ventilation to keep exhaust gas from building up.

3. Reinstall the cleaning bolt and tighten it securely.

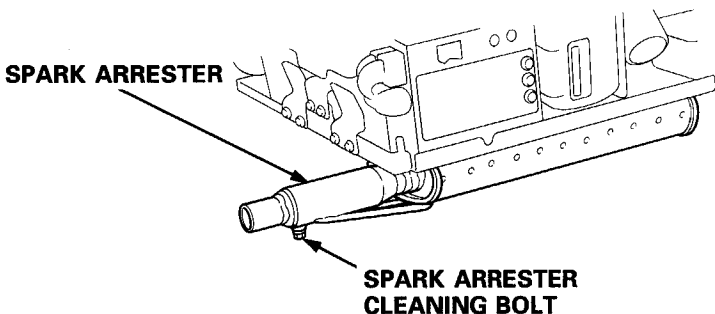

NOTICE

Depending on the region where you operate your generator, fuel formulations may deteriorate and oxidize rapidly. Fuel deterioration and oxidation can occur in as little as 30 days and may cause damage to the carburetor and/or fuel system. Please check with your servicing dealer for local storage recommendations.

For storage of less than 1 month:

No storage preparation required.

For storage of 1 to 2 months:

1. Fill the vehicle's fuel tank with fresh gasoline, and add a gasoline stabilizer that is formulated to extend fuel storage life.
2. Run the generator's engine for 10 minutes to be sure the carburetor float bowl contains treated gasoline.

For storage of 2 months or longer:

1. Change the engine oil (see page 30).
2. Remove the spark plugs, and pour a teaspoon of clean engine oil into each cylinder. Crank the engine for several seconds to distribute the oil, then reinstall the spark plugs.

If the cylinders are coated with oil, the engine will smoke briefly at start-up; this is normal.

3. Drain the carburetor by placing the drain tube in a suitable gasoline container and loosening the drain screw. Retighten the screw after draining.

⚠ WARNING Gasoline is extremely flammable, and gasoline vapor can explode, causing serious injury or death. Use extreme care when handling gasoline.

Keep flames and sparks away, and do not smoke in the area. Be sure the generator compartment is dry and clear of fuel vapor before starting the engine.

CARBURETOR DRAIN SCREW

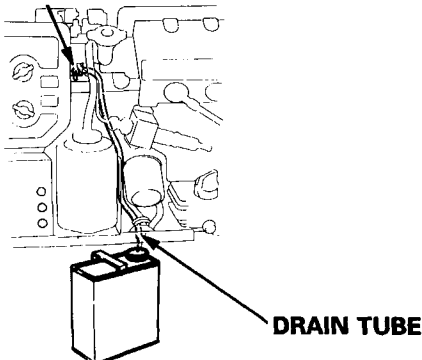

TROUBLESHOOTING

STARTER MOTOR WILL NOT OPERATE

1. Check the vehicle battery and battery connector to the generator.
2. Check the F1 fuse (see page 22).

STARTER MOTOR WORKS, BUT ENGINE WILL NOT START

1. Check fuel level. Some vehicles will not supply fuel to the generator when the fuel tank level is below a certain limit.
2. Turn off all electrical loads (lights and appliances), or turn the circuit breaker(s) OFF. Turn the circuit breaker(s) ON after the engine starts.
3. Check the F2 fuse (see page 22).
4. Check the spark plugs (see page 33). Be sure the spark plugs are clean and properly gapped. If the engine still does not start, install new spark plugs and try again.

ENGINE STARTS, BUT STOPS IMMEDIATELY

1. The engine protection system may have been activated (see page 21). If the temperature warning lamp is lit, check the coolant level; if not, check the engine oil level.
2. Check the F3 fuse (see page 22).

ENGINE RUNS, BUT THERE IS NO ELECTRICITY OUTPUT

1. Check that the generator circuit breaker is in the ON position.
2. If the vehicle is equipped to isolate the generator when using an outside power source, check to be sure the generator has been reconnected.
3. Check circuit breakers and ground fault circuit interrupters in the vehicle. If they have been tripped (switched off), check appliances or equipment for malfunction before further use.

EV4010

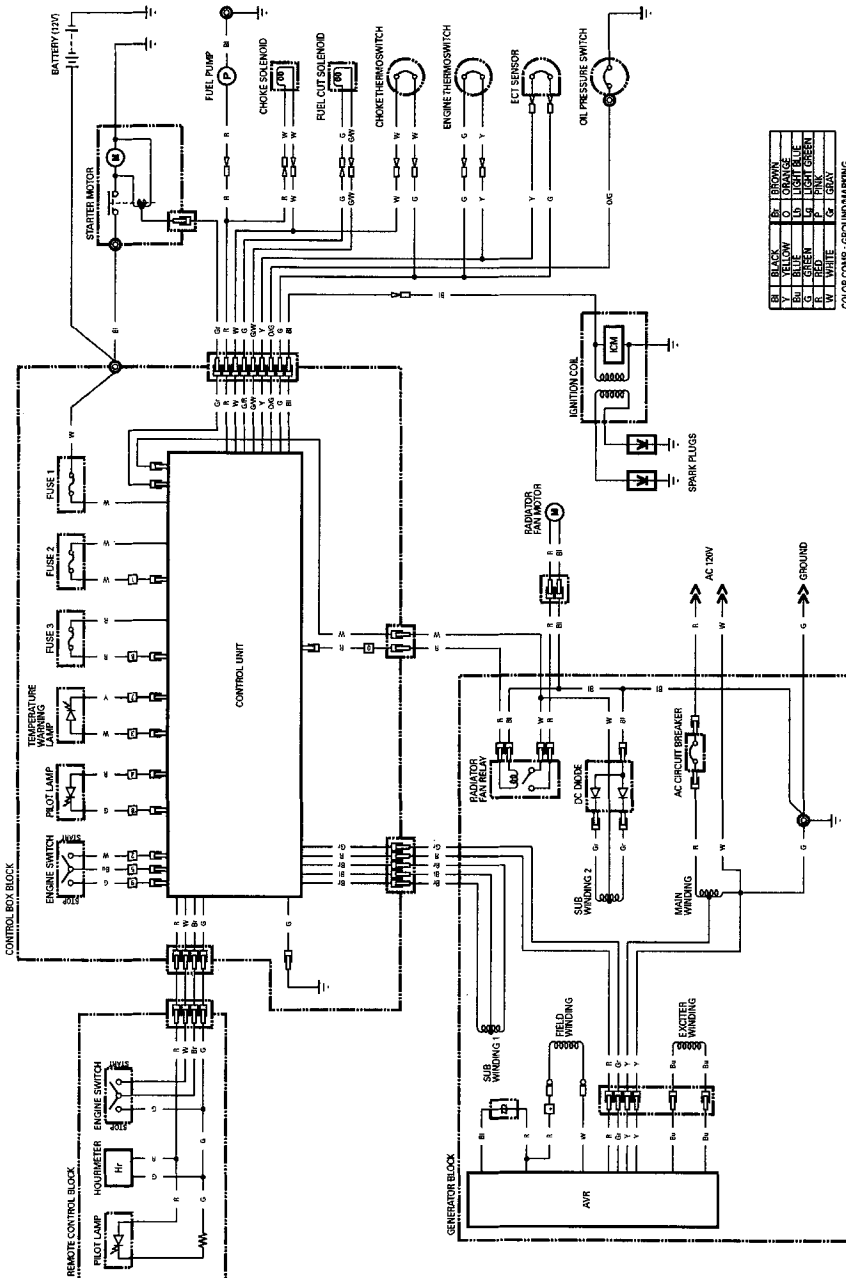

B	BLACK
BR	BROWN
Y	YELLOW
O	ORANGE
BL	BLUE
G	GREEN
LS	LIGHT GREEN
R	RED
P	PINK
LG	LIGHT GRAY

COLOR COMB: GROUNDING

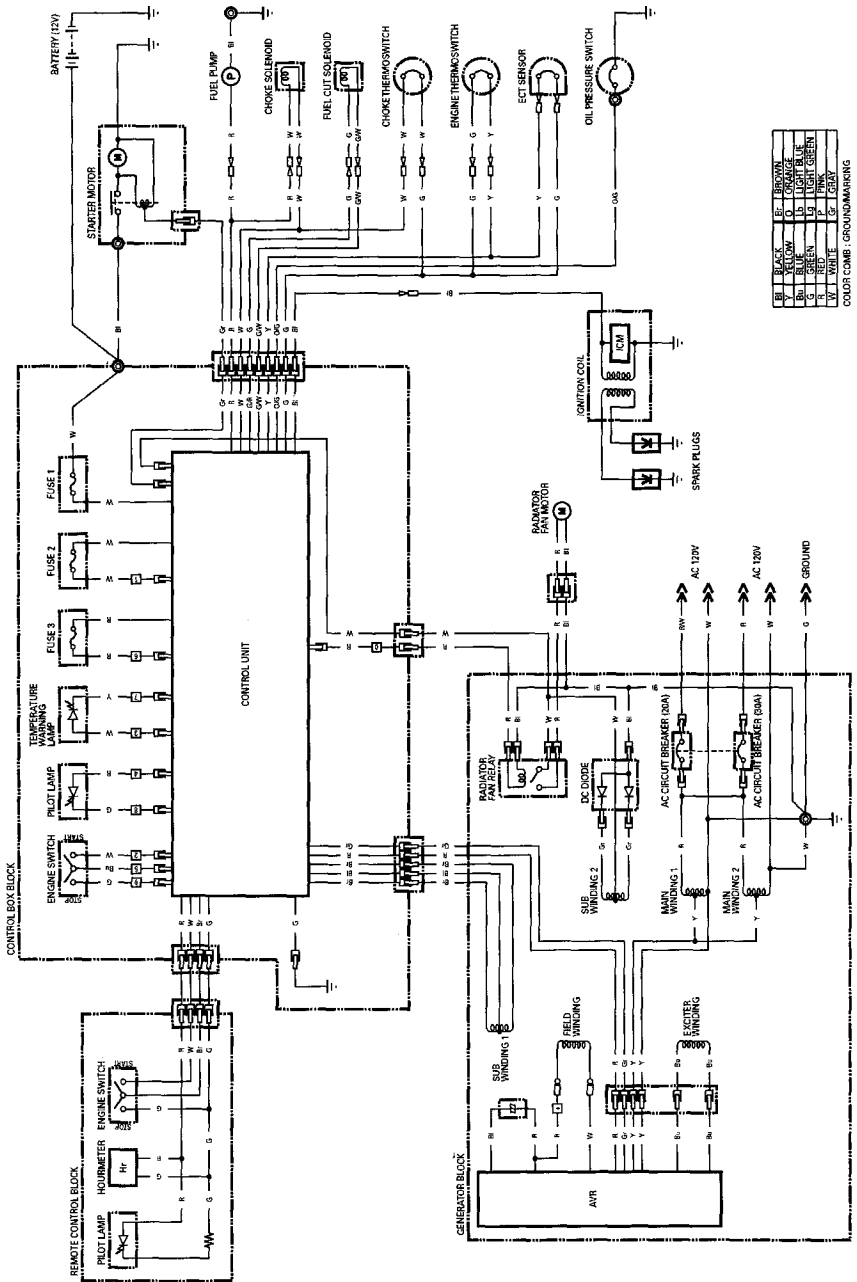

SPECIFICATIONS

Dimensions

Model	EV4010	EV6010
Power equipment description code	ECA	ECB
Length x Width x Height	25.6 x 19.0 x 14.2 in (650 x 483 x 361 mm)	
*Dry mass [weight]	203 lb (92 kg)	216 lb (98 kg)

* Muffler unit (EVM40 ACL type) is included.

Engine

Model	GX360K1
Engine type	4-stroke, OHC Twin cylinder
Displacement (Bore x Stroke)	21.9 cu in (359 cm ³) [2.3 x 2.7 in (58.0 x 68.0 mm)]
Compression ratio	8.5 : 1
Engine speed	3,600 rpm
Cooling system	Liquid cooled
Ignition system	Transistorized magneto
Oil capacity	1.27 US qt (1.2 ℓ, 1.06 Imp qt)
Spark plug	BPR4HS (NGK)

Generator

Model		EV4010	EV6010
Type		AN	
AC output	Rated voltage	120V	
	Rated frequency	60Hz	
	Rated ampere	33.5 A	50 A
	Rated output	4.0 KVA	6.0 KVA

Tune-up Specifications

ITEM	SPECIFICATION	MAINTENANCE
Spark plug gap	0.024 – 0.028 in (0.6 – 0.7 mm)	Refer to page: 32
Valve clearance	IN: 0.12 ± 0.02 mm (cold) EX: 0.20 ± 0.02 mm (cold)	See your authorized Honda dealer
Other specification	No other adjustment needed.	

Specifications may vary according to the types, and are subject to change without notice.

Honda Publications

Shop Manual

This manual covers complete maintenance and overhaul procedures. It is intended to be used by a skilled technician.

Available through your Honda dealer or through Helm Inc. at 1 (888) 292-5395 or visit www.hondapowerequipment.com/own.htm

Parts Catalog

This manual provides complete, illustrated parts lists. Available through your Honda dealer.

Accessories Catalog

Your authorized Honda power equipment dealer offers a wide selection of accessories (optional equipment) to make your generator even more useful.

Visit www.hondapowerequipment.com/acc.htm

and click on Generators and Welders to see the entire catalog of accessories.

Dealer Locator Information

To find an authorized Honda Servicing Dealer anywhere in the United States:

Call (800) 426-7701 or visit our web site:
www.hondapowerequipment.com/dea.htm

Customer Service Information

Servicing dealership personnel are trained professionals. They should be able to answer most questions you may have. If you encounter a problem that your dealer does not solve to your satisfaction, please discuss it with the dealership's management. The Service Manager or General Manager can help. Almost all problems are solved in this way.

If you are dissatisfied with the decision made by the dealership's management, contact the Honda Power Equipment Customer Relations Office. You can write to:

American Honda Motor Co., Inc.
Power Equipment Division
Customer Relations Office
4900 Marconi Drive
Alpharetta, Georgia 30005-8847

Or telephone: (770) 497-6400 8:30 am to 7:00 pm ET

When you write or call, please give us this information:

- Model and serial number (see page 10)
- Name of dealer who sold the generator to you
- Name and address of dealer who services your generator
- Date of purchase
- Your name, address, and telephone number
- A detailed description of the problem

HONDA

The Power of Dreams

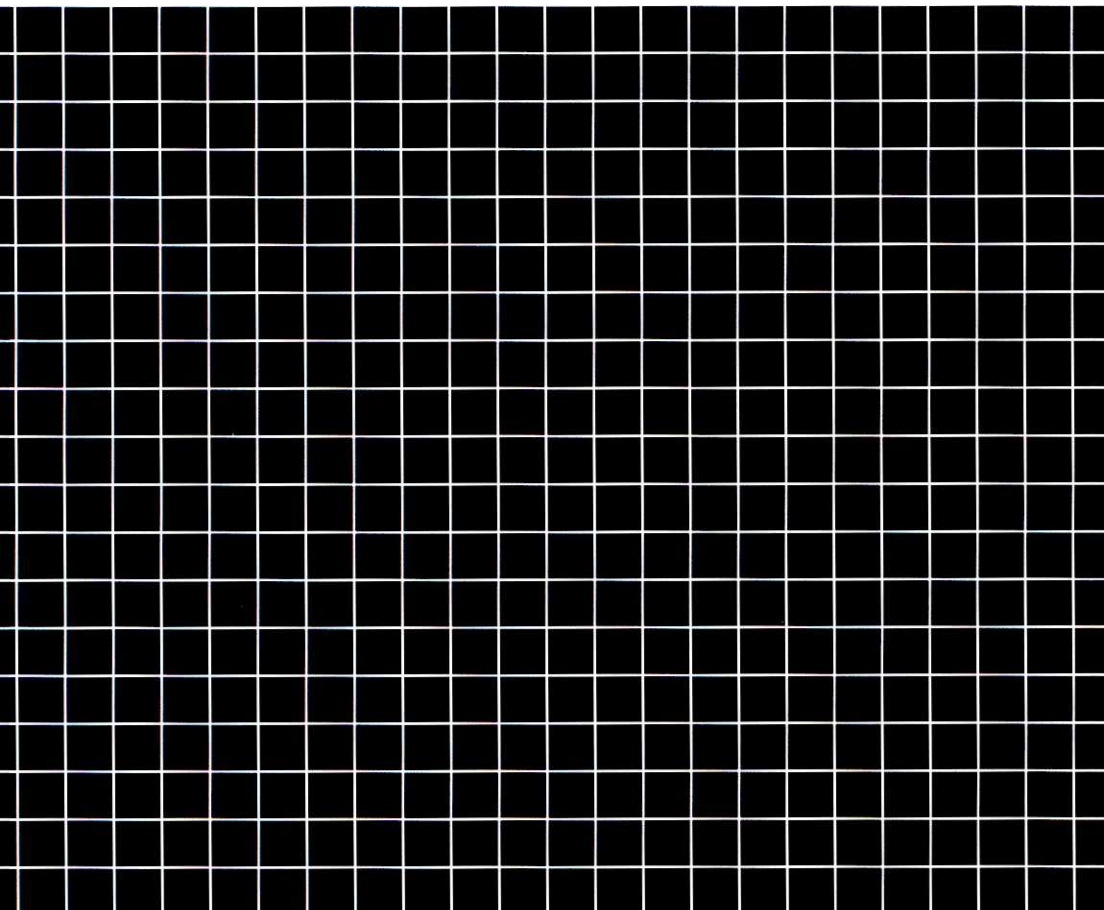

31ZB5801
00X31-ZB5-8010

EM3 (AH) (英) (Y) (YI) 500.2008.03
(Hi) Printed in Japan