

HONDA

Power

Equipment

Owner's Manual

EB3500X

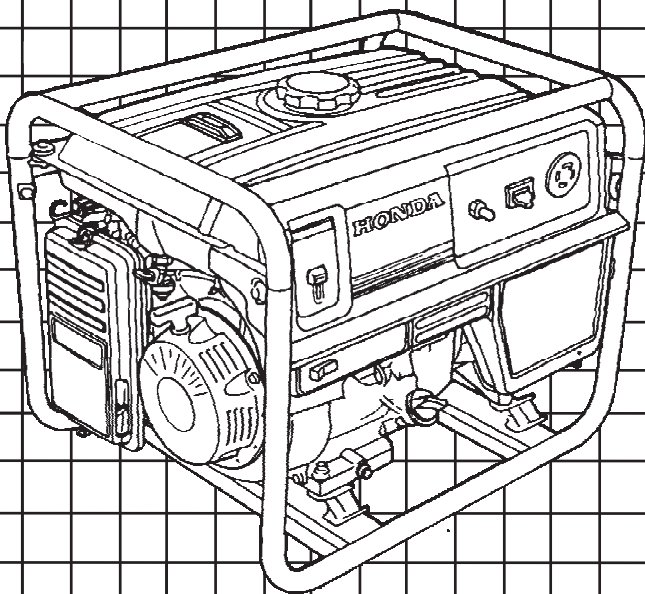



Thank you for purchasing a Honda generator.

This manual covers operation and maintenance of the EB3500X generators. All information in this publication is based on the latest product information available at the time of approval for printing.

Honda Motor Co., Ltd. reserves the right to make changes at any time without notice and without incurring any obligation.

No part of this publication may be reproduced without written permission.

This manual should be considered a permanent part of the generator and remain with the generator when sold.

Pay special attention to statements preceded by the following words:

WARNING Indicates a strong possibility of severe personal injury or loss of life if instructions are not followed.

CAUTION: Indicates a possibility of personal injury or equipment damage, if instructions are not followed.

NOTE: Gives helpful information.

If a problem should arise, or if you have any questions about the generator, consult an authorized Honda dealer.

WARNING The Honda generator is designed to give safe and dependable service if operated according to instructions. Read and understand the Owner's Manual before operating the generator. Failure to do so could result in personal injury or equipment damage.

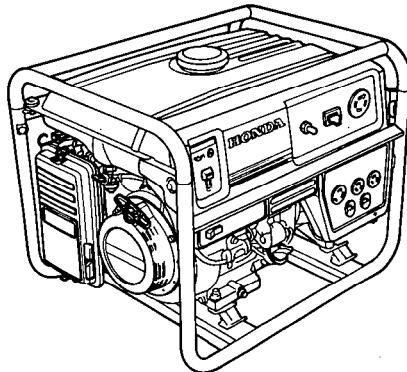

CONTENTS

CONTENTS

1. WARNING LABEL LOCATION	3
2. GENERATOR SAFETY	5
3. COMPONENT IDENTIFICATION	6
4. PRE-OPERATION CHECK	8
5. STARTING THE ENGINE	12
6. GENERATOR USE	15
7. STOPPING THE ENGINE	18
8. MAINTENANCE	20
9. TRANSPORTING/STORAGE	28
10. TROUBLESHOOTING	30
11. SPECIFICATIONS	32
12. WIRING DIAGRAM	33
13. HANGER KIT INSTALLATION	34
14. INSTALLATION OF OPTIONAL PARTS	35
15. WARRANTY SERVICE	36

1. WARNING LABEL LOCATION

WARNING DO NOT USE INDOORS. EXHAUST GAS CONTAINS POISONOUS CARBON MONOXIDE.

ATTENTION NE PAS UTILISER DANS UN ENDROIT FERME A CAUSE DU RISQUE D'EMPOISONNEMENT DU GAZ.

ATENCION NO LO USE EN LUGARES CERRADOS PORQUE EL MONOXIDE DE CARBONO ES VENENOSO.

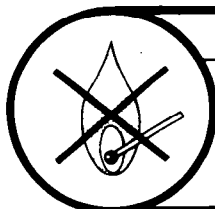

- CHECK FOR SPILLED FUEL OR FUEL LEAKS.
STOP ENGINE BEFORE REFUELING.
- CONTROLER QU'IL N'Y A NI FUITE NI ESSENCE
REPAÑDUE SUR L'APPAREIL.
/ ARRETER LE MOTEUR AVANT DE REFAIRE LE PLEIN.
- INSPECCIONAR PARA COMBUSTIBLE DERRAMADO
O ESCAPE.
PARAR MOTOR ANTES DE ECHAR.

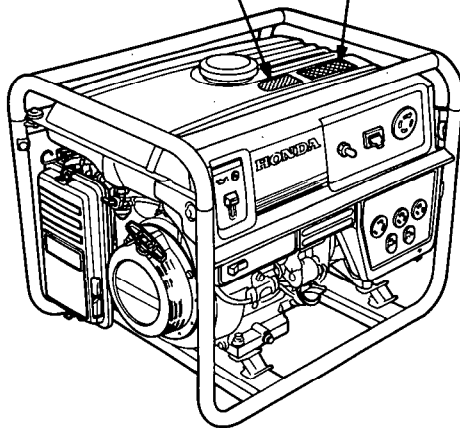

EB3500X HONDA MOTOR CO., LTD. MADE IN JAPAN (A)

<p>CAUTION</p> <p>■ BE SURE TO FILL CRANKCASE WITH RECOMMENDED OIL BEFORE USING. FOR DETAILED EXPLANATION, SEE THE OWNER'S MANUAL.</p>	<p>AC</p> <p>VOLTAGE 120/240V FREQUENCY 60Hz RATED OUTPUT 3.0kVA MAX. OUTPUT 3.5kVA PHASE 1Ø FUEL GASOLINE (PETROL)</p>
---	--

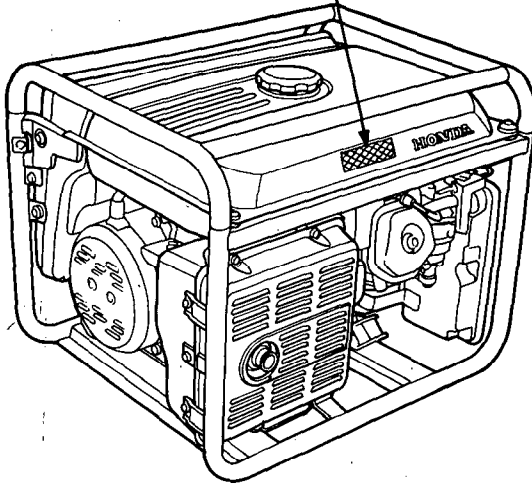

2. GENERATOR SAFETY

 **WARNING**

To ensure safe operation —

- Place the generator at least 1 m (3 ft) away from buildings or other equipment when operating the generator.
- Operate the generator on a level surface.
If the generator is tilted, fuel spillage may result.
- Exhaust gas contains poisonous carbon monoxide.
Never run the generator in an enclosed area.
Be sure to provide adequate ventilation.
- Know how to stop the generator quickly and understand operation of all the controls. Never permit anyone to operate the generator without proper instructions.
- Keep children and pets away from the generator when it is in operation.
- Keep away from rotating parts while the generator is running.
- The generator is a potential source of electrical shocks when misused; do not operate with wet hands.
Do not operate the generator in rain or snow and do not let it get wet.

3. COMPONENT IDENTIFICATION

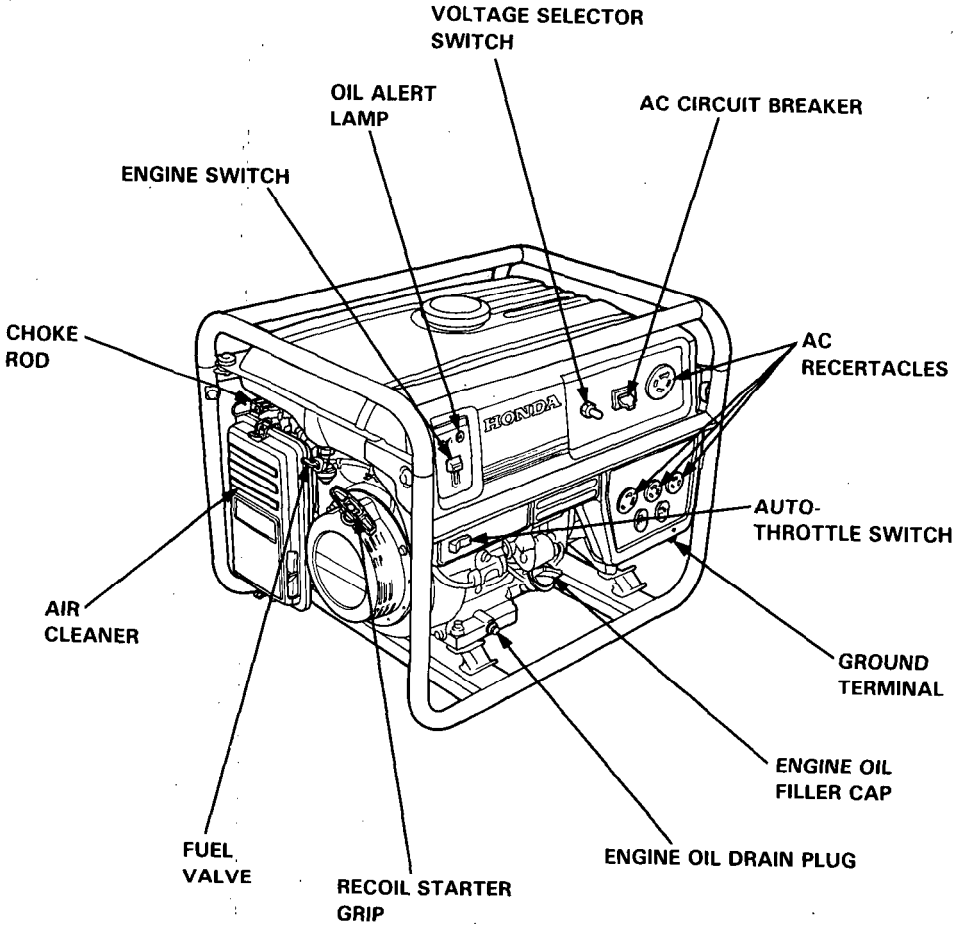

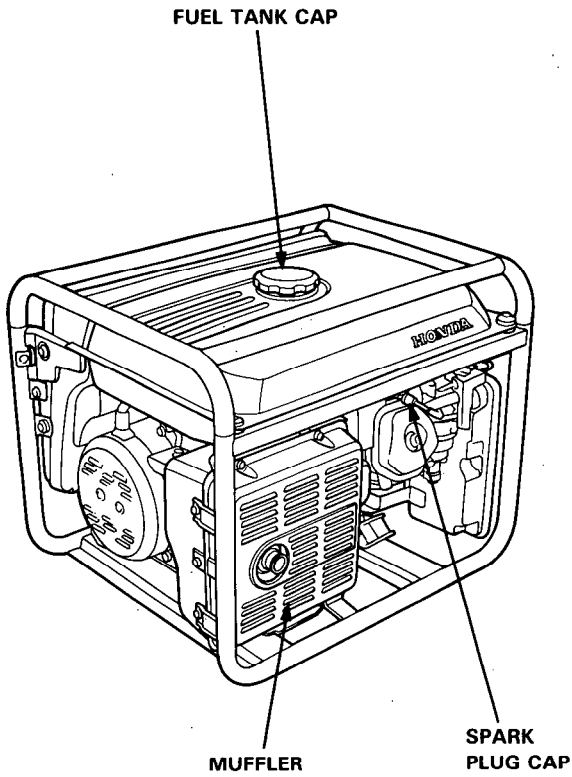

4. PRE-OPERATION CHECK

Engine Oil

CAUTION:

- Engine oil is a major factor affecting engine performance and service life. Non-detergent oils and vegetable oils are not recommended.
- Be sure to check the engine on a level surface with the engine stopped.

Use Honda 4-stroke oil or an equivalent high detergent premium quality motor oil certified to meet or exceed U.S. auto-mobile manufacturer's requirements for Service Classification SE or SF. (Motoroils classified SE or SF will show this designation on the container.)

SAE 10W-40 is recommended for general, all-temperature use. Other viscosities shown in the chart may be used when the average temperature in your area is within the indicated range.

1. Remove the oil filler cap and wipe the dipstick clean.
2. Insert the dipstick into the oil filler neck but do not screw it in.
3. If the level is low, fill to the top of the oil filler neck with the recommended oil.

CAUTION: Running the engine with insufficient oil can cause serious engine damage.

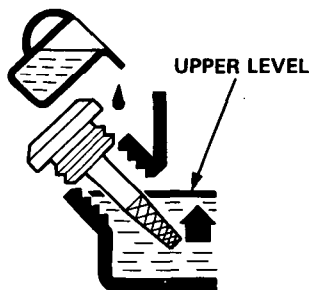
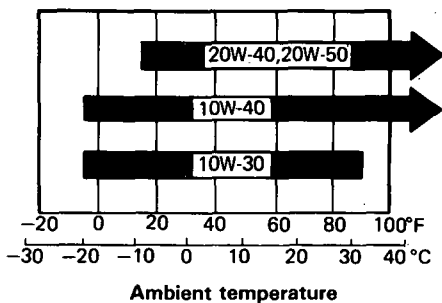
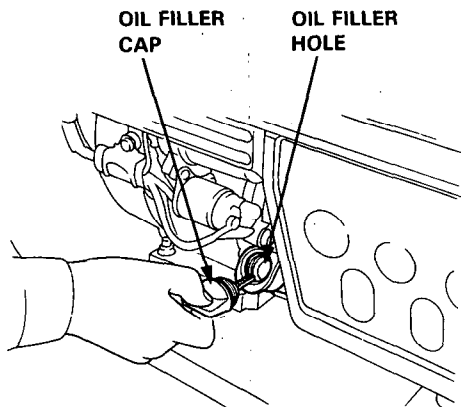

Fuel

Use automotive gasoline with a pump octane number ($\frac{R + M}{2}$) of 86 or higher, or a research octane number of 91 or higher (unleaded is preferred to minimize combustion chamber deposits).

Never use an oil/gasoline mixture or dirty gasoline. Avoid getting dirt, dust or water in the fuel tank.

CAUTION: Gasoline substitutes are not recommended; they may be harmful to the fuel system components.

WARNING

- Gasoline is extremely flammable and explosive under certain conditions. Refuel in a well ventilated area with the engine stopped.
- Do not smoke or allow flames or sparks in the area where the generator is refueled or where gasoline is stored.
- Do not overfill the tank and make sure the filler cap is securely closed after refueling.
- Be careful not to spill fuel when refueling. Fuel vapor or spilled fuel may ignite. If any fuel is spilled, make sure the area is dry before starting the engine.

Fuel tank capacity: 6.0 lit. (12.7 US pt, 10.6 Imp pt)

1. Check the fuel level.
2. If level is low, fill to the shoulder of the fuel filter.
3. After refueling, be sure to tighten the fuel tank cap firmly.

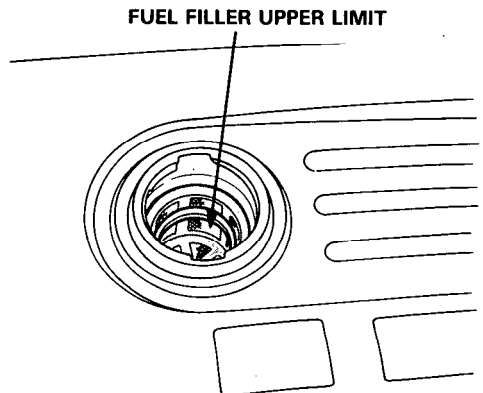
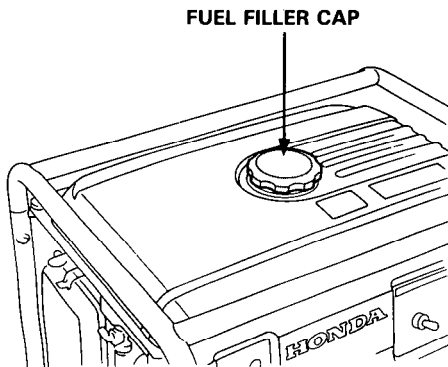

Gasolines Containing Alcohol

If you decide to use a gasoline containing alcohol ("gasohol"), be sure the octane rating is at least as high as that recommended by Honda. There are two types of "gasohol" that containing ethanol, and that containing methanol.

Do not use gasohol that contains more than 10% ethanol. Do not use gasoline containing methanol (methyl or wood alcohol) that does not also contain cosolvents and corrosion inhibitors for methanol. Never use gasoline containing more than 5% methanol, even if it has cosolvents and corrosion inhibitors.

NOTE:

- Fuel system damage or engine performance problems resulting from the use of such fuels are not covered under Power Equipment Warranties. Honda cannot endorse the use of fuels containing methanol since evidence of their suitability is as yet incomplete.
- Before purchasing fuel from an unfamiliar station, try to confirm whether the fuel contains alcohol, and to what percentage. If you notice any undesirable operating symptoms after using a gasoline that contains alcohol, or one that you think contains alcohol, switch to a gasoline that you know does not contain alcohol.

Make sure that the AC circuit breaker is in the OFF position.

The generator may be hard to start if a load is connected.

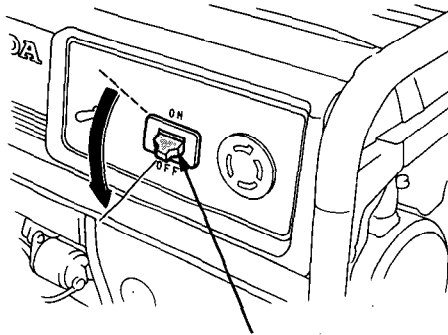

AC CIRCUIT BREAKER

5. STARTING THE ENGINE

1. Turn the fuel valve to the ON position.

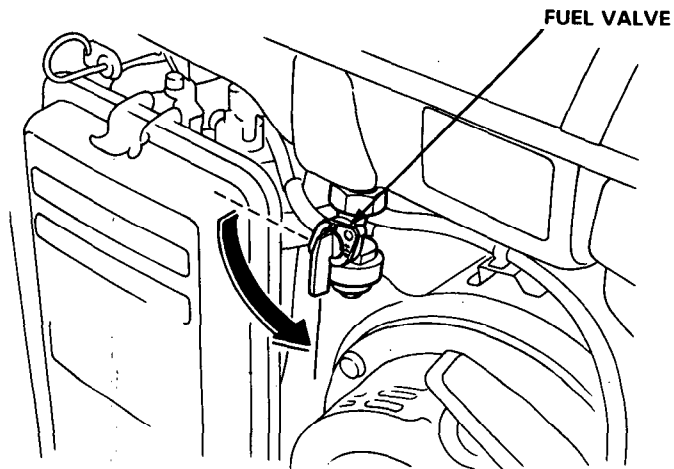

2. Pull the choke rod to the CLOSE position.

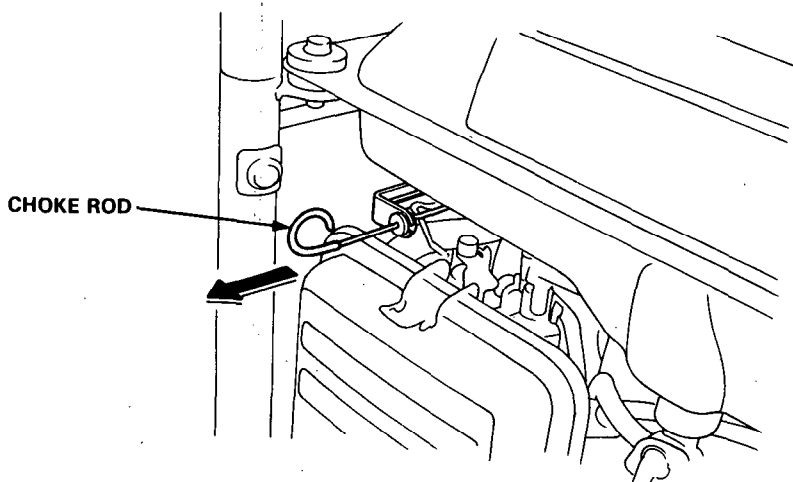

-
3. Make sure the auto-throttle switch is in the OFF position, or more time will be required for warm up.

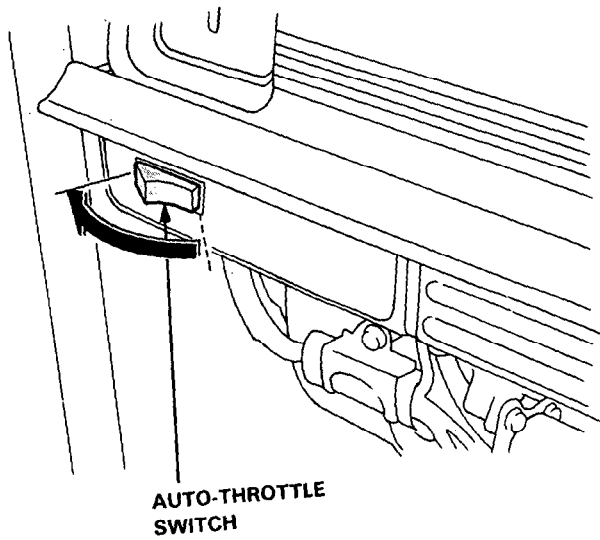

4. Turn the engine switch to the ON position.

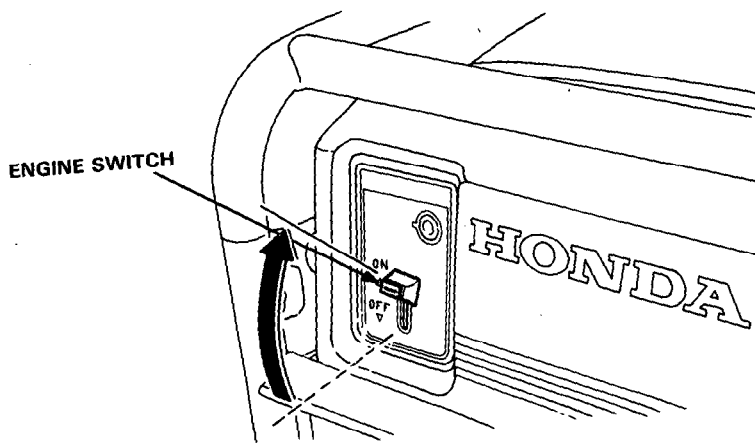

-
5. Pull the starter grip until compression is felt, then pull briskly.

NOTE: Do not allow the starter grip to snap back. Return it slowly by hand.

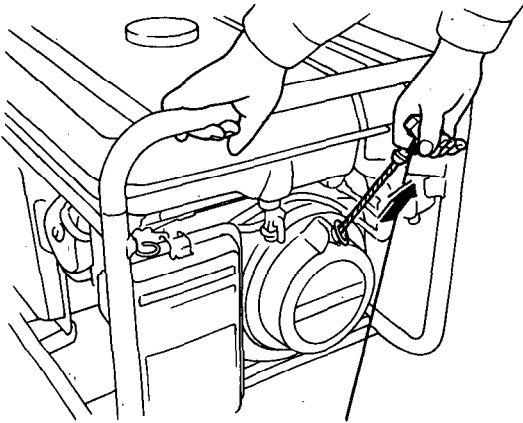

STARTER GRIP

6. Push the choke rod to the OPEN position as the engine warms up.

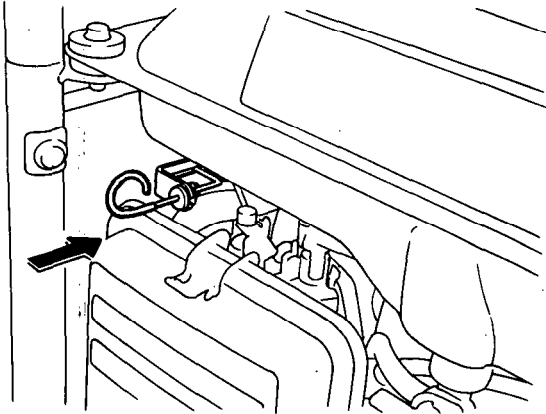

7. If auto-throttle will be used, turn the switch to the "AUTO" position after the engine has warmed up.

6. GENERATOR USE

WARNING To prevent electrical shock from faulty appliances, the generator should be grounded. Connect a length of heavy wire between the ground terminal and the ground source.

CAUTION:

- Limit operation requiring maximum power (3.5KVA) to 30 minutes. For continuous operation, do not exceed the rated power of 3.0 KVA. In either case, the total wattage of all appliances connected must be considered.
- Do not exceed the current limit specified for any one receptacle.
- Connection for emergency power to household circuits must be made by a qualified electrician and must comply with all applicable laws and electrical codes. Improper installation may result in personal injury or damage to equipment or property.

Auto-throttle system

With the switch in the AUTO position, engine speed is automatically reduced to an idle when all loads are turned off or disconnected. When appliances are turned on or reconnected, the engine resumes the rated speed. At OFF, the auto-throttle system does not operate.

NOTE:

- AUTO is recommended to minimize fuel consumption.
- The auto-throttle system will not respond to electrical loads of less than 1 ampere.
- The system is not effective for use with appliance that requires only momentary power. To avoid extended warm-up periods, keep the switch OFF until the engine reaches operating temperature.

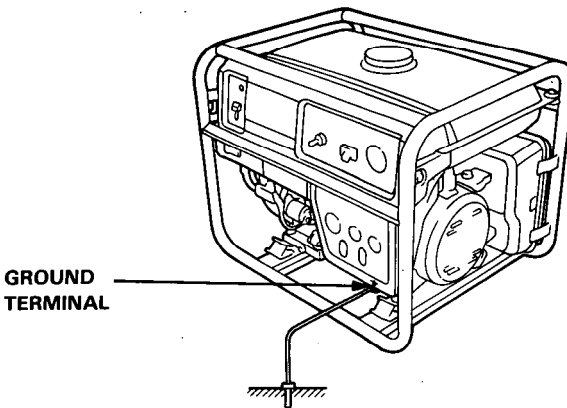

AC applications

1. Turn the voltage selector switch to either position as required. When the switch is turned to "120V ONLY" position, you can use only 120V AC. At "120V/240V" position, you can use both 120V and 240V sources.
2. Switch on the AC Circuit Breaker.
3. Plug in the appliance.

NOTE: This generator is equipped with an AVR (Automatic Voltage Regulator) for stable voltage supply.

CAUTION: Be sure that appliances do not exceed the rated load for more than 30 minutes, and never exceed the maximum load. Substantial overloading will switch off the circuit breaker. Lesser overloading will not switch off the circuit breaker and will shorten the service life of the generator.

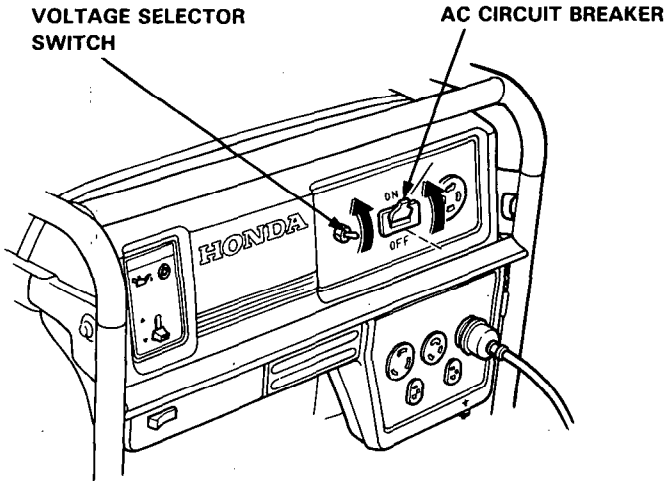

Oil Alert System

The Oil Alert system is designed to prevent engine damage caused by an insufficient amount of oil in the crankcase. Before the oil level in the crankcase can fall below a safe limit, the Oil Alert system will automatically shut down the engine (the engine switch will remain in the ON position).

If the Oil Alert system shuts down the engine, the Oil Alert lamp will flash when you operate the starter, and the engine will not run. If this occurs, add engine oil (p. 8).

OIL ALERT LAMP

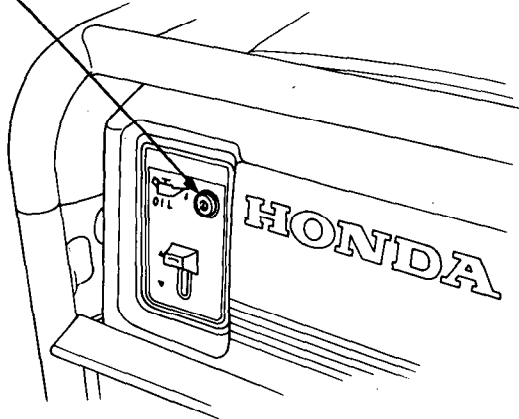

7. STOPPING THE ENGINE

To stop the engine in an emergency, turn the engine switch to the OFF position.

In normal use:

1. Turn the AC circuit breaker to the OFF position.

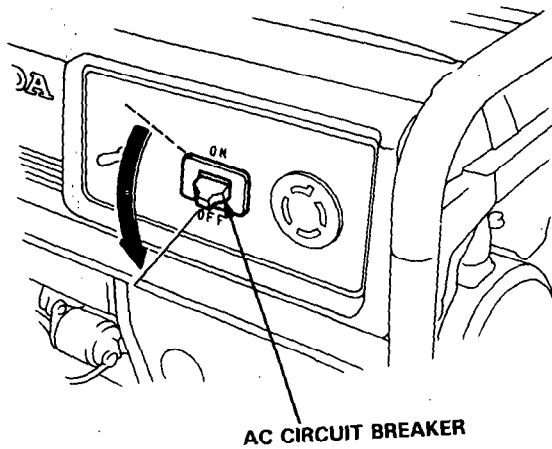

2. Turn the engine switch to the OFF position.

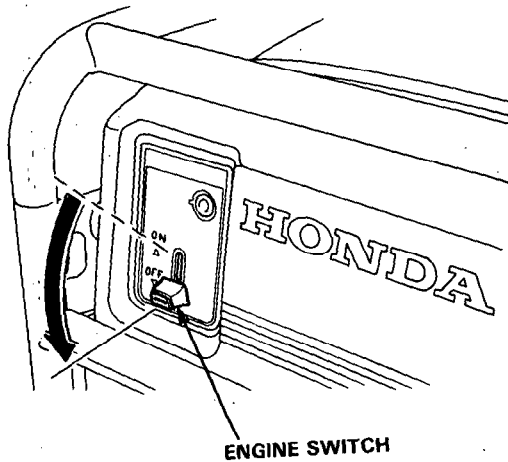

3. Turn the fuel valve to the OFF position.

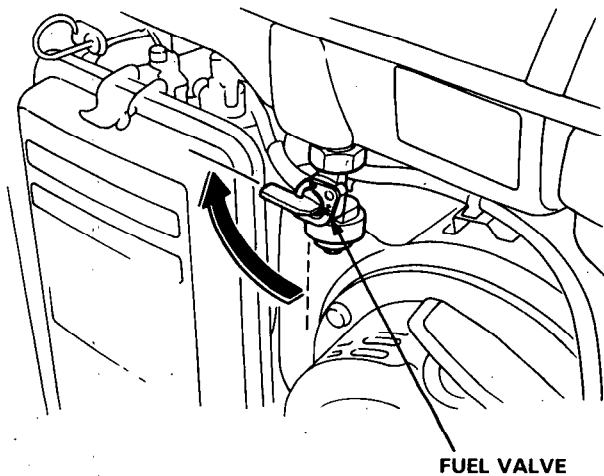

8. MAINTENANCE

The purpose of the maintenance schedule and adjustment is to keep the generator in the best operating condition. Inspect or service as scheduled in the table.

WARNING Shut off the engine before performing any maintenance. If the engine must be run, make sure the area is well ventilated. The exhaust contains poisonous carbon monoxide gas.

CAUTION: Use only genuine HONDA parts or their equivalent. The use of replacement parts which are not of equivalent quality may damage the generator.

Maintenance Schedule

REGULAR SERVICE PERIOD Performed at every indicated month or operating hour interval, whichever comes first.		Each use	First month or 20 Hrs.	Every 3 months or 50 Hrs.	Every 6 months or 100 Hrs.	Every year or 300 Hrs.
ITEM						
Engine oil	Check level	○				
	Change		○		○	
Air cleaner	Check	○				
	Clean			○(1)		
Sediment cup	Clean				○	
Spark plug	Clean-Readjust				○	
Spark arrester	Clean				○	
Valve clearance	Check-Readjust					○(2)
Fuel tank and strainer	Clean					○(2)
Fuel line	Check (Replace if necessary)	Every 3 years (2)				

NOTE: (1): Service more frequently when used in dusty areas.

(2): These items should be serviced by an authorized Honda dealer, unless the owner has the proper tools and is mechanically proficient. See the Honda Shop Manual.

Tool kit

The tools supplied are necessary for performing some periodic maintenance, simple adjustments and repairs.

Always keep the kit with the generator.



10 x 12 mm WRENCH



SCREW DRIVER

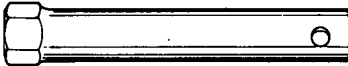

PLUG WRENCH



DRIVER HANDLE



HANDLE BAR

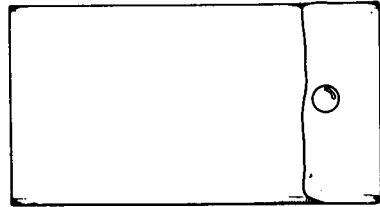

TOOL BAG

Changing oil

Drain the oil while the engine is still warm to assure rapid and complete draining.

1. Remove the drain bolt and filler cap, and drain the oil. Retighten the plug securely.
2. Refill with the recommended oil (see p. 8) and check the level.

ENGINE OIL CAPACITY: 1.1ℓ (1.16 US qt, 1.94 Imp pt)

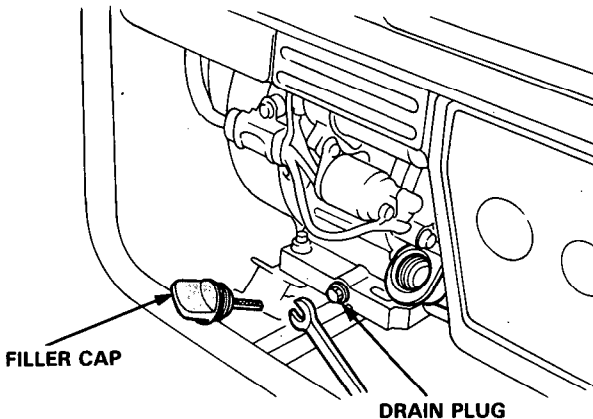

Air cleaner service

A dirty air cleaner will restrict air flow to the carburetor. To prevent carburetor malfunction, service the air cleaner regularly (page 23). Service more frequently when operating the generator in extremely dusty areas.

WARNING Never use gasoline or low flash point solvents for cleaning the air cleaner element. A fire or explosion could result.

CAUTION: Never run the generator without the air cleaner. Rapid engine wear may result.

1. Unsnap the clips, remove the air cleaner cover and remove the element.

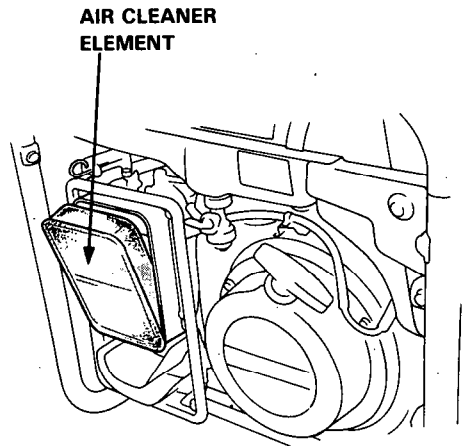
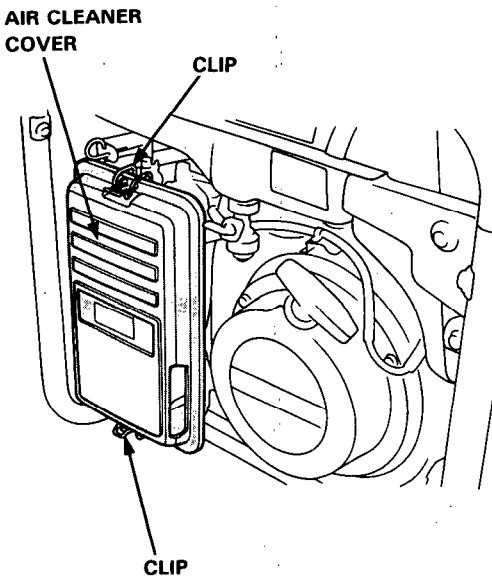

-
2. Wash the element in a non-flammable or high flash point solvent and dry it thoroughly.
 3. Soak the element in clean engine oil and squeeze out the excess oil.
 4. Reinstall the air cleaner element and the cover.

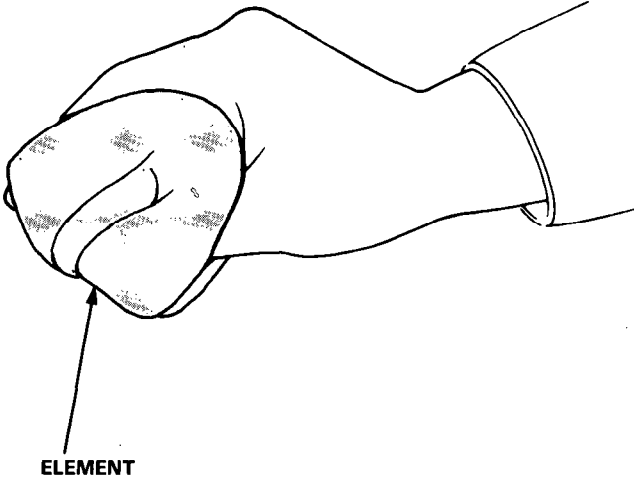

Sediment cup cleaning

Turn the fuel valve to the OFF position. Remove the sediment cup and O-ring, and wash them in nonflammable or high flash point solvent. Dry them thoroughly, and reinstall securely. Turn the fuel valve to the ON position, and check for leaks.

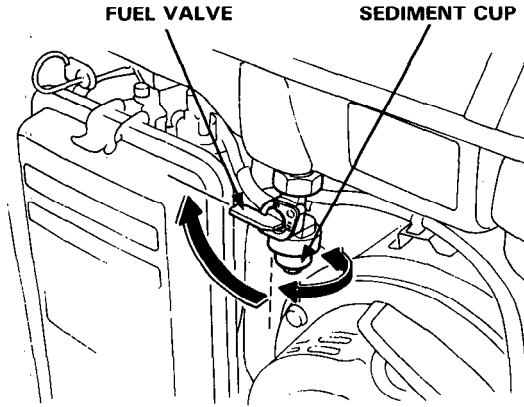

Spark plug service

Recommended spark plug: BPR5ES (NGK) W16EPR-U (ND)

CAUTION: Never use a spark plug of incorrect heat range.

To ensure proper engine operation, the spark plug must be properly gapped and free of deposits.

1. Remove the spark plug cap, and use a spark plug wrench to remove the plug.

WARNING If the engine has been running, the muffler will be very hot. Be careful not to touch the muffler.

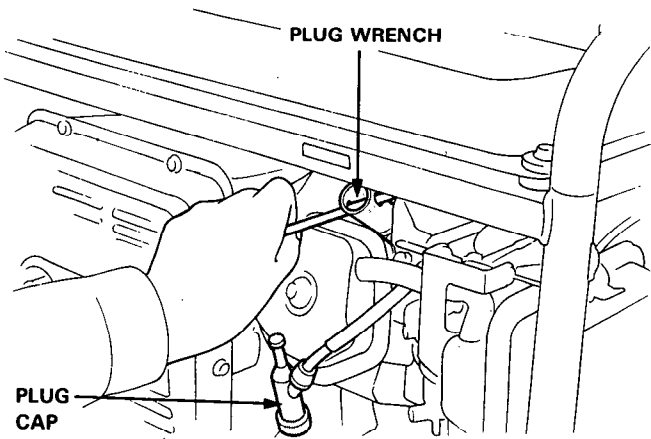

2. Visually inspect the spark plug. Discard it if the insulator is cracked or chipped. Clean the spark plug with a wire brush if it is to be reused.
3. Measure the plug gap with a feeler gauge. The gap should be 0.7–0.8 mm (0.028–0.031 in).

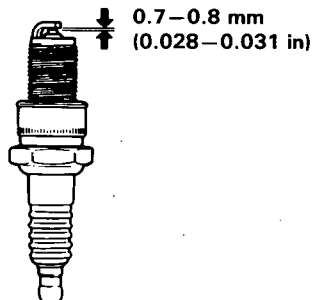

-
4. Check that the spark plug washer is in good condition, and thread the spark plug in by hand to prevent cross-threading.

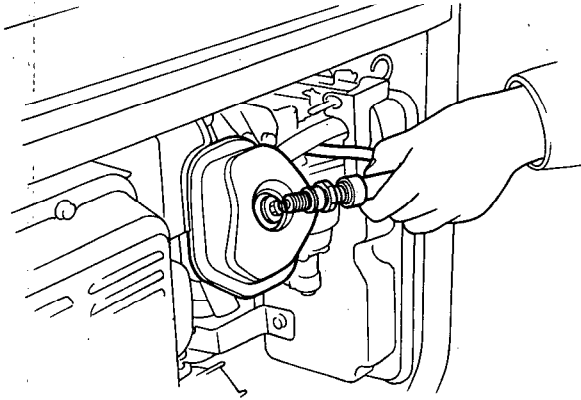

5. After the spark plug is seated, tighten with a spark plug wrench to compress the washer.

NOTE: If installing a new spark plug, tighten $1/2$ turn after the spark plug seats to compress the washer. If reinstalling a used spark plug, tighten $1/8$ – $1/4$ turn after the spark plug seats to compress the washer.

CAUTION: The spark plug must be securely tightened. An improperly tightened spark plug can become very hot and may damage the engine.

Spark arrester maintenance

WARNING If the generator has been running, the muffler will be very hot. Allow it to cool before proceeding.

CAUTION: The spark arrester must be serviced at every 100 hours to maintain its efficiency.

Clean the spark arrester as following:

1. Loosen the screw by the exhaust port of the muffler and remove the spark arrester.
2. Clean the carbon deposit on the spark arrester with a brush.
3. Install the spark arrester in the reverse order of removal.

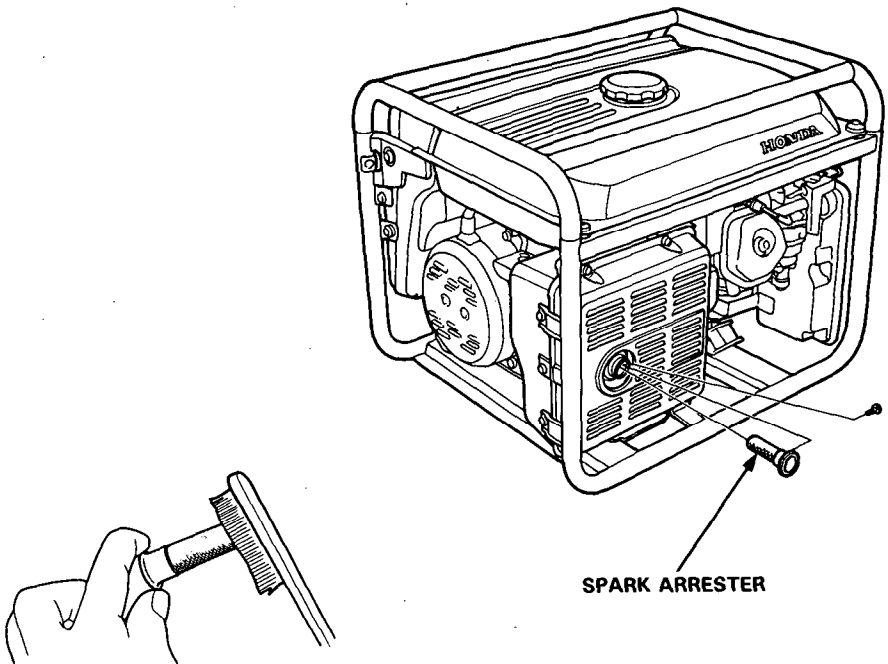

9. TRANSPORTING/STORAGE

WARNING When transporting the engine, turn the fuel valve to the OFF position and keep the engine level to prevent fuel spillage. Fuel vapor or spilled fuel may ignite.

Before storing the unit for an extended period:

1. Be sure the storage area is free of excessive humidity and dust.
2. Drain the fuel —
 - a. With the fuel valve in the OFF position, remove and empty the sediment cup.

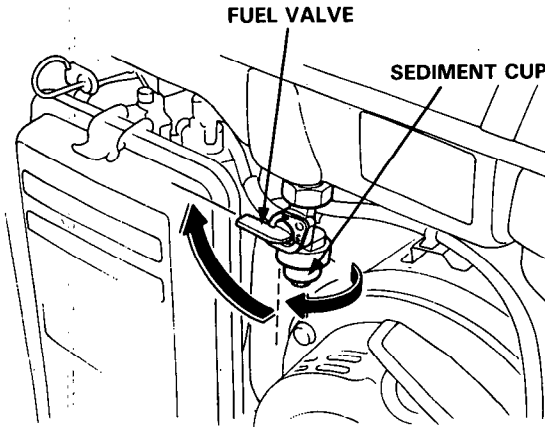

- b. Turn the fuel valve to the ON position and drain the gasoline in the fuel tank into a suitable container.
- c. Replace the sediment cup and tighten securely.

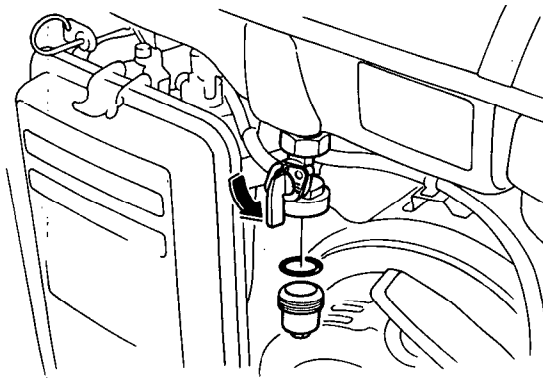

d. Drain the carburetor by loosening the drain screw. Drain the gasoline into a suitable container.

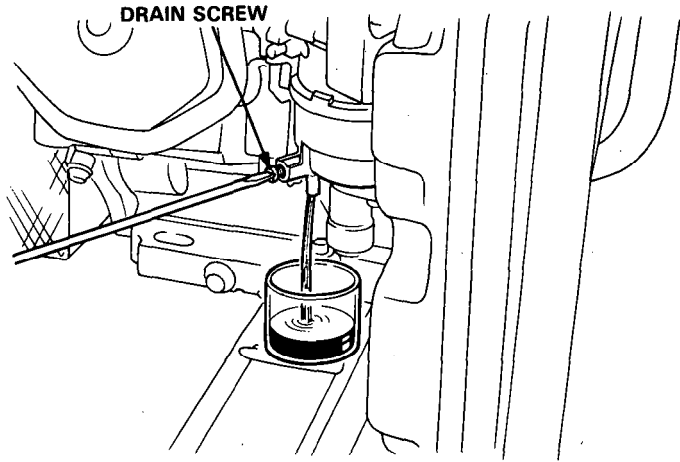

3. Change the engine oil.
4. Remove the spark plug and pour about a tablespoon of clean engine oil into the cylinder. Crank the engine several revolutions to distribute the oil, then reinstall the spark plug.
5. Pull the starter rope slowly until resistance is felt. Continue pulling until the notch on the starter pulley aligns with the hole on the recoil starter (see illustration below). At this point, the intake and exhaust valves are closed, and this will help to protect the engine from internal corrosion.

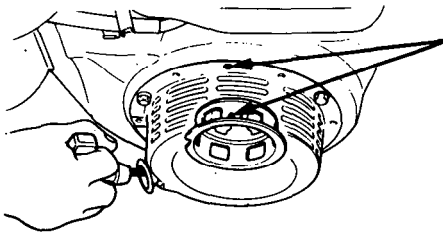

Align the notch on the starter pulley with the hole at the top of recoil starter.

6. Cover the engine to keep out dust.

10. TROUBLESHOOTING

A. When the engine will not start:

1. Is the engine switch on?
2. Does the oil alert lamp flash when the starter is pulled?
3. Is there enough fuel?
4. Are all loads disconnected from the AC receptacles?
5. Is there a spark at the spark plug?
 - a. Remove the spark plug cap. Clean any dust from around the spark plug base, then remove the spark plug.
 - b. Install the spark plug in the plug cap.
 - c. Turn the engine switch on.
 - d. Grounding the side electrode to any engine ground, pull the recoil starter to see if sparks jump across the gap.

⚠ WARNING Be sure there is no spilled fuel near the spark plug. Spilled fuel may ignite. Perform this test in a well ventilated area.

- e. If there are no sparks, replace the plug.
- f. If the new spark plug does not spark, take the generator to an authorized Honda dealer.

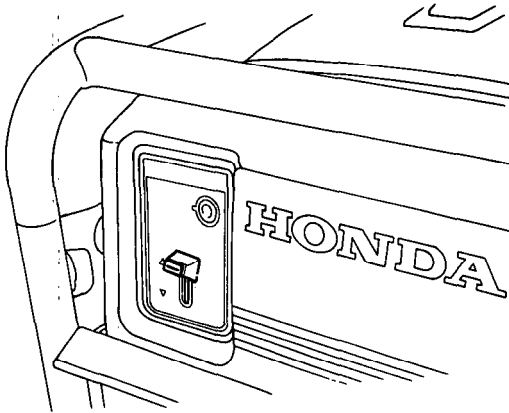

6. Is gasoline reaching the carburetor?

To check, place a suitable container under the drain, turn the engine switch on and loosen the drain screw. Fuel should flow out freely.

If OK, try to start the engine according to the instructions.

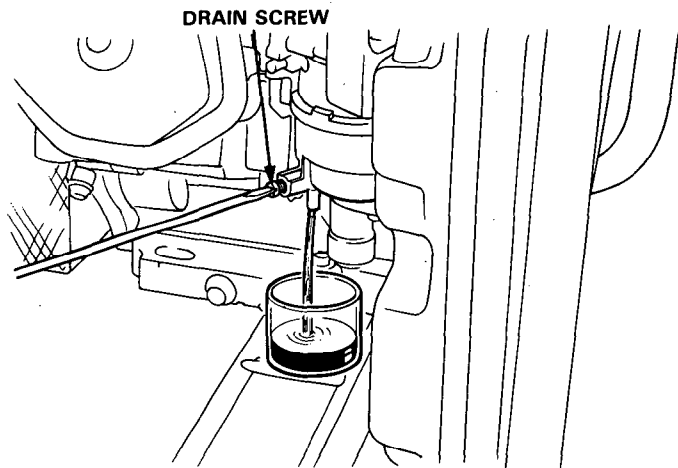

7. If the engine still does not start, take the generator to an authorized Honda dealer.

WARNING If any fuel is spilled, make sure the area around the spark plug and the generator is dry before starting the engine. Fuel vapor or spilled fuel may ignite.

B. When the engine starts but stops immediately;

1. Check the oil alert lamp.

If the oil alert lamp flashes when the starter is pulled, check the engine oil level and fill with the recommended oil.

2. Re-start the engine.

C. No electricity at the AC receptacles:

1. Is the AC circuit breaker on?

2. Check the electrical appliance or equipment for any defects.

11. SPECIFICATIONS

Dimensions

Model	EB3500X
Power equipment description code	EA6
Lenght x Width x Height	605 x 495 x 485 mm (23.8 x 19.5 x 19.1 in)
Dry weight	62 kg (136.7 lb)

Engine

Model	GX240
Engine type	4-stroke, overhead valve, single cylinder
Displacement [Bore x Stroke]	242 cc (14.8 cuin) [73 x 58 mm (2.9 x 2.3 in)]
Max. output	8.0HP/3.600 rpm
Max. torque	1.7 kg-m (12.3 ft-lb)/2.500 rpm
Fuel consumption	230 g/HPH (0.7 lb/HPH)
Cooling system	Forced air
Ignition system	Transistorized magneto
PTO shaft rotation	Counterclockwise

Generator

Model	EB3500X	
Type	A	
AC output	Rated voltage Rated frequency	120/240V 60HZ
	Rated ampere	25/12.5A
	Rated output	3.0KVA (3000W)
	Maximum output	3.5KVA (3000W)

12. WIRING DIAGRAM

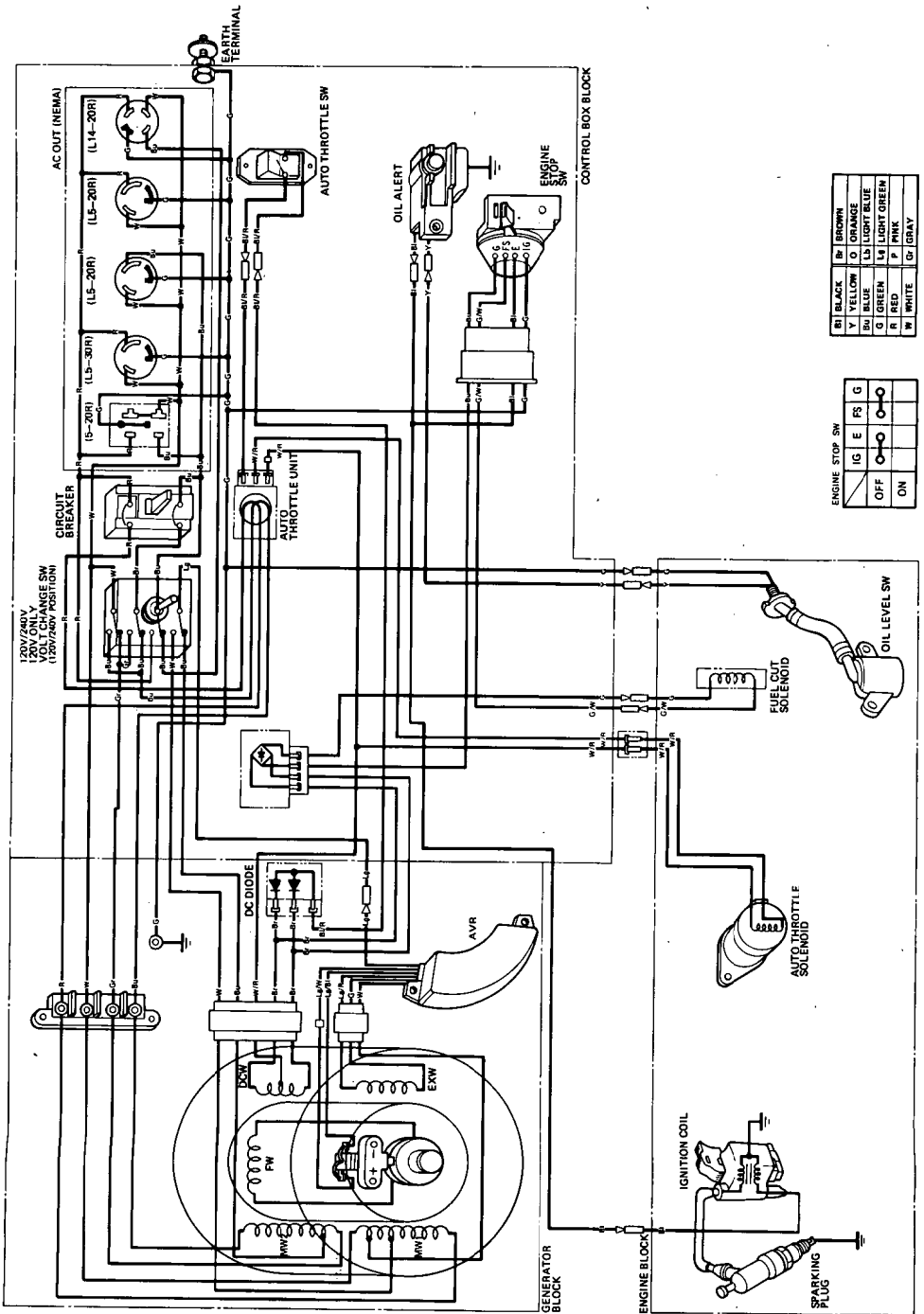

13. HANGER KIT INSTALLATION

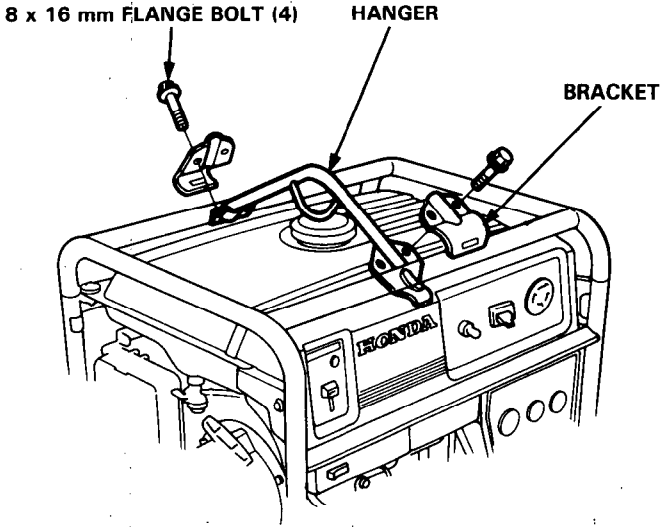

CAUTION:

- Position the hanger at the generator's balance point, in the middle of the fuel tank.
- Fit the end tabs of the hanger through the bracket slots, and bolt the brackets to the hanger.

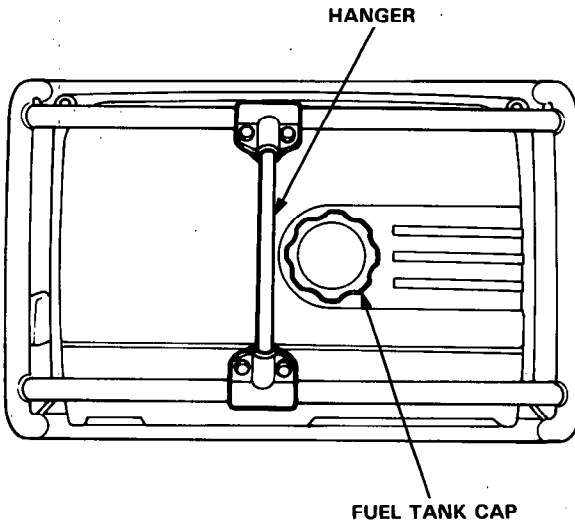

14. INSTALLATION OF OPTIONAL PARTS

4 Wheel Kit Installation

1. Install the four wheels on the axle shaft.
2. Install the axle assembly on the generator using four bolts and nuts.

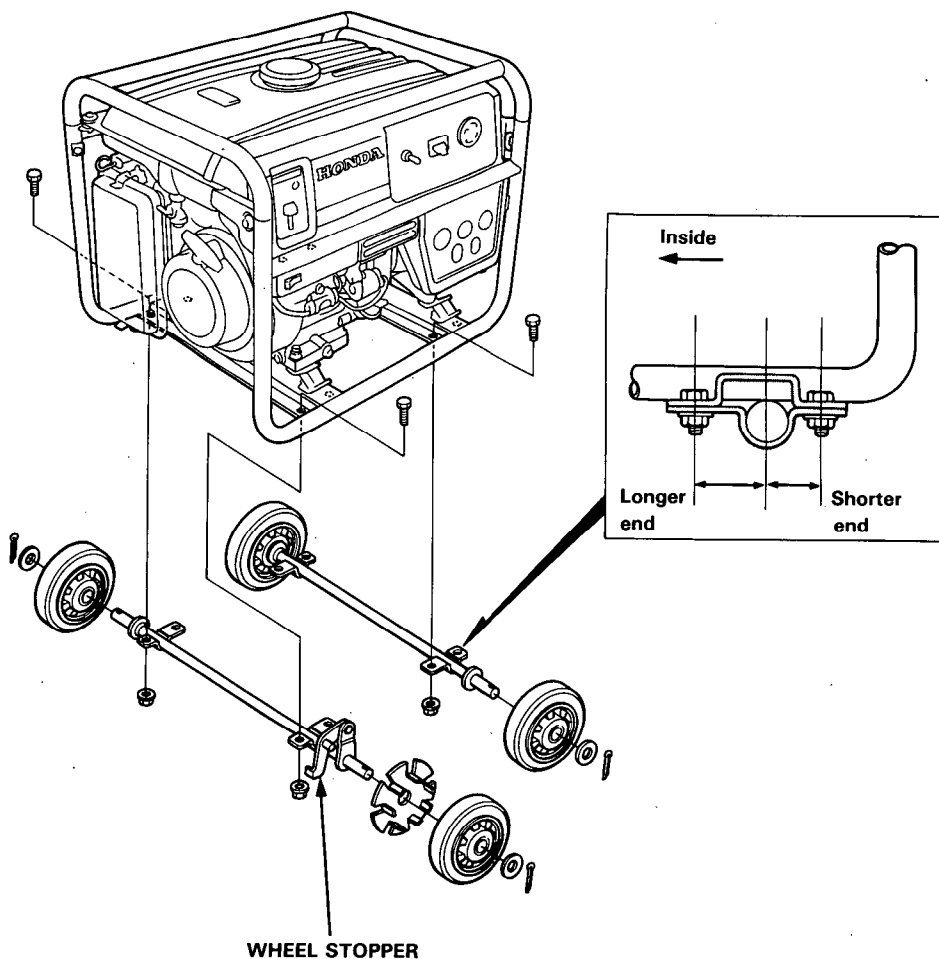

NOTE: Install the shaft with wheel stopper facing engine side.

15. WARRANTY SERVICE

Owner Satisfaction

Your satisfaction and goodwill are important to your dealer and to us. All Honda warranty details are explained in the Distributor's Limited Warranty. Normally, any problems concerning the product will be handled by your dealer's service department. If you have a warranty problem that has not been handled to your satisfaction, we suggest you take the following action:

Normally, any problem concerning the engine will be handled by the dealer's service department. If you have a warranty problem that has not been handled to your satisfaction, we suggest you take the following action:

- Discuss your problem with a member of dealership management. Often complaints can be quickly resolved at that level. If the problem has already been reviewed with the Service Manager, contact the owner of the dealership or the General Manager.
- If your problem still has not been resolved to your satisfaction, contact the Customer Relations Department at the zone office of American Honda Motor Co., Inc. in your area. Zone office locations are shown on the following page. We will need the following information in order to assist you:
 - Your name, address, and telephone number
 - Product model and serial number
 - Date of purchase
 - Dealer name and address
 - Nature of the problem

After reviewing all the facts involved, you will be advised of what action can be taken. Please bear in mind that your problem will likely be resolved at the dealership, using the dealer's facilities, equipment, and personnel, so it is very important that your initial contact be with the dealer.

Your purchase of a Honda generator is greatly appreciated by both your dealer and American Honda Motor Co., Inc. We want to assist you in every way possible to assure your complete satisfaction with your purchase.

Zone Office Locations

NORTHWEST ZONE OFFICE
 (includes Alaska)
 American Honda Motor Co., Inc.
 Customer Relations Department
 PO Box 30285
 Portland, Oregon 97220
 Telephone: (503) 255-1186

MIDWEST ZONE OFFICE
 American Honda Motor Co., Inc.
 Customer Relations Department
 PO Box 22
 Greendale, Wisconsin 53129
 Telephone: (414) 421-9300

NORTHEAST ZONE OFFICE
 American Honda Motor Co., Inc.
 Customer Relations Department
 PO Box 749
 Moorestown, New Jersey 08057
 Telephone: (609) 778-1100

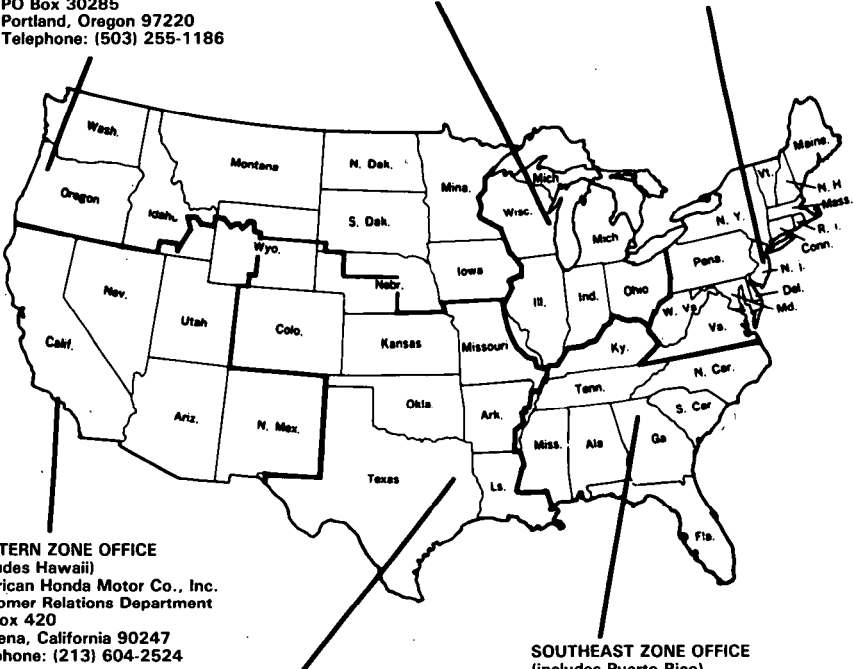

WESTERN ZONE OFFICE
 (includes Hawaii)
 American Honda Motor Co., Inc.
 Customer Relations Department
 PO Box 420
 Gardena, California 90247
 Telephone: (213) 604-2524

SOUTHWEST ZONE OFFICE
 American Honda Motor Co., Inc.
 Customer Relations Department
 PO Box 5406
 Irving, Texas 75062
 Telephone: (214) 258-6883

SOUTHEAST ZONE OFFICE
 (includes Puerto Rico)
 American Honda Motor Co., Inc.
 Customer Relations Department
 1500 Morrison Parkway
 Alpharetta, Georgia 30201
 Telephone: (404) 442-2000

Current customer service contact information:

United States, Puerto Rico, and U.S. Virgin Islands:

Honda Power Equipment dealership personnel are trained professionals. They should be able to answer any question you may have. If you encounter a problem that your dealer does not solve to your satisfaction, please discuss it with the dealership's management. The Service Manager or General Manager can help. Almost all problems are solved in this way.

If you are dissatisfied with the decision made by the dealership's management, contact the Honda Power Equipment Customer Relations Office. You can write:

American Honda Motor Co., Inc.
Power Equipment Division
Customer Relations Office
4900 Marconi Drive
Alpharetta, GA 30005-8847

Or telephone: (770) 497-6400 M-F, 8:30 am - 7:00 pm EST

When you write or call, please provide the following information:

- Model and serial numbers
- Name of the dealer who sold the Honda power equipment to you
- Name and address of the dealer who services your equipment
- Date of purchase
- Your name, address, and telephone number
- A detailed description of the problem

MEMO

MEMO

MEMO

HONDA

31ZB4600
00X31-ZB4-6000



Printed on
Recycled Paper

POM53490

Kinko's 50.2002.05

PRINTED IN U.S.A.