

**HONDA**

**Power**

**Equipment**

**Owner's Manual**  
**Rotary Mower**  
**HRM215**  
**HRB215**

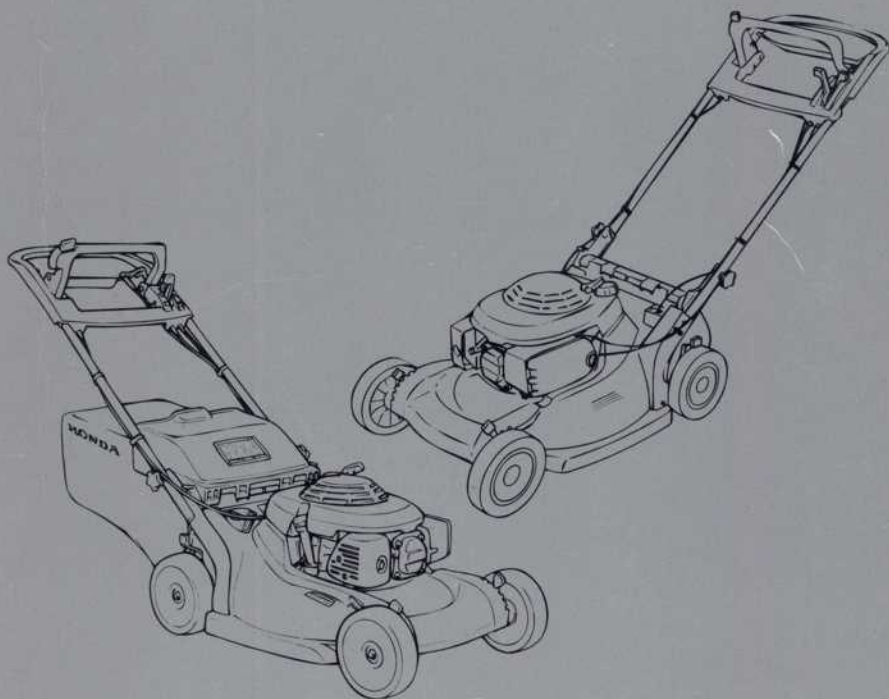

**HONDA**

***Harmony***





This owner's manual is considered a permanent part of the lawn mower and should remain with the mower if resold.

The information and specifications included in this publication were in effect at the time of approval for printing. Honda Power Equipment Mfg., Inc. reserves the right, however, to discontinue or change specifications or design at any time without notice and without incurring any obligation whatever.

Honda lawn mowers meet Consumer Product Safety Commission (CPSC) blade safety requirements for walk-behind rotary mowers.

Your mower is not equipped with a spark arrester, and it may be illegal to operate the mower in some areas. Check local laws and regulations. An optional spark arrester is available from authorized Honda lawn mower dealers.

Congratulations on your selection of a Honda lawn mower. We are certain you will be pleased with your purchase of one of the finest lawn mowers on the market.

We want to help you get the best results from your new mower and to operate it safely. This manual contains the information on how to do that; please read it carefully.

Keep this owner's manual handy, so you can refer to it any time, and make sure the manual stays with the lawn mower if you sell it.

We suggest you read the warranty policy to fully understand its coverage and your responsibilities of ownership. The warranty policy is a separate document that should have been given to you by your dealer.

When your mower needs scheduled maintenance, keep in mind that your Honda lawn mower dealer is specially trained in servicing Honda mowers and is supported by the parts and service divisions of American Honda. Your Honda dealer is dedicated to your satisfaction and will be pleased to answer your questions and concerns.

Best Wishes,  
Power Equipment Division  
American Honda Motor Co., Inc.

## Safety Messages

Your safety and the safety of others is very important. We have provided important safety messages in this manual and on the lawn mower. Please read these messages carefully.

A safety message alerts you to potential hazards that can hurt you and others. Each safety message is preceded by a safety alert symbol  and one of three words: DANGER, WARNING, or CAUTION.

These mean:

 **DANGER**

You **WILL** be **KILLED** or **SERIOUSLY HURT** if you don't follow instructions.

 **WARNING**

You **CAN** be **KILLED** or **SERIOUSLY HURT** if you don't follow instructions.

 **CAUTION**

You **CAN** be **HURT** if you don't follow instructions.

Each message tells you what the hazard is, what can happen, and what you can do to avoid or reduce injury.

---

## Damage Prevention Messages

You will also see other important messages that are preceded by the word **NOTICE**.

This word means:

**NOTICE**

Your lawn mower or other property can be damaged if you don't follow instructions.

The purpose of these messages is to help prevent damage to your lawn mower, other property, or the environment.

# CONTENTS

**Turn to the beginning of each section for a complete list of subjects.**

<b>MOWER SAFETY</b> _____	<b>1</b>
<i>Important information about some specific hazards, and what you can do to prevent injury.</i>	
<b>BLADES AND ATTACHMENTS</b> _____	<b>7</b>
<i>Standard and optional equipment for different lawn care needs.</i>	
<b>CONTROLS</b> _____	<b>11</b>
<i>Identification of components and information about how the controls work.</i>	
<b>BEFORE MOWING</b> _____	<b>19</b>
<i>How to fuel and check your mower to be sure it is ready. How to prepare your lawn and yourself before you begin mowing.</i>	
<b>MOWING</b> _____	<b>29</b>
<i>Starting and stopping the engine, safe mowing practices, and mowing tips.</i>	
<b>TRANSPORTING</b> _____	<b>41</b>
<i>How to load and carry your mower safely.</i>	
<b>MAINTENANCE &amp; ADJUSTMENTS</b> _____	<b>43</b>
<i>When and how to perform routine inspection, service, and adjustments to keep your mower in good operating condition.</i>	
<b>TROUBLESHOOTING</b> _____	<b>61</b>
<i>What to check if you have a problem with your mower.</i>	
<b>STORAGE</b> _____	<b>65</b>
<i>How to protect your mower from rust and corrosion, and ensure that it will start easily when you want to use it again.</i>	
<b>SPECIFICATIONS</b> _____	<b>73</b>
<i>Dimensions, capacities, and other technical information.</i>	
<b>INDEX AND ADDITIONAL INFORMATION</b> _____	<b>77</b>
<i>Index, additional Honda publications, and how to contact us if you have a question or a warranty repair problem.</i>	

# MOWER SAFETY

*This section explains what you need to know to operate your mower safely.*

Safety Information _____	2
Important Message to Parents _____	4
Safety Label Locations _____	5

## MOWER SAFETY

---

### Safety Information

Most accidents with walk-behind mowers can be prevented if you follow all instructions in this manual and on the mower. The most common hazards, according to accident statistics, are discussed below, along with the best way to protect yourself and others.

#### Avoid Rotating Blades

Rotating blades can cause serious cuts and even amputate fingers, hands, toes, or feet. Keep away from the mower deck whenever the engine is running. If you need to work around the deck to clear grass accumulation, adjust the cutting height, or for any other reason, always shut off the engine. Disconnect the spark plug cap from the spark plug. Wear heavy gloves when you need to clean the mower deck or handle the blade(s).

#### Clear Mowing Area

Mower blades can throw rocks and other objects with enough force to cause serious injury. Before mowing, carefully inspect the area and remove all sticks, stones, pieces of wire, and other loose objects. Never operate the blade(s) over gravel.



## Keep Shields in Place

Guards and shields are designed to protect you from being hit by thrown objects and from touching hot engine parts and moving components. For your safety and the safety of others, keep all shields in place when the engine is running.

## Refuel with Care

Gasoline is extremely flammable and gasoline vapor can explode. Refuel only outdoors, in a well-ventilated area, with the engine OFF. If the engine has been running, allow it to cool. Never smoke near gasoline, and keep other flames and sparks away. Always store gasoline in an approved container.

## Wear Protective Clothing

Wearing protective clothing will reduce your risk of injury. Long pants and eye protection reduce the risk of injuries from thrown objects. Sturdy shoes with aggressive soles will help protect your feet and give you better traction on slopes or uneven ground.

## Turn Engine Off When Not Mowing

If you need to leave the mower for any reason, even just to inspect the lawn ahead, always turn the engine off.

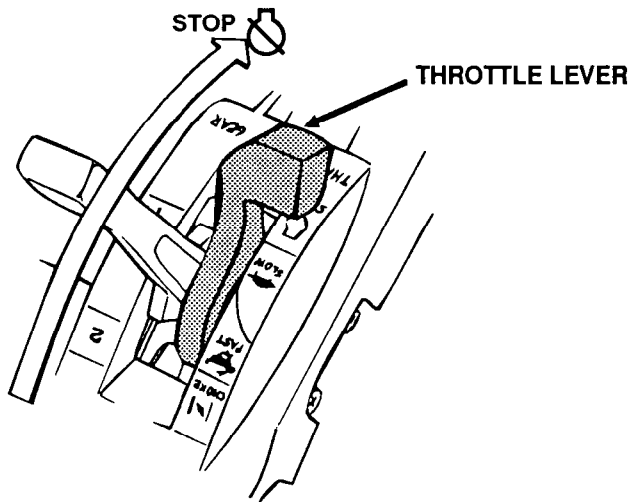



### **Important Message to Parents**

**YOUR CHILDREN'S SAFETY IS VERY IMPORTANT** to Honda. That's why we urge you to read this message before letting your youngster operate this lawn mower. Lawn mowers are tools, not toys. As with any equipment, bad judgments can result in serious injuries. You can help prevent accidents by making good decisions about if, when, and how your youngster operates this equipment.

The first question you'll need to ask is whether your youngster is capable of operating this mower safely. Remember, young people vary widely, and **AGE IS NOT THE ONLY FACTOR**.

Physically, a youngster must be **LARGE ENOUGH AND STRONG ENOUGH** to easily start the mower and control its direction. The youngster also needs enough size, strength, and coordination to comfortably reach and operate the controls.

Another, tougher question you need to ask is if your youngster has enough **MATURITY AND RESPONSIBILITY** to safely operate this mower. Does the young person think through problems and come to logical solutions? Be honest! Anyone who takes unnecessary risks and doesn't obey rules should not operate this lawn mower.

If you decide that your son or daughter can handle the mower safely, **CAREFULLY READ THE OWNER'S MANUAL** with your youngster. Make sure you both understand all instructions and safety information. Also, be sure your youngster wears sturdy shoes and other protective clothing when operating or handling the mower.

**SUPERVISION** is also very important. Walk with your youngster during the first few minutes of mowing. Even after the youngster has become confident with the mower, do not let the young person use the mower without good adult supervision. An adult should also be present during refueling and maintenance. In fact, it's up to parents to make sure that the mower is properly maintained and kept in safe operating condition.

By always placing safety first, your youngster will acquire useful skills and a sense of accomplishment. And you'll both get the best results from your lawn mower.

## Safety Label Locations

The labels shown here contain important safety information. Please read them carefully. These labels are considered permanent parts of your mower. So if a label comes off or becomes hard to read, contact your dealer for a replacement.

### **⚠ CAUTION**

UNDER NORMAL USAGE, THIS BAG MATERIAL IS SUBJECT TO DETERIORATION AND WEAR, AND SHOULD BE CHECKED FREQUENTLY FOR BAG REPLACEMENT. THIS BAG CONFORMS TO A.N.S.I. STANDARD B71.1, ANY REPLACEMENT MUST MEET THIS STANDARD.

### **⚠ WARNING**

Gasoline is highly flammable and explosive and you can be burned or seriously injured. When refueling:

- Keep heat, sparks, and open flame away.
- Fill fuel tank only outdoors.
- Wipe up spills before starting engine.

### **⚠ WARNING**

**MOWER BLADE CAN CUT OFF HANDS OR FEET**

- Stop the engine before opening rear door.
- Always keep feet away from mower deck.

**THROWN OBJECTS CAN CAUSE SERIOUS INJURY, BLINDNESS, OR PROPERTY DAMAGE.**

- Inspect area and remove debris before mowing.
- Keep children and others away.
- Wear eye protection.
- Follow all instructions in your Owner's Manual carefully.



### **⚠ CAUTION**

**HOT MUFFLER CAN BURN YOU.**  
Stay away if engine has been running.

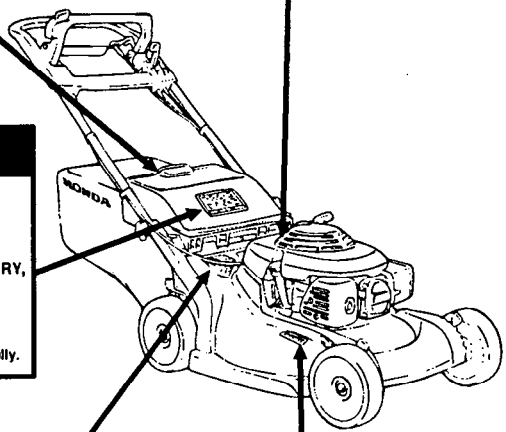



# BLADES AND ATTACHMENTS

*This section shows standard and optional equipment for different lawn care needs, and it tells you how to adapt your mower for bagging, side-discharge and mulching.*

Blades (HRB215 and HRM215) _____	8
Mulching Plug (standard for HRM215) _____	9
Grass Bag (standard for HRB215) _____	9
Side-Discharge Chute (optional for HRB215 and HRM215) _____	10

# BLADES AND ATTACHMENTS

---

## Blades

### HRB215

HRB215 mowers are factory equipped with a high-lift blade for maximum bagging and side-discharge performance.

**ONE-PIECE HIGH-LIFT BLADE**  
(standard for HRB215, optional for HRM215)

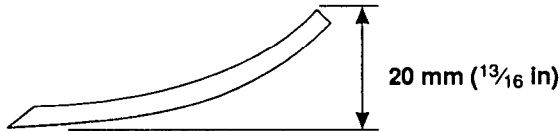

- Best for bagging and side-discharge.
- Less effective for mulching.

### HRM215

HRM215 mowers are factory-equipped with a special two-piece mulching blade assembly.

With the mulching plug installed (page 9), the two blades recirculate cut grass under the mower deck, where the clippings are chopped into small particles that fall through the turf and decompose quickly. This returns nutrients to the soil and reduces the need for raking, bagging, and disposal.

When the mulching plug is removed, and the optional grass bag or side-discharge chute is installed, the blades blow cut grass into the bag or out the side-discharge chute.

It is not necessary to change blades when switching between mulching, bagging, and side-discharge operation. The mulching blades perform all three functions.

**TWO-PIECE MULCHING BLADE ASSEMBLY.**  
(standard for HRM215, optional for HRB215)

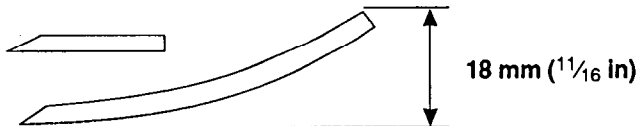

- Best for mulching.
- OK for bagging and side-discharge.

### Grass Bag (standard for HRB215, optional for HRM215)

With the grass bag installed, the lawn mower works like a vacuum cleaner. It blows air through the bag, which traps the clippings.

Bagging should be considered where you want the lawn to be clear of loose particles, such as around swimming pools. Bagging is also a good way to deal with less frequently mowed areas where the grass has grown too tall to mulch easily.

To attach the grass bag, lift the discharge guard, (remove the mulching plug if so equipped), and hook the bag onto the mower deck as shown. Release the discharge guard to secure the grass bag.

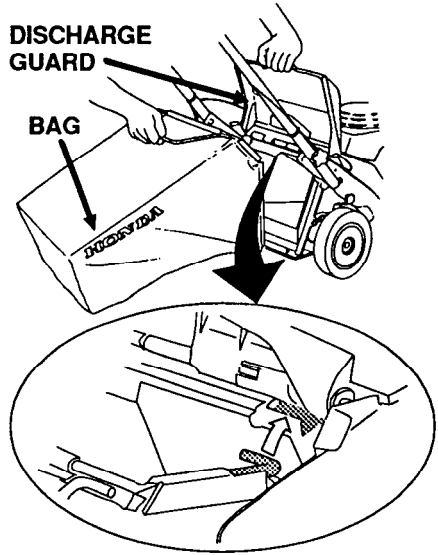

### Mulching Plug (standard for HRM215, optional for HRB215)

The mulching plug contours the mower deck for efficient mulching when the mower is equipped with the two-piece mulching blade assembly (page 8).

You can quickly remove the plug to install a grass bag or side-discharge chute.

Raise the discharge guard to remove or install the mulching plug. When installing, be sure the plug is fully inserted, and the discharge guard is closed.

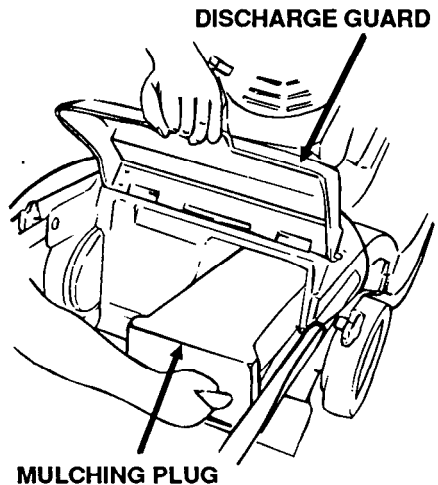

## **BLADES AND ATTACHMENTS**

---

### **Side-Discharge Chute**

(optional for HRB215 and HRM215)

The chute directs grass clippings away from the operator and spreads them over the lawn. The clippings will be larger than mulched particles, and they may need to be removed by raking.

Side-discharge mowing should be considered for less frequently mowed areas where grass has grown too tall to mulch easily.

To attach the chute, lift the discharge guard, (remove the mulching plug if so equipped), and hook the chute onto the mower deck as shown. Release the discharge guard to secure the chute.

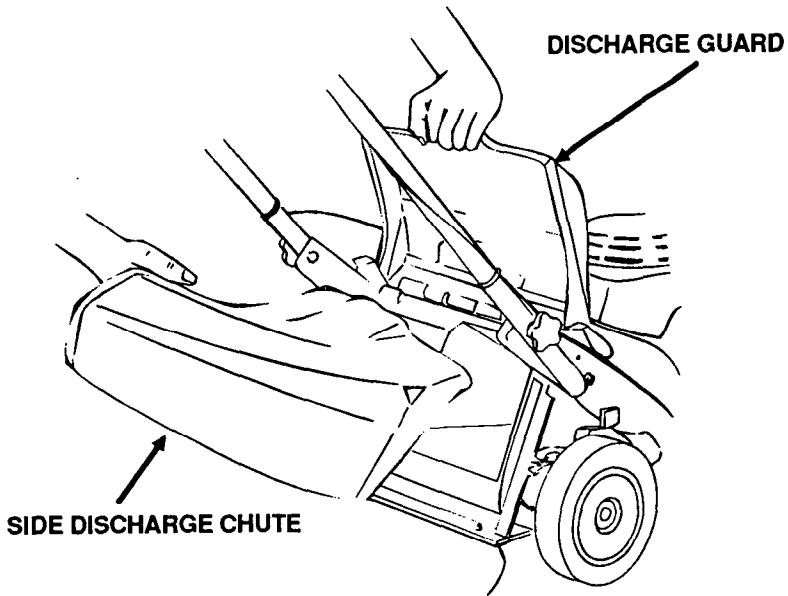

# CONTROLS

*This section shows the locations of controls and other important parts of your mower, and it tells you how the controls work.*

<b>Component Identification</b> _____	<b>12</b>
<b>Controls</b> _____	<b>14</b>
<i>Throttle Lever</i> . . . . .	14
<i>Shift Lever (HRB215SXA &amp; HRM215SXA)</i> . .	14
<i>Blade Control Lever</i> . . . . .	15
<i>Drive Clutch Lever</i> <i>(HRB215SXA &amp; HRM215SXA)</i> . . . . .	16
<i>Handlebar</i> . . . . .	17
<i>Cutting Height Adjustment Levers</i> . . . . .	18



# CONTROLS

---

## Component Identification

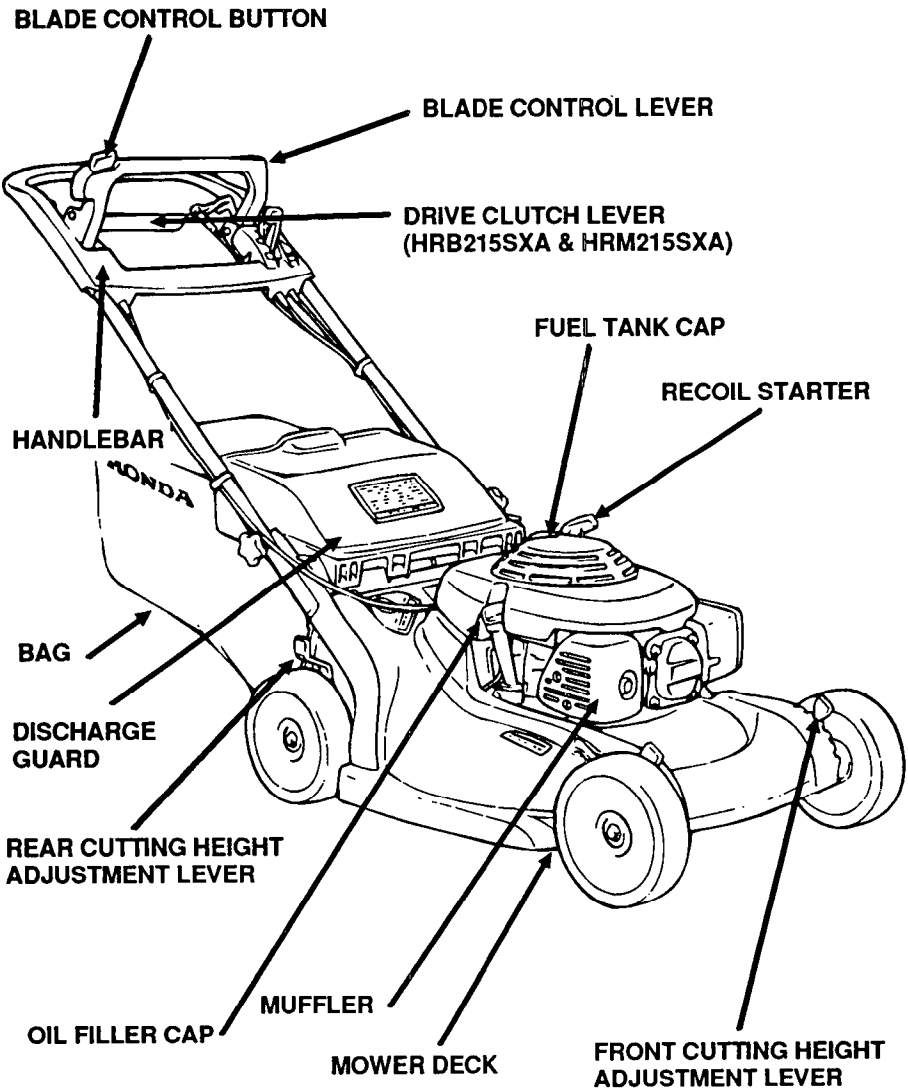

HRB215PXA: Manually propelled, high-lift blade, and grass bag

HRB215SXA: Self-propelled, high-lift blade, and grass bag

HRM215PXA: Manually propelled, mulching blades, and mulching plug

HRM215SXA: Self-propelled, mulching blades, and mulching plug

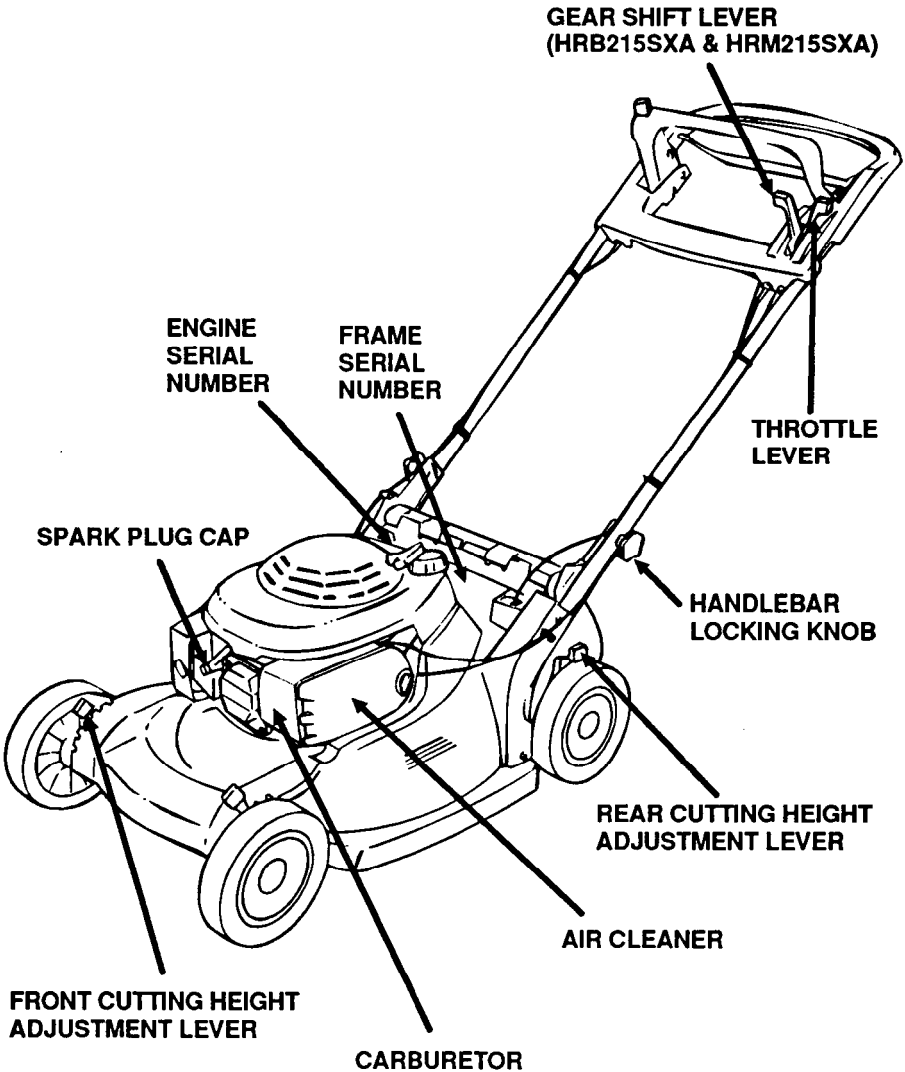

Record the frame and engine serial numbers in the space below. You will need these serial numbers when ordering parts and when making technical or warranty inquiries (see page 83).

**Frame serial number: MZB** \_ \_ \_ \_ \_





**Engine serial number: GJAB** - \_ \_ \_ \_ \_

## CONTROLS

---

### Controls

#### Throttle Lever

-  **CHOKE** – For starting a cold engine.
-  **FAST** – For restarting a warm engine and for mowing.
-  **SLOW** – For idling the engine.
-  **STOP** – For stopping the engine and closing the fuel valve.

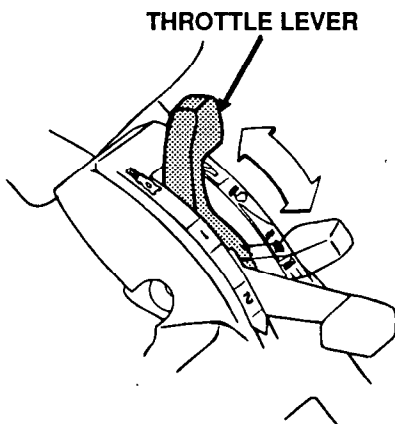

When the mower is not in use, leave the throttle lever in the STOP position to prevent carburetor flooding and to reduce the possibility of fuel leakage.

#### Gear Shift Lever (HRB215SXA & HRM215SXA)

- 1 (slow)** – For mowing thick grass or maneuvering in small areas.
- 2 (fast)** – For maximum self-propelled speed in large, open areas.

To avoid incomplete gear engagement, move the gear shift lever all the way forward or all the way back.

You can shift gears without releasing the drive clutch lever (page 16), but the transmission may not shift smoothly if the mower is pulling hard. For smoother operation, release the drive clutch lever before shifting gears.

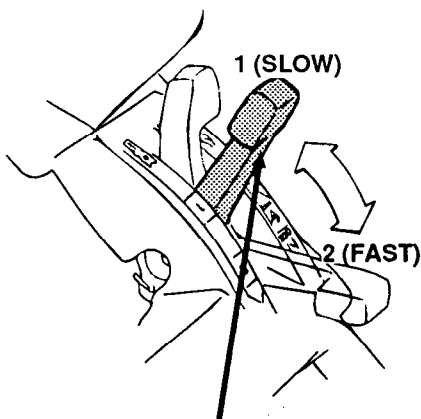

**GEAR SHIFT LEVER  
(HRB215SXA & HRM215SXA)**

## Blade Control Lever

The blade control lever starts and stops blade rotation.

To start blade rotation, press the button on top of the blade control lever, then pull the lever back and hold it against the handlebar.

Release the blade control lever to stop the blade.

Operate the blade control lever with a quick and complete motion, so the blade drive is always either fully engaged or stopped. This will help to prevent stalling the engine, and it will also extend the service life of the blade control mechanism.

Always release the blade control lever before starting the engine to prevent the blade(s) from turning.

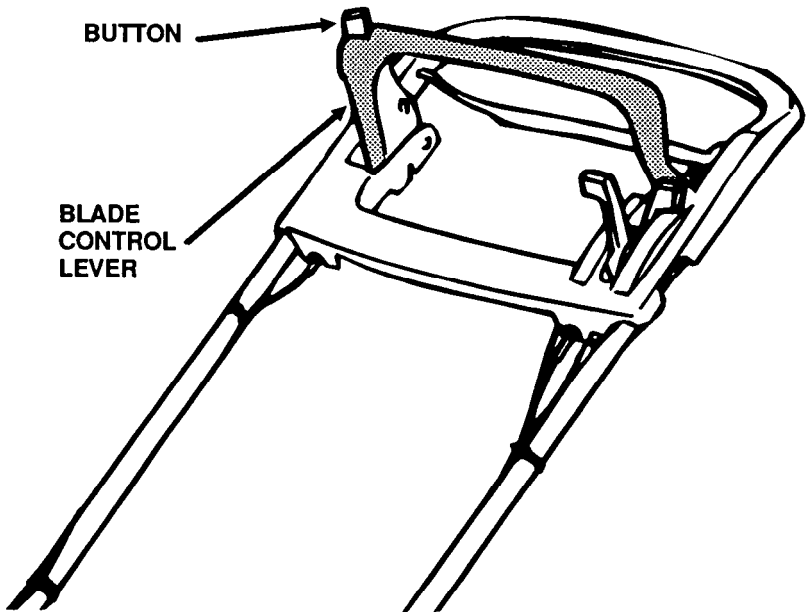

## CONTROLS

---

### Drive Clutch Lever (HRB215SXA & HRM215SXA)

The drive clutch lever engages and disengages the transmission that drives the rear wheels.

To propel the mower, move the drive clutch lever up and hold it against the handlebar.

Release the drive clutch lever to stop the mower.

Operate the drive clutch lever with a quick and complete motion, so the drive clutch is always either fully engaged or released. This will help to extend the service life of the clutch mechanism.

For self-propelled mowing, press the button on top of the blade control lever, pull the blade control lever back, then move the drive clutch lever up against the handlebar. Hold both levers against the handlebar.

Always release the drive clutch lever before starting the engine. If the drive clutch is engaged, the mower will move forward when you operate the starter.

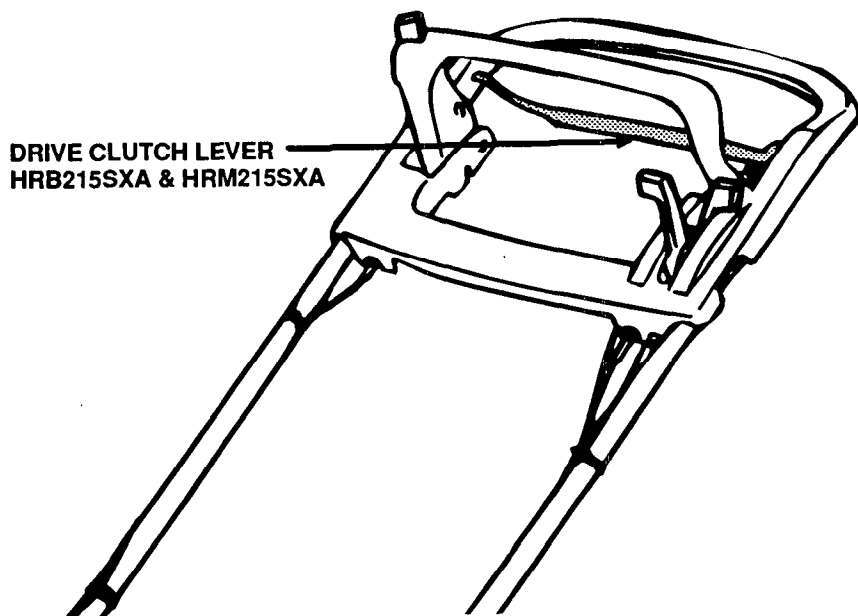

## Handlebar

The handlebar is adjustable to a high, mid, or low position. Select the height that provides the most comfortable operating position.

1. Loosen the handlebar locking knobs.
2. Spread the lower ends of the handlebar to release the locating pins.
3. Move the handlebar up or down, so the locating pins engage other holes on the handlebar mounting brackets.

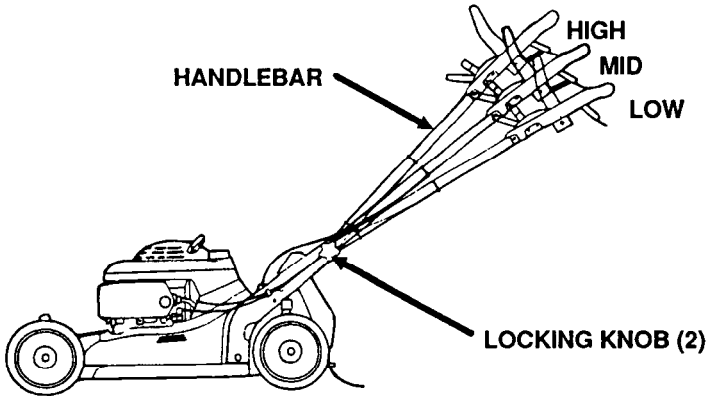

4. Tighten the handlebar locking knobs securely.  
The handlebar can be folded for compact storage or transport.
5. Loosen the handlebar locking knobs.
6. Spread the lower ends of the handlebar struts to release the locating pins.
7. Fold the handlebar forward, over the top of the mower.

When folding the handlebar, be careful to avoid kinking or pinching the control cables.

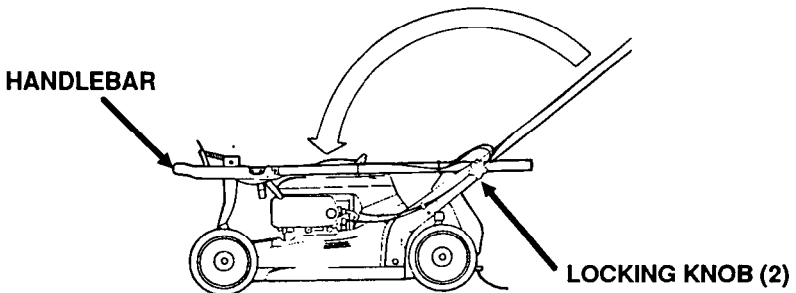

# CONTROLS

## Cutting Height Adjustment Levers

There are six settings to choose from, as shown in the illustration. The cutting height figures are approximate, as the actual height of cut grass will vary with lawn and soil conditions.

To adjust cutting height, pull each adjustment lever toward the wheel, and move it into another notch. Set all four adjustment levers to the same cutting height position.

ADJUSTMENT LEVERS

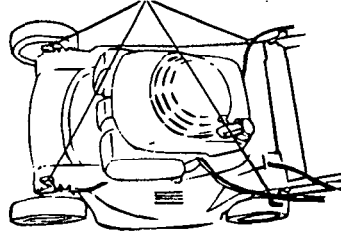

ADJUSTMENT LEVER

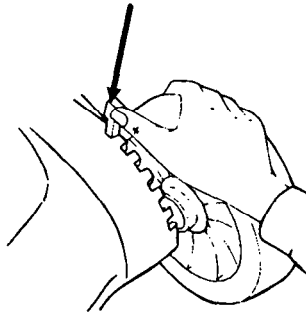

### **⚠ WARNING**

The blades will start spinning if the blade control lever is pulled back while the engine is running.

Spinning blades can cut you severely and can amputate fingers and toes.

Stop the engine before placing your hands near the mower

If you are not sure what cutting height to select, check the appearance of the lawn after mowing a small area, then readjust the cutting height if necessary.

Cutting Height	
HRM215	HRB215
25 mm (1 in)	19 mm (3/4 in)
38 mm (1 1/2 in)	25 mm (1 in)
51 mm (2 in)	38 mm (1 1/2 in)
64 mm (2 1/2 in)	51 mm (2 in)
76 mm (3 in)	64 mm (2 1/2 in)

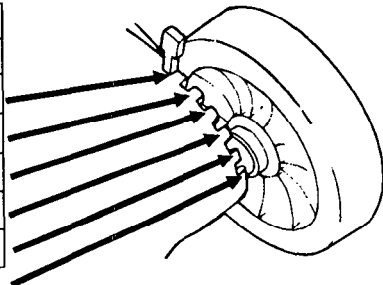

# BEFORE MOWING

*This section explains how to fuel and check your mower to be sure it is ready, and it tells you how to prepare your lawn and yourself before you begin mowing.*

<b>Check Your Lawn</b> _____	<b>20</b>
<b>Check Your Mower</b> _____	<b>21</b>
<i>Blade(s)</i> . . . . .	21
<i>Engine Oil</i> . . . . .	22
<i>Fuel</i> . . . . .	23
<i>Air Cleaner</i> . . . . .	26
<i>Grass Bag</i> <i>(standard for HRB215, optional for HRM215)</i> .	27
<i>Handlebar Height</i> . . . . .	27
<i>Cutting Height</i> . . . . .	27
<i>Are YOU Ready to Mow?</i> . . . . .	28



## BEFORE MOWING

---

### Check Your Lawn

For your safety and for the safety of others, always inspect the area before mowing.

### Objects

Anything which can be picked up by the blades and thrown is a potential hazard to you and others. Look for things like stones, sticks, bones, and wire. Remove them from the mowing area.

### People and Pets

People and animals near the mowing area can move into your path or into a position where they could be struck by thrown objects. Clear the area of people and pets, especially children. Their safety is your responsibility.

### Lawn

Check the length and condition of the grass, so you will know what cutting height and mowing speed to use.

Avoid mowing wet grass. Not only will wet grass clog your mower deck and collect in clumps on the lawn, it also gives poor traction, increasing your risk of losing your footing.



## Check Your Mower

### Blade(s)

With the throttle lever in the STOP position and the spark plug cap disconnected, tilt the mower to the right, so the carburetor side is up. This will help to prevent fuel leakage and hard starting.

Inspect the blade(s) for wear and damage.

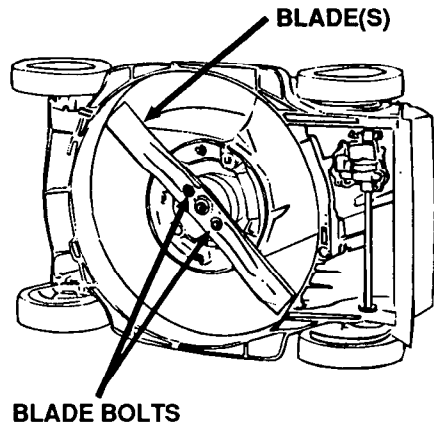

**NORMAL**



**EXCESSIVELY  
WORN**



**BENT**



**CRACKED**

Dull blades can be sharpened, but blades that are worn out, bent, cracked, or otherwise damaged must be replaced. Worn or damaged blades can break, causing blade pieces to be thrown from the mower.

When the blade(s) needs sharpening or replacement take the lawn mower to an authorized Honda lawn mower dealer. Or, if you have a torque wrench, you can remove and install the blade(s) yourself (see pages 58 - 59).

**BLADE SHARPENING:** To avoid weakening the blade(s), or causing imbalance or poor cutting, the blade(s) should be sharpened by trained staff at an authorized Honda lawn mower dealer.

**BLADE REPLACEMENT:** Use genuine Honda replacement blades or their equivalent.

Check that the blade bolts are tight. Use a wooden block to prevent the blade(s) from turning when tightening the bolts. Wear heavy gloves to protect your hands.

**Blade bolt torque: 49 - 59 N·m (5.0 - 6.0 kg·m, 36 - 43 ft·lb).**

## BEFORE MOWING

### Engine Oil

Check the engine oil level with the engine stopped and the mower on a level surface.

1. Remove the oil filler cap, and wipe the dipstick clean.
2. Insert and remove the dipstick without screwing it into the filler neck. Check the oil level shown on the dipstick.
3. If the oil level is low, add oil to reach the upper limit mark on the dipstick. Do not overfill.

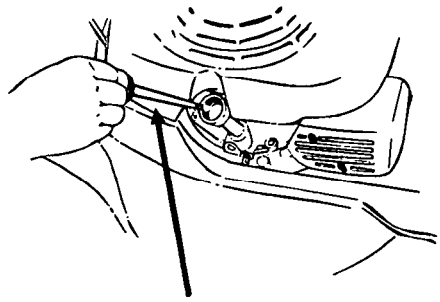

FILLER CAP/DIPSTICK

#### NOTICE

Running the engine with a low oil level can cause engine damage.

Use high-detergent, premium quality 4-stroke engine oil, certified to meet or exceed U.S. automobile manufacturers' requirements for API Service Classification SG, SF/CC, CD.

#### NOTICE

Using nondetergent oil can shorten the engine's service life, and using 2-stroke oil can damage the engine.

SAE 10W-30 is recommended for general, all-temperature use. Other viscosities shown in the chart may be used when the average temperature in your area is within the indicated range.

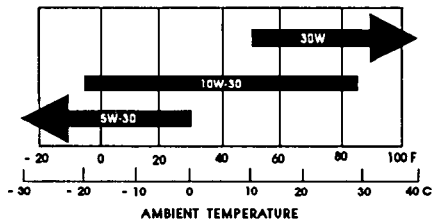
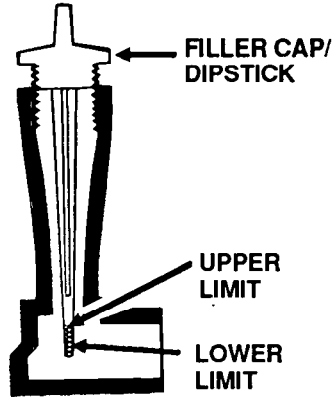

4. After checking the engine oil level, screw in the filler cap/dipstick securely.

## Fuel

**Fuel tank capacity: 1.0 / (0.26 US gal)**

Refuel in a well-ventilated area before starting the engine. If the engine has been running, allow it to cool.

Remove the tank cap and check the fuel level. Refill the tank if the fuel level is low. Refuel carefully to avoid spilling fuel. Do not overfill; there should be no fuel in the filler neck. After refueling, tighten the fuel tank cap securely.

### **! WARNING**

Gasoline is highly flammable and explosive.

You can be burned or seriously injured.

When refueling:

- Stop the engine and keep heat, sparks, and flames away.
- Refuel only outside.
- Wipe up spills immediately.

Never refuel the mower inside a building where fumes may reach flames or sparks. Keep gasoline away from appliance pilot lights, barbecue, electric appliances, power tools, etc.

Spilled fuel is not only a fire hazard, it causes environmental damage. Wipe up spills immediately. Dispose of gasoline properly.

#### **NOTICE**

Fuel can damage paint and plastic. Be careful not to spill fuel when filling your fuel tank. Damage caused by spilled fuel is not covered under warranty.

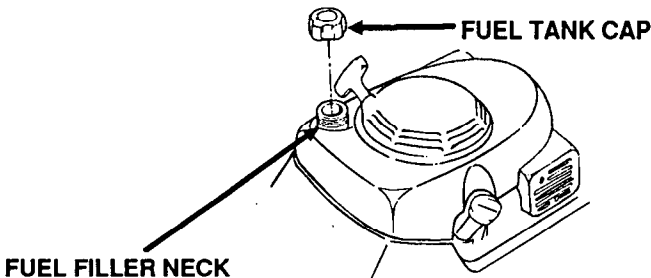

## **BEFORE MOWING**

---

### **Fuel Recommendations**

**Use gasoline with a pump octane rating of 86 or higher.**

We recommend unleaded fuel because it produces fewer engine and spark plug deposits and extends exhaust system life.

Never use stale or contaminated gasoline or an oil/gasoline mixture. Avoid getting dirt or water in the fuel tank.

Occasionally you may hear light “spark knock” or “pinging” (metallic rapping noise) while operating under heavy loads. This is no cause for concern.

If spark knock or pinging occurs at a steady engine speed, under normal load, change brands of gasoline. If spark knock or pinging persists, see an authorized Honda lawn mower dealer.

<b>NOTICE</b>
---------------

Running the engine with persistent spark knock or pinging can cause engine damage.

Running the engine with persistent spark knock or pinging is misuse, and the Distributor's Limited Warranty does not cover parts damaged by misuse.

## Oxygenated Fuels

Some conventional gasolines are being blended with alcohol or an ether compound. These gasolines are collectively referred to as oxygenated fuels. Some areas of the United States and Canada use oxygenated fuels to help reduce emissions.

If you use an oxygenated fuel, be sure it is unleaded and meets the minimum octane rating requirement.

Before using an oxygenated fuel, try to confirm the fuel's contents. Some states/provinces require this information to be posted on the pump.

The following are the EPA approved percentages of oxygenates:

- **ETHANOL** (ethyl or grain alcohol) 10% by volume  
You may use gasoline containing up to 10% ethanol by volume. Gasoline containing ethanol may be marketed under the name "Gasohol".
- **MTBE** (Methyl Tertiary Butyl Ether) 15% by volume  
You may use gasoline containing up to 15% MTBE by volume.
- **METHANOL** (methyl or wood alcohol) 5%  
You may use gasoline containing up to 5% methanol by volume, as long as it also contains cosolvents and corrosion inhibitors to protect the fuel system. Gasoline containing more than 5% methanol by volume may cause starting and/or performance problems. It may also damage metal, rubber, and plastic parts of your fuel system.

If you notice any undesirable operating symptoms, try another service station, or switch to another brand of gasoline.

Fuel system damage or performance problems resulting from the use of an oxygenated fuel containing more than the percentages of oxygenates mentioned above are not covered under warranty.

## BEFORE MOWING

---

### Air Cleaner

Check that the air filters are clean and in good condition. Dirty air filters will restrict air flow to the carburetor, reducing engine performance.

#### NOTICE

Operating the engine without filters, or with damaged filters, will allow dirt to enter the engine, causing rapid engine wear. This type of damage is not covered by the Distributor's Limited Warranty.

1. Unscrew and remove the air cleaner cover knob, then remove the cover.
2. Inspect the paper filter. Remove and inspect the foam filter. Replace damaged filters. Clean or replace dirty filters. See page 48 for cleaning instructions.
3. Reinstall the filters and cover. Tighten the cover knob securely.

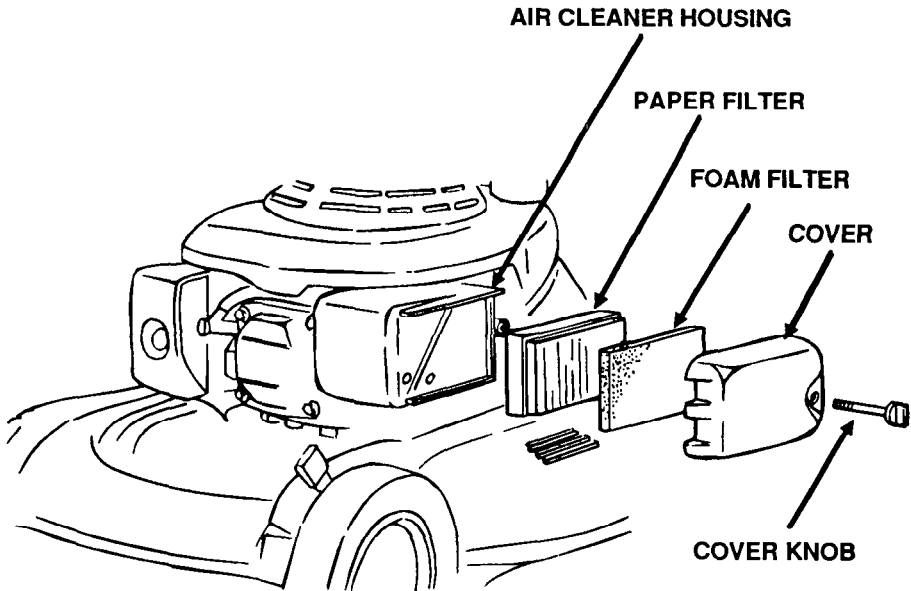

## Grass Bag (standard for HRB215, optional for HRM215)

Check the condition of the grass bag. The grass bag wears during normal use and will eventually require replacement. Grass bag replacement is explained on page 60.

### **⚠ WARNING**

Objects hit by the blade can be thrown through a worn or damaged grass bag.

Thrown objects can seriously injure you.

Replace the grass bag if worn or damaged.

Check that the grass bag is not clogged. A clogged bag will not collect grass efficiently and must be cleaned. When the bag needs cleaning, wash it with a garden hose, and allow it to dry completely before use; a wet bag will clog quickly.

## Handlebar

Check that the handlebar is adjusted to a comfortable operating position. Handlebar height adjustment is explained on page 17.

## Cutting Height

Check the mower deck cutting height settings, and be sure that all four adjustment levers are set to the same cutting height position. Cutting height adjustment is explained on page 18.

### **⚠ WARNING**

The blades will start spinning if the blade control lever is pulled back while the engine is running.

Spinning blades can cut you severely and can amputate fingers and toes.

Stop the engine before placing your hands near the mower deck.

**ADJUSTMENT LEVERS**

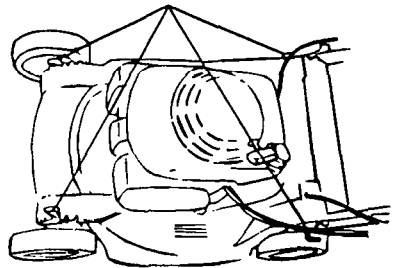



## **BEFORE MOWING**

---

### **ARE YOU Ready to Mow?**

Just in case you have missed a hidden object in your lawn, be sure to wear protective clothing. Long pants and eye protection can lower your risk of injury from thrown objects. Wear footwear that protects your feet and won't let you slip if you mow on slopes or uneven ground.

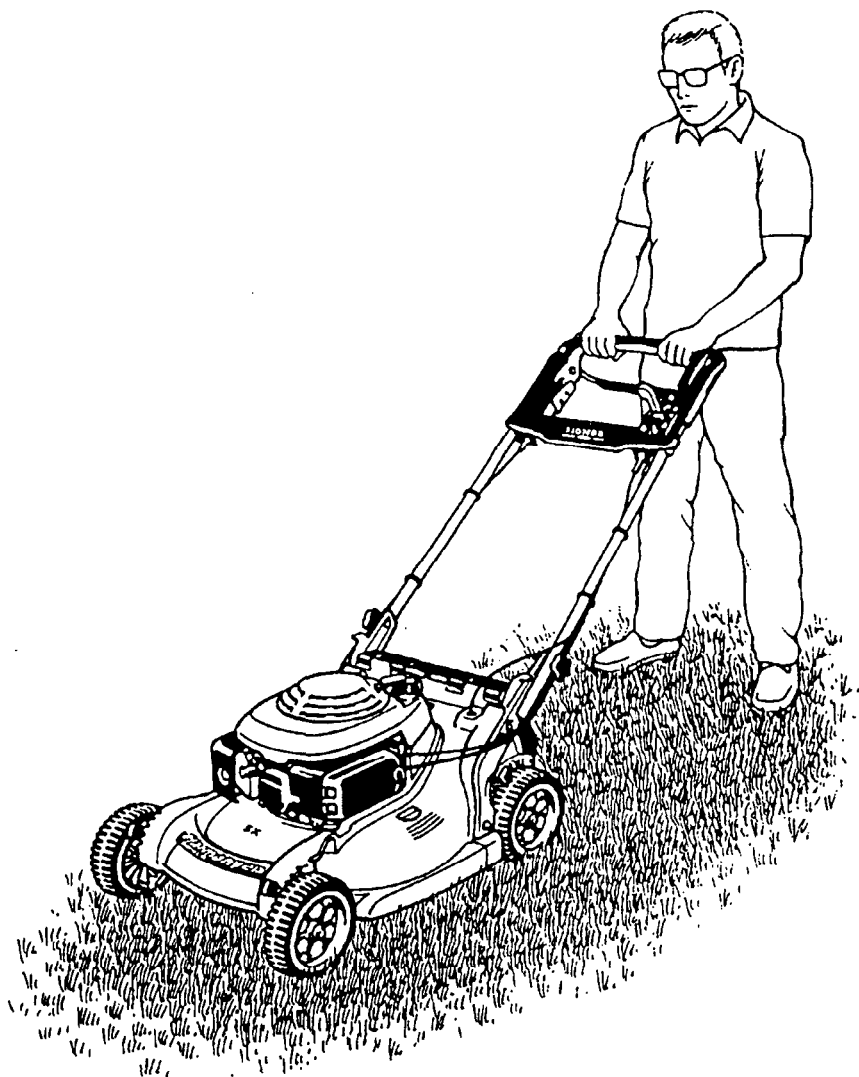

# MOWING

*This section tells you how to operate the mower safely and effectively.*

<b>Starting the Engine</b> _____	<b>30</b>
<b>Operating the Controls for Mowing</b> _____	<b>31</b>
<i>Throttle Lever</i> . . . . .	31
<i>Shift Lever (HRB215SXA &amp; HRM215SXA)</i> . . .	31
<i>Blade Control Lever</i> . . . . .	32
<i>Drive Clutch Lever</i> <i>(HRB215SXA &amp; HRM215SXA)</i> . . . . .	32
<b>Stopping the Engine</b> _____	<b>33</b>
<b>Safe Mowing Practices</b> _____	<b>34</b>
<i>Slopes</i> . . . . .	34
<i>Obstacles</i> . . . . .	35
<i>Gravel and Loose Objects</i> . . . . .	35
<b>Mowing Tips</b> _____	<b>36</b>
<i>When to Mow</i> . . . . .	36
<i>Cutting Height</i> . . . . .	36
<i>Cutting Width</i> . . . . .	36
<i>Blade Speed</i> . . . . .	37
<i>Blade Sharpness</i> . . . . .	37
<i>Dry Grass</i> . . . . .	37
<i>Wet Grass</i> . . . . .	37
<i>Fallen Leaves</i> . . . . .	38
<i>If the Mower Deck Clogs</i> . . . . .	38
<i>Mowing Patterns</i> . . . . .	39

## Starting the Engine

Because of the risk of carbon monoxide poisoning, it makes good sense to start the mower outside, or at least in an open area with good ventilation.

Before starting, make sure the discharge guard is closed, or that the grass bag or side-discharge chute is in place.

### 1. FOR STARTING A COLD ENGINE:

Move the throttle lever to the **CHOKE** position.

### FOR RESTARTING A WARM ENGINE:

Move the throttle lever to the **FAST** position.

2. Place your foot on the mower deck step. Pull the starter grip lightly until you feel resistance, then pull briskly. Return the rope gently.

Always release the blade control lever before starting the engine to prevent the blade(s) from turning.

**HRB215SXA & HRM215SXA:**  
Always release the drive clutch lever before using the starter. If the drive clutch is engaged, the mower will move forward when you operate the starter.

Even though the blade does not turn until you pull back the blade control lever, it is good practice to keep hands and feet away from the mower deck at all times when the engine is running.

3. When the engine warms up, move the throttle lever away from the **CHOKE** position. Set the lever at **FAST** to mow or at **SLOW** to idle.

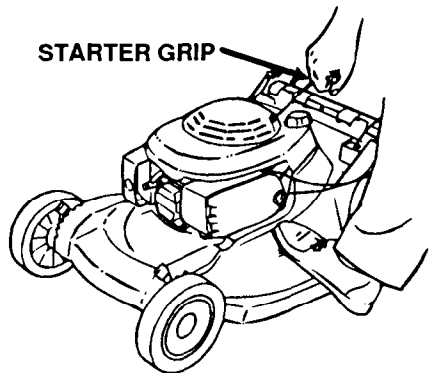
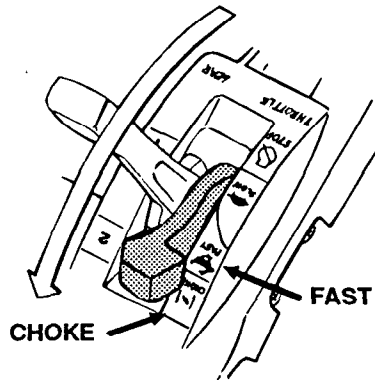

## Operating the Controls for Mowing

### Throttle Lever

Blade speed is as important as sharpness. When the blade rotates at high speed, it creates a strong fan action that lifts and cuts grass more efficiently. Always mow with the throttle lever in the FAST position, but do not try to increase the preset engine speed.

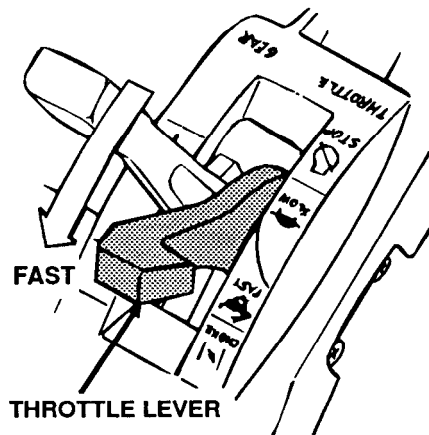

### Gear Shift Lever (HRB215SXA & HRM215SXA)

- 1 (slow) – For mowing thick grass or maneuvering in small areas.
- 2 (fast) – For maximum self-propelled speed in large, open areas.

To avoid incomplete gear engagement, move the shift lever all the way forward or all the way back.

You can shift gears without releasing the drive clutch lever (page 32), but the transmission may not shift smoothly if the mower is pulling hard. For smoother operation, release the drive clutch lever before shifting gears.

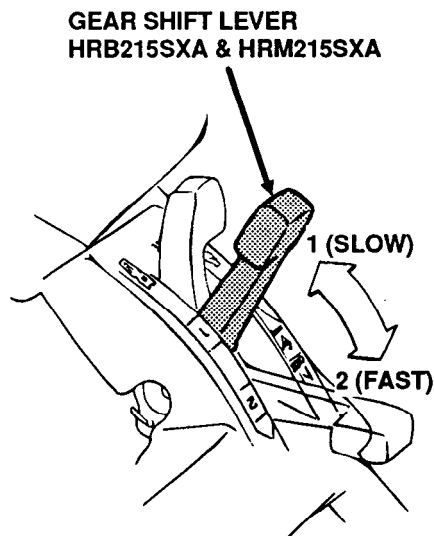

## MOWING

### Blade Control Lever

To start blade rotation, press the button on top of the blade control lever, then pull the lever back and hold it against the handlebar.

Release the blade control lever to stop the blade.

Operate the blade control lever with a quick and complete motion, so the blade drive is always either fully engaged or stopped. This will help to prevent stalling the engine, and it will also extend the service life of the blade control mechanism.

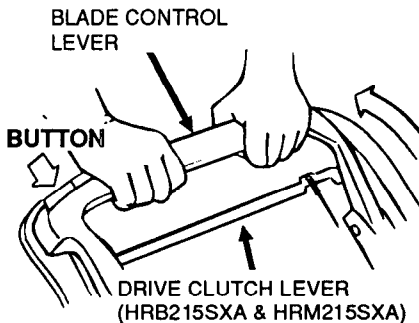

#### TO START BLADE ROTATION

DRIVE CLUTCH LEVER  
(HRB215SXA & HRM215SXA)

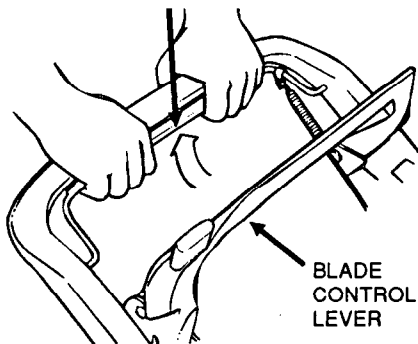

#### TO MOVE MOWER WITHOUT BLADE ROTATION

BLADE CONTROL LEVER

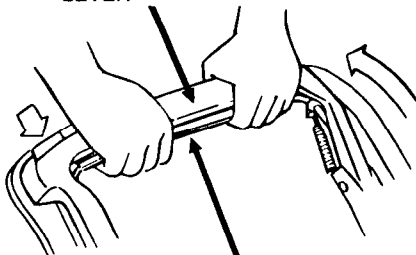

DRIVE CLUTCH LEVER  
(HRB215SXA & HRM215SXA)

#### FOR SELF-PROPELLED MOWING

### Drive Clutch Lever

(HRB215SXA & HRM215SXA)

To propel the mower, move the drive clutch lever up and hold it against the handlebar.

Release the drive clutch lever to stop the mower.

Operate the drive clutch lever with a quick and complete motion, so the drive clutch is always either fully engaged or released. This will help to extend the service life of the clutch mechanism.

For self-propelled mowing, press the button on top of the blade control lever, pull the blade control lever back, then move the drive clutch lever up against the handlebar. Hold both levers against the handlebar.

## Stopping the Engine

1. Release the drive clutch lever (HRB215SXA & HRM215SXA) and blade control lever (all models).
2. Move the throttle lever to the STOP position.

When the mower is not in use, leave the throttle lever in the STOP position to prevent carburetor flooding and to reduce the possibility of fuel leakage.

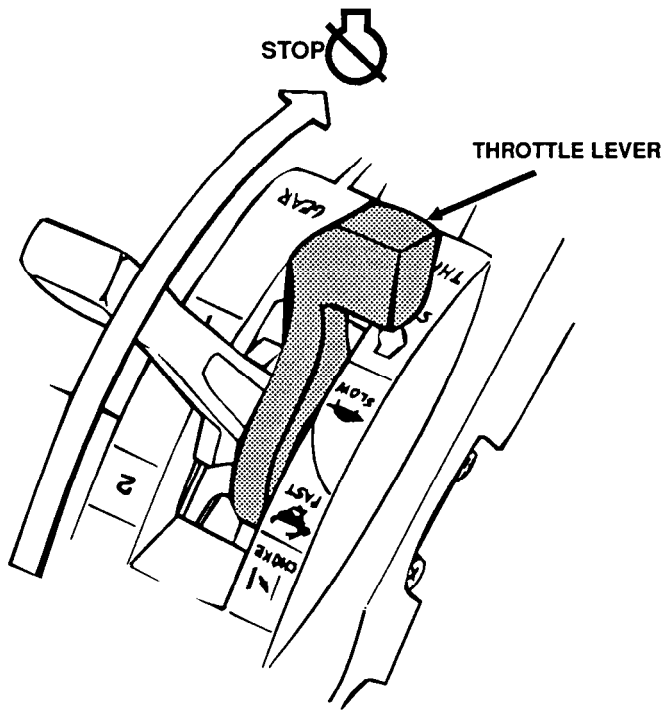

## MOWING

---

### Safe Mowing Practices

For your safety, keep all four wheels on the ground, and be careful to avoid losing your footing and your control of the mower. Keep a firm grip on the handlebar, and walk, never run, with the mower. Be very careful when mowing uneven or rough ground.

If stuck, do not kick or shove the mower with your foot. Use the handlebar to control the mower.

#### **⚠ WARNING**

The blade is sharp and spins at high speed.

A spinning blade can cut you severely and can amputate fingers and toes.

- Wear protective footwear.
- Keep your hands and feet away from the mower deck while the engine is running.
- Stop the engine before performing any adjustment, inspection, or maintenance.
- Never tilt the mower while the engine is running.
- Be careful to avoid losing your balance and slipping.

### Slopes

Mow across slopes, not up and down. Avoid steep slopes (more than 20°), and be careful when changing direction. Mowing on a slope when the grass is damp or wet could cause you to slip, fall, and lose control of the mower.

**MAXIMUM SLOPE: 20°**

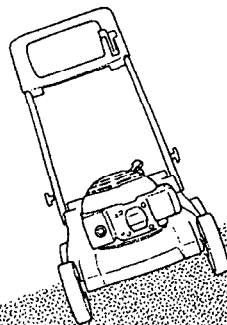

## Obstacles

Use the side of the mower to cut close to large obstacles, such as fences or walls.

Release the drive clutch lever to disengage the drive when mowing around trees and other obstacles. Push the mower around obstacles for better directional control. Be careful when mowing over obstacles embedded in the lawn, such as sprinkler heads, paving, edging, etc. Avoid anything that sticks up above the surface of the lawn.

If the blade(s) hit something, or if the mower starts to vibrate, stop the engine immediately and check for damage. Striking objects may damage the blade(s), bend the crankshaft, and/or break the mower deck or other components. Vibration usually indicates serious trouble.

### **WARNING**

Worn, cracked, or damaged blades can break, and pieces of damaged blades can become dangerous projectiles.

Thrown objects can cause serious injury.

Inspect the blades regularly, and do not operate the mower with worn or damaged blades.

The Distributor's Limited Warranty does not cover parts damaged by accident or collision.

## Gravel and Loose Objects

The best way to prevent potential injury from thrown objects is to release the blade control lever to stop the blade(s) before reaching areas with gravel, loose stones, or landscaping material.



### Mowing Tips

#### When to Mow

Most grasses should be mowed when they have grown 1/2 to 1 inch above their recommended height.

For best mulching results, mow the lawn frequently, cutting off less than one inch of grass each time. In growing season, you will probably need to mow the lawn twice a week.



#### Cutting Height

Consult a local nursery or lawn and garden center for cutting height recommendations and advice about specific types of grasses and growing conditions in your area.

If you look closely, you'll see that most grass has stems and leaves. If you cut off the leaves, you'll scalp the lawn. Let the grass recover between mowings. Your mower will work better, and your lawn will look better.



**LONG  
ENOUGH**



**TOO SHORT**

If your grass gets too tall, cut it once at the highest cutting height setting, then mow again in 2 or 3 days. Don't take off more than one third of total grass height in any one mowing, or brown patches may develop.

Cutting height adjustment is explained on page 18.

## Cutting Width

For an even lawn finish, overlap each mowing swath by a few inches. If the grass is very tall or thick, use more overlap and a narrower mowing swath.

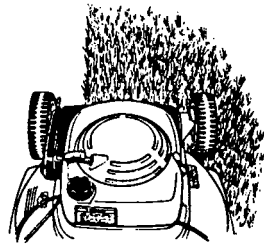

## Blade Speed

The blade must spin very fast to cut properly. Always use the FAST throttle setting, and keep the engine running at maximum rpm.

If engine speed drops, that means the blade is trying to cut too much grass. Mow a narrower swath, move the mower more slowly, or raise the cutting height.

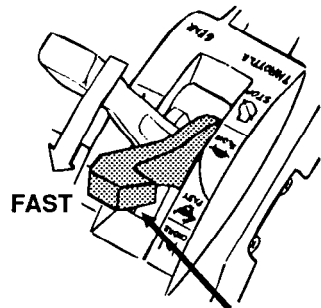

**TROTTLER LEVER**

## Blade Sharpness

Sharp blades cut cleanly. Dull blades tear the grass, leaving shredded ends that turn brown.

When your blade(s) doesn't cut cleanly anymore, have it sharpened or replaced (see page 58).

## Dry Grass

If the ground is too dry, mowing will stir up a lot of dust. Besides being unpleasant to work in, too much dust will clog the carburetor air filter.

If dust is a problem, water your lawn the day before mowing. Mow when the grass is dry to your touch, but the soil is still moist.

## Wet Grass

Wet grass is slippery and can make you lose your footing. Also, wet grass clippings will clog the mower deck and collect in clumps on the lawn. Always wait for wet grass to dry before mowing.

### Fallen Leaves

If you want to mulch fallen leaves into your lawn, don't let the leaf cover get too deep before you begin. For best results, start mulching while grass still shows through the leaf cover.

Mulching blades (see page 8) and the mulching plug (see page 9) are standard equipment on HRM215 mowers. They can be installed as optional equipment on HRB215 mowers.

In places where fallen leaves completely cover the grass, remove the leaves by raking, or install the grass bag, so your mower can pick them up for disposal.

The grass bag is standard equipment on HRB215 mowers (see page 9) and can be installed as optional equipment on HRM215 mowers.

If using your mower to bag large accumulations of fallen leaves for disposal, and not for mowing or mulching, set the cutting height adjustment levers so the front of the mower deck is one or two settings higher than the rear.



### If the Mower Deck Clogs

Before clearing a clogged mower deck, stop the engine, leave the throttle lever in the STOP position and disconnect the spark plug cap. Tilt the mower so the carburetor side is up.

Clear a clogged deck with a stick, not your hands.

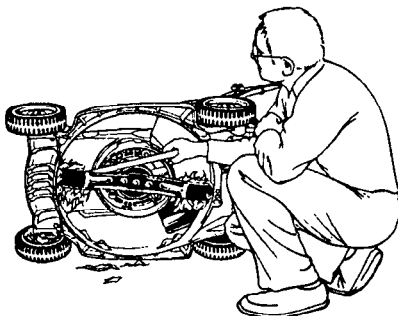

## Mowing Patterns

Your Honda mower will work most efficiently if you use the following mowing patterns as much as possible. Mower deck and equipment design, and the direction in which the blade(s) rotates, cause these mowing patterns to give the best results.

### MULCHING

Mulching requires the mulching blades (see page 8) and mulching plug (see page 9) that are standard equipment on HRM215 mowers and optional for HRB215 mowers.

Use a counterclockwise mowing pattern. If the lawn has an irregular shape, or many obstacles, divide it into sections where you can use counterclockwise mowing patterns.

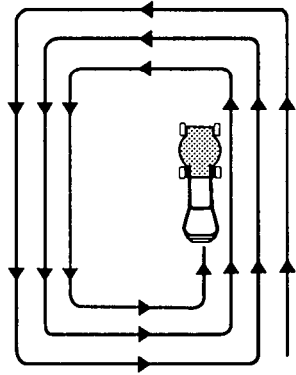

**MULCHING PATTERN**

### BAGGING

Bagging requires the grass bag (see page 9) that is standard equipment on HRB215 and optional for HRM215 mowers.

Use a clockwise mowing pattern. This will give the best bagging performance, leaving the least amount of clippings on the lawn.

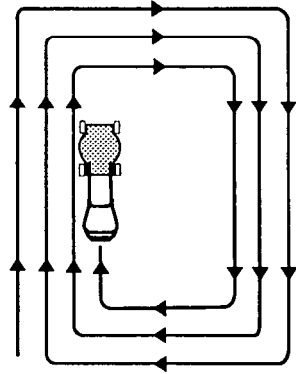

**BAGGING & SIDE-DISCHARGE PATTERN**

### SIDE-DISCHARGE MOWING

The side-discharge chute (see page 10) is optional equipment for HRB215 and HRM215 mowers.

Use a clockwise mowing pattern, starting at the outer edges of the lawn and working toward the center. This will prevent clippings from piling up in the path of the mower.



# TRANSPORTING THE MOWER

*This section explains how to load and carry your mower safely.*

Before Loading \_\_\_\_\_ 42

Loading and unloading \_\_\_\_\_ 42

## TRANSPORTING THE MOWER

---

### Before Loading

If the engine has been running, allow it to cool for at least 15 minutes before loading the mower on the transport vehicle.

Remove the grass bag, if so equipped.

Be sure the throttle lever is in the STOP position to prevent carburetor flooding and reduce the possibility of fuel leakage.

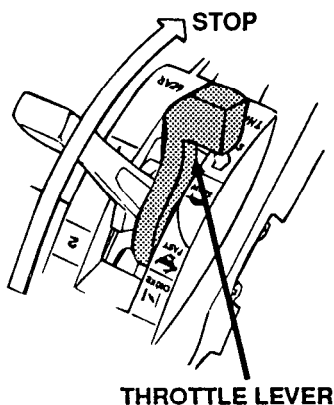

### Loading and Unloading

If a suitable loading ramp is not available, two people should lift the mower on and off the transport vehicle while holding the mower level.

Position the mower so all four wheels are on the bed of the transport vehicle. Tie the mower down with rope or straps, and block the wheels. Keep the tie-down rope or straps away from the controls, adjustment levers, cables, and the carburetor.

The handlebar can be folded so the mower will take up less space (see page 17).

If unloading a self-propelled mower backward, down a loading ramp, avoid touching the drive clutch lever. Engaging the drive clutch, while rolling backward down a ramp, can damage the drive system.

# MAINTENANCE & ADJUSTMENTS

*This section explains when and how to perform routine inspection, service, and adjustments for do-it-yourself maintenance.*

*More difficult maintenance tasks should be done by your dealer. Your dealer is best equipped and staffed to provide the level of service and safety you and your mower deserve.*

<b>Maintenance Precautions</b> _____	<b>44</b>
<b>Maintenance Schedule</b> _____	<b>45</b>
<b>Engine Maintenance</b> _____	<b>46</b>
<i>Engine Oil Change</i> . . . . .	46
<i>Air Cleaner Service</i> . . . . .	48
<i>Spark Plug Service</i> . . . . .	49
<i>Spark Arrester Service (optional equipment)</i> .	51
<i>Carburetor Adjustment</i> . . . . .	52
<i>Carburetor Modification for High Altitude</i> . . . .	53
<b>Cable Adjustments</b>	
<i>Blade Control Cable Adjustment</i> . . . . .	54
<i>Drive Clutch Cable Adjustment</i> <i>(HRB215SXA &amp; HRM215SXA)</i> . . . . .	55
<i>Throttle Cable Adjustment</i> . . . . .	56
<i>Gear Shift Cable Adjustment</i> <i>(HRB215SXA &amp; HRM215SXA)</i> . . . . .	57
<b>Blade Removal and Installation</b>	
<i>Blade Removal</i> . . . . .	58
<i>Blade Installation</i> . . . . .	59
<b>Grass Bag Cleaning and Replacement</b> _____	<b>60</b>
<i>Grass Bag Cleaning</i> . . . . .	60
<i>Grass Bag Replacement</i> . . . . .	60



### Maintenance Precautions

Periodic maintenance and adjustments are necessary to keep your mower in good operating condition. Service and inspect according to the MAINTENANCE SCHEDULE (page 45).

#### **WARNING**

If you do not follow these safety precautions, you can be seriously hurt or killed.

Carefully read and follow all safety instructions.

The engine and exhaust system become hot enough to burn you and may cause a fire if flammable materials are nearby. Allow the engine to cool for at least 15 minutes before maintenance or indoor storage.

Gasoline is highly flammable and explosive. Refuel outdoors with the engine stopped. Wipe up spills immediately. Never use gasoline to clean parts.

To prevent carbon monoxide poisoning, stop the engine before making any inspection or repair. If you must run the engine, do it outdoors or provide adequate ventilation. If you start feeling drowsy, stop the engine immediately and get fresh air.

Use genuine Honda parts or their exact equivalent for maintenance and repair. Lower quality parts may damage the mower or reduce its performance.

Keep all nuts, bolts, and screws tight to be sure the equipment is in safe working order.

Wear heavy gloves to protect your hands when working on the mower, especially when you work on or near the blade(s).

## Maintenance Schedule

<b>Regular Service Interval</b>		Before Each Use	First 20 Hours	Every 50 Hours	Every 100 Hours	Every 300 Hours
<b>Item</b>	Perform at every indicated interval					
Blade condition and blade bolt tightness	Check	●				
Grass bag (if equipped)	Check	●				
Engine oil	Check	●				
	Change		●		●	
Air cleaner	Check	●				
	Clean			● <sup>1</sup>		
Spark plug	Check & clean				●	
Spark arrester (optional equipment)	Check				●	
Blade control mechanism	Check		● <sup>2</sup>		● <sup>2</sup>	
Blade control cable	Adjust		●		●	
Drive clutch cable (HRB215SXA & HRM215SXA only)	Adjust		●		●	
Throttle cable	Adjust		● <sup>2</sup>		● <sup>2</sup>	
Shift cable (HRB215SXA & HRM215SXA only)	Adjust		●		●	
Valve Clearance	Adjust					● <sup>2</sup>
Fuel tank	Clean					● <sup>2</sup>
Fuel line	Replace		Every 2 years <sup>2</sup>			

<sup>1</sup> Service more frequently when used in dusty areas.

<sup>2</sup> These items should be serviced by an authorized Honda lawn mower dealer, unless you have the proper tools and are mechanically proficient. Refer to the Honda shop manual.

## Engine Maintenance

### Engine Oil Change

Drain the used oil while the engine is warm. Warm oil drains quickly and completely.

1. Place a suitable container next to the mower to catch the used oil.
2. Wipe the oil filler area clean, then remove the oil filler cap/dipstick.
3. With the throttle lever in the STOP position to reduce the possibility of fuel leakage, tilt the mower on its right side. The used oil will drain through the filler neck. Allow the oil to drain completely.

Please dispose of used engine oil in a manner that doesn't harm the environment. Do not throw it in the trash or pour it on the ground or down the drain.

4. Fill with the recommended oil. Do not overfill; measure the oil level as shown on page 47.

**Engine oil capacity: 0.6 l (0.63 US qt).**

Use high-detergent, premium quality 4-stroke engine oil, certified to meet or exceed U.S. automobile manufacturers' requirements for API Service Classification SG, SF/CC, CD.

#### NOTICE

Using nondetergent oil can shorten the engine's service life, and using 2-stroke oil can damage the engine.

SAE 10W-30 is recommended for general, all-temperature use. Other viscosities shown in the chart may be used when the average temperature in your area is within the indicated range.

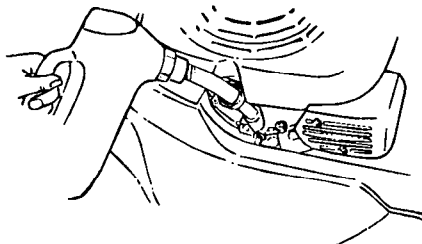
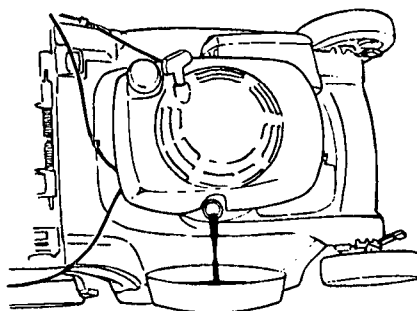
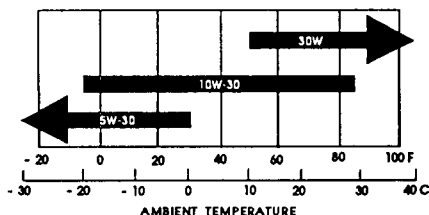

## MAINTENANCE & ADJUSTMENTS

5. After changing the engine oil, and before starting the engine, check the oil level with the mower on a level surface:
  - a. Wipe the dipstick clean.
  - b. Insert and remove the dipstick without screwing it into the filler neck. Check the oil level shown on the dipstick.
  - c. If the oil level is low, add oil to reach the upper limit mark on the dipstick. Do not overfill.

### NOTICE

Running the engine with a low oil level can cause engine damage.

- d. Screw in the filler cap/dipstick securely.

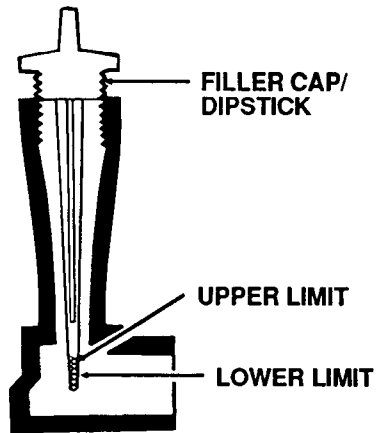
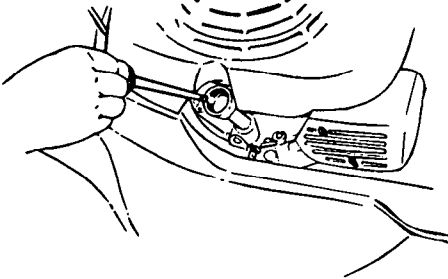

### Air Cleaner Service

Dirty air filters will restrict air flow to the carburetor, reducing engine performance. If you operate the mower in very dusty areas, clean the air filters more often than specified in the MAINTENANCE SCHEDULE.

#### NOTICE

Operating the engine without air filters, or damaged filters, will allow dirt to enter the engine, causing rapid engine wear. This type of damage is not covered by the Distributor's Limited Warranty.

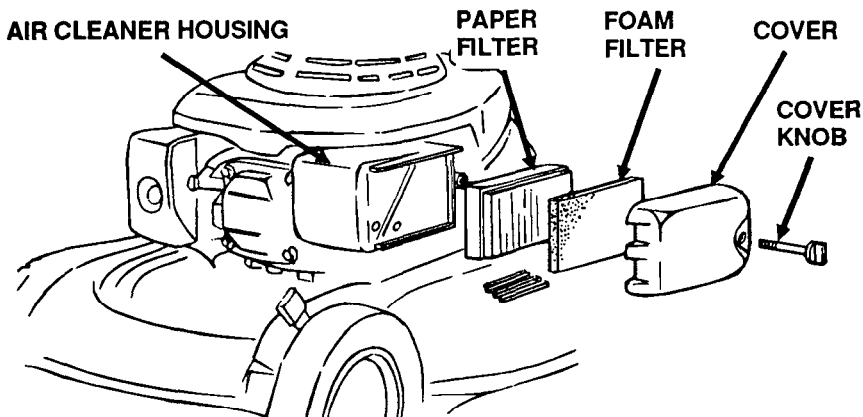

1. Unscrew and remove the air cleaner cover knob, then remove the air cleaner cover.
2. Remove the paper filter from the air cleaner housing. Remove the foam filter from the cover.
3. Inspect the filters, and replace them if they are damaged.
4. Clean the filters.

**Paper filter:** Tap the filter several times on a hard surface to remove dirt, or blow compressed air [not exceeding 207 kPa (30 psi)] through the filter from the inside. Never try to brush off dirt; brushing will force dirt into the fibers.

**Foam filter:** Clean in warm soapy water, rinse, and allow to dry thoroughly. Or clean in nonflammable solvent and allow to dry. Dip the filter in clean engine oil and squeeze out all excess oil.

## NOTICE

Excess oil will restrict air flow through the foam filter and may transfer to the paper filter, soaking and clogging it.

5. Wipe dirt from the inside of the air cleaner housing and cover, using a moist rag. Be careful to prevent dirt from entering the air duct that leads to the carburetor.
6. Reinstall the filters and cover. Tighten the cover knob securely.

## Spark Plug Service

RECOMMENDED SPARK PLUGS	REGULAR	RESISTOR *
NGK	BP5ES	BPR5ES
ND	W16EP-U	W16EPR-U
CHAMPION	N12Y	RN12Y

\* Resistor spark plugs reduce interference with radio and TV reception.

## NOTICE

An incorrect spark plug can cause engine damage.

For good performance, the spark plug must be properly gapped and free of deposits.

1. Disconnect the spark plug cap, and remove any dirt from around the spark plug area.
2. Remove the spark plug with a 20.6 mm (13/16 in) spark plug wrench.
3. Inspect the spark plug. Replace it if the electrodes are worn, or if the insulator is cracked or chipped. Clean the spark plug with a wire brush if you are going to reuse it.

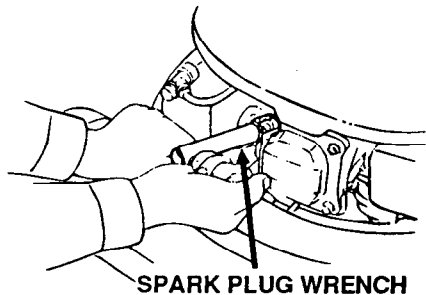
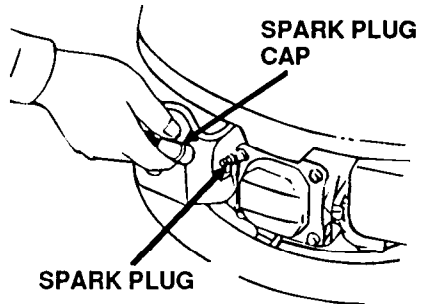

## MAINTENANCE & ADJUSTMENTS

---

4. Measure the spark plug electrode gap with a feeler gauge. The gap should be 0.7 – 0.8 mm (0.028 – 0.031 in). Correct the gap, if necessary, by carefully bending the side electrode.
5. Install the spark plug carefully, by hand, to avoid cross-threading.
6. After the spark plug seats, tighten with a 20.6 mm (13/16 in) spark plug wrench to compress the washer.

If reinstalling the old spark plug, tighten 1/8 to 1/4 turn after the spark plug seats.

If installing a new spark plug, tighten 1/2 turn after the spark plug seats to compress the washer.

### NOTICE

A loose spark plug can overheat and damage the engine. Overtightening the spark plug can damage the threads in the cylinder head.

7. Install the spark plug cap on the spark plug.

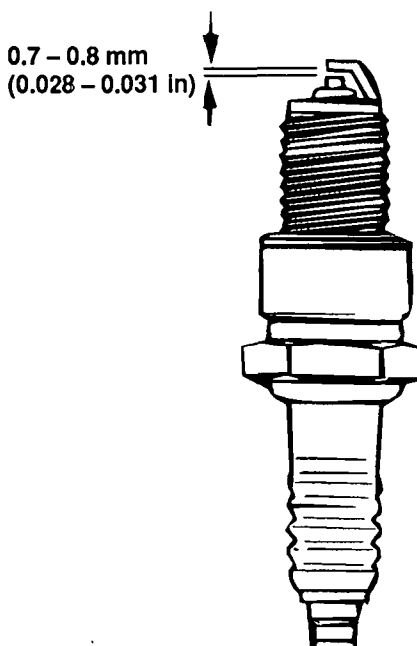

### Spark Arrester Service (optional equipment)

In some areas, it is illegal to operate an engine without a spark arrester. Check local laws and regulations. A spark arrester is available from authorized Honda lawn mower dealers.

The spark arrester must be serviced every 100 hours to keep it functioning as designed.

1. Remove the two nuts from the muffler shield, using a 10 mm wrench.
2. Remove the muffler shield, identification plate, muffler, and gasket.
3. Remove the spark arrester from the muffler.
4. Check for carbon deposits on the spark arrester and the exhaust port. Brush carbon deposits away. Be careful to avoid damaging the spark arrester screen.
5. Install the spark arrester in the muffler.
6. Install the muffler components on the engine, and tighten the two nuts securely.

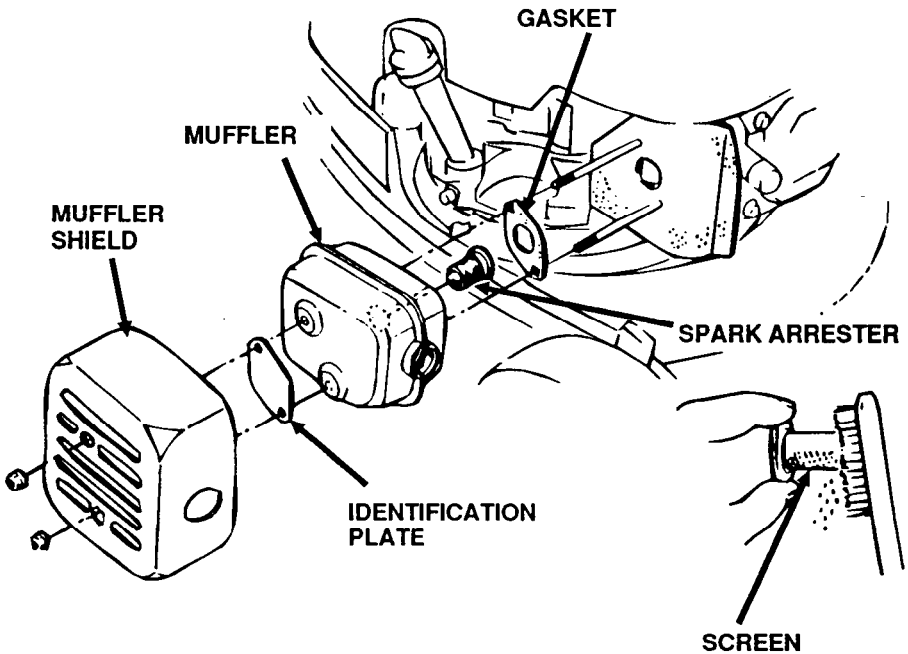



## **MAINTENANCE & ADJUSTMENTS**

---

### **Carburetor Adjustment**

1. Start the engine outdoors, and allow it to warm up to normal operating temperature.
2. Set the throttle lever in the SLOW position.
3. Turn the pilot screw in or out to the setting that produces the highest idle rpm. The correct setting will usually be approximately 2 turns out from the fully closed position.
4. After the pilot screw is correctly adjusted, turn the throttle stop screw to obtain the standard idle speed.

**Standard idle speed:**  
**2,000 ± 150 rpm**

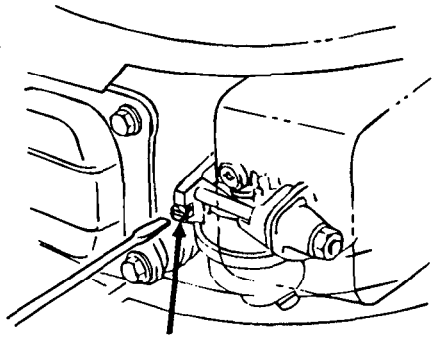

**PILOT SCREW**

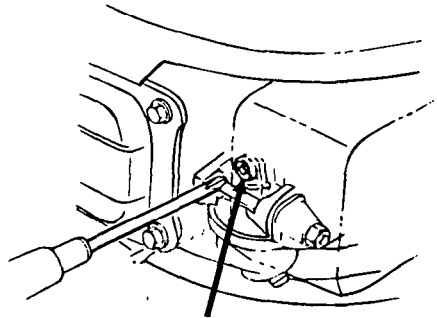

**THROTTLE STOP SCREW**

## Carburetor Modification for High Altitude Operation

At high altitude, the standard carburetor air-fuel mixture will be too rich. Performance will decrease, and fuel consumption will increase. A very rich mixture will also foul the spark plug and cause hard starting.

High altitude performance can be improved by installing a smaller diameter main fuel jet in the carburetor and readjusting the pilot screw. If you always operate the mower at altitudes higher than 1,800 meters (6,000 feet) above sea level, have an authorized Honda lawn mower dealer perform this carburetor modification.

Even with carburetor modification, engine horsepower will decrease about 3.5% for each 300 meter (1,000 foot ) increase in altitude. The effect of altitude on horsepower will be greater than this if no carburetor modification is made. A reduction in engine horsepower will reduce mowing performance.

### **NOTICE**

When the carburetor is modified for high altitude operation, the air-fuel mixture will be too lean for low altitude use. Operation at altitudes below 1,800 meters (6,000 feet), with high altitude carburetor modifications, may cause the engine to overheat and result in serious engine damage. For low altitude use, reinstall the standard main fuel jet, and readjust the pilot screw.

### Control Cable Adjustments.

#### Blade Control Cable Adjustment

Measure free play at the top of the lever, while holding the button down. Free play should be 20 – 25 mm (3/4 – 1 in). If adjustment is necessary:

1. Loosen the locknuts with a 10 mm wrench, and move the adjuster up or down as required.
2. Tighten the locknuts and recheck free play.
3. Start the engine outdoors, and operate the blade control lever. Check that the blade starts when you pull back the lever and stops quickly when you release the lever.

If the blade does not start or stop as it should, with correct cable adjustment, repair may be needed. Take the mower to an authorized Honda lawn mower dealer.

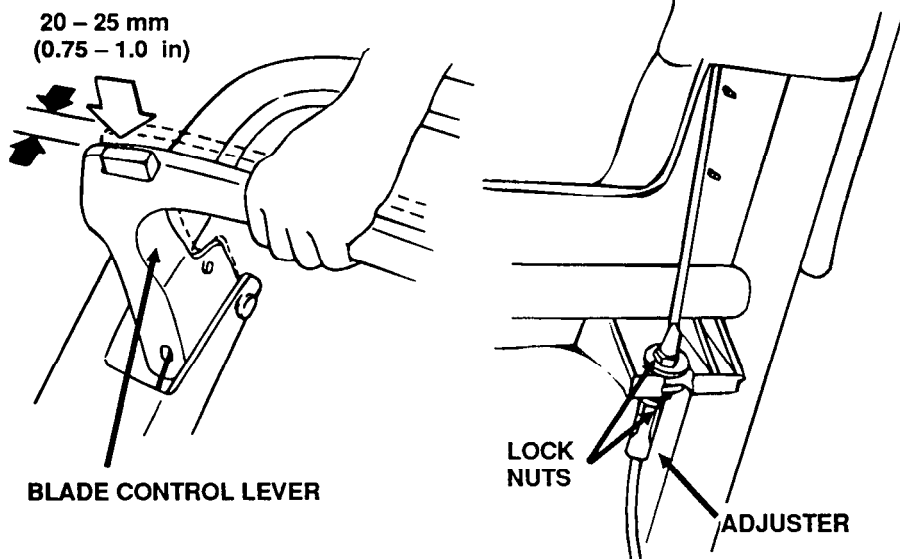

### Drive Clutch Cable Adjustment (HRB215SXA & HRM215SXA)

Measure free play at the edge of the lever, as shown. Free play should be 1 – 4 mm (1/16 – 3/16 in). If adjustment is necessary:

1. Loosen the locknuts with a 10 mm wrench and move the adjuster up or down as required.
2. Tighten the locknuts and recheck free play.
3. Start the engine outdoors, and operate the drive clutch lever. Check to be sure the drive clutch engages and releases properly.

If the drive clutch does not operate properly, with correct cable adjustment, repair may be needed. Take the mower to an authorized Honda lawn mower dealer.

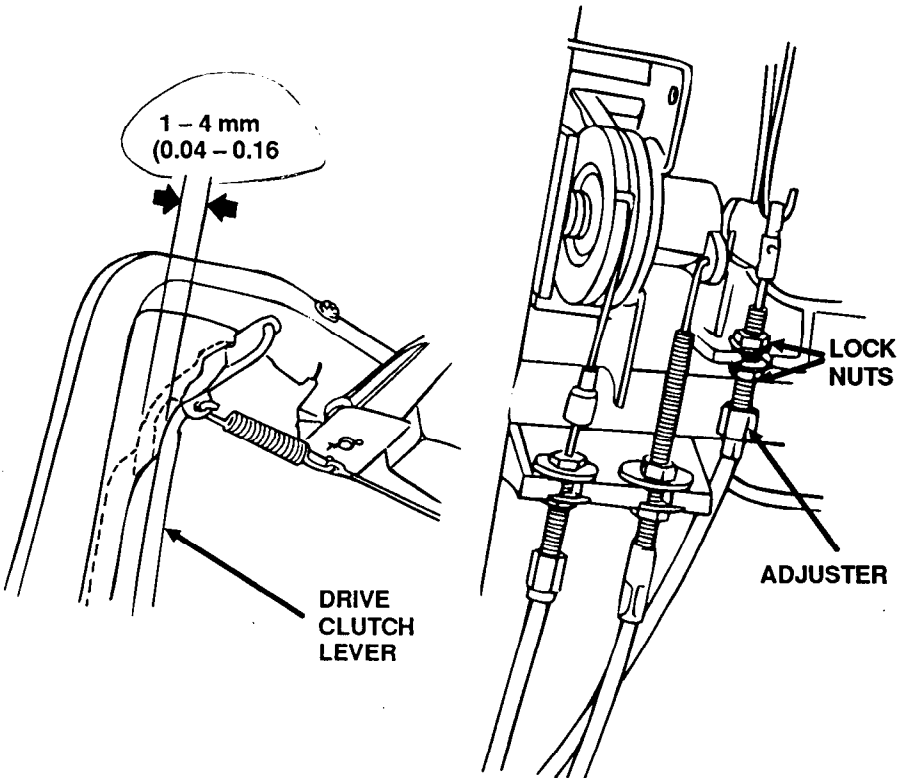

## MAINTENANCE & ADJUSTMENTS

### Throttle Cable Adjustment (HRB215SXA & HRM215SXA)

Throttle cable adjustment is necessary if the throttle lever does not operate the choke properly.

You can inspect choke operation by observing the movement of the choke arm, which is located on top of the carburetor.

1. Move the throttle lever to the CHOKE position. The choke arm should move counterclockwise, until it contacts the stop post on the carburetor.

Push the choke arm with your finger to verify that it has moved as far as it will go.

2. Move the throttle lever to the FAST position. The choke arm should move clockwise, until it contacts the stop post on the carburetor.

Push the choke arm with your finger to verify that it has moved as far as it will go.

3. If the choke arm does not move all the way to its stop, in either direction, take the mower to an authorized Honda lawn mower dealer. Throttle cable adjustment involves related control plate adjustments.

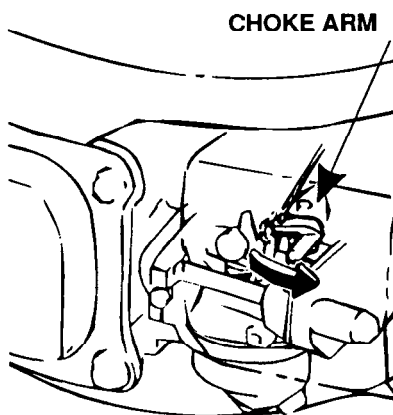
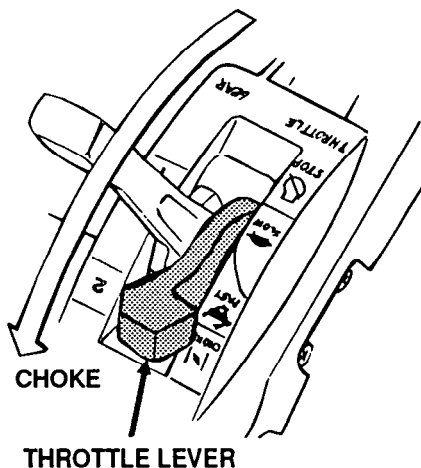

### Gear Shift Cable Adjustment (HRB215SXA & HRM215SXA only)

With the transmission in 1st gear, pull the gear shift lever all the way back and release it; the lever should be centered on the number "1" on the lever cover. If adjustment is necessary:

1. Loosen the locknuts with a 10 mm wrench and move the adjuster up or down as required.
2. Tighten the locknuts and recheck lever alignment.
3. Verify that the lever operates smoothly.
4. Start the engine and verify that the shift lever engages 1st and 2nd gear by engaging the drive clutch lever. Readjust if necessary.

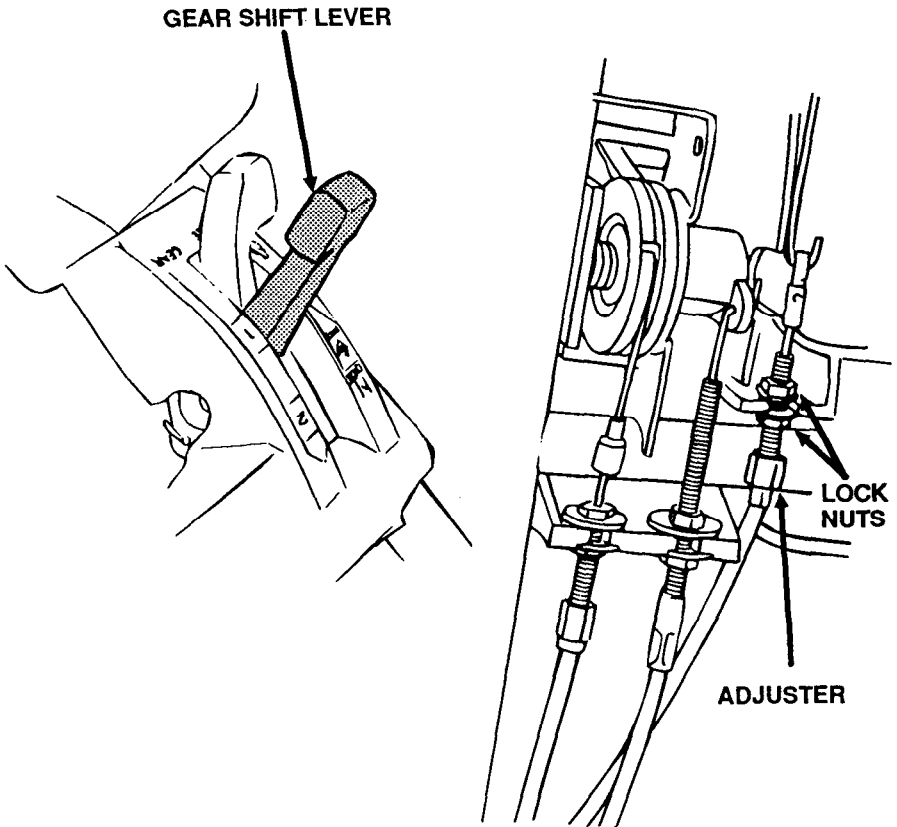

### **Blade Removal and Installation**

If you remove the blade(s) for sharpening or replacement, you will need a torque wrench for installation. Wear heavy gloves to protect your hands.

**BLADE SHARPENING:** To avoid weakening the blade(s), or causing imbalance or poor cutting, the blade(s) should be sharpened by trained staff at an authorized Honda lawn mower dealer.

**BLADE REPLACEMENT:** Use genuine Honda replacement blades or their equivalent.

#### **Blade Removal**

1. With the throttle lever in the STOP position and the spark plug cap disconnected, tilt the mower to the right side, so the carburetor side is up. This will help to prevent fuel leakage and hard starting due to carburetor flooding.
2. Remove the two blade bolts with a 14 mm socket wrench. Use a wooden block to prevent the blade(s) from turning when removing the bolts.
3. Remove the blade(s) from the blade control assembly.

**UPPER MULCHING BLADE**  
(standard for HRM215)  
(not used with high-lift blade)

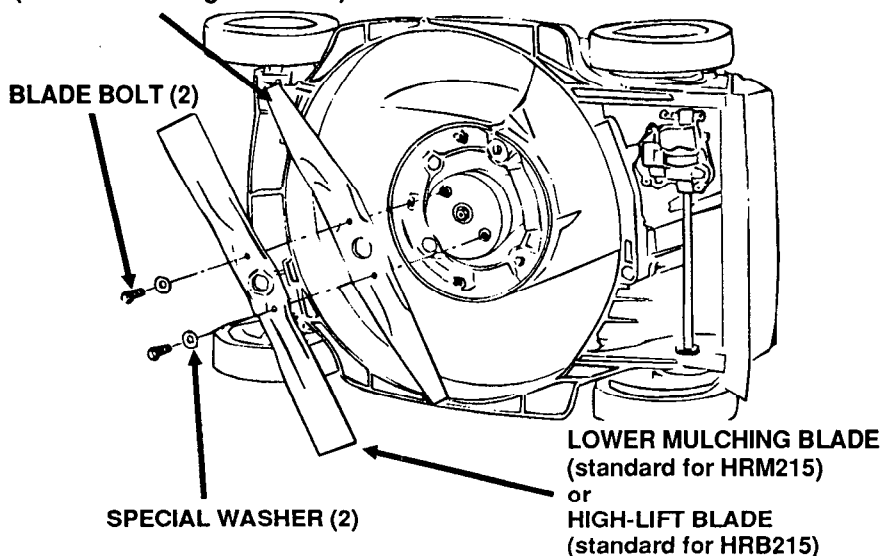

### Blade Installation

1. Clean dirt and grass from around the blade mounting area.
2. Install the blade(s) using the two blade bolts and special washers as shown.

Be sure to install the special washers with the concave side toward the blade(s) and the convex side toward the bolts.

The blade bolts are specially designed for this application and must not be replaced with other bolts.

3. Tighten the blade bolts with a torque wrench. Use a wooden block to prevent the blade(s) from turning when tightening the bolts.

**Blade bolt torque: 49 - 59 N·m (5.0 - 6.0 kg·m, 36 - 43 ft·lb)**

If you do not have a torque wrench, have an authorized Honda lawn mower dealer tighten the blade bolts before you use the mower. If the blade bolts are overtightened, they could break. If the blade bolts are not tightened enough, they could loosen or come out. In either case, it would be possible for the blade(s) to fly off while you are operating the mower.

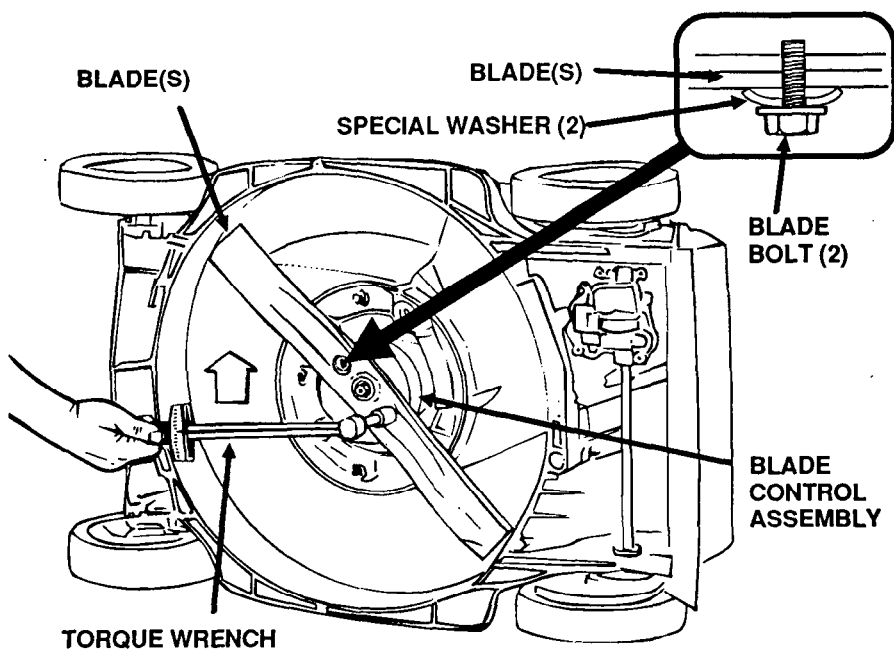



## MAINTENANCE & ADJUSTMENTS

### Grass Bag Cleaning and Replacement

(standard equipment for HRB215, optional for HRM215)

#### Grass Bag Cleaning

Wash the bag with a garden hose, and allow it to dry completely before use; a wet bag will clog quickly.



#### Grass Bag Replacement

Replace a worn or damaged bag with a Honda replacement bag or its equivalent.

#### ⚠ WARNING

Objects hit by the blade(s) can be thrown through a worn or damaged grass bag.

Thrown objects can seriously injure you.

Replace the grass bag if it is worn or damaged.

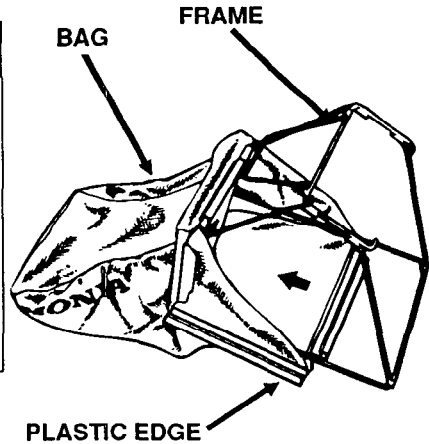

1. Unclip the plastic edges of the used bag, and remove it from the bag frame.
2. Insert the bag frame in the new bag, and clip the plastic edges onto the bag frame.

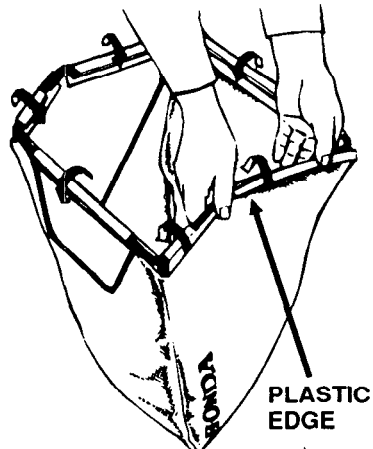

# TROUBLESHOOTING

*This section shows what to check if you have a problem with your mower.*

<b>Engine Problems</b> _____	<b>62</b>
<i>Engine will not start</i> . . . . .	62
<i>Loss of power</i> . . . . .	62
<b>Vibration Problems</b> _____	<b>63</b>
<b>Mowing/Mulching/Bagging Problems</b> _____	<b>63</b>

# TROUBLESHOOTING

## Engine Problems

ENGINE WILL NOT START	POSSIBLE CAUSE	CORRECTION
1. Check throttle lever position.	Throttle lever in wrong position.	Move throttle lever to CHOKE position unless engine is warm (p.30).
2. Check fuel.	Out of fuel.  Bad fuel; mower stored without treating or draining gasoline, or refueled with bad gasoline.	Refuel (p. 23).  Drain fuel tank and carburetor (p.69). Refuel with fresh gasoline (p. 23).
3. Remove and inspect spark plug.	Spark plug faulty, fouled, or improperly gapped.  Spark plug wet with fuel (flooded engine).	Clean, gap, or replace spark plug (p. 49).  Dry and reinstall spark plug. Start engine with throttle lever in FAST position.
4. Take mower to Honda lawn mower dealer, or refer to shop manual.	Fuel filter clogged, carburetor malfunction, ignition malfunction, valves stuck, etc.	Take mower to Honda lawn mower dealer, or refer to shop manual.

LOSS OF POWER	POSSIBLE CAUSE	CORRECTION
1. Check under mower deck.	Mower deck clogged.	Clean out mower deck (p. 38).
2. Check air filters.	Air filters clogged.	Clean or replace air filters (p. 48).
3. Check fuel.	Bad fuel; mower stored without treating or draining gasoline, or refueled with bad gasoline.	Drain fuel tank and carburetor (p. 69). Refuel with fresh gasoline (p. 23).
4. Check vent inside fuel tank cap.	Fuel tank cap vent clogged.	Clean fuel tank cap vent.
5. Take mower to Honda lawn mower dealer, or refer to shop manual.	Fuel filter clogged, carburetor malfunction, ignition malfunction, valves stuck, etc.	Take mower to Honda lawn mower dealer, or refer to shop manual.

**Vibration Problems**

<b>EXCESSIVE VIBRATION</b>	<b>POSSIBLE CAUSE</b>	<b>CORRECTION</b>
1. Check mower deck and blade(s).	Grass and debris lodged under mower deck.  Blade(s) loose, bent, damaged, or unbalanced by improper sharpening.	Tighten loose blade bolts. Replace damaged blade(s) (p. 58 - 59).
2. Take mower to Honda lawn mower dealer for repair.	Mechanical damage, such as a bent crankshaft.	Take mower to Honda lawn mower dealer, or refer to shop manual.

**Mowing/Mulching/Bagging Problems**

<b>POOR CUT QUALITY OR POOR MOWING/MULCHING/BAGGING PERFORMANCE</b>	<b>POSSIBLE CAUSE</b>	<b>CORRECTION</b>
1. Check that the throttle lever is in the FAST position.	Engine speed is too slow to cut well.	Move throttle lever to the FAST position (p. 27).
2. Reduce forward speed.	Mower is moving too fast for lawn conditions.	Shift to slow speed (HRB215SXA & HRM215SXA: (p. 31), or push slower.
3. Check cutting height adjustment levers.	Adjustment levers set at different positions.	Set all levers at the same cutting height position (p. 11).
4. Check grass bag (if equipped)	Grass bag overfilled or clogged.	Empty the grass bag. Wash the grass bag if clogged with dirt (p. 60).
5. Check cutting height.	Cutting height set to low for grass height.	Raise the cutting height or use more overlap (p. 36 - 37).



# STORAGE

*This section explains how to protect your mower from rust and corrosion, and ensure that it will start easily when you want to use it again.*

Basic Preparation for Storage _____	66
Preparation for Storage of 1 or 2 months _____	67
Preparation for Storage longer than 2 months _____	68
Storage _____	70
Removal from Storage _____	71

## STORAGE

---

### Storage Preparation

Proper storage preparation is essential for keeping your lawn mower trouble free and looking good. The following steps will help to keep rust and corrosion from impairing your mower's function and appearance, and will make the engine easier to start when you use the mower again.

### Cleaning

Clean all surfaces of the mower, including the underside of the mower deck. Wear heavy gloves to protect your hands from the blade.

Before cleaning the underside of the mower deck, be sure the throttle lever is in the STOP position to shut OFF the fuel valve. Rest the mower on its right side, so the carburetor side is up. This will help to prevent fuel leakage and hard starting due to carburetor flooding.

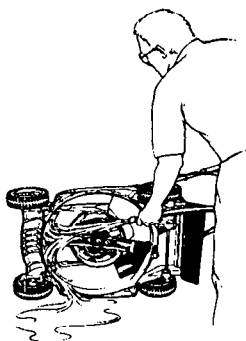

1. Wash the mower with a garden hose or other low pressure equipment.
2. If the mower has been running, allow the engine to cool for at least half an hour before spraying water on it. Never spray water on a hot engine. Cooling the engine too quickly can cause damage.
3. Try to keep water away from controls, cable ends, wheel hubs, transmission and all other places that are difficult to dry if water enters as water may promote rust.
4. After washing, set the mower in an upright position again, remove as much standing water as possible with a dry cloth, start the engine outdoors, and let it run until it reaches normal operating temperature to evaporate any water remaining on the engine.
5. With the engine running, operate the blade control lever 4 or 5 times to expel water from the blade control mechanism. Allow the blade to spin for several minutes to ensure that no water remains.
6. Stop the engine, and allow it to cool.

7. Wash the grass bag (if equipped) with a garden hose and allow it to dry completely.



8. After the mower is clean and dry, touch up any damaged paint, and coat other areas that may rust with a light film of oil. Lubricate all control cable cores with a silicone spray lubricant.

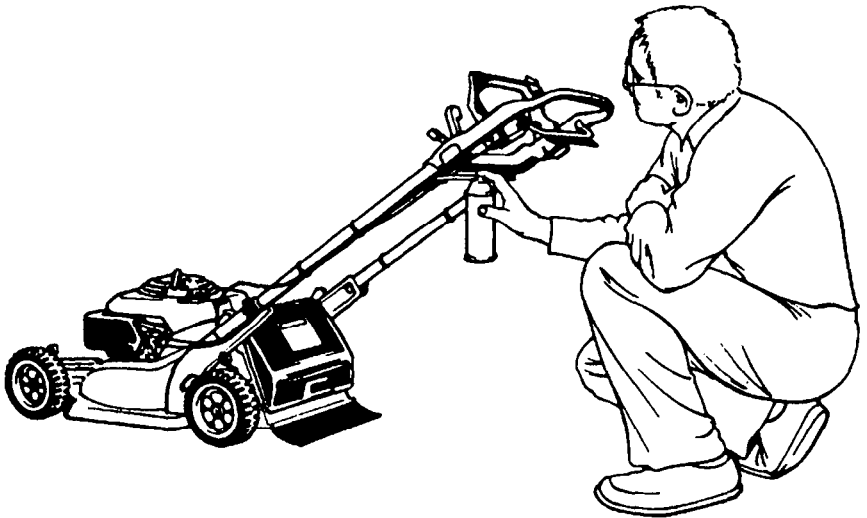



## STORAGE

---

### FUEL

Gasoline will oxidize and deteriorate in storage. Old gasoline will cause hard starting, and it leaves gum deposits that clog the fuel system. If the gasoline in your mower deteriorates during storage, you may need to have the carburetor and other fuel system components, serviced or replaced.

The length of time that gasoline can be left in your fuel tank and carburetor without causing functional problems will vary with such factors as gasoline blend, your storage temperatures, and whether the fuel tank is partially or completely filled. The air in a partially filled fuel tank promotes fuel deterioration. Very warm storage temperatures accelerate fuel deterioration. Fuel deterioration problems may occur within a few months, or even less if the gasoline was not fresh when you filled the fuel tank.

The Distributor's Limited Warranty does not cover fuel system damage or engine performance problems resulting from neglected storage preparation.

You can extend fuel storage life by adding a gasoline stabilizer that is formulated for that purpose, or you can avoid fuel deterioration problems by draining the fuel tank and carburetor.

#### **Adding a gasoline stabilizer to extend fuel storage life:**

When adding a gasoline stabilizer, fill the fuel tank with fresh gasoline. If only partially filled, air in the tank will promote fuel deterioration during storage. If you keep a container of gasoline for refueling, be sure that it contains only fresh gasoline.

1. Add gasoline stabilizer following manufactures instructions.
2. After adding a gasoline stabilizer, run the engine outdoors for 10 minutes to be sure that treated gasoline has replaced the untreated gasoline in the carburetor.
3. Stop the engine, and leave the throttle lever in the STOP position. This turns OFF the fuel valve between the fuel tank and the carburetor.

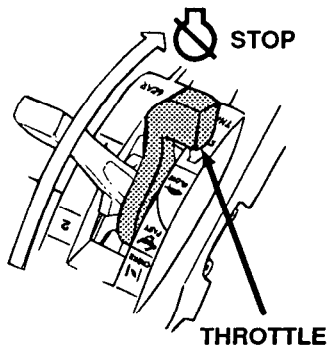

## Draining the Fuel Tank and Carburetor

1. Remove the carburetor drain bolt with a 10 mm wrench, and drain the carburetor bowl fuel into an approved container.

### **⚠ WARNING**

Gasoline is highly flammable and explosive.

You can be burned or seriously injured.

When working on fuel system connections:

- Keep heat, sparks, and flames away.
- Wipe up spills immediately.

2. Move the throttle lever to the SLOW or FAST position to OPEN the fuel valve. This will allow fuel in the fuel tank to drain through the carburetor bowl.
3. Reinstall the drain bolt.

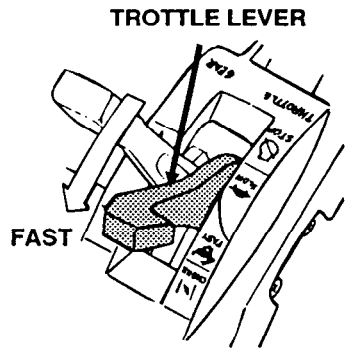
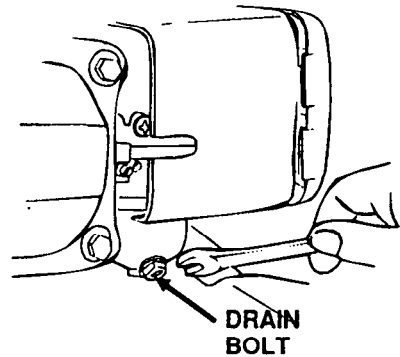

## Engine Oil

1. Change the engine oil (see page 46).
2. Remove the spark plug (see page 49). Pour a tablespoon (5 - 10 cc) of clean engine oil into the cylinder. Pull the starter rope several times to distribute the oil in the cylinder. Reinstall the spark plug.

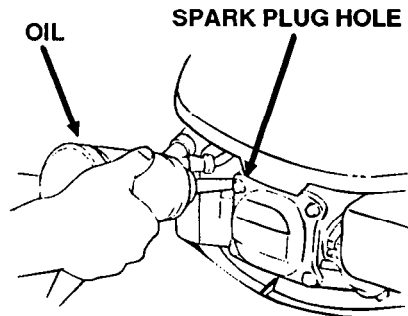

## STORAGE

---

### Storage

If your mower will be stored with gasoline in the fuel tank and carburetor, it is important to reduce the hazard of gasoline vapor ignition. Select a well-ventilated storage area away from any appliance that operates with a flame, such as a furnace, water heater, or clothes dryer. Also avoid any area with a spark-producing electric motor, or where power tools are operated.

If possible, avoid storage areas with high humidity, because that promotes rust and corrosion.

Unless all fuel has been drained from the fuel tank, leave the throttle lever in the OFF position to CLOSE the fuel valve and reduce the possibility of fuel leakage.

Place the mower with its wheels on a level surface. Tilting can cause fuel or oil leakage.

The handlebar can be folded for compact storage:

1. Loosen the handlebar locking knobs.
2. Spread the lower ends of the handlebar struts to release the locking pins.
3. Fold the handlebar forward, over the top of the mower.

When folding the handlebar, be careful to avoid kinking or pinching the control cables.

With the engine and exhaust system cool, cover the mower to keep out dust. A hot engine and exhaust system can ignite or melt some materials. Do not use sheet plastic as a dust cover. A nonporous cover will trap moisture around the mower, promoting rust and corrosion.

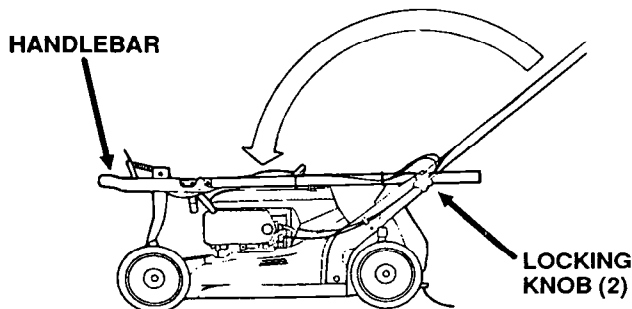

## Removal From Storage

Check your mower as described in the BEFORE MOWING chapter of this manual.

If the fuel was drained during storage preparation, fill the tank with fresh gasoline. If you keep a container of gasoline for refueling, be sure that it contains only fresh gasoline. Gasoline oxidizes and deteriorates over time, causing hard starting.

If the cylinder was coated with oil during storage preparation, the engine will smoke briefly at startup. This is normal.





# SPECIFICATIONS

*This section gives dimensions, capacities, and other technical information.*

<b>Mower Models</b> _____	<b>74</b>
<b>Dimensions and General Specifications</b> _____	<b>74</b>
<b>Engine</b> _____	<b>75</b>
<b>Transmission</b> _____	<b>75</b>

## SPECIFICATIONS

### Mower Models

HRB215PXA: Manually propelled, high-lift blade, and grass bag
HRB215SXA: Self-propelled, high-lift blade, and grass bag
HRM215PXA: Manually propelled, mulching blades, and mulching plug
HRM215SXA: Self-propelled, mulching blades, and mulching plug

### Dimensions and General Specifications

Overall Length	Handlebar high: 1505 mm (59¼ in) Handlebar mid: 1580 mm (62 <sup>3</sup> / <sub>16</sub> in) Handlebar low: 1635mm (64 <sup>3</sup> / <sub>8</sub> in) Handlebar folded: 1062 mm (41 <sup>13</sup> / <sub>16</sub> in)
Overall Height with cutting height adjusted to 64 mm (2½ in)	Handlebar high: 1040 mm (40 <sup>15</sup> / <sub>16</sub> in) Handlebar mid: 985 mm (38 <sup>13</sup> / <sub>16</sub> in) Handlebar low: 925 mm (36 <sup>7</sup> / <sub>16</sub> in) Handlebar folded: 483 mm (19 in)
Width at Mower Deck	580 mm (22 <sup>13</sup> / <sub>16</sub> in)
Cutting Width	530 mm (21 in)
Cutting Height	HRB215 19 mm (¾ in), 25 mm (1 in), 38 mm (1½ in), 51 mm (2 in), 64 mm (2½ in), 76 mm (3 in)  HRM215 25 mm (1 in), 38 mm (1½ in), 51 mm (2 in), 64 mm (2½ in), 76 mm (3 in), 89 mm (3½ in)
Dry Weight	HRB215PXA & HRM215PXA: 40.0 kg (88.2 lb) HRB215SXA & HRM215SXA: 43.0 kg (94.8 lb)
Grass Bag Capacity	83 ℓ (2.4 bushels; 2.9 cu ft; 21.9 US gal)

**Engine**

Engine Model	GXV140
Engine Type	4-stroke, overhead-valve, single cylinder, forced air-cooled
Displacement	135 cc (8.2 cu in)
Bore and Stroke	64 x 42 mm (2.52 x 1.65 in)
Compression Ratio	8:1
Maximum Horsepower	3.3 kW, 4.5 PS, (4.4 bhp) at 3,600 rpm
Maximum Torque	9.0 N·m , 92 kg·cm, (6.6 ft·lb) at 2,700 rpm
Maximum Governed Speed	3,100 ± 150 rpm
Ignition System	Transistorized magneto
Spark Plug	Regular: NGK BP5ES, ND W16EP-U, Champion N12Y Resistor: NGK BPR5ES, ND W16EPR-U, Champion RN12Y
Spark Plug Gap	0.7 - 0.8 mm (0.028 - 0.031 in)
Fuel	Use regular gasoline with a pump octane rating of 86 or higher (p. 24). Unleaded gasoline is recommended.
Fuel Tank Capacity	1.0 l (0.26 US gal, 0.22 Imp gal)
Engine Oil	SAE 10W - 30 is recommended for general, all-temperature use (p. 46)
Engine Oil Capacity	0.6 l (0.63 US qt)

**Transmission**

Transmission Type	2-speed, manual shift
Maximum Self-propelled Speeds	1 (slow): 2.9 km/h (1.8 mph) 2 (fast): 4.7 km/h (2.9 mph)





# INDEX & ADDITIONAL INFORMATION

*This section contains an index, lists additional Honda publications, and tells you how to contact us if you have a question or a warranty repair problem.*

Index _____	78
Honda Publications _____	82
Customer Service Information _____	83

# INDEX & ADDITIONAL INFORMATION

---

## Index

### A

Air Cleaner Inspection . . . . .	26
Air Cleaner Service . . . . .	48
Attachments: Standard and Optional . . . . .	9

### B

Bagging (requires optional grass bag) . . . . .	39
Blade(s):	
Inspection . . . . .	21
Installation . . . . .	59
Removal . . . . .	58
Sharpness . . . . .	37
Standard and Optional Types . . . . .	8
Blade Control Lever:	
Cable Adjustment . . . . .	54
Operation . . . . .	15 & 32

### C

Carburetor:	
Adjustment . . . . .	52
Modification for High Altitude . . . . .	53
Choke . . . . .	14 & 30
Clogged Mower Deck . . . . .	38
Clothing Recommendations . . . . .	28
Component Identification . . . . .	12
Contents . . . . .	IV
Control Cable Adjustments:	
Blade Control Lever . . . . .	54
Drive Clutch Lever . . . . .	55
Gear Shift Lever . . . . .	57
Throttle Lever . . . . .	56
Controls: Operation . . . . .	14 & 31
Customer Service Information . . . . .	83
Cutting Height:	
Adjustment Levers . . . . .	18
Recommendations . . . . .	36
Cutting Width Recommendations . . . . .	36

**D**

Damage Prevention Message Definition . . . . .	III
Drive Clutch Lever (HRB215SXA & HRM215SXA):	
Cable Adjustment . . . . .	55
Operation . . . . .	16 & 32

**E**

## Engine:

Fuel Recommendations . . . . .	24
Maintenance . . . . .	46
Oil Change . . . . .	46
Oil Level Check . . . . .	22
Oil Recommendations . . . . .	22 & 46
Refueling . . . . .	23
Serial Number . . . . .	13
Starting . . . . .	30
Stopping . . . . .	33
Troubleshooting . . . . .	62

**F**

Fallen Leaves: Mulching, Raking, Bagging . . . . .	38
Frame Serial Number . . . . .	13
Fuel:	
Additive to Extend Storage Life . . . . .	68
Gasoline Recommendations . . . . .	24
Draining . . . . .	69
Refueling . . . . .	23

**G**

Gasoline Recommendations . . . . .	24
Gear Shift Lever (HRB215SXA & HRM215SXA):	
Cable Adjustment . . . . .	57
Operation . . . . .	14 & 31
Grass Bag (standard for HRB215):	
Cleaning . . . . .	60
Inspection . . . . .	27
Removal and Installation . . . . .	9
Replacement . . . . .	60

## INDEX & ADDITIONAL INFORMATION

---

### H

Handlebar Height Adjustment & Folding . . . . .	17
High Altitude Operation: Recommended Modifications . . . . .	53
High-Lift Blade (standard for HRB215) . . . . .	8

### I

Inspection Before Mowing:	
Lawn . . . . .	20
Mower . . . . .	21
Introduction . . . . .	II

### L

Lawn:	
Inspection Before Mowing . . . . .	20
Mowing Tips . . . . .	36
Safe Mowing Practices . . . . .	34
Leaves: Mulching, Raking, Bagging . . . . .	38

### M

Maintenance:	
Blade(s) Removal and Installation . . . . .	58
Cable Adjustments . . . . .	54
Engine . . . . .	46
Grass Bag Cleaning & Replacement . . . . .	60
Precautions . . . . .	44
Schedule . . . . .	45
Mower Deck Clogging . . . . .	38
Mowing:	
Around Obstacles, Gravel, Objects . . . . .	35
Dry & Wet Grass . . . . .	37
Fallen Leaves . . . . .	38
Patterns . . . . .	39
Slopes . . . . .	34
Tips . . . . .	36
When to Mow . . . . .	36
Mulching . . . . .	39
Mulching Blade, 2-Piece (standard for HRM215)	8
Mulching Plug Removal & Installation . . . . .	9

**O**

## Oil (for engine):

Change . . . . .	46
Level Check . . . . .	22
Recommendations . . . . .	22 & 46

**P**

## Pre-Operation Check:

Lawn . . . . .	20
Mower . . . . .	21

**S**

## Safety:

Important Message to Parents . . . . .	4
Safe Mowing Practices . . . . .	34
Safety Information . . . . .	2
Safety Label Locations . . . . .	5
Safety Message Definitions . . . . .	III

## Serial Numbers . . . . . 13

## Shift Lever (HRB215SXA &amp; HRM215SXA):

Cable Adjustment . . . . .	57
Operation . . . . .	14 & 31

## Side-Discharge Chute (optional equipment)

Removal and Installation . . . . .	10
------------------------------------	----

## Side-Discharge Mowing (requires

optional side-discharge chute) . . . . .	39
--	----

## Spark Arrester Service

(optional equipment) . . . . .	51
--------------------------------	----

## Spark Plug Recommendations &amp; Service . . . 49

## Specifications:

Dimensions . . . . .	74
Engine . . . . .	75
Transmission . . . . .	75

## Starting the Engine . . . . . 30

## Stopping the Engine . . . . . 33

## Storage:

Preparation . . . . .	66
Removal From Storage . . . . .	71
Storage Area . . . . .	70

## INDEX & ADDITIONAL INFORMATION

---

### T

#### Throttle Lever:

Cable Adjustment . . . . .	56
Operation . . . . .	14 & 31

Transporting . . . . .	42
------------------------	----

#### Troubleshooting:

Engine Problems . . . . .	62
Mowing/Mulching/Bagging Problems . . . . .	63
Vibration Problems . . . . .	63

### W

#### Washing:

Grass Bag (standard on HRB215) . . . . .	60
Mower . . . . .	66

## Honda Publications

These publications will give you additional information for maintaining and repairing your mower. You may order them from your Honda lawn mower dealer.

### Shop Manual

This manual covers complete maintenance and overhaul procedures. It is intended to be used by a skilled technician.

### Parts Catalog

This manual provides complete, illustrated parts lists.

## **Customer Service Information**

Honda Power Equipment dealership personnel are trained professionals. They should be able to answer any question you may have. If you encounter a problem that your dealer does not solve to your satisfaction, please discuss it with the dealership's management. The Service Manager or General Manager can help. Almost all problems are solved in this way.

If you are dissatisfied with the decision made by the dealership's management, contact the Honda Power Equipment Customer Service Office. You can write:

**American Honda Motor Co., Inc.**  
Honda Power Equipment Division  
Customer Service Office  
4475 River Green Parkway  
Duluth, GA 30136-2565

Or telephone: (404) 497-6400

When you write or call, please give us this information:

- Model and serial numbers (see pages 12 & 13)
- Name of the dealer who sold the lawn mower to you
- Name and address of the dealer who services your lawn mower
- Date of purchase
- Your name, address, and telephone number
- A detailed description of the problem



## **Current customer service contact information:**

### **United States, Puerto Rico, and U.S. Virgin Islands:**

Honda Power Equipment dealership personnel are trained professionals. They should be able to answer any question you may have. If you encounter a problem that your dealer does not solve to your satisfaction, please discuss it with the dealership's management. The Service Manager or General Manager can help. Almost all problems are solved in this way.

If you are dissatisfied with the decision made by the dealership's management, contact the Honda Power Equipment Customer Relations Office. You can write:

American Honda Motor Co., Inc.  
Power Equipment Division  
Customer Relations Office  
4900 Marconi Drive  
Alpharetta, GA 30005-8847

Or telephone: (770) 497-6400 M-F, 8:30 am - 7:00 pm EST

When you write or call, please provide the following information:

- Model and serial numbers
- Name of the dealer who sold the Honda power equipment to you
- Name and address of the dealer who services your equipment
- Date of purchase
- Your name, address, and telephone number
- A detailed description of the problem

# **HONDA**

31VEZA10  
00X31-VEZ-A10

**CPI** 60009304  
PRINTED IN U.S.A.