

HONDA

Power

Equipment

Owner's Manual

Rotary Mower

HRM215SDA • HRM215PDA

HRB215SDA • HRB215PDA



HONDA

Harmony



WARNING:



The engine exhaust from this product contains chemicals known to the State of California to cause cancer, birth defects or other reproductive harm.

Congratulations on your selection of a Honda lawn mower. We are certain you will be pleased with your purchase of one of the finest lawn mowers on the market.

We want to help you get the best results from your new mower and to operate it safely. This manual contains the information on how to do that; please read it carefully.

We suggest you read the warranty policy to fully understand its coverage and your responsibilities of ownership. The warranty policy is a separate document that should have been given to you by your dealer.

When your mower needs scheduled maintenance, keep in mind that an authorized Honda servicing dealer is specially trained in servicing Honda mowers and is supported by the parts and service divisions of American Honda. Your Honda dealer is dedicated to your satisfaction and will be pleased to answer your questions and concerns.

Best Wishes,
Power Equipment Division
American Honda Motor Co., Inc.

INTRODUCTION

SAFETY MESSAGES

Your safety and the safety of others is very important. We have provided important safety messages in this manual and on the lawn mower. Please read these messages carefully.

A safety message alerts you to potential hazards that can hurt you and others. Each safety message is preceded by a safety alert symbol  and one of three words: DANGER, WARNING, or CAUTION.

These mean:

 **DANGER**

You **WILL** be **KILLED** or **SERIOUSLY HURT** if you don't follow instructions.

 **WARNING**

You **CAN** be **KILLED** or **SERIOUSLY HURT** if you don't follow instructions.

 **CAUTION**

You **CAN** be **HURT** if you don't follow instructions.

Each message tells you what the hazard is, what can happen, and what you can do to avoid or reduce injury.

DAMAGE PREVENTION MESSAGES

You will also see other important messages that are preceded by the word NOTICE.

This word means:

NOTICE

Your lawn mower or other property can be damaged if you don't follow instructions.

The purpose of these messages is to help prevent damage to your lawn mower, other property, or the environment.

CONTENTS

Turn to the beginning of each chapter for a complete list of subjects.

| | |
|---|-------------------|
| MOWER SAFETY | 5 |
| Important information about some specific hazards, and what you can do to prevent injury. | |
| CONTROLS | 9 |
| Identification of components and information about how the controls work. | |
| BEFORE OPERATION | 15 |
| How to fuel and check your mower to be sure it is ready. How to prepare your lawn and yourself before you begin mowing. | |
| OPERATION | 25 |
| Starting and stopping the engine, safe mowing practices, and mowing tips. | |
| TRANSPORTING | 37 |
| How to load and carry your mower safely. | |
| MAINTENANCE | 39 |
| When and how to perform routine inspection, service, and adjustments to keep your mower in good operating condition. | |
| TROUBLESHOOTING | 59 |
| What to check if you have a problem with your mower. | |
| STORAGE | 63 |
| How to protect your mower from rust and corrosion, and ensure that it will start easily when you want to use it again. | |
| SPECIFICATIONS | 71 |
| Dimensions, capacities, and other technical information. | |
| ADDITIONAL INFORMATION | 75 |
| Additional information, Honda publications available to you, and how to contact us if you have a question or a warranty repair problem. | |
| INDEX | 81 |
| Quick Reference Information | inside back cover |

MOWER SAFETY

This chapter explains what you need to know to operate your mower safely.

| | |
|---|----------|
| IMPORTANT SAFETY INFORMATION | 6 |
| Avoid Rotating Blades | 6 |
| Clear Mowing Area | 6 |
| Keep Shields in Place | 6 |
| Refuel with Care. | 6 |
| Wear Protective Clothing | 6 |
| Turn Engine Off When Not Mowing | 6 |
| IMPORTANT MESSAGE TO PARENTS | 7 |
| SAFETY LABEL LOCATIONS | 8 |

MOWER SAFETY

IMPORTANT SAFETY INFORMATION

Most accidents with walk-behind mowers can be prevented if you follow all instructions in this manual and on the mower. The most common hazards, according to accident statistics, are discussed below, along with the best way to protect yourself and others.

Avoid Rotating Blades

Rotating blades can cause serious cuts and even amputate fingers, hands, toes, or feet. Keep away from the mower deck whenever the engine is running. If you need to adjust the cutting height, or work around the deck for any other reason, always shut off the engine. Wear heavy gloves and disconnect the spark plug cap when you need to clean the mower deck or handle the blade(s).

Clear Mowing Area

Mower blades can throw rocks and other objects with enough force to cause serious injury. Before mowing, carefully inspect the area and remove all sticks, stones, pieces of wire, and other loose objects. Never operate the blade(s) over gravel.

Keep Shields in Place

Guards and shields are designed to protect you from being hit by thrown objects and from hot engine parts and moving components. For your safety and the safety of others, keep all shields in place when the engine is running.

Refuel with Care

Gasoline is extremely flammable and gasoline vapor can explode. Refuel only outdoors, in a well-ventilated area, with the engine OFF. Never smoke near gasoline, and keep other flames and sparks away. Always store gasoline in an approved container.

Wear Protective Clothing

Wearing protective clothing will reduce your risk of injury. Long pants and eye protection reduce the risk of injuries from thrown objects. Sturdy shoes with aggressive soles will help protect your feet and give you better traction on slopes or uneven ground.

Turn Engine Off When Not Mowing

If you need to leave the mower for any reason, even just to inspect the lawn ahead, always turn the engine off.

IMPORTANT MESSAGE TO PARENTS

YOUR CHILDREN'S SAFETY IS VERY IMPORTANT to Honda. That's why we urge you to read this message before letting your youngster operate this lawn mower. Lawn mowers are tools, not toys. As with any equipment, bad judgments can result in serious injuries. You can help prevent accidents by making good decisions about if, when, and how your youngster operates this equipment.

The first question you'll need to ask is whether your youngster is capable of operating this mower safely. Remember, young people vary widely, and **AGE IS NOT THE ONLY FACTOR**.

Physically, a youngster must be **LARGE ENOUGH AND STRONG ENOUGH** to easily start the mower and control its direction. The youngster also needs enough size, strength, and coordination to comfortably reach and operate the controls.

Another, tougher question you need to ask is if your youngster has enough **MATURITY AND RESPONSIBILITY** to safely operate this mower. Does the young person think through problems and come to logical solutions? Be honest! Anyone who takes unnecessary risks and doesn't obey rules should not operate this lawn mower.

If you decide that your son or daughter can handle the mower safely, **CAREFULLY READ THE OWNER'S MANUAL** with your youngster. Make sure you both understand all instructions and safety information. Also, be sure your youngster wears sturdy shoes and other protective clothing when operating or handling the mower.

SUPERVISION is also very important. Walk with your youngster during the first few minutes of mowing. Even after the youngster has become confident with the mower, do not let the young person use the mower without good adult supervision. An adult should also be present during refueling and maintenance. In fact, it's up to parents to make sure that the mower is properly maintained and kept in safe operating condition.

By always placing safety first, your youngster will acquire useful skills and a sense of accomplishment. And you'll both get the best results from your lawn mower.

MOWER SAFETY

SAFETY LABEL LOCATIONS

The labels shown here contain important safety information. Please read them carefully. These labels are considered permanent parts of your mower. So if a label comes off or becomes hard to read, contact an authorized Honda dealer for a replacement.

(HRB215)

⚠ CAUTION

UNDER NORMAL USAGE, THIS BAG MATERIAL IS SUBJECT TO DETERIORATION AND WEAR, AND SHOULD BE CHECKED FREQUENTLY FOR BAG REPLACEMENT. THIS BAG CONFORMS TO A.N.S.I. STANDARD B71.1, ANY REPLACEMENT MUST MEET THIS STANDARD.

⚠ WARNING

Gasoline is highly flammable and explosive and you can be burned or seriously injured.

When refueling:

- Keep heat, sparks, and open flame away.
- Fill fuel tank only outdoors.
- Wipe up spills before starting engine.

⚠ WARNING

MOWER BLADE CAN CUT OFF HANDS OR FEET

- Stop engine before opening rear door.
- Always keep feet away from mower deck.

THROWN OBJECTS CAN CAUSE SERIOUS INJURY, BLINDNESS, OR PROPERTY DAMAGE

- Inspect area and remove debris before mowing.
- Keep children and others away.
- Wear eye protection.
- Follow all instructions in your Owner's Manual carefully.

⚠ DANGER

KEEP HANDS and FEET AWAY



⚠ CAUTION

HOT MUFFLER CAN BURN YOU.
Stay away if engine has been running.

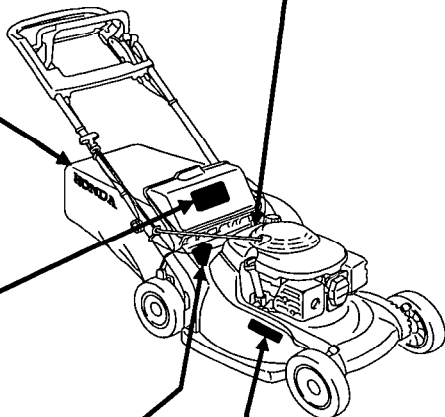

CONTROLS

This chapter shows the locations of controls and other important parts of your mower, and it tells you how the controls work.

| | |
|--|-----------|
| COMPONENT IDENTIFICATION | 10 |
| DESCRIPTION OF CONTROLS | 12 |
| Throttle Lever | 12 |
| Flywheel Brake Lever | 13 |
| Drive Clutch Lever (SDA) | 13 |
| Shift Lever (SDA) | 14 |
| Cutting Height Adjustment Levers | 14 |

CONTROLS

COMPONENT IDENTIFICATION

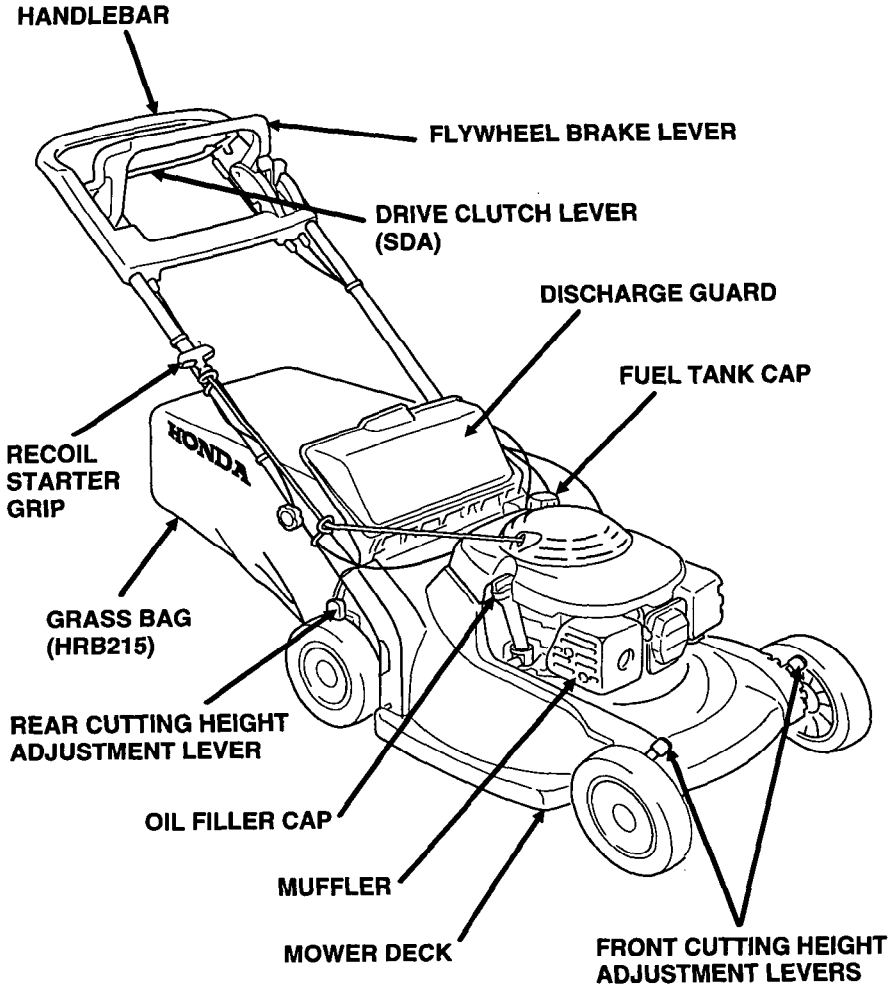

VE1NABAC.CDR

HRB215PDA: Manually propelled, high-lift blade, and grass bag.

HRB215SDA: Self-propelled, high-lift blade, and grass bag.

HRM215PDA: Manually propelled, mulching blades, and mulching plug.

HRM215SDA: Self-propelled, mulching blades, and mulching plug.

CONTROLS

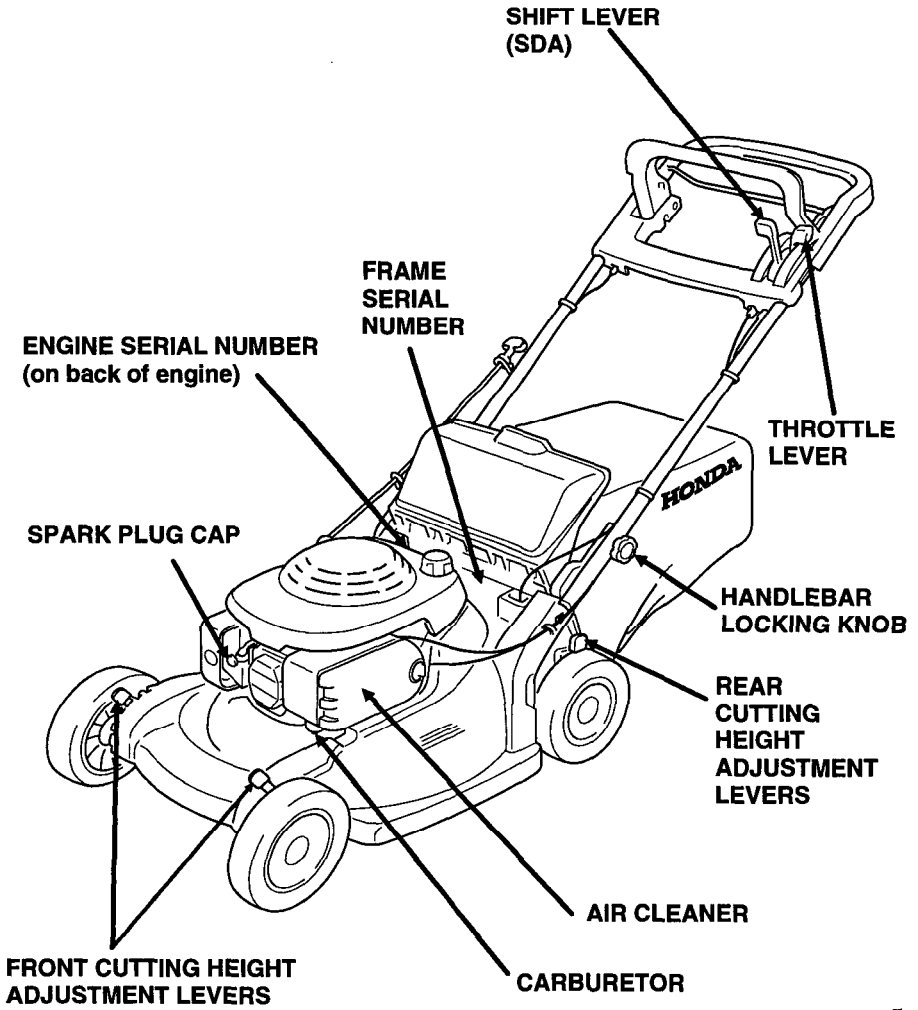

Record the frame and engine serial numbers in the space below. You will need these serial numbers when ordering parts and when making technical or warranty inquiries (see page 77).

Frame serial number: MZB__ - _____

Engine serial number: GJAB - _____

CONTROLS

DESCRIPTION OF CONTROLS

Throttle Lever



CHOKE -- For starting a cold engine.



FAST --- For restarting a warm engine and for mowing.



SLOW --- For idling the engine.

**FUEL
VALVE
OFF**

----- For closing the fuel valve (releasing the flywheel brake lever turns off the engine).

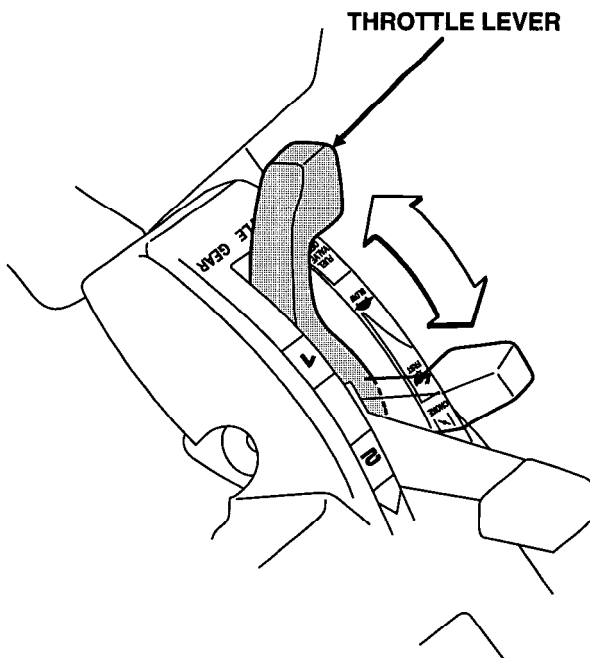

Flywheel Brake Lever

This lever is connected to the engine flywheel brake and the ignition switch. The engine will not start unless this lever is pulled back.

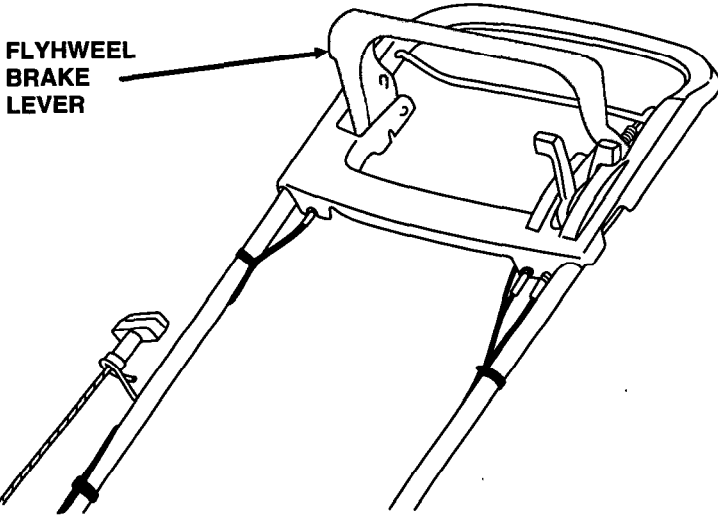

VE20CAB.CDR

Drive Clutch Lever (SDA)

The drive clutch lever engages and disengages the transmission that drives the rear wheels.

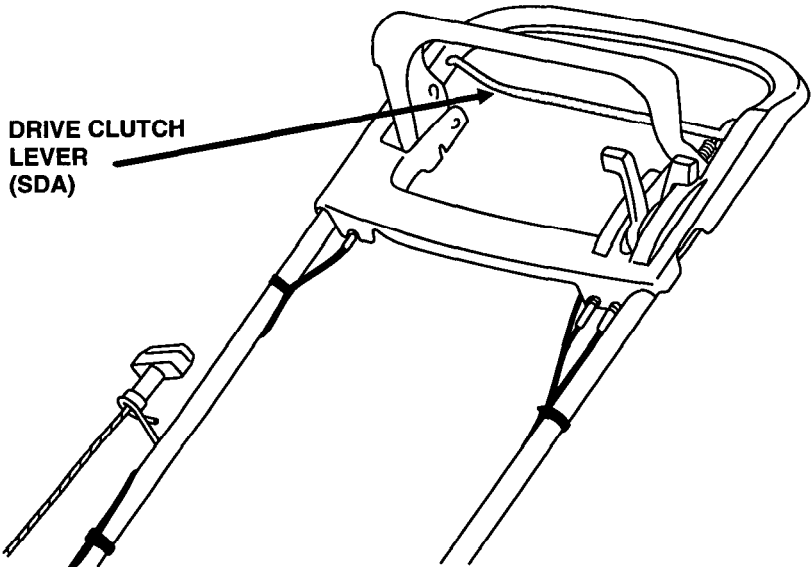

VE20CAB.CDR

CONTROLS

Shift Lever (SDA)

The shift lever selects and controls the mower's drive speed.

- 1 (SLOW) – For mowing thick grass or maneuvering in small areas.
- 2 (FAST) — For maximum self-propelled speed in large, open areas, and for transport.

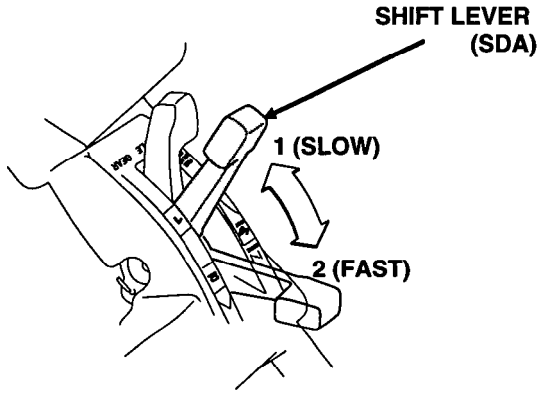

VE2CABAC.CDR

Cutting Height Adjustment Levers

There are six settings to choose from, as shown in the illustration. The cutting height figures are approximate. The actual height of cut grass will vary with lawn and soil conditions. There is an adjustment lever on each wheel.

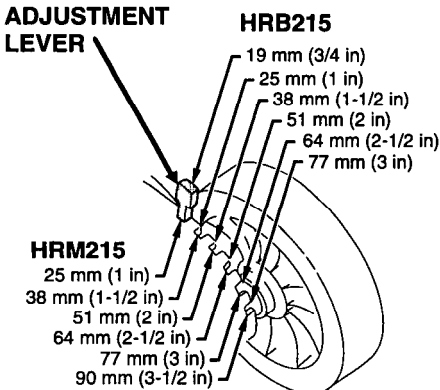

ADJUSTMENT LEVERS

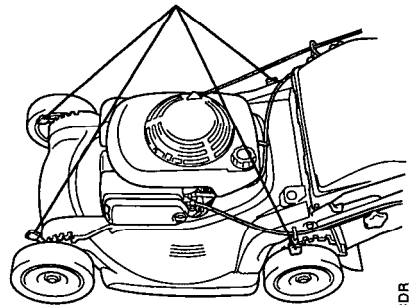

VE2CADAA.CDR

VE2CAEAA.CDR

BEFORE OPERATION

This chapter explains how to fuel and check your mower to be sure it is ready, and it tells you how to prepare your lawn and yourself before you begin mowing.

| | |
|----------------------------------|-----------|
| CHECK YOUR LAWN | 16 |
| Objects..... | 16 |
| People and Pets..... | 16 |
| Lawn..... | 16 |
| CHECK YOUR MOWER | 17 |
| Blade(s)..... | 17 |
| Engine Oil Level..... | 18 |
| Fuel..... | 19 |
| Air Cleaner Inspection..... | 20 |
| Handlebar Height Adjustment..... | 21 |
| Grass Bag (HRB215)..... | 22 |
| Inspection..... | 22 |
| Installation..... | 22 |
| Removal..... | 22 |
| Mulching Plug (HRM215)..... | 23 |
| Cutting Height..... | 23 |
| Are YOU Ready to Mow?..... | 24 |

BEFORE OPERATION

CHECK YOUR LAWN

For your safety and for the safety of others, always inspect the area before mowing.

Objects

Anything which can be picked up by the blade(s) and thrown is a potential hazard to you and others. Look for things like stones, sticks, bones, and wire. Remove them from the mowing area.

People and Pets

People and animals near the mowing area can move into your path or into a position where they could be struck by thrown objects. Clear the area of people and pets, especially children. Their safety is your responsibility.

Lawn

Check the length and condition of the grass, so you will know what cutting height and mowing speed to use.

Avoid mowing wet grass. Not only will wet grass clog your mower deck and collect in clumps on the lawn, it also gives poor traction, increasing your risk of losing your footing.

CHECK YOUR MOWER

Blade(s)

With the throttle lever in the FUEL VALVE OFF position, and the spark plug cap disconnected, tilt the mower to the right, so the carburetor side is up. This will help to prevent fuel leakage and hard starting.

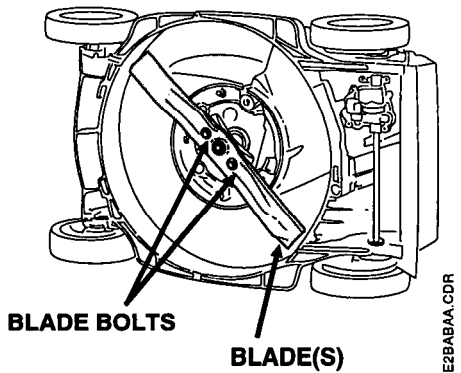

VE2BABAA.CDR

Inspect the blade(s) for wear and damage.



NORMAL



**EXCESSIVELY
WORN**



BENT



CRACKED

LM-AACAA.CDR

A dull blade can be sharpened, but a blade that is worn out, bent, cracked, or otherwise damaged must be replaced. A worn or damaged blade can break, causing blade pieces to be thrown from the mower.

When a blade needs sharpening or replacement take the lawn mower to an authorized Honda servicing dealer. Or, if you have a torque wrench, you can remove and install a blade yourself (see pages 56 - 57).

Check that the blade bolts are tight (see page 57).

BEFORE OPERATION

Engine Oil Level

Check the engine oil level with the engine stopped and the mower on a level surface.

1. Remove the oil filler cap, and wipe the dipstick clean.

2. Insert and remove the dipstick without screwing it into the filler neck. Check the oil level shown on the dipstick.

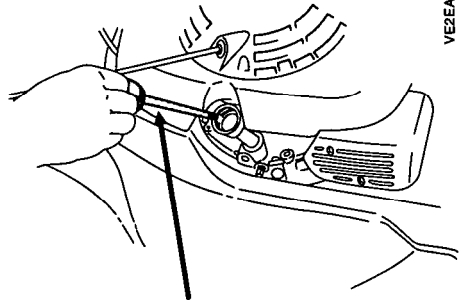

VE2EAAA.CDR

FILLER CAP/DIPSTICK

3. If the oil level is low, add oil to reach the upper limit mark on the dipstick. Do not overfill.

4. After checking the engine oil level, screw in the filler cap/dipstick securely.

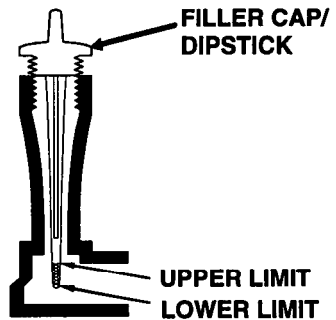

FILLER CAP/
DIPSTICK

UPPER LIMIT
LOWER LIMIT

LM-A0AA.CDR

Fuel

Fuel tank capacity: 1.0 ℓ (0.26 US gal)

Refuel in a well-ventilated area before starting the engine. If the engine has been running, allow it to cool. Refer to page 51 for fuel recommendations and page 78 for information about oxygenated fuels.

Remove the fuel tank cap and check the fuel level. Refill the tank if the fuel level is low. Refuel carefully to avoid spilling fuel. Do not overfill; there should be no fuel in the filler neck. After refueling, tighten the fuel tank cap securely.

⚠ WARNING

Gasoline is highly flammable and explosive and you can be burned or seriously injured when refueling.

- Stop engine and keep heat, sparks, and flame away.
- Refuel only outdoors.
- Wipe up spills immediately.

Never refuel the mower inside a building where gasoline fumes may reach flames or sparks. Keep gasoline away from appliance pilot lights, barbecues, electric appliances, power tools, etc.

Spilled fuel is not only a fire hazard, it causes environmental damage. Wipe up spills immediately.

NOTICE

Fuel can damage paint and plastic. Be careful not to spill fuel when filling your fuel tank. Damage caused by spilled fuel is not covered under warranty.

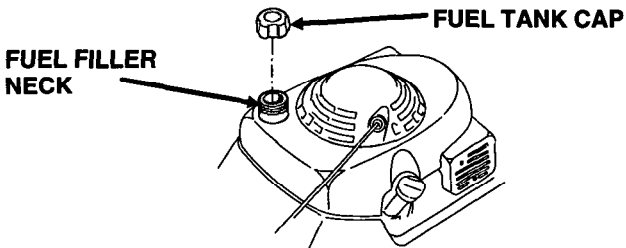

BEFORE OPERATION

Air Cleaner Inspection

Check that the air filters are clean and in good condition. Dirty air filters will restrict air flow to the carburetor, reducing engine performance. Refer to page 47 for air cleaner service.

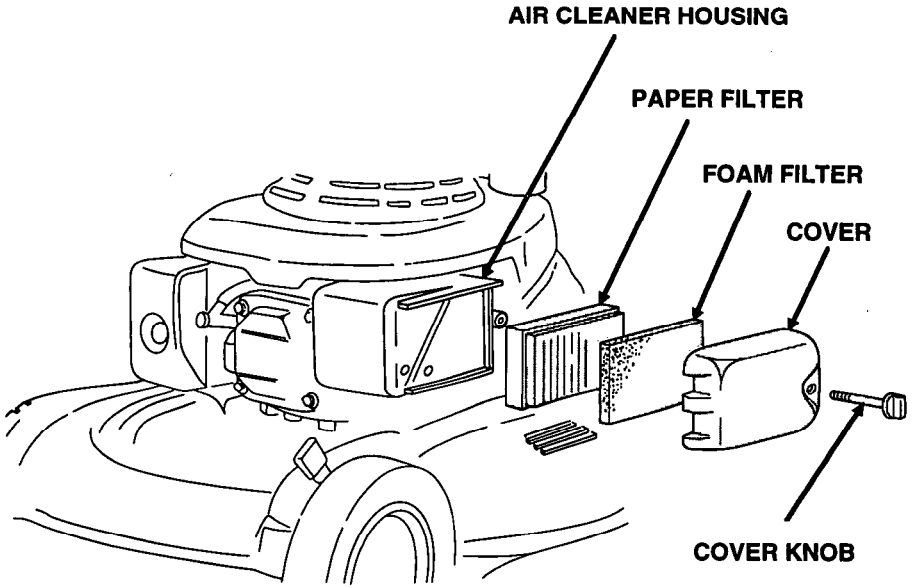

Handlebar Height Adjustment

Adjust handlebar height for a comfortable operating position.

1. Loosen the handlebar locking knobs.
2. Spread the lower ends of the handlebars to release the locating pins.
3. Move the handlebar up or down, so the locating pins engage other holes on the handlebar mounting brackets.
4. Tighten the handlebar locking knobs securely.

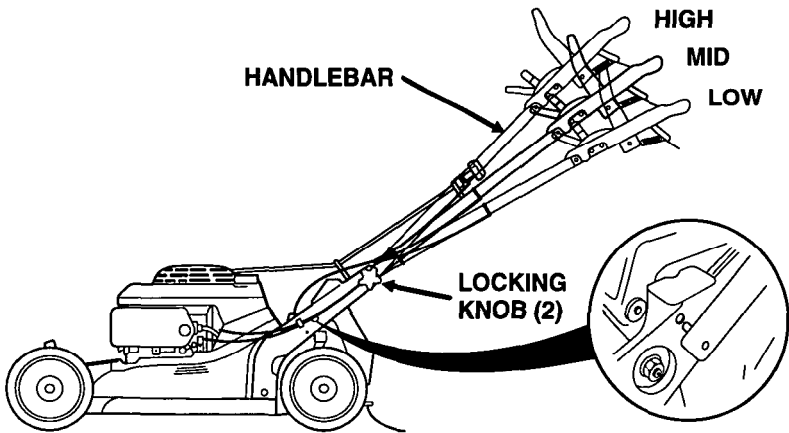

VE2SAAB.CDR

BEFORE OPERATION

Grass Bag (HRB215)

A lawn mower works like a vacuum cleaner; it blows air through the bag, which traps the grass clippings. Always empty the grass bag before it becomes filled to the limit of its capacity. Bagging performance will diminish after the bag becomes about 90% filled. Also, the bag is easier to empty when it is not packed full.

Inspection

Inspect the grass bag for tears, holes, and excessive wear. The grass bag wears during normal use and will eventually require replacement. Grass bag replacement is explained on page 58.

Installation

1. Raise the discharge guard, and hook the grass bag onto the mower deck as shown.
2. Release the discharge guard to secure the grass bag.

Removal

1. Raise the discharge guard, grasp the grass bag handle and remove the grass bag.
2. Release the discharge guard.
3. When the grass bag is clear of the discharge guard, you can lift it through the handlebar opening, or you can remove it to the rear of the mower below the handlebar.

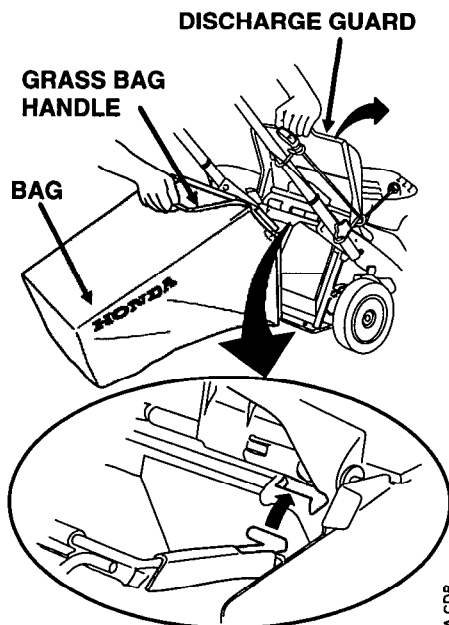

Mulching Plug (HRM215)

The mulching plug contours the mower deck for efficient mulching.

You can quickly remove the plug to install a grass bag or side-discharge chute, which are available as optional equipment.

Raise the discharge guard to remove or install the mulching plug. When installing, be sure the plug is fully inserted, and the discharge guard is closed.

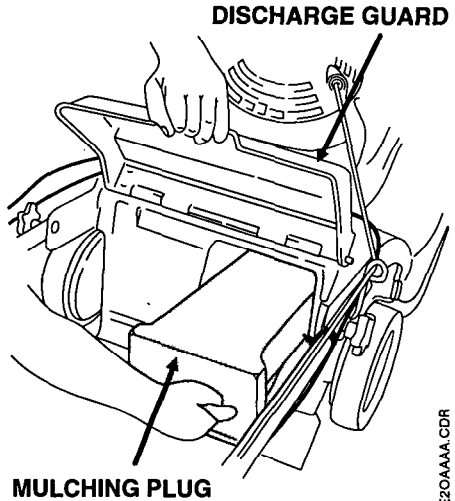

VE20AAA.CDR

Cutting Height

Check the mower deck cutting height settings, and be sure that all four adjustment levers are set to the same cutting height position.

ADJUSTMENT LEVERS

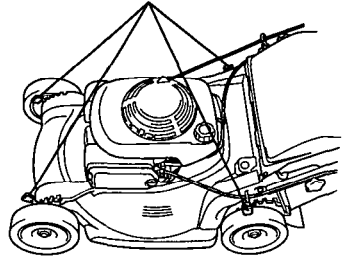

VE2CADAA.CDR

To adjust cutting height, pull each adjustment lever toward the wheel, and move it into another notch.

If you are not sure what cutting height to select, start with a high setting and check the appearance of the lawn after mowing a small area. Then readjust cutting height if necessary.

ADJUSTMENT LEVER

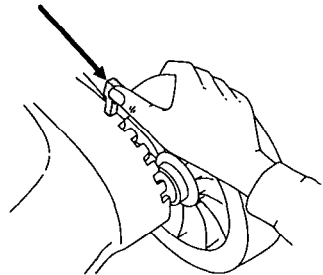

VE2CAEAAA.CDR

BEFORE OPERATION

ARE YOU Ready to Mow?

Be sure to wear protective clothing. Long pants and eye protection can lower your risk of injury from thrown objects. Wear footwear that protects your feet and won't let you slip if you mow on slopes or uneven ground.

OPERATION

This chapter tells you how to operate the mower safely and effectively.

| | |
|--|-----------|
| MOWING PRECAUTIONS | 26 |
| STARTING THE ENGINE | 26 |
| OPERATING THE CONTROLS FOR MOWING | 28 |
| Throttle Lever | 28 |
| Flywheel Brake Lever | 28 |
| Drive Clutch Lever (SDA) | 29 |
| Shift Lever (SDA) | 29 |
| STOPPING THE ENGINE | 30 |
| SAFE MOWING PRACTICES | 31 |
| Slopes | 31 |
| Obstacles | 32 |
| Gravel and Loose Objects | 32 |
| MOWING TIPS | 33 |
| When to Mow | 33 |
| Cutting Height | 33 |
| Cutting Width | 33 |
| Blade Speed | 34 |
| Blade Sharpness | 34 |
| Dry Grass | 34 |
| Wet Grass | 34 |
| Fallen Leaves | 34 |
| Clogged Mower Deck | 34 |
| Mowing Patterns | 35 |
| Mulching | 35 |
| Bagging | 35 |
| Side-Discharge Mowing | 35 |

OPERATION

MOWING PRECAUTIONS

Before operating the mower for the first time, please review the *IMPORTANT SAFETY INFORMATION* beginning on page 6 and the previous chapter, titled *BEFORE OPERATION*.

Even if you have operated other mowers, take time to become familiar with how this mower works and practice in a safe area until you build up your skills.

For your safety, avoid starting or operating the engine in an enclosed area such as a garage. Your mower's exhaust contains poisonous carbon monoxide gas which can collect rapidly in an enclosed area and cause illness or death.

STARTING THE ENGINE

The blade turns when you operate the starter. It is easiest to start the engine in a clear or mowed area where the blade can turn freely.

1. Move the throttle lever to the proper starting position.

COLD ENGINE:

Move the throttle lever to the **CHOKE** position.

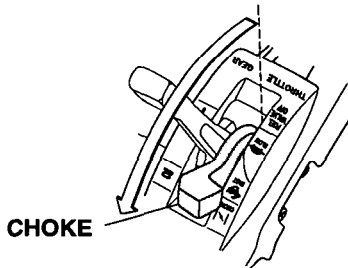

VE2CAAE.CDR

WARM ENGINE:

Move the throttle lever to the **FAST** position.

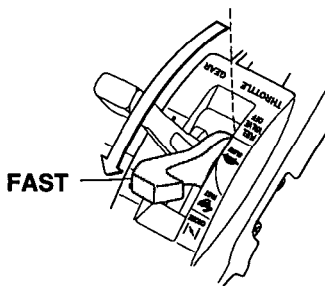

VE2CAAF.CDR

2. **HRB215SDA & HRM215SDA:** Release the drive clutch lever. If the drive clutch lever is engaged, the mower will move forward when you operate the starter.

3. Pull back on the flywheel brake lever back and hold it against the handlebar.
4. Pull the starter grip lightly until you feel resistance, then pull briskly. Return the starter grip gently.

Keep your hands and feet away from the mower deck at all times when starting and running the engine.

Continue to hold the flywheel brake lever against the handlebar; the engine will stop if you release the lever.

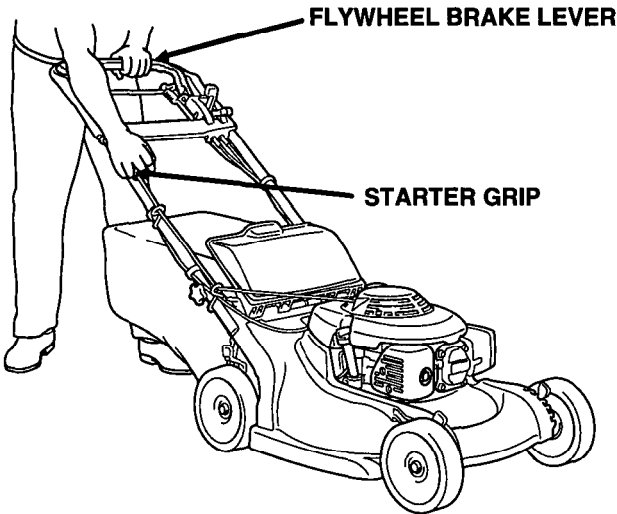

5. If the CHOKE position was used during starting, move the throttle lever away from the CHOKE position as soon as the engine warms up enough to run smoothly. Set the throttle lever at FAST to mow or at SLOW to idle.

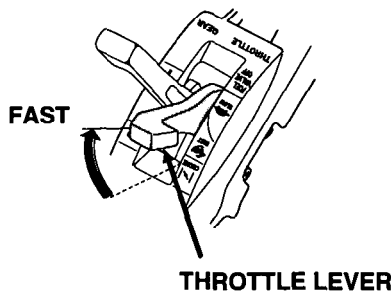

OPERATION

OPERATING THE CONTROLS FOR MOWING

Throttle Lever

For best cut quality, always mow with the throttle lever in the FAST position. When the blade rotates at the preset fast speed, it creates a strong fan action that lifts and cuts grass more efficiently. Do not try to increase the preset engine speed, the blade could fracture and come apart.

When you need to empty the grass bag or leave the mower for any reason, move the throttle lever to the FUEL VALVE OFF position.

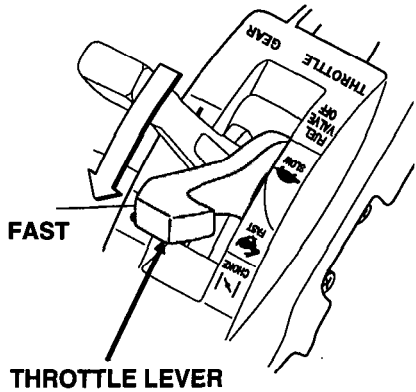

VE2CASAA.CDR

Flywheel Brake Lever

The lever must be pulled back against the handlebar to start the engine. The blade starts to rotate when the lever is pulled back against the handlebar and the recoil starter grip is pulled. Continue to hold the lever against the handlebar to keep the engine running and the blade rotating.

Release the lever to stop the engine and stop blade rotation.

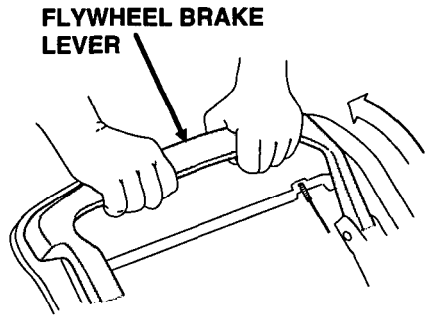

VE2CARAB.CDR

Drive Clutch Lever (SDA)

Pull the drive clutch lever up to propel the mower forward.

Release the drive clutch lever to stop the mower's forward movement.

Always release the drive clutch lever before starting the engine. If the drive clutch is engaged, the mower will move forward when you operate the starter.

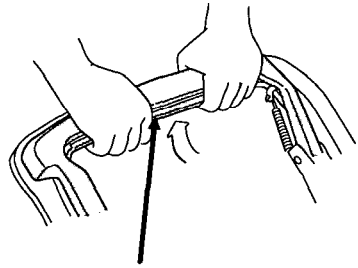

DRIVE CLUTCH LEVER
(SDA)

VE2CARAB.CDR

Operate the drive clutch lever with a quick and complete motion, so the drive clutch is either fully engaged or released. Hold the drive clutch lever against the handlebar during self-propelled mowing. This will help to extend the service life of the clutch mechanism.

Shift Lever (SDA)

Use the shift lever to select the forward speed at which you wish to mow.

You can shift gears without releasing the drive clutch lever, but the transmission may not shift smoothly if the mower is pulling hard. For smoother operation, release the drive clutch lever before shifting gears.

To avoid incomplete gear engagement, move the shift lever all the way forward or all the way back.

Do not use the throttle lever to adjust your forward speed. The throttle lever must remain in the FAST position for good mowing performance. Otherwise, cut quality suffers.

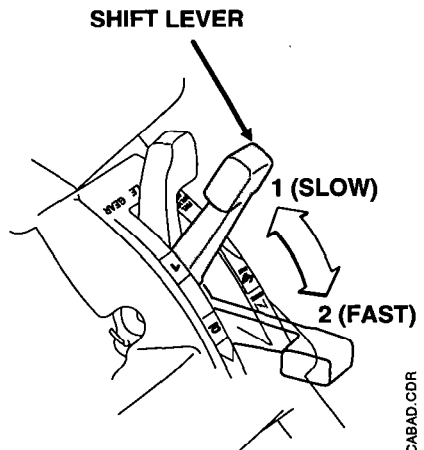

VE2CABAD.CDR

OPERATION

STOPPING THE ENGINE

1. Release the flywheel brake lever and the drive clutch lever (SDA).

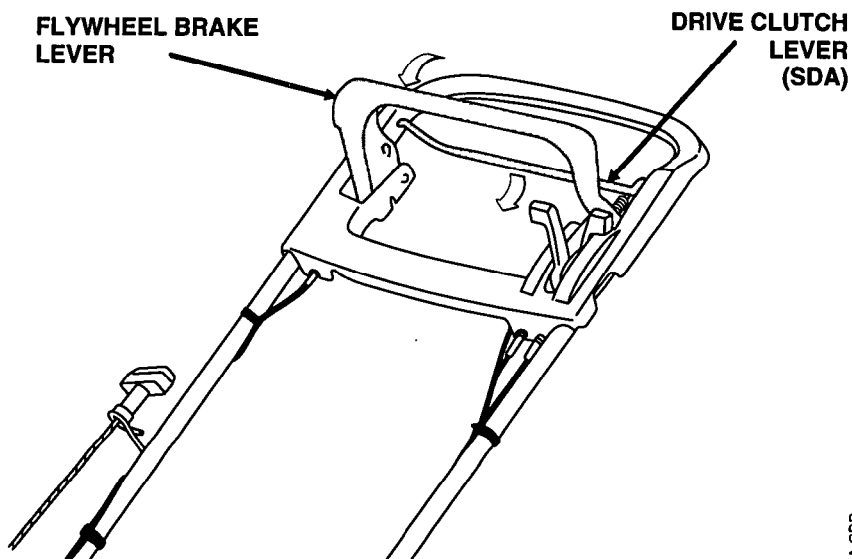

VE2CAUAA.CDR

2. Move the throttle lever to the FUEL VALVE OFF position.

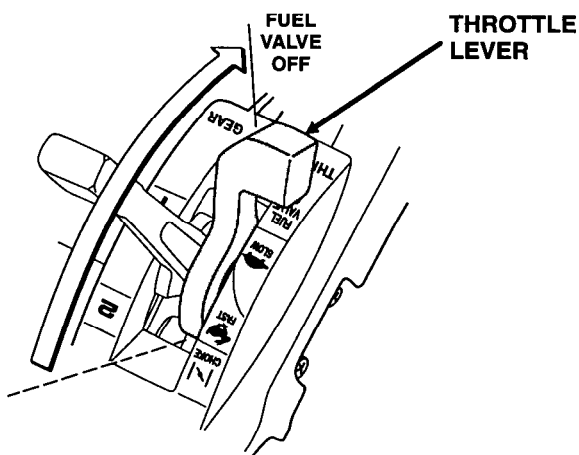

VE2CATAA.CDR

SAFE MOWING PRACTICES

For your safety, keep all four wheels on the ground, and be careful to avoid losing your footing and your control of the mower. Keep a firm grip on the handlebar, and walk, never run, with the mower. Be very careful when mowing uneven or rough ground.

If stuck, do not kick or shove the mower with your foot. Use the handlebar to control the mower.

⚠ WARNING

The blade is sharp and spins at high speed.

A spinning blade can cut you severely and can amputate fingers and toes.

- Wear protective footwear.
- Keep your hands and feet away from the mower deck while the engine is running.
- Stop the engine before performing any adjustment, inspection, or maintenance.

Slopes

Mow across slopes, not up and down. Avoid steep slopes (more than 20°), and be careful when changing direction.

Mowing on a slope when the grass is damp or wet could cause you to slip, fall, and lose control of the mower.

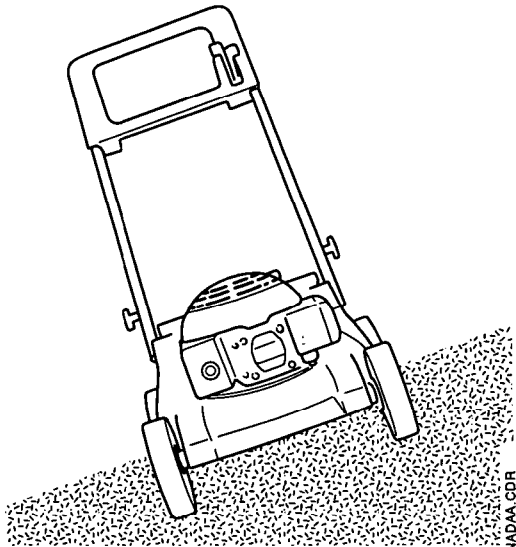

OPERATION

Obstacles

Use the side of the mower to cut close to large obstacles, such as fences or walls.

Release the drive clutch lever to disengage the drive when mowing around trees and other obstacles. Push the mower around obstacles for better directional control. Be careful when mowing over obstacles embedded in the lawn, such as sprinkler heads, paving, edging, etc. Avoid anything that sticks up above the surface of the lawn.

If the blade(s) hits something, or if the mower starts to vibrate, stop the engine immediately and check for damage. Striking objects may damage the blade(s), bend the crankshaft, and/or break the mower deck or other components. Vibration usually indicates serious trouble.

WARNING

A worn, cracked, or damaged blade can break, and pieces of the damaged blade can become dangerous projectiles.

Thrown objects can cause serious injury.

Inspect the blade regularly, and do not operate the mower with a worn or damaged blade.

The Distributor's Limited Warranty does not cover parts damaged by accident or collision.

Gravel and Loose Objects

Gravel, loose stones, and landscaping material can be picked up by the mower and thrown many feet with enough force to cause serious personal injury and/or property damage. The best way to prevent potential injury from thrown objects is to release the flywheel brake lever to stop the blade(s) before reaching areas with gravel, loose stones, or landscaping material.

MOWING TIPS

When to Mow

Most grasses should be mowed when they have grown $\frac{1}{2}$ to 1 inch above their recommended height.

More frequent mowing is required for mulching than for bagging. For best results, you may need to mow the lawn twice a week during the growing season.

Cutting Height

Consult a local nursery or lawn and garden center for cutting height recommendations and advice about specific types of grasses and growing conditions in your area.

If you look closely, you'll see that most grass has stems and leaves. If you cut off the leaves, you'll scalp the lawn. Let the grass recover between mowings. Your mower will work better, and your lawn will look better.

If your grass gets too tall, cut it once at the highest cutting height setting, then mow again in 2 or 3 days. Don't take off more than one third of total grass height in any one mowing, or brown patches may develop.

Cutting height adjustment is explained on page 14.

Cutting Width

For an even lawn finish, overlap each mowing swath by a few inches. If the grass is very tall or thick, use more overlap and a narrower mowing swath.

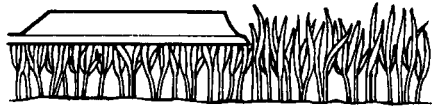

LM-AAEAA.TIF



LONG ENOUGH

LM-AAFAA.TIF



TOO SHORT

LM-AAGAA.TIF

OPERATION

Blade Speed

The blade(s) must spin very fast to cut properly. Always use the FAST throttle setting, and keep the engine running at maximum rpm.

If engine speed drops, it could mean the engine is being overloaded by the blade(s) trying to cut too much grass. Mow a narrower swath, move the mower slower, or raise the cutting height.

Blade Sharpness

A sharp blade cuts cleanly. A dull blade tears the grass, leaving shredded ends that turn brown. When your blade doesn't cut cleanly anymore, have it sharpened or replaced.

Dry Grass

If the ground is too dry, mowing will stir up a lot of dust. Besides being unpleasant to work in, too much dust will clog the carburetor air filter.

If dust is a problem, water your lawn the day before mowing. Mow when the grass is dry to your touch, but the soil is still moist.

Wet Grass

Wet grass is slippery and can make you lose your footing. Also, wet grass clippings will clog the mower deck and collect in clumps on the lawn. Always wait for wet grass to dry before mowing.

Fallen Leaves

When equipped with a grass bag, your mower can be used to pick up fallen leaves for disposal. If using the mower to bag large amounts of fallen leaves, and not for mowing, set the cutting height adjustment levers so the front of the mower deck is one or two settings higher than the rear.

If you want to mulch fallen leaves into your lawn, don't let the leaf cover get too deep before you begin. For best results, start mulching while grass still shows through the leaf cover. In places where fallen leaves completely cover the grass, remove the leaves by raking, or install a grass bag, so your mower can pick them up for disposal.

Clogged Mower Deck

Before clearing a clogged mower deck, stop the engine. Turn the fuel valve off by moving the throttle lever to the FUEL VALVE OFF position. With the spark plug cap disconnected, tilt the mower so the carburetor side is up.

Clear a clogged deck with a stick, not your hands.

Mowing Patterns

Your Honda mower will work most efficiently if you use the following mowing patterns as much as possible. Mower deck and equipment design, and the direction in which the blade rotates, cause these mowing patterns to give the best results.

Mulching

Use a counterclockwise mowing pattern. If the lawn has an irregular shape, or many obstacles, divide it into sections where you can use counterclockwise mowing patterns.

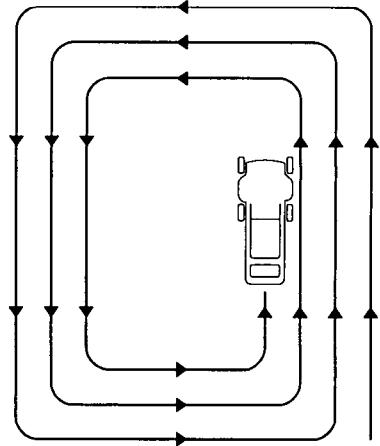

MULCHING PATTERN

LM-AAHAB.CDR

Bagging

Use a clockwise mowing pattern. This will give the best bagging performance, leaving the least amount of clippings on the lawn.

Side-Discharge Mowing

(requires optional side-discharge chute)

Use the clockwise mowing pattern, always discharging the clippings to the outside. This will prevent the clippings from building up in the path of the mower.

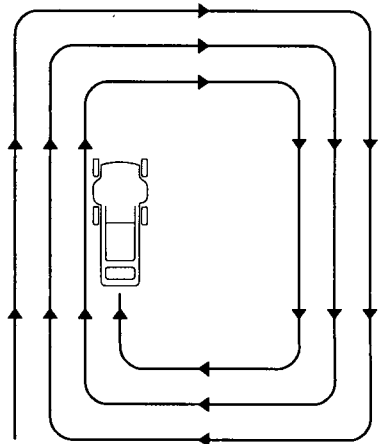

BAGGING & SIDE-DISCHARGE PATTERN

LM-AAHAA.CDR

TRANSPORTING

This chapter explains how to load and carry your mower safely.

| | |
|-----------------------------------|-----------|
| BEFORE LOADING | 38 |
| LOADING AND UNLOADING..... | 38 |

TRANSPORTING

BEFORE LOADING

If the engine has been running, allow it to cool for at least 15 minutes before loading the mower on the transport vehicle. A hot engine and exhaust system can burn you and can ignite some materials.

Remove the grass bag.

Put the throttle lever in the FUEL VALVE OFF position to shut off the fuel valve. This will prevent carburetor flooding and reduce the possibility of fuel leakage.

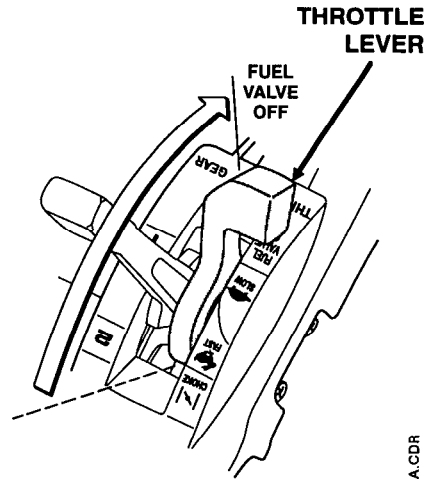

VE2CATAA.CDR

LOADING AND UNLOADING

If a suitable loading ramp is not available, two people should lift the mower on and off the transport vehicle while holding the mower level.

Position the mower so all four wheels are on the bed of the transport vehicle. Tie the mower down with rope or straps, and block the wheels. Keep the tie-down rope or straps away from the controls, adjustment levers, cables, and the carburetor.

The handlebar can be folded so the mower will take up less space (see page 69).

MAINTENANCE

This chapter explains when and how to perform routine inspection, service, and adjustments for do-it-yourself maintenance. More difficult maintenance tasks should be done by your dealer. Your dealer is best equipped and staffed to provide the level of service and safety you and your mower deserve.

| | |
|---|-----------|
| THE IMPORTANCE OF MAINTENANCE | 40 |
| MAINTENANCE SAFETY | 41 |
| Safety Precautions..... | 41 |
| EMISSION CONTROL SYSTEM | 42 |
| Source of Emissions..... | 42 |
| The California Clean Air Act..... | 42 |
| Tampering and Alteration..... | 42 |
| Problems that may Affect Emissions..... | 42 |
| PROPER MAINTENANCE IS OWNER'S RESPONSIBILITY | 43 |
| Replacement Parts..... | 43 |
| Maintenance..... | 43 |
| MAINTENANCE SCHEDULE | 44 |
| ENGINE MAINTENANCE | 45 |
| Engine Oil Change..... | 45 |
| Air Cleaner Service..... | 47 |
| Spark Plug Service..... | 48 |
| Carburetor Adjustment..... | 50 |
| Carburetor Modification for High Altitude Operation.... | 50 |
| Fuel Recommendations..... | 51 |
| CONTROL CABLE ADJUSTMENTS | 52 |
| Flywheel Brake Cable Adjustment..... | 52 |
| Drive Clutch Cable Adjustment (SDA)..... | 53 |
| Shift Cable Adjustment (SDA)..... | 54 |
| THROTTLE CABLE INSPECTION | 55 |
| BLADE REMOVAL AND INSTALLATION | 56 |
| Blade Removal..... | 56 |
| Blade Installation..... | 57 |
| GRASS BAG CLEANING AND REPLACEMENT (HRB215) | 58 |
| Grass Bag Cleaning..... | 58 |
| Grass Bag Replacement..... | 58 |

MAINTENANCE

THE IMPORTANCE OF MAINTENANCE

Good maintenance is essential for safe, economical, and trouble-free operation. It will also help reduce air pollution.

To help you properly care for your mower, the following pages include a maintenance schedule, routine inspection procedures, and simple maintenance procedures using basic hand tools. Other service tasks that are more difficult, or require special tools, are best handled by professionals and are normally performed by a Honda technician or other qualified mechanic.

The maintenance schedule applies to normal operating conditions. If you operate your mower under unusual conditions, consult an authorized Honda servicing dealer for recommendations applicable to your individual needs and use.

WARNING

Improper maintenance, or failure to correct a problem before operation, can cause a malfunction in which you can be seriously hurt or killed.

Always follow the inspection and maintenance recommendations and schedules in this owner's manual.

MAINTENANCE SAFETY

Some of the most important safety precautions follow. However, we cannot warn you of every conceivable hazard that can arise in performing maintenance. Only you can decide whether or not you should perform a given task.

WARNING

Failure to properly follow maintenance instructions and precautions can cause you to be seriously hurt or killed.

Always follow the procedures and precautions in this owner's manual.

Safety Precautions

- **Make sure the engine is off before you begin any maintenance or repairs.** This will eliminate several potential hazards:
 - **Carbon monoxide poisoning from engine exhaust.**
Be sure there is adequate ventilation whenever you operate the engine.
 - **Burns from hot parts.**
Let the engine and exhaust system cool before touching.
 - **Injury from moving parts.**
Do not run the engine unless instructed to do so.
- Read the instructions before you begin, and make sure you have the tools and skills required.
- To reduce the possibility of fire or explosion, be careful when working around gasoline. Use only a nonflammable solvent, not gasoline, to clean parts. Keep cigarettes, sparks, and flames away from all fuel-related parts.

Remember that an authorized Honda servicing dealer knows your mower best and is fully equipped to maintain and repair it.

To ensure the best quality and reliability, use only new, genuine Honda parts or their equivalents for repair and replacement.

MAINTENANCE

EMISSION CONTROL SYSTEM

Source of Emissions

The combustion process produces carbon monoxide, oxides of nitrogen, and hydrocarbons. Control of hydrocarbons and oxides of nitrogen is very important because, under certain conditions, they react to form photochemical smog when subjected to sunlight. Carbon monoxide does not react in the same way, but it is toxic.

Honda utilizes lean carburetor settings and other systems to reduce the emissions of carbon monoxide, oxides of nitrogen, and hydrocarbons.

The California Clean Air Act

California regulations require all manufacturers to furnish written instructions describing the operation and maintenance of emission control systems.

The following instructions and procedures must be followed in order to keep the emissions from your Honda engine within the emission standards.

Tampering and Alteration

Tampering with or altering the emission control system may increase emissions beyond the legal limit. Among those acts that constitute tampering are:

- Removal or alteration of any part of the intake, fuel, or exhaust systems.
- Altering or defeating the governor linkage or speed-adjusting mechanism to cause the engine to operate outside its design parameters.

Problems that may Affect Emissions

If you are aware of any of the following symptoms, have your engine inspected and repaired by your dealer.

- Hard starting or stalling after starting.
- Rough idle.
- Misfiring or backfiring under load.
- Afterburning (backfiring).
- Black exhaust smoke or high fuel consumption.

PROPER MAINTENANCE IS THE OWNER'S RESPONSIBILITY

Replacement Parts

The emission control systems on your new Honda engine were designed, built, and certified to conform with the California regulations. Honda recommends only the use of new, genuine Honda parts or their equivalent. The use of other replacement parts which are not of equivalent quality may impair the effectiveness of your emission control system.

Maintenance

Follow the maintenance schedule on page 44. Remember that this schedule is based on the assumption that your machine will be used for its designed purpose. Sustained high-load or high-temperature operation, or use in unusually wet or dusty conditions, will require more frequent service.

MAINTENANCE

MAINTENANCE SCHEDULE

| ITEM | REGULAR SERVICE PERIOD (3) | | Before Each Use | First 20 Hours | Every 50 Hours | Every 100 Hours | Every 300 Hours | Refer to page | |
|------|--|----------------|-------------------|----------------|----------------|-----------------|-----------------|---------------|---|
| | Perform at every indicated interval | | | | | | | | |
| | Blade condition and blade bolt tightness | Check | O | | | | | 17 57 | |
| | Grass bag (HRB215) | Check | O | | | | | 22 | |
| • | Engine oil | Check | O | | | | | 18 | |
| | | Change | | O | | O | | 45 | |
| • | Air Cleaner | Check | O | | | | | 20 | |
| | | Clean-Replace* | | | O(1) | | | 47 | |
| • | Spark plug | Clean-Adjust | | | | O | | 48 | |
| | | Replace | | | | | O | | |
| | Spark arrester (optional equipment) | Clean | | | | O | | 79 | |
| • | Idle speed | Check-Adjust | | | | | O(2) | 50 | |
| | Flywheel brake cable | Adjust | | O | | O | | 52 | |
| | Flywheel brake pad | Check-Adjust | | O(2) | | O(2) | | - | |
| | Drive clutch (SDA) cable | Adjust | | O | | O | | 53 | |
| | Shift cable (SDA) | Adjust | | O | | O | | 54 | |
| | Throttle cable | Adjust | | O(2) | | O(2) | | - | |
| • | Valve clearance | Adjust | | | | | O(2) | - | |
| • | Fuel tank | Clean | | | | | O(2) | - | |
| • | Fuel line | Replace | Every 2 years (2) | | | | | | - |

- Emission related items.

* Replace the paper element only.

- (1) Service more frequently when used in dusty areas.
- (2) These items should be serviced by an authorized Honda servicing dealer, unless you have the proper tools and are mechanically proficient. Refer to the Honda shop manual for service procedures.
- (3) For commercial use, log hours of operation to determine proper maintenance intervals.

ENGINE MAINTENANCE

Engine Oil Change

Drain the used oil while the engine is warm. Warm oil drains quickly and completely.

1. Put the throttle lever in the FUEL VALVE OFF position to shut off the fuel valve. This will reduce the possibility of fuel leakage (see page 30).
2. Wipe the oil filler area clean, then remove the oil filler cap/dipstick.
3. Place a suitable container next to the mower to catch the used oil, then tilt the mower on its right side. The used oil will drain through the filler neck. Allow the oil to drain completely.

Please dispose of used motor oil and the containers in a manner that is compatible with the environment. We suggest you take it in a sealed container to your local recycling center or service station for reclamation. Do not throw it in the trash, pour it on the ground or down a drain.

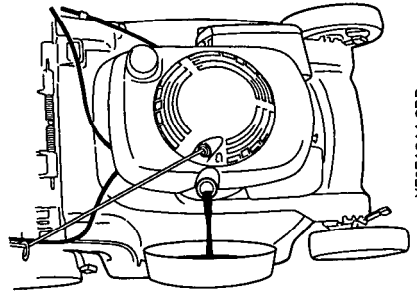

VEZEACAA.CDR

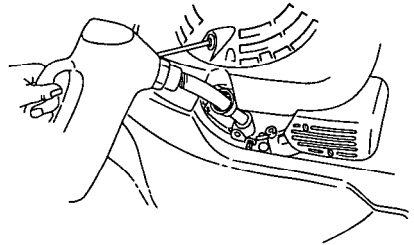

VEZEADAA.CDR

4. Fill with the recommended oil. Do not overfill; measure the oil level as shown on page 46.

Engine oil capacity:
0.6 l (0.63 US qt.).

NOTICE

Running the engine with a low oil level can cause engine damage.

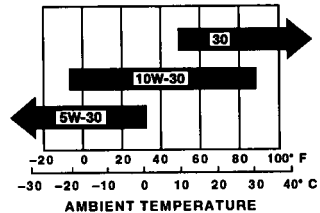

LW-AAJAA.CDR

Use 4-stroke motor oil that meets or exceeds the requirements for API service classification SF, SG, or equivalent. Always check the API SERVICE label on the oil container to be sure it includes the letters SF, SG, or equivalent.

MAINTENANCE

NOTICE

Using nondetergent oil can shorten the engine's service life, and using 2-stroke oil can damage the engine.

SAE 10W-30 is recommended for general use. Other viscosities shown in the chart (previous page) may be used when the average temperature in your area is within the indicated range.

5. After changing the engine oil, and before starting the engine, check the oil level with the mower on a level surface:
 - a. Wipe the dipstick clean.
 - b. Insert and remove the dipstick without screwing it into the filler neck. Check the oil level shown on the dipstick.
 - c. If the oil level is low, add oil to reach the upper limit mark on the dipstick. Do not overfill. If the engine is overfilled, the excess oil may get transferred to the air cleaner housing and air cleaner elements.

NOTICE

Running the engine with a low oil level can cause engine damage.

- d. Screw in the filler cap/dipstick securely.

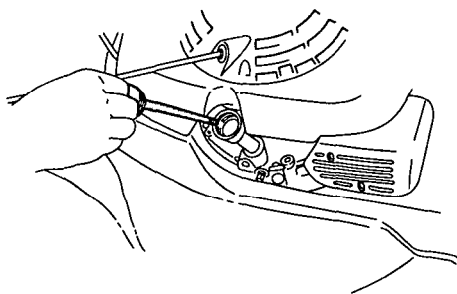

VE2EAAA.CDR

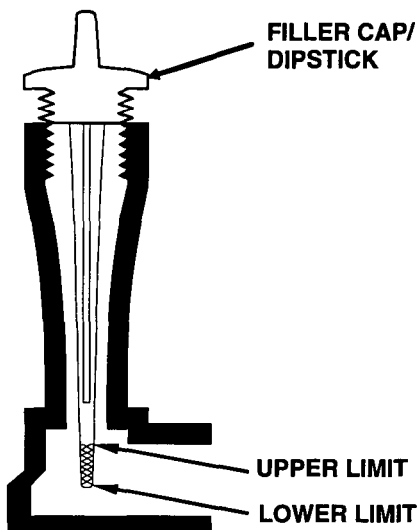

LM-A0AA.CDR

Air Cleaner Service

Dirty air filters will restrict air flow to the carburetor, reducing engine performance. If you operate the mower in very dusty areas, clean the air filters more often than specified in the MAINTENANCE SCHEDULE.

NOTICE

Operating the engine without air filters, or damaged filters, will allow dirt to enter the engine, causing rapid engine wear. This type of damage is not covered by the Distributor's Limited Warranty.

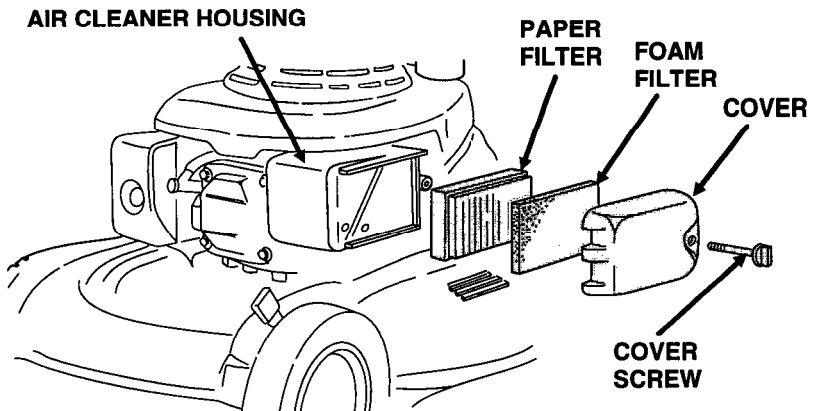

VEZFABAA.CDR

1. Unscrew and remove the air cleaner cover screw, then remove the air cleaner cover.
2. Remove the paper filter from the air cleaner housing. Remove the foam filter from the cover.
3. Inspect the filters, and replace them if they are damaged.
4. Clean the filters.

Paper filter: Tap the filter several times on a hard surface to remove dirt, or blow compressed air [not exceeding 207 kPa (30 psi)] through the filter from the inside. Never try to brush off dirt; brushing will force dirt into the fibers.

Foam filter: Clean in warm soapy water, rinse, and allow to dry thoroughly. Or clean in nonflammable solvent and allow to dry.

MAINTENANCE

5. Wipe dirt from the inside of the air cleaner housing and cover, using a moist rag. Be careful to prevent dirt from entering the air duct that leads to the carburetor.
6. Reinstall the filters and cover. Tighten the cover screw securely.

Spark Plug Service

| Recommended Spark Plugs | Regular | Resistor* |
|-------------------------|---------|-----------|
| NGK | BP5ES | BPR5ES |
| ND | W16WP-U | W16EPR-U |
| CHAMPION | N12Y | RN12Y |

* Resistor spark plugs reduce interference with radio and TV reception.

NOTICE

Incorrect spark plugs can cause engine damage.

For good performance, the spark plug must be properly gapped and free of deposits.

1. Disconnect the spark plug cap and remove any dirt from around the spark plug area.

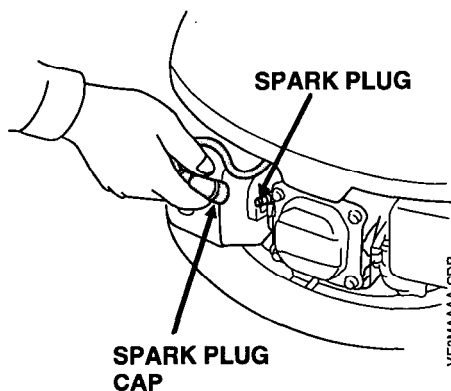

VEZMAAAA.CDR

2. Remove the spark plug with a 21 mm ($\frac{13}{16}$ in) spark plug wrench.
3. Inspect the spark plug. Replace it if the electrodes are worn, or if the insulator is cracked or chipped. Clean the spark plug with a wire brush if you are going to reuse it.
4. Measure the spark plug electrode gap with a suitable gauge. The gap should be 0.7 ~ 0.8 mm (0.028 ~ 0.031 in). Correct the gap, if necessary, by carefully bending the side electrode.
5. Install the spark plug carefully, by hand, to avoid cross-threading.
6. After the spark plug seats, tighten with a 21 mm ($\frac{13}{16}$ in) spark plug wrench to compress the washer.

If reinstalling the old spark plug, tighten $\frac{1}{8}$ to $\frac{1}{4}$ turn after the spark plug seats.

If installing a new spark plug, tighten $\frac{1}{2}$ turn after the spark plug seats to compress the washer.

NOTICE

A loose spark plug can overheat and damage the engine. Overtightening the spark plug can damage the threads in the cylinder head.

7. Install the spark plug cap on the spark plug.

SPARK PLUG WRENCH

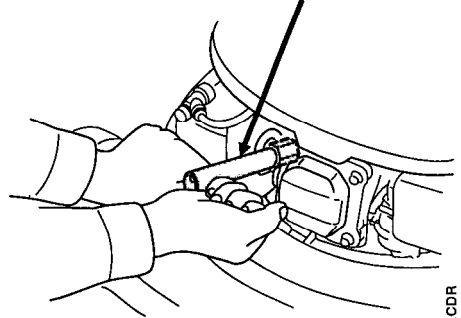

VE2MABAA.CDR

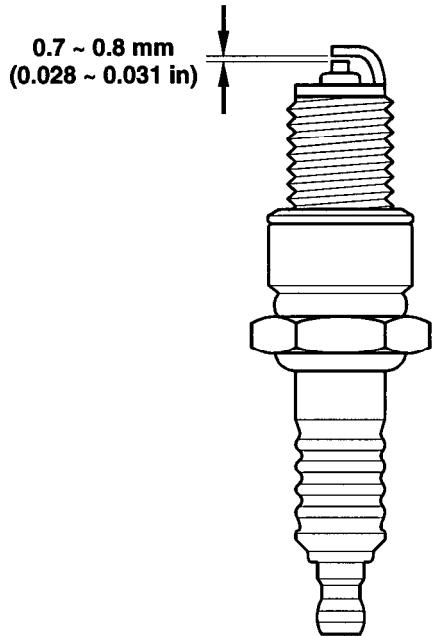

LM-AAKAA.CDR

MAINTENANCE

Carburetor Adjustment

1. Start the engine outdoors, and allow it to warm up to normal operating temperature.
2. Set the throttle lever in the SLOW position.
3. Turn the throttle stop screw to obtain the standard idle speed.

Standard idle speed:
2,100 \pm 150 rpm

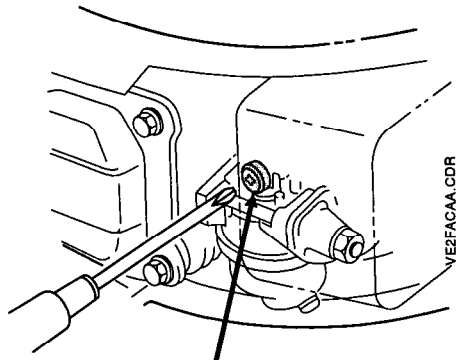

THROTTLE STOP SCREW

Carburetor Modification for High Altitude Operation

At high altitude, the standard carburetor air-fuel mixture will be too rich. Performance will decrease, and fuel consumption will increase. A very rich mixture will also foul the spark plug and cause hard starting.

High altitude performance can be improved by specific modifications to the carburetor. If you always operate your mower at altitudes above 1,800 meters (6,000 feet) have an authorized Honda servicing dealer perform this carburetor modification.

Even with carburetor modification, engine horsepower will decrease about 3.5% for each 300 meter (1,000 foot) increase in altitude. The effect of altitude on horsepower will be greater than this if no carburetor modification is made.

NOTICE

When the carburetor has been modified for high altitude operation, the air-fuel mixture will be too lean for low altitude use. Operation at altitudes below 1,800 meters (6,000 feet) with a modified carburetor may cause the engine to overheat and result in serious engine damage. For use at low altitudes, have an authorized Honda servicing dealer return the carburetor to original factory specifications.

Fuel Recommendations

Use unleaded gasoline with a pump octane rating of 86 or higher.

This engine is certified to operate on unleaded gasoline. Unleaded gasoline produces fewer engine and spark plug deposits and extends exhaust system life.

Never use stale or contaminated gasoline or an oil/gasoline mixture. Avoid getting dirt or water in the fuel tank.

Occasionally you may hear light "spark knock" or "pinging" (metallic rapping noise) while operating under heavy loads. This is no cause for concern.

If spark knock or pinging occurs at a steady engine speed, under normal load, change brands of gasoline. If spark knock or pinging persists, see an authorized Honda servicing dealer.

| |
|---------------|
| NOTICE |
|---------------|

Running the engine with persistent spark knock or pinging can cause engine damage.

Running the engine with persistent spark knock or pinging is misuse, and the Distributor's Limited Warranty does not cover parts damaged by misuse.

For oxygenated fuel information refer to page 78.

MAINTENANCE

CONTROL CABLE ADJUSTMENTS

Flywheel Brake Cable Adjustment

Measure free play at the top of the lever. Free play should be 5~15 mm ($\frac{3}{16}$ ~ $\frac{9}{16}$ in). If adjustment is necessary:

1. Loosen the locknuts with a 10 mm wrench, and move the adjuster up or down as required.
2. Tighten the locknuts and recheck free play.
3. Start the engine outdoors. Move the throttle to FAST. Release the flywheel brake lever; the engine should stop quickly. If the flywheel brake does not operate properly with the correct cable adjustment, take the mower to a an authorized Honda servicing dealer for repair.

5 ~ 15 mm
($\frac{3}{16}$ ~ $\frac{9}{16}$ in)

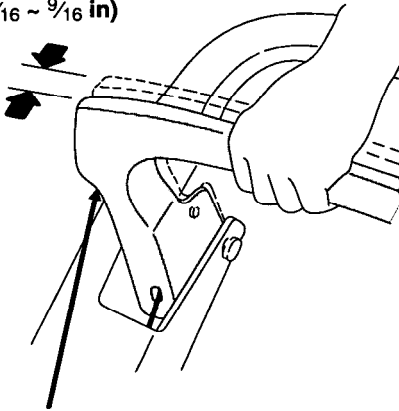

FLYWHEEL BRAKE LEVER

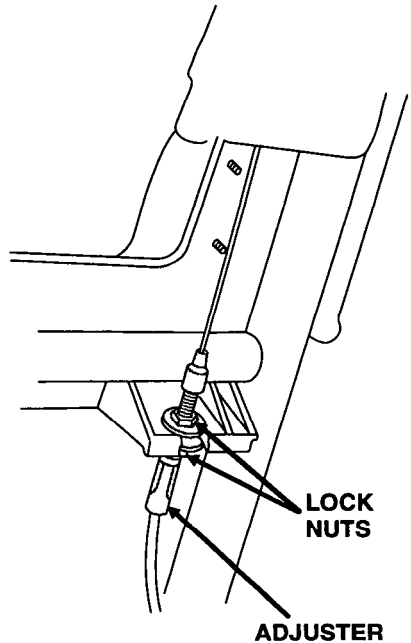

VE2CAVAA.CDR

VE2CAJAA.CDR

Drive Clutch Cable Adjustment (SDA)

Measure free play at the top of the lever, as shown. Free play should be 1 ~ 4 mm ($\frac{1}{16}$ ~ $\frac{3}{16}$ in). If adjustment is necessary:

1. Loosen the lock nuts with a 10 mm wrench, and move the adjuster up or down as required.
2. Tighten the lock nuts and recheck free play.
3. Start the engine outdoors, and operate the drive clutch lever. Check that the drive clutch engages and releases properly.

If the drive clutch does not operate as it should, with correct cable adjustment, take the mower to an authorized Honda servicing dealer for repair.

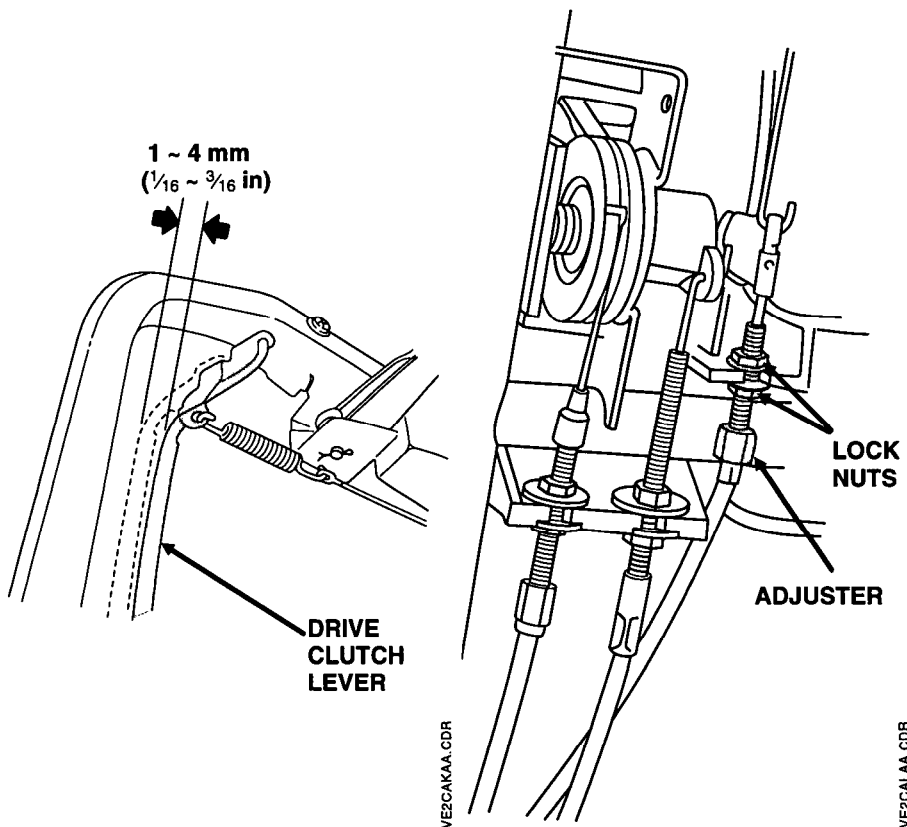

MAINTENANCE

Shift Cable Adjustment (SDA)

Shift cable adjustment is necessary if the shift lever does not operate smoothly or does not shift properly into a gear.

With the transmission in 1st gear, pull the shift lever all the way back and release it; the lever should be approximately centered on the number "1" on the lever cover. If adjustment is necessary:

1. Loosen the lock nuts with a 10 mm wrench, and move the adjuster up or down as required.
2. Tighten the lock nuts and recheck lever alignment.
3. Start the engine outdoors, and operate the shift lever (release the drive clutch lever before moving the shift lever). Check that the transmission shifts properly, and that the lever is approximately aligned with the numbers beside it.

If the transmission does not shift as it should with correct cable adjustment, take the mower to an authorized Honda servicing dealer for repair.

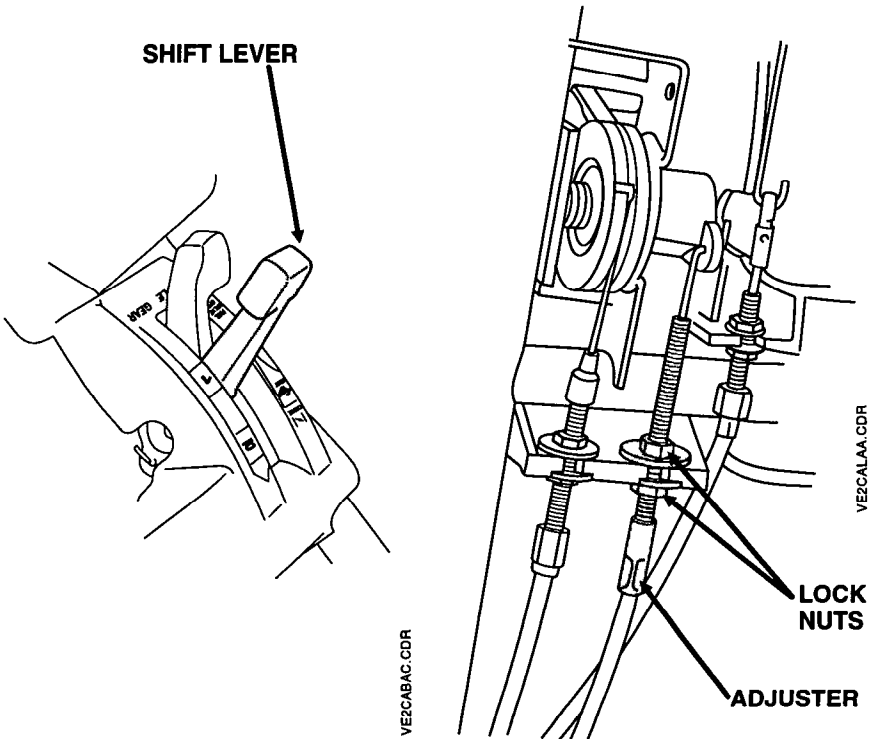

THROTTLE CABLE INSPECTION

Throttle cable adjustment is necessary if the throttle lever does not operate the choke properly.

You can inspect choke operation by observing the movement of the choke arm, which is located on top of the carburetor.

1. Move the throttle lever to the **CHOKE** position. The choke arm should move counterclockwise, until it contacts the stop post on the carburetor.

Push the choke arm with your finger to verify that it has moved as far as it will go.

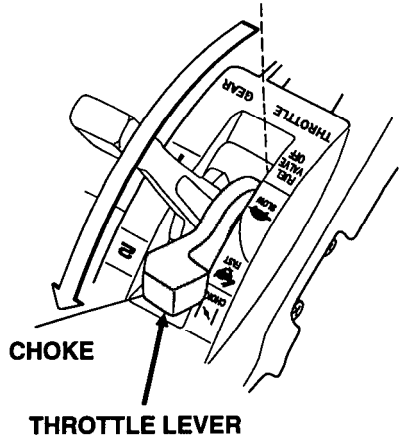

VE2CA0AA.CDR

2. Move the throttle lever to the **FAST** position. The choke arm should move clockwise, until it contacts the stop post on the carburetor.

Push the choke arm with your finger to verify that it has moved as far as it will go.

3. If the choke arm does not move all the way to its stop, in either direction, take the mower to an authorized Honda servicing dealer. Throttle cable adjustment involves related control plate adjustments.

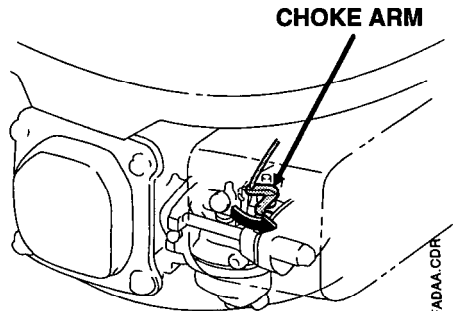

VE2FADA.A.CDR

MAINTENANCE

BLADE REMOVAL AND INSTALLATION

If you remove the blade(s) for sharpening or replacement, you will need a torque wrench for installation. Wear heavy gloves to protect your hands.

BLADE SHARPENING: To avoid weakening the blade(s), or causing imbalance or poor cutting, the blade(s) should be sharpened by trained staff at an authorized Honda servicing dealer.

BLADE REPLACEMENT: Use genuine Honda replacement blades or their equivalent.

Blade Removal

1. Put the throttle lever in the FUEL VALVE OFF position to close the fuel valve. Disconnect the spark plug cap, then tilt the mower to the right side, so the carburetor side is up. This will help to prevent fuel leakage and hard starting due to carburetor flooding.
2. Remove the two blade bolts with a 14 mm socket wrench. Use a wooden block to prevent the blade(s) from turning when removing the bolts.
3. Remove the blade(s) from the blade holder.

UPPER MULCHING BLADE
(standard for HRM215)

BLADE BOLT (2)

SPECIAL WASHER (2)

LOWER MULCHING BLADE
(standard for HRM215)
or
HIGH-LIFT BLADE
(standard for HRB215)

Blade Installation

1. Clean dirt and grass from around the blade mounting area.
2. Install the blade(s) using the two blade bolts and special washers as shown.

Be sure to install the special washers with the concave side toward the blade(s) and the convex side (marked **OUT**) toward the bolt heads.

The blade bolts are specially designed for this application and must not be replaced with other bolts.

3. Tighten the blade bolts with a torque wrench. Use a wooden block to prevent the blade(s) from turning when tightening the bolts.

Blade bolt torque: 49 ~ 59 N·m (5.0 ~ 6.0 kg-m, 36 ~ 43 ft-lb)

If you do not have a torque wrench, have an authorized Honda servicing dealer tighten the blade bolts before you use the mower. If the blade bolts are overtightened, they could break. If the blade bolts are not tightened enough, they could loosen or come out. In either case, it would be possible for the blade(s) to fly off while you are operating the mower.

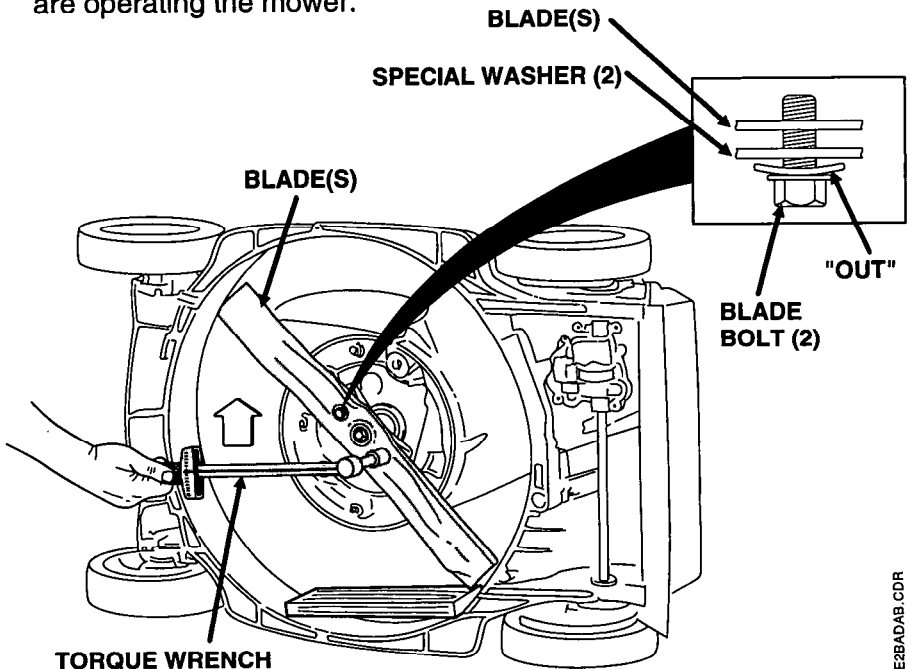

MAINTENANCE

GRASS BAG CLEANING AND REPLACEMENT (HRB215)

Grass Bag Cleaning

Wash the bag with a garden hose, and allow it to dry completely before use; a wet bag will clog quickly.

Grass Bag Replacement

Replace a worn or damaged bag with a Honda replacement bag or its equivalent.

Bag Removal

1. Unclip the plastic edges of the bag from the frame.
2. Remove the bag from the frame.

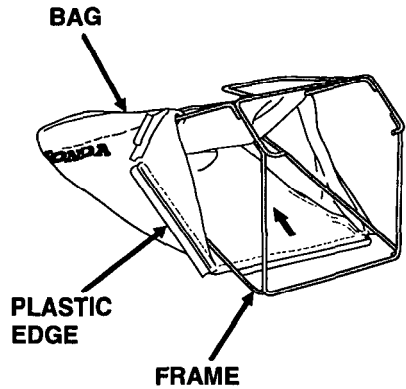

VE1GAAA.TIF

Bag Installation

1. Insert the bag frame into the bag, as shown.
2. Clip the plastic edges of the bag onto the frame, as shown.

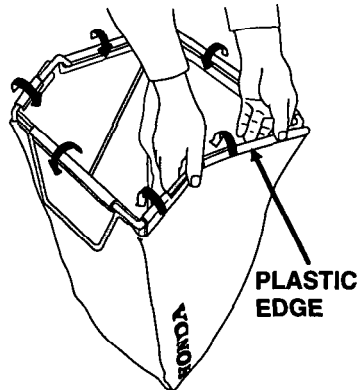

VE1GABAA.CDR

TROUBLESHOOTING

This chapter shows what to check if you have a problem with your mower.

| | |
|--|-----------|
| ENGINE PROBLEMS | 60 |
| Engine will not start | 60 |
| Loss of power | 60 |
| VIBRATION PROBLEMS | 61 |
| MOWING AND BAGGING PROBLEMS | 61 |

TROUBLESHOOTING

ENGINE PROBLEMS

| Engine Will Not Start | Possible Cause | Correction |
|---|--|--|
| 1. Check throttle lever position. | Throttle lever in wrong position. | Move throttle lever to CHOKE position, unless the engine is warm (p. 26). |
| 2. Check fuel. | Out of fuel. Bad fuel; mower stored without treating or draining gasoline, or refueled with bad gasoline. | Refuel (p. 19). Drain fuel tank and carburetor (p. 67). Refuel with fresh gasoline (p. 19). |
| 3. Remove and inspect spark plug. | Spark plug faulty, fouled, or improperly gapped. Spark plug wet with fuel (flooded engine). | Clean, gap, or replace spark plug (p. 49). Dry and reinstall spark plug. Start engine with throttle lever in FAST position. |
| 4. Take mower to an authorized Honda servicing dealer, or refer to shop manual. | Fuel filter clogged, carburetor malfunction, ignition malfunction, valves stuck, etc. | Replace or repair faulty components as necessary. |

| Loss of Power | Possible Cause | Correction |
|---|--|---|
| 1. Check throttle position. | Throttle not set to FAST. | Move throttle to FAST (p. 28). |
| 2. Check grass height. | Grass too tall to cut. | Raise cutting height (p. 14), cut narrower swath (p. 33), or cut more frequently. |
| 3. Check under mower deck. | Mower deck clogged. | Clean out mower deck (p. 34). |
| 4. Check air filters. | Air filters clogged. | Clean or replace air filters (p. 47). |
| 5. Check fuel. | Bad fuel; mower stored without treating or draining gasoline, or refueled with bad gasoline. | Drain fuel tank and carburetor (p. 67). Refuel with fresh gasoline (p. 19). |
| 6. Take mower to an authorized Honda servicing dealer, or refer to shop manual. | Fuel filter clogged, carburetor malfunction, ignition malfunction, valves stuck, etc. | Replace or repair faulty components as necessary. |

VIBRATION PROBLEMS

| Excessive Vibration | Possible Cause | Correction |
|---|--|---|
| 1. Check mower deck and blade(s). | Grass and debris lodged under mower deck. | Clean out mower deck (p.34). |
| | Blade(s) loose, bent, damaged, or unbalanced by improper sharpening. | Tighten loose blade bolts. Replace damaged blade(s) (p. 56 - 57). |
| 2. Take mower to an authorized Honda servicing dealer for repair. | Mechanical damage, such as a bent crankshaft. | Replace or repair faulty components as necessary. |

MOWING AND BAGGING PROBLEMS

| Poor Cut Quality or Poor Mowing/Bagging Performance | Possible Cause | Correction |
|---|---|---|
| 1. Check that the throttle lever is in the FAST position. | Engine speed is too slow to cut well. | Move throttle lever to the FAST position (p. 28). |
| 2. Reduce forward speed. | Mower is moving too fast for lawn conditions. | Shift to slow speed (p. 29), or push slower. |
| 3. Check cutting height adjustment levers. | Adjustment levers set at different positions. | Set all levers at the same cutting height position (p. 14). |
| 4. Check grass bag (if equipped). | Grass bag overfilled or clogged. | Empty the grass bag. Wash the grass bag if clogged with dirt (p. 58). |
| 5. Check mower deck and blade. | Mower deck clogged. | Clean out the mower deck (p. 34). |
| | Blade(s) dull, worn, or damaged. | Sharpen or replace blade(s) if necessary (p. 56 - 57). |
| | Wrong blade(s) installed. | Install correct blades (p. 56 - 57). |

STORAGE

This chapter explains how to protect your mower from rust and corrosion, and ensure that it will start easily when you want to use it again.

| | |
|--|-----------|
| STORAGE PREPARATION | 64 |
| Cleaning | 64 |
| Engine | 64 |
| Mower Deck | 64 |
| Grass Bag (HRB215) | 64 |
| Fuel | 66 |
| Adding fuel stabilizer to extend fuel storage life | 66 |
| Draining the Fuel Tank and Carburetor | 67 |
| Engine Oil | 67 |
| Engine Cylinder | 68 |
| Handlebar Folding | 69 |
| PLACING IN STORAGE | 70 |
| REMOVING FROM STORAGE | 70 |

STORAGE

STORAGE PREPARATION

Proper storage preparation is essential for keeping your lawn mower troublefree and looking good. The following steps will help to keep rust and corrosion from impairing your lawn mower's function and appearance, and will make the engine easier to start when you use the lawn mower again.

Cleaning

1. Wash the lawn mower, including the underside of the mower deck.

Engine

Wash the engine by hand, and be careful to prevent water from entering the air cleaner.

NOTICE

- Using a garden hose or pressure washing equipment can force water into the air cleaner. Water in the air cleaner will soak the filters and can enter the carburetor or engine cylinder, causing damage.
- Water contacting a hot engine can cause damage. If the engine has been running, allow it to cool for at least half an hour before washing.

Mower Deck

If using a garden hose or pressure washing equipment to clean the mower deck, be careful to avoid getting water into controls and cables, or anywhere near the engine air cleaner or muffler opening.

Before washing the underside of the mower deck, be sure the throttle lever is in the FUEL VALVE OFF position. Rest the mower on its right side, so the carburetor side is up. This will help to prevent fuel leakage and hard starting due to carburetor flooding. Wear heavy gloves to protect your hands from the blade(s).

Grass Bag (HRB215)

Remove the bag from the mower, and wash it with a garden hose or pressure washing equipment. Allow the bag to dry completely before storage.

2. After washing the lawn mower, wipe dry all accessible surfaces.

3. With the mower in an upright position, start the engine outdoors, and let it run until it reaches normal operating temperature to evaporate any water remaining on the engine.
4. Stop the engine and allow it to cool.
5. After the lawn mower is clean and dry, touch up any damaged paint, and coat other areas that may rust with a light film of oil. Lubricate the control cable cores with a silicone spray lubricant.

STORAGE

Fuel

Gasoline will oxidize and deteriorate in storage. Old gasoline will cause hard starting, and it leaves gum deposits that clog the fuel system. If the gasoline in your mower deteriorates during storage, you may need to have the carburetor and other fuel system components, serviced or replaced.

The length of time that gasoline can be left in your fuel tank and carburetor without causing functional problems will vary with such factors as gasoline blend, your storage temperatures, and whether the fuel tank is partially or completely filled. The air in a partially filled fuel tank promotes fuel deterioration. Very warm storage temperatures accelerate fuel deterioration. Fuel deterioration problems may occur within a few months, or even less if the gasoline was not fresh when you filled the fuel tank.

The Distributor's Limited Warranty does not cover fuel system damage or engine performance problems resulting from neglected storage preparation.

You can extend fuel storage life by adding a gasoline stabilizer that is formulated for that purpose, or you can avoid fuel deterioration problems by draining the fuel tank and carburetor.

Adding fuel stabilizer to extend fuel storage life:

When adding a fuel stabilizer, fill the fuel tank with fresh gasoline. If only partially filled, air in the tank will promote fuel deterioration during storage. If you keep a container of gasoline for refueling, be sure that it contains only fresh gasoline.

1. Add fuel stabilizer following the manufacturer's instructions.
2. After adding a fuel stabilizer, run the engine outdoors for 10 minutes to be sure that treated gasoline has replaced the untreated gasoline in the carburetor.
3. Stop the engine, and move the throttle lever to the FUEL VALVE OFF position. This turns off the fuel valve between the fuel tank and the carburetor.

Draining the Fuel Tank and Carburetor:

1. Remove the carburetor drain bolt with a 10 mm wrench, and drain the carburetor bowl fuel into an approved container.

⚠ WARNING

Gasoline is highly flammable and explosive and you can be burned or seriously injured when handling fuel.

- Stop engine and keep heat, sparks, and flame away.
- Refuel only outdoors.
- Wipe up spills immediately.

2. Move the throttle lever to the SLOW or FAST position to open the fuel valve. This will allow fuel in the fuel tank to drain through the carburetor bowl.

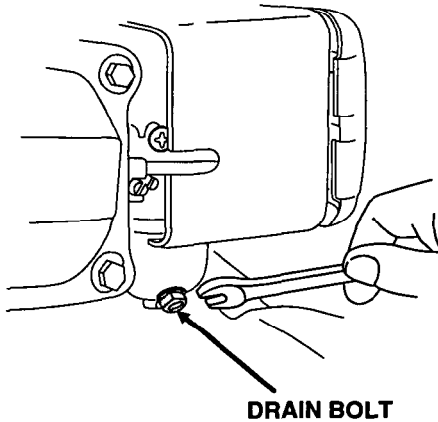

3. Reinstall the drain bolt.

Engine Oil

Change the engine oil (see page 45).

STORAGE

Engine Cylinder

Remove the spark plug (see page 49). Pour a tablespoon (5 ~ 10 cc) of clean engine oil into the cylinder. Pull the starter rope several times to distribute the oil in the cylinder. Reinstall the spark plug.

Pull the starter rope slowly until resistance is felt then return the starter grip gently. This will close the valves so moisture cannot enter the engine cylinder.

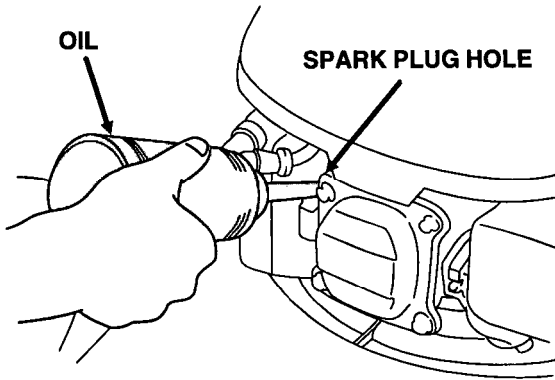

Handlebar Folding

The handlebar can be folded for storage or transport by loosening the handlebar locking knobs.

1. Remove the grass bag, if so equipped. You can place it on top of the engine, with the bag opening to the front.
2. Remove the starter rope from the lower guide on the handlepipe. This will prevent damage to the starter rope.
3. Loosen the handlebar locking knobs.
4. Spread the lower ends of the handlebar struts to release the locating pins.
5. Fold the handlebar forward, over the top of the mower. When folding the handlebar, be careful to avoid kinking or pinching the control cables.

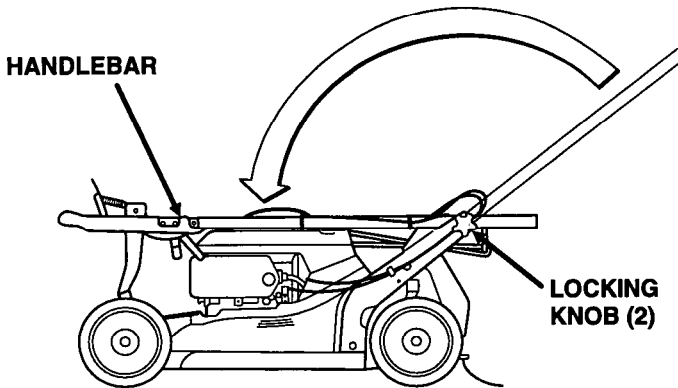

STORAGE

PLACING IN STORAGE

If your mower will be stored with gasoline in the fuel tank and carburetor, it is important to reduce the hazard of gasoline vapor ignition. Select a well-ventilated storage area away from any appliance that operates with a flame, such as a furnace, water heater, or clothes dryer. Also avoid any area with a spark-producing electric motor, or where power tools are operated.

If possible, avoid storage areas with high humidity, because that promotes rust and corrosion.

Unless all fuel has been drained from the fuel tank, leave the throttle lever in the FUEL VALVE OFF position to close the fuel valve and reduce the possibility of fuel leakage.

Place the mower with its wheels on a level surface. Tilting can cause fuel or oil leakage.

The handlebar can be folded for compact storage (see page 69).

With the engine and exhaust system cool, cover the mower to keep out dust. A hot engine and exhaust system can ignite or melt some materials. Do not use sheet plastic as a dust cover. A nonporous cover will trap moisture around the mower, promoting rust and corrosion.

REMOVING FROM STORAGE

Check your mower as described in the BEFORE OPERATION chapter of this manual.

If the fuel was drained during storage preparation, fill the tank with fresh gasoline. If you keep a container of gasoline for refueling, be sure that it contains only fresh gasoline. Gasoline oxidizes and deteriorates over time, causing hard starting.

If the cylinder was coated with oil during storage preparation, the engine will smoke briefly at startup. This is normal.

SPECIFICATIONS

This chapter gives dimensions, capacities, and other technical information.

| | |
|--|-----------|
| MOWER MODELS | 72 |
| DIMENSION, WEIGHTS, AND CAPACITIES..... | 72 |
| ENGINE DESIGN AND PERFORMANCE | 73 |
| TRANSMISSION DESIGN AND PERFORMANCE | 73 |
| MAINTENANCE | 74 |
| TUNEUP | 74 |

SPECIFICATIONS

MOWER MODELS

HRB215PDA: Manually propelled, high-lift blade and grass bag

HRB215SDA: Self-propelled, high-lift blade and grass bag

HRM215PDA: Manually propelled, mulching blades and mulching plug

HRM215SDA: Self-propelled, mulching blades and mulching plug

DIMENSIONS, WEIGHTS, AND CAPACITIES

| | |
|--|---|
| Maximum Length (handlebar extended) | Handlebar high: 1,505 mm (59¼ in) Handlebar mid: 1,580 mm (62¾ in) Handlebar low: 1,635 mm (64¾ in) |
| Minimum Length (handlebar folded) | 1062 mm (41 ¹³ / ₁₆ in) |
| Width at Mower Deck | 580 mm (22 ¹³ / ₁₆ in) |
| Overall height (with cutting height set at 64 mm (2½ in)) | Handlebar high: 1,040 mm (40 ¹⁵ / ₁₆ in) Handlebar mid: 985 mm (38 ¹³ / ₁₆ in) Handlebar low: 925 mm (36 ⁷ / ₁₆ in) Handlebar folded: 483 mm (19 in) |
| Dry weight | HRB215PDA & HRM215PDA: 40.0 kg (88.2 lb) HRB215SDA & HRM215SDA: 42.0 kg (92.6 lb) |
| Cutting Width | 530 mm (21 in) |
| Approximate Cutting Height (adjustable) | HRB215: 19 mm (¾ in), 25 mm (1 in), 38 mm (1½ in), 51 mm (2 in), 64 mm (2½ in), 77 mm (3 in) HRM215: 25 mm (1 in), 38 mm (1½ in), 51 mm (2 in), 64 mm (2½ in), 77 mm (3 in), 90 mm (3½ in) |
| Fuel Tank Capacity | 1.0 ℓ (0.26 US gal) |
| Engine Oil Capacity | 0.6 ℓ (0.63 US qt) |
| Grass Bag Capacity | 83 ℓ (2.4 bushels, 2.9 cu ft, 21.9 US gal) |

ENGINE DESIGN AND PERFORMANCE

| | |
|--------------------|--|
| Engine Model | GXV140K1 |
| Engine Type | 4-stroke, overhead-valve, single cylinder, forced air-cooled |
| Displacement | 135 cc (8.2 cu in) |
| Bore and Stroke | 64 x 42 mm (2.52 x 1.65 in) |
| Compression Ratio | 8:1 |
| Ignition System | CDI |
| Maximum Horsepower | 3.7 kW (5.0 bhp) at 3,600 rpm |
| Maximum Torque | 10.3 N·m (7.6 ft·lb) at 2,700 rpm |

TRANSMISSION DESIGN AND PERFORMANCE (SDA)

| | |
|--|--|
| Transmission Type | 2 speed, manual shift |
| Mower Ground Speed (with engine at 3,300 rpm) | 1 (SLOW): 3.2 km/h (2.0 mph) 2 (FAST): 5.0 km/h (3.1 mph) |

SPECIFICATIONS

MAINTENANCE

| | | |
|--------------------------|---|------------------|
| Fuel | Unleaded gasoline with a pump octane rating of 86 or higher | See page 51. |
| Engine Oil | SAE 10W-30, API SF, SG, or equivalent | See page 45. |
| Transmission Oil (SDA) | Grease (NLGI #2) | See shop manual. |
| Spark Plug Type | NGK – BP5ES or BPR5ES ND – W16EPR-U or W16EP-U CHAMPION – N12Y or RN12Y | See page 48. |
| Maximum Governed Speed | 3,150 ~ 3,300 rpm | See shop manual. |
| Flywheel Brake Cable | Adjust for 5~15 mm ($\frac{3}{16}$ ~ $\frac{9}{16}$ in) free play at flywheel brake lever. | See page 52. |
| Drive Clutch Cable (SDA) | Adjust for 1 ~ 4 mm ($\frac{1}{16}$ ~ $\frac{3}{16}$ in) free play at drive clutch lever. | See page 53. |
| Shift Cable (SDA) | Adjust for smooth operation. | See page 54. |
| Throttle Cable | Adjust for proper choke operation and maximum governed speed. | See shop manual. |
| Blade Bolt Torque | 49 ~ 59 N·m (5.0 ~ 6.0 kg·m, 36 ~ 43 ft·lb) | See page 57. |

TUNEUP

| | | |
|------------------------|---|------------------|
| Spark Plug Gap | 0.7 ~ 0.8 mm (0.028 ~ 0.031 in) | See page 49. |
| Idle Speed | 2,100 ± 150 rpm | See page 50. |
| Valve Clearance (cold) | Intake: 0.15 ± 0.02 mm Exhaust: 0.20 ± 0.02 mm | See shop manual. |
| Other Specifications | No other adjustments needed. | |

ADDITIONAL INFORMATION

This chapter contains additional information, Honda publications available to you, and tells you how to contact us if you have a question or a warranty repair problem.

| | |
|--|-----------|
| HONDA PUBLICATIONS | 76 |
| Shop Manual | 76 |
| Parts Catalog | 76 |
| CUSTOMER SERVICE INFORMATION | 77 |
| OXYGENATED FUELS | 78 |
| SPARK ARRESTER SERVICE (OPTIONAL EQUIPMENT) | 79 |

ADDITIONAL INFORMATION

HONDA PUBLICATIONS

These publications will give you additional information for maintaining and repairing your mower. You may order them from your Honda lawn mower dealer.

Shop Manual

This manual covers complete maintenance and overhaul procedures. It is intended to be used by a skilled technician.

Parts Catalog

This manual provides complete, illustrated parts lists.

CUSTOMER SERVICE INFORMATION

Honda Power Equipment dealership personnel are trained professionals. They should be able to answer any question you may have. If you encounter a problem that your dealer does not solve to your satisfaction, please discuss it with the dealership's management. The Service Manager or General Manager can help. Almost all problems are solved in this way.

If you are dissatisfied with the decision made by the dealership's management, contact the Honda Power Equipment Customer Service Office. You can write:

American Honda Motor Co., Inc.
Honda Power Equipment Division
Customer Service Office
4475 River Green Parkway
Duluth, GA 30136-2565

Or telephone: (404) 497-6400

When you write or call, please give us this information:

- Model and serial numbers (see page 11)
- Name of the dealer who sold the lawn mower to you
- Name and address of the dealer who services your lawn mower
- Date of purchase
- Your name, address, and telephone number
- A detailed description of the problem

Current customer service contact information:

United States, Puerto Rico, and U.S. Virgin Islands:

Honda Power Equipment dealership personnel are trained professionals. They should be able to answer any question you may have. If you encounter a problem that your dealer does not solve to your satisfaction, please discuss it with the dealership's management. The Service Manager or General Manager can help. Almost all problems are solved in this way.

If you are dissatisfied with the decision made by the dealership's management, contact the Honda Power Equipment Customer Relations Office. You can write:

American Honda Motor Co., Inc.
Power Equipment Division
Customer Relations Office
4900 Marconi Drive
Alpharetta, GA 30005-8847

Or telephone: (770) 497-6400 M-F, 8:30 am - 7:00 pm EST

When you write or call, please provide the following information:

- Model and serial numbers
- Name of the dealer who sold the Honda power equipment to you
- Name and address of the dealer who services your equipment
- Date of purchase
- Your name, address, and telephone number
- A detailed description of the problem

ADDITIONAL INFORMATION

OXYGENATED FUELS

Some conventional gasolines are being blended with alcohol or an ether compound. These gasolines are collectively referred to as oxygenated fuels. To meet clean air standards, some areas of the United States and Canada use oxygenated fuels to help reduce emissions.

If you use an oxygenated fuel, be sure it is unleaded and meets the minimum octane rating requirement.

Before using an oxygenated fuel, try to confirm the fuel's contents. Some states/provinces require this information to be posted on the pump.

The following are the EPA approved percentages of oxygenates:

ETHANOL — (ethyl or grain alcohol) 10% by volume
You may use gasoline containing up to 10% ethanol by volume. Gasoline containing ethanol may be marketed under the name "Gasohol".

MTBE — (Methyl Tertiary Butyl Ether) 15% by volume
You may use gasoline containing up to 15% MTBE by volume.

METHANOL — (methyl or wood alcohol) 5% by volume
You may use gasoline containing up to 5% methanol by volume, as long as it also contains cosolvents and corrosion inhibitors to protect the fuel system. Gasoline containing more than 5% methanol by volume may cause starting and/or performance problems. It may also damage metal, rubber, and plastic parts of your fuel system.

If you notice any undesirable operating symptoms, try another service station, or switch to another brand of gasoline.

Fuel system damage or performance problems resulting from the use of an oxygenated fuel containing more than the percentages of oxygenates mentioned above are not covered under warranty.

SPARK ARRESTER SERVICE (OPTIONAL EQUIPMENT)

Your lawn mower engine is not factory-equipped with a spark arrester. In some areas, it is illegal to operate an engine without a spark arrester. Check local laws and regulations. A spark arrester is available from an authorized Honda servicing dealer.

The spark arrester must be serviced every 100 hours to keep it functioning as designed.

1. Allow the engine to cool, then remove the two nuts from the muffler shield, using a 10 mm socket wrench.
2. Remove the muffler shield, identification plate, muffler, and gasket.
3. Remove the spark arrester from the muffler.
4. Check for carbon deposits on the spark arrester and the exhaust port. Brush carbon deposits away. Be careful to avoid damaging the spark arrester screen.
5. Install the spark arrester in the muffler.
6. Install the muffler components on the engine, and tighten the two nuts securely.

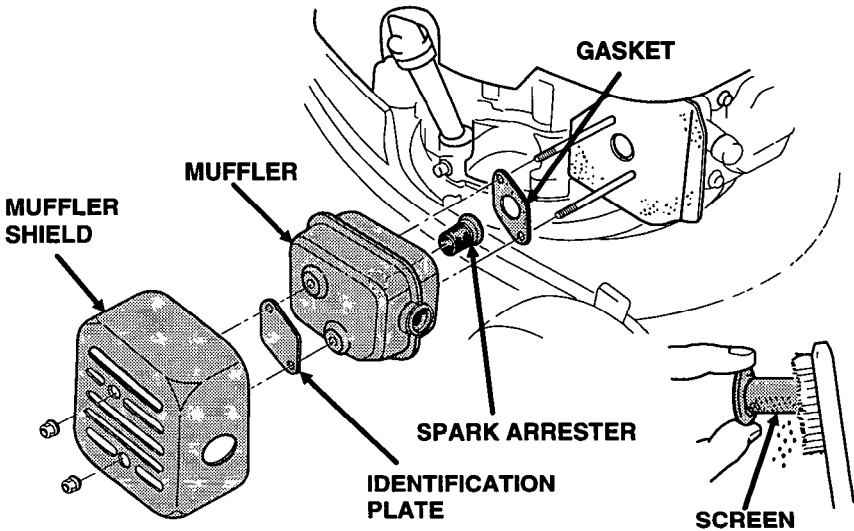

- A**
Air Cleaner Inspection.....20
Air Cleaner Service47
- B**
Blade(s):
 Inspection 17
 Installation57
 Removal56
- C**
Carburetor:
 Adjustment50
 High Altitude Operation50
Choke12 & 26
Clogged Mower Deck.....34
Clothing Recommendations...24
Component Identification 10
Contents 3
Control Cable Adjustments:
 Drive Clutch Cable (SDA) ..53
 Flywheel Brake Cable52
 Shift Cable (SDA).....54
Customer Service
 Information77
Cutting Height:
 Adjustment Levers 14
 Recommendations33
Cutting Width
 Recommendations33
- D**
Damage Prevention Message
 Definition 2
Description of Controls..... 12
Drive Clutch Lever (SDA):
 Cable Adjustment.....53
 Operation13 & 29
- E**
Emission Control System 42
Engine:
 Fuel Recommendations..... 51
 Maintenance 45
 Oil Change 45
 Oil Level 18
 Oil Recommendations 45
 Refueling..... 19
 Serial Number 11
 Specifications..... 71
 Starting..... 26
 Stopping..... 30
 Troubleshooting 59
- F**
Fallen Leaves; Bagging 34
Flywheel Brake Lever:
 Cable Adjustment 52
 Operation 13 & 28
Frame Serial Number 11
Fuel:
 Additive to Extend Storage
 Life 66
 Gasoline
 Recommendations..... 51
 Draining 67
 Refueling..... 19
- G**
Gasoline Recommendations . 51
Grass Bag:
 Cleaning.....58 & 64
 Inspection 22
 Removal and Installation ... 22
 Replacement..... 58

INDEX

H

- Handlebar Height Adj.....21
- Handlebar Folding.....69
- High Altitude Operation.....50

I

- Inspection Before Mowing:
 - Lawn.....16
 - Mower.....17
- Introduction 1

L

- Lawn:
 - Inspection Before Mowing .16
 - Mowing Tips33
 - Safe Mowing Practices31
- Leaves; Bagging34

M

- Maintenance:
 - Blade Removal and Installation56
 - Cable Adjustments.....52
 - Engine45
 - Grass Bag Cleaning & Replacement58
 - Importance40
 - Responsibility43
 - Safety41
 - Schedule44
 - Specifications74
- Mower Deck Clogging.....34
- Mowing:
 - Around Obstacles, Gravel, Objects32
 - Dry & Wet Grass34
 - Fallen Leaves.....34
 - Patterns.....35
 - Slopes31
 - Tips.....33

- When to Mow.....33
- Mulching Plug23

O

- Oil (for engine):
 - Change45
 - Level Check.....18
 - Recommendations.....45
- Operating the Controls for Mowing28

P

- Pre-Operation Check:
 - Lawn16
 - Mower17
- Publications76

S

- Safety:
 - Important Message to Parents7
 - Safe Mowing Practices31
 - Important Safety Information.....6
 - Safety Label Locations8
 - Safety Message Definitions 2
- Serial Numbers.....11
- Shift Lever (SDA):
 - Cable Adjustment54
 - Operation14 & 29
- Spark Arrester Service (Optional Equipment).....79
- Spark Plug Recommendations & Service48
- Specifications:
 - Capacities72
 - Dimensions.....72
 - Engine Design and Performance73
 - Maintenance74

Transmission Design and
 Performance 73
 Tuneup 74
 Weights 72
 Starting the Engine 26
 Stopping the Engine..... 30
 Storage:
 Placing In Storage..... 70
 Preparation..... 64
 Removing From Storage.... 70

T

Throttle Lever:
 Cable Inspection 55
 Operation 12 & 28
 Transmission (SDA):
 Drive Clutch Cable
 Adjustment..... 53
 Drive Clutch Lever
 Operation..... 13 & 29
 Shift Lever
 Operation..... 14 & 29
 Specifications 71
 Transporting 37
 Troubleshooting:
 Engine Problems..... 60
 Mowing and Bagging
 Problems 61
 Vibration Problems..... 61
 Tuneup Specifications..... 74

W

Washing:
 Grass Bag 58 & 64
 Mower..... 64

HONDA

31VE2700
00X31-VE2-7000



Printed on
Recycled Paper

CPI 170009505

PRINTED IN U.S.A.

