

HONDA

Power

Equipment

Owner's Manual
Lawn Tractor
H2013SDA & H2013HDA



HONDA

Harmony

Keep this owner's manual handy, so you can refer to it any time. This owner's manual is considered a permanent part of the lawn tractor and should remain with the tractor if resold.

The information and specifications included in this publication were in effect at the time of approval for printing. Honda Power Equipment Mfg., Inc. reserves the right, however, to discontinue or change specifications or design at any time without notice and without incurring any obligation whatever.



WARNING:



The engine exhaust from this product contains chemicals known to the State of California to cause cancer, birth defects, or other reproductive harm.

INTRODUCTION

Congratulations on your selection of the Honda H2013 lawn tractor. We are certain you will be pleased with your purchase.

We want to help you get the best results from your new lawn tractor and to operate it safely. This manual contains all the information on how to do that; please read it carefully.

We suggest you read the warranty policy to fully understand its coverage and your responsibilities of ownership. The warranty policy is a separate document that should have been given to you by your dealer.

When your lawn tractor needs scheduled maintenance, keep in mind that your Honda lawn tractor dealer is specially trained in servicing Honda lawn tractors and is supported by the parts and service divisions of American Honda. Your authorized Honda lawn tractor servicing dealer is dedicated to your satisfaction and will be pleased to answer your questions and concerns.

Best Wishes,

Power Equipment Division
American Honda Motor Co., Inc.

INTRODUCTION

SAFETY MESSAGES

Your safety and the safety of others is very important. We have provided important safety messages in this manual and on the lawn tractor. Please read these messages carefully.

A safety message alerts you to potential hazards that can hurt you and others. Each safety message is preceded by a safety alert symbol  and one of three words: DANGER, WARNING, or CAUTION.

These mean:

 **DANGER**

You **WILL** be **KILLED** or **SERIOUSLY HURT** if you don't follow instructions.

 **WARNING**

You **CAN** be **KILLED** or **SERIOUSLY HURT** if you don't follow instructions.

 **CAUTION**

You **CAN** be **HURT** if you don't follow instructions.

Each message tells you what the hazard is, what can happen, and what you can do to avoid or reduce injury.

DAMAGE PREVENTION MESSAGES

You will also see other important messages that are preceded by the word NOTICE.

This word means:

NOTICE

Your lawn tractor or other property can be damaged if you don't follow instructions.

The purpose of these messages is to help prevent damage to your lawn tractor, other property, or the environment.

CONTENTS

Turn to the beginning of each chapter for a complete list of subjects.

LAWN TRACTOR SAFETY	5
Important information about some specific hazards, and what you can do to prevent injury.	
CONTROLS	11
Identification of components and information about how the controls work.	
BEFORE OPERATION	19
How to fuel and check the lawn tractor, prepare your lawn tractor, and yourself before operation.	
OPERATION	29
Starting and stopping the engine, safe mowing practices, and mowing tips.	
TRANSPORTING	51
How to load and transport your lawn tractor safely.	
MAINTENANCE	53
When and how to perform routine inspection, service, and adjustments.	
TROUBLESHOOTING	103
What to check if you have a problem with the lawn tractor.	
STORAGE	111
How to protect the lawn tractor from rust and corrosion, and ensure that it will start easily when you want to use it again.	
SPECIFICATIONS	119
Dimensions, capacities, and other technical information.	
ADDITIONAL INFORMATION	123
Additional information, Honda publications available to you, and how to contact us if you have a question or a warranty repair problem.	
INDEX	128
QUICK REFERENCE INFORMATION	Inside back cover

LAWN TRACTOR SAFETY

This chapter explains what you need to know to operate your lawn tractor safely.

IMPORTANT SAFETY INFORMATION	6
Avoid Rotating Blades	6
Clear Mowing Area	6
Keep Shields in Place	6
Refuel with Care	7
Wear Protective Clothing	7
Turn Engine Off When Not Operating the Lawn Tractor	7
Operation on Slopes	7
Mowing Conditions	7
Mowing Near Roads	7
SAFETY LABEL LOCATIONS	8
CHILD SAFETY: A MESSAGE TO PARENTS	10

LAWN TRACTOR SAFETY

IMPORTANT SAFETY INFORMATION

Most accidents with lawn tractors can be prevented if you follow all instructions in this manual and on the lawn tractor. The most common hazards, according to accident statistics, are discussed below, along with the best way to protect yourself and others.

Avoid Rotating Blades

A rotating blade can cause serious cuts and even amputate fingers, hands, toes, or feet. Keep away from the mower deck whenever the engine is running. If you need to work around the deck to clear a grass accumulation or for any other reason, always shut off the engine and remove the key. Disconnect the spark plug cap, and wear heavy gloves when you need to clean the mower deck or handle a blade.

Clear Mowing Area

A lawn tractor blade can throw rocks and other objects with enough force to cause serious injury. Before mowing, carefully inspect the area and remove all stones, sticks, bones, nails, pieces of wire, and other loose objects. Never operate the lawn tractor over gravel or any other loose objects. Be aware if children are in the area; stop the lawn tractor and remove the ignition key to prevent accidental starting.

Keep Shields in Place

Guards and shields are designed to protect you from being hit by thrown objects and to keep you from touching hot engine parts and moving components. For your safety and the safety of others, keep all shields in place when the engine is running.

Refuel with Care

Gasoline is extremely flammable, and gasoline vapor can explode. Allow the engine to cool if the lawn tractor has been in operation. Refuel only outdoors in a well-ventilated area with the engine OFF. Never fill the fuel tank beyond the maximum fill mark. Never smoke near gasoline, and keep other flames and sparks away. Always store gasoline in an approved container.

Wear Protective Clothing

Wearing protective clothing will reduce your risk of injury. Long pants and eye protection reduce the risk of injuries from thrown objects. Sturdy shoes with aggressive soles provide better traction on the lawn tractor's platform and pedals.

Turn Engine Off When Not Operating the Lawn Tractor

If you need to leave the lawn tractor for any reason, even just to inspect the lawn ahead, always turn the engine off. And take the key if you go farther away.

Operation on Slopes

This lawn tractor is intended for use on relatively flat terrain. Operating the lawn tractor on slopes exceeding 10 degrees (17% grade) could cause the lawn tractor to tip over. Always mow up and down slopes, never across. When mowing up and down slopes, empty the optional grass bags when they are half full.

Mowing Conditions

Mow only in daylight or good artificial light. Do not drive the lawn tractor at night or under poor light conditions.

Mowing Near Roads

Always watch for vehicle traffic when operating the lawn tractor near roads and driveways. Never drive the lawn tractor on public roads.

LAWN TRACTOR SAFETY

SAFETY LABEL LOCATIONS

These labels warn you of potential hazards that can cause serious injury. Read them carefully. If a label comes off or becomes hard to read, contact your Honda lawn tractor dealer for a replacement.

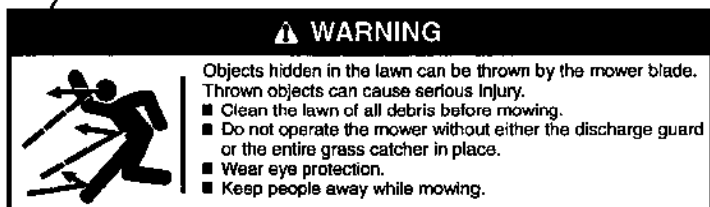
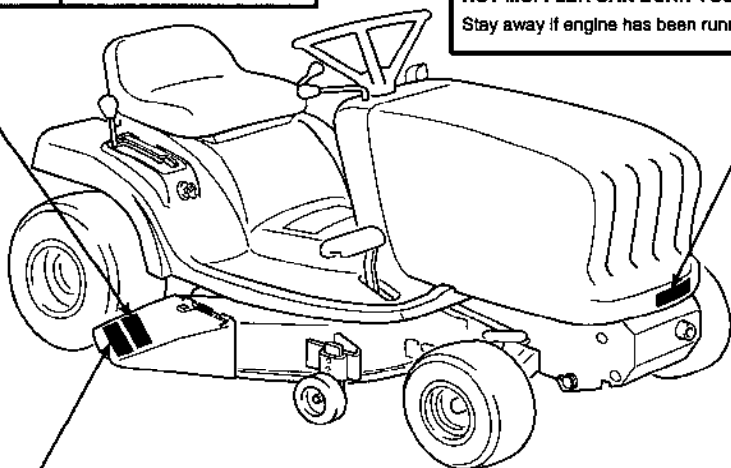
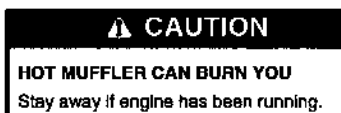

771NAAAA.C

LAWN TRACTOR SAFETY

⚠ WARNING

- Improperly driving on slopes or uneven terrain can cause the mower to tip over and you can be seriously hurt or killed.
- Objects hidden in the lawn can be thrown by the blade and can cause serious injury.
Read "Mower Safety" and "Safe Mowing Tips" in your Owner's Manual carefully.
- The rotating blade can cause serious injury
 - Keep hands and feet away from the mower deck
 - Stop engine before leaving operator's position.
- Do not allow children to ride as passengers.
They can fall or be thrown off causing serious injury or death.
Read "Child Safety" in the Owner's Manual carefully.

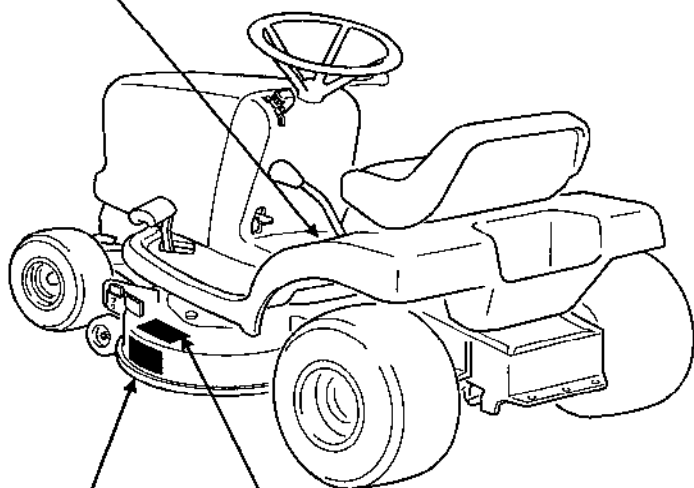

⚠ DANGER



SHARP BLADE

You will be seriously cut by the rotating blade.

Keep hands and feet away when engine is running.

⚠ CAUTION

The tension pulley is under spring pressure. When you relieve pressure on the belt, the pulley can snap back on your hand or fingers.

Wear heavy gloves to protect your hands. Keep your hands from between pulleys.

771NABAA.CDR

LAWN TRACTOR SAFETY

CHILD SAFETY: A MESSAGE TO PARENTS

YOUR CHILD'S SAFETY IS VERY IMPORTANT to Honda. Read this message if you decide to permit your youngster to operate this lawn tractor. Lawn tractors are tools, not toys. As with any equipment, bad judgments can result in serious injuries. You can help prevent accidents by making good decisions about if, when, and how your youngster operates this equipment.

The first question you'll need to ask is whether your youngster is capable of operating this lawn tractor safely. Remember, young people vary widely, and **AGE IS NOT THE ONLY FACTOR**.

Physically, a youngster must be **LARGE ENOUGH AND STRONG ENOUGH** to easily start the lawn tractor and control its direction. The youngster also needs enough size, strength, and coordination to comfortably reach and operate the controls.

Another, tougher question you need to ask is if your youngster has enough **MATURITY AND RESPONSIBILITY** to safely operate this lawn tractor. Does the young person think through problems and come to logical solutions? Be honest! Anyone who takes unnecessary risks and doesn't obey rules should not operate this lawn tractor.

If you decide that your son or daughter can handle the lawn tractor safely, **CAREFULLY READ THE OWNER'S MANUAL** with your youngster. Make sure you both understand all instructions and safety information. Also, be sure your youngster wears sturdy shoes and other protective clothing when operating or handling the lawn tractor.

SUPERVISION is important. Walk behind your youngster during the first few minutes of mowing. Even after the youngster is confident, do not let them use the lawn tractor without supervision. An adult should also be present during refueling and maintenance. Be sure the lawn tractor is properly maintained and kept in safe operating condition.

By always placing safety first, your youngster will acquire useful skills and a sense of accomplishment. And you'll both get the best results from your lawn tractor.

CONTROLS

This section helps you to identify the lawn tractor controls, what they do, and how they work.

CONTROL LOCATIONS	12
DESCRIPTION OF CONTROLS.....	14
Seat.....	14
Fuel Valve	14
Ignition Switch	14
Shift Lever	15
Height Adjustment Lever	15
Clutch Pedal (gear transmission model only).....	15
Brake Pedal.....	16
Parking Brake Lever	17
Throttle Lever / Choke	17
PTO Clutch Lever.....	18
Transmission Release (hydrostatic transmission model)	18

CONTROLS

CONTROL LOCATIONS

Use the two illustrations on these pages to locate and identify the most frequently used controls.

- [1] PTO CLUTCH LEVER
- [2] TRANSMISSION SHIFT LEVER
- [3] IGNITION SWITCH
- [4] BRAKE PEDAL

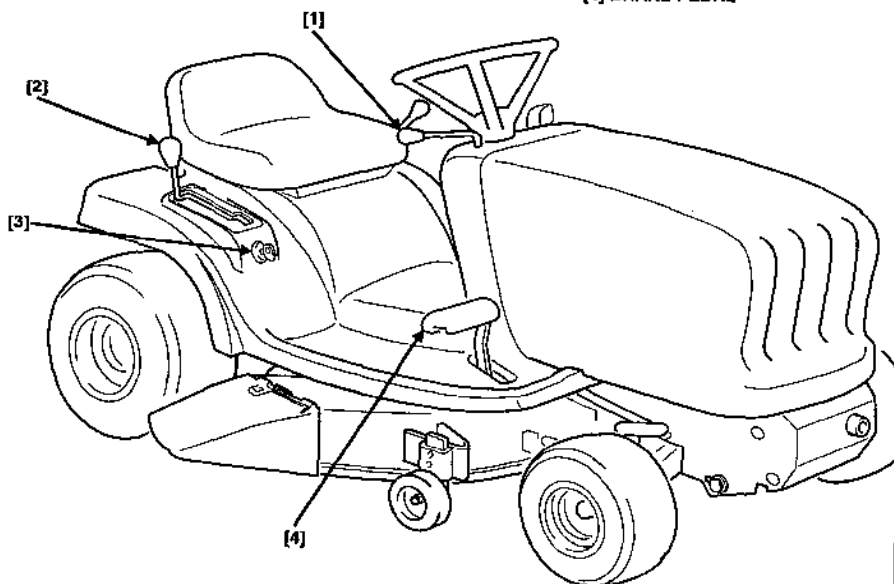

771NAAAB.CI

- [1] THROTTLE LEVER / CHOKE
- [2] FUEL VALVE (under engine hood, on carburetor)
- [3] PARKING BRAKE LEVER
- [4] CLUTCH PEDAL (gear transmission model only)
- [5] SEAT LOCK ROD (under seat)
- [6] MOWER DECK HEIGHT ADJUSTMENT LEVER
- [7] TRANSMISSION RELEASE LEVER (hydrostatic transmission model)

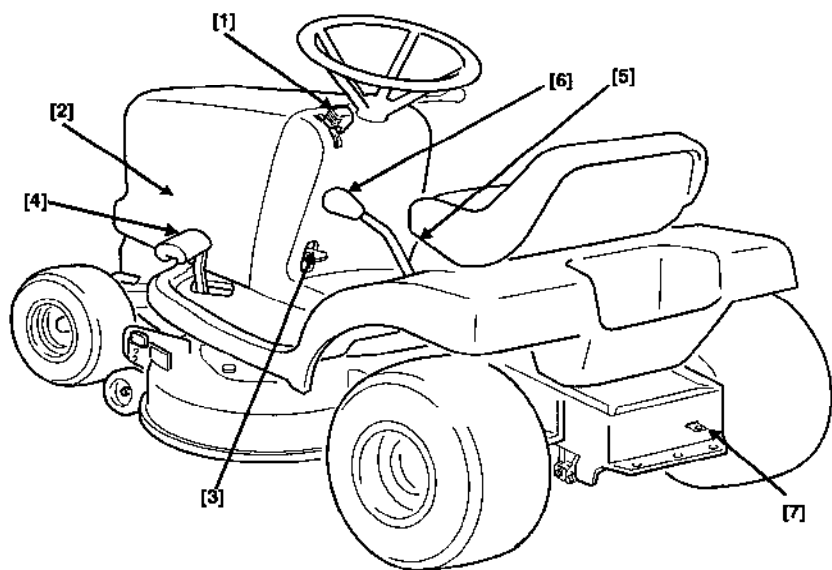

771NABAB.CDR

CONTROLS

DESCRIPTION OF CONTROLS

You will use these controls every time you operate the lawn tractor. Your lawn tractor uses colors to identify control types.

Orange levers and knobs are used to control the movement of the lawn tractor. For example, the parking brake lever, throttle lever, and shift lever are color coded orange.

Yellow controls identify attachment controls, such as the hand grip on the PTO clutch lever that is used to start and stop movement of the mower deck blades.

Seat

The seat can be adjusted back and forth for operator comfort. The seat may also be raised and locked for battery access (see the *Maintenance* chapter for details).

Fuel Valve

The fuel valve is located on the carburetor, on the left side of the engine, underneath the engine hood. Pushing the fuel valve handle toward the engine allows fuel to flow from the fuel tank to the carburetor. The fuel valve must be ON to start the engine and should be OFF when the lawn tractor is not in use, or when transporting the lawn tractor.

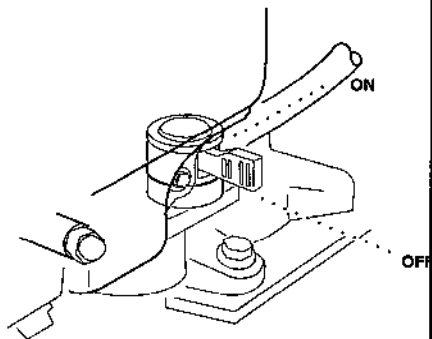

772CAAAC.CDI

Ignition Switch

The ignition switch is used to start and stop the engine. The key can only be inserted and removed when the switch is OFF.

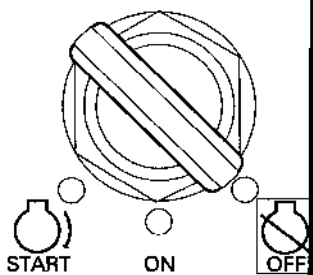

772CABAB.CDI

Shift Lever

Gear Transmission Model: This lever is used to control the ground speed. Gears 1-3 are typically used when mowing. 4th and 5th gears are used when transporting the lawn tractor and REVERSE is used when backing up.

Hydrostatic Transmission Model: This lever is used to control ground speed with infinite adjustment. The MOWING range is used when mowing, TRANSPORT is used when moving the lawn tractor between two points, and REVERSE is used when backing up.

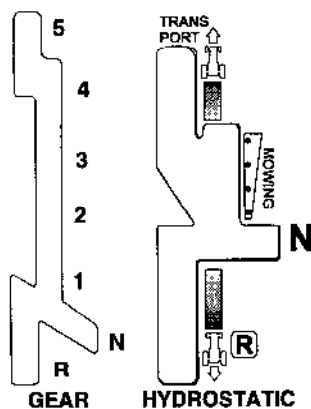

772CADAC.CDR

Height Adjustment Lever

This lever is used to raise and lower the mower deck. The numbers along the lever can be used to reference the distance of the mower blades tips from the ground.

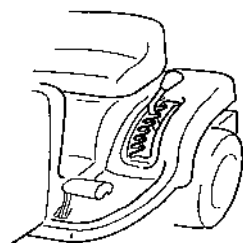

771CAAAA.CDR

Clutch Pedal (gear transmission model only)

The clutch pedal is used when shifting between gears and when stopping and starting the lawn tractor. Pressing the clutch pedal all the way down releases the tension of the drive belt between the engine and transmission. This allows you to move the shift lever smoothly between gear selections.

The clutch pedal is automatically pressed down when the brake pedal is pressed down. The clutch pedal will not release unless the brake pedal is also released.

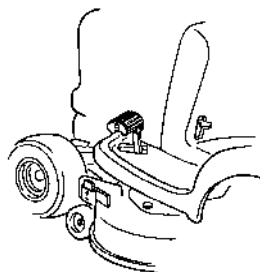

771
CABAA.CDR

CONTROLS

Brake Pedal

Gear Transmission Model: The brake pedal applies a brake to the rear wheels. The brake pedal is linked to the clutch pedal. When the brake pedal is pressed down, the clutch pedal is also pressed down. When the brake pedal is released, it should be released first, then the clutch pedal.

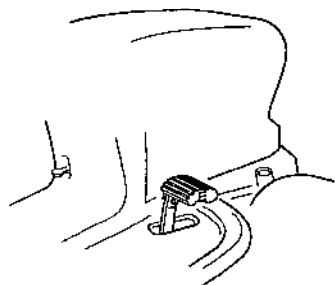

771CACAA.CDR

The brake pedal must be pressed all the way down before engaging the parking brake lever.

NOTICE

Partially pressing the brake pedal without first pressing the clutch pedal all the way down can cause the drive belt to wear prematurely.

Hydrostatic Transmission Model: The brake pedal is linked to both the shift lever and the rear wheel brake. When the brake pedal is *fully* pressed, the shift lever automatically moves to **NEUTRAL** and a brake is applied to the rear wheels.

When the shift lever is not in **NEUTRAL** and the brake pedal is *partially* pressed, the shift lever moves toward **NEUTRAL**.

Parking Brake Lever

This lever is used to prevent movement of the lawn tractor when parked. The parking brake lever should always be set before getting off the lawn tractor. The parking brake lever should be released before moving the shift lever into any gear.

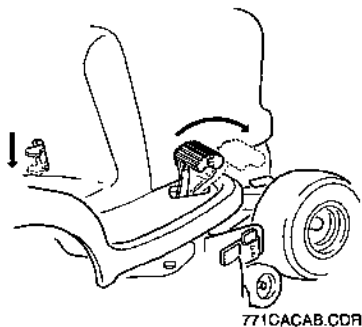

The parking brake is set by pressing and holding the brake pedal all the way down, then move the parking brake lever down. The brake pedal remains held down by the parking brake lever.

To release the parking brake, hold down the brake then move the parking brake lever up. The brake pedal can then be released.

The engine stops if you rise off the seat without the parking brake engaged. You should always move the shift lever to **NEUTRAL** before setting the parking brake.

Throttle Lever / Choke

The throttle lever controls engine speed and is also used to set the choke on or off. When starting a cold engine, the throttle should be set to **CHOKE**, or to **FAST** if the engine is warm.

For the best cut quality, the throttle should be set to **FAST** when mowing. Avoid using the throttle to control the ground (travel) speed of the lawn tractor; instead, use the shift lever.

The **SLOW** position on the throttle is used to idle the engine, for example, before turning the engine off.

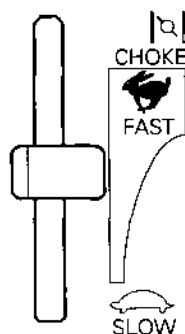

771CAEAA.CDR

CONTROLS

PTO Clutch Lever

PTO stands for **Power Takeoff** and refers to the part of your lawn tractor where engine power is applied to an attachment (such as the mower deck) through a belt. In this manual, all references to the PTO assume the PTO is used to power the mower deck.

The forward position is **ON**; this starts the mower blades spinning. The rear position is **OFF**, and this stops the mower blades from spinning.

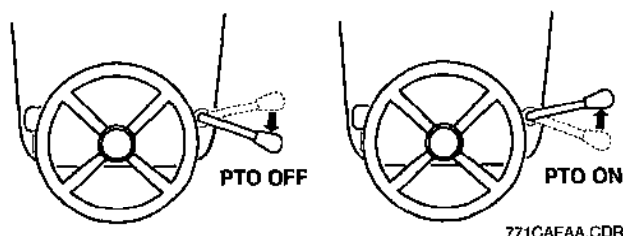

The PTO clutch lever should always be engaged with a smooth and quick motion. You should always disengage the PTO when not actually mowing. The lawn tractor won't start if the PTO is **ON**. The engine will stop if you rise off the seat when the PTO lever is **ON**.

Transmission Release (hydrostatic transmission model)

This control is used to engage or disengage the hydrostatic transmission. When operating the lawn tractor under its own power, leave the control in the **ENGAGED** position. If you ever need to push the lawn tractor, pull the control out and lock it in the **RELEASED** position.

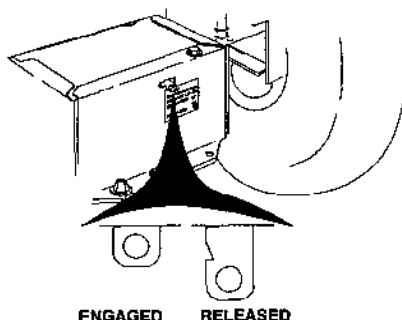

NOTICE

Pushing or towing the lawn tractor with the transmission release lever in the **ENGAGED** position will damage the hydrostatic transmission.

BEFORE OPERATION

This chapter explains how to fuel and check your lawn tractor to be sure it is ready, and it tells you how to prepare your lawn and yourself before you begin mowing.

CHECK YOUR LAWN	20
Objects	20
People and Pets	20
Lawn.....	20
CHECK YOUR LAWN TRACTOR	21
General Items.....	21
Engine Oil Level	21
Tire Pressure.....	22
Grass Bag (optional kit).....	22
Brake Pedal.....	23
Parking Brake.....	23
Transmission Release (hydrostatic transmission model)	23
Hydrostatic Fluid Level (hydrostatic transmission model)	23
Muffler and Exhaust Area	23
Drive Belt.....	23
Fuel	24
Cooling Air Intake Path and Air Filters	25
Battery Electrolyte	25
Mower Deck	25
ARE YOU READY TO MOW?	28
Knowledge.....	28
Clothing	28

BEFORE OPERATION

There are three areas to be checked before using the lawn tractor:

- Check Your Lawn
- Check Your Lawn Tractor
- Are YOU Ready to Mow?

These are described in the following sections.

CHECK YOUR LAWN

For your safety and the safety of others, always inspect the area before mowing.

Objects

Anything which can be picked up by the blade and thrown is a potential hazard to you and others. Look for things like stones, sticks, bones, nails, and wire, and remove them from the mowing area.

People and Pets

People and animals near the mowing area can move into your mowing path or into a position where they could be struck by thrown objects. Clear the area of people, especially children and pets. Their safety is your responsibility.

Lawn

Check the length and condition of the grass. Adjust your mowing speed and cutting height accordingly.

Avoid mowing wet grass. Not only does mowing wet grass result in poor cut quality, it also affords poor traction, increasing the risk of loss of control of your lawn tractor.

CHECK YOUR LAWN TRACTOR

For your safety and the service life of your equipment, always inspect your lawn tractor before using it. Before beginning your pre-operation checks, be sure:

- The lawn tractor is parked on a level surface.
- The PTO clutch lever is **OFF** and the shift lever is in **NEUTRAL**.
- The ignition switch is **OFF** and the key is removed.
- The parking brake is set.

General Items

Walk around the lawn tractor and check its general condition. Look around and underneath it for signs of fluid leaks.

Remove any excessive dirt and debris, especially around the engine, mower deck, and moving components. Look for signs of damage. Check nuts, bolts, screws, and pins for tightness.

Keep all shields and covers in place while operating the lawn tractor. If you find any problems, have them repaired before mowing.

Engine Oil Level

1. Raise the engine hood (page 63). The oil filler cap is located on the right side of the engine.
2. Clean the area around the oil filler cap, unscrew it, and wipe the dipstick with a clean cloth.

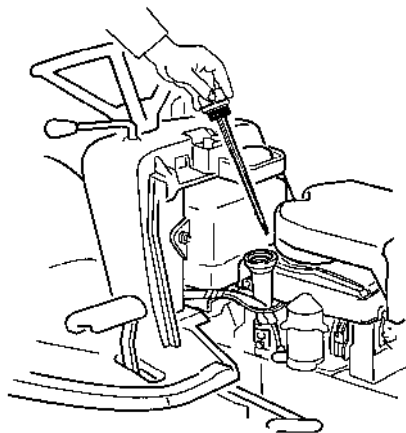

771EAAAA.CDR

BEFORE OPERATION

3. Insert the dipstick as shown here (don't screw it back in).
4. If the oil level is low (near the bottom), add enough of the recommended oil (see page 66) to bring the level to the upper limit. Recheck the oil level after adding new oil.

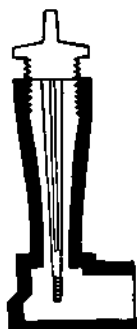

LM-AADAA.CDR

5. If the oil level is close to the upper limit mark, no additional oil is needed. Replace the dipstick and screw it back in securely. Do not overfill.

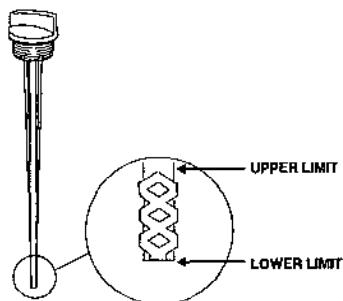

772EABAB.CDR

NOTICE

Running the engine at a low oil level or with no oil causes engine damage.

Tire Pressure

Make sure all tires are properly inflated:

Tire pressure: Front: 14 psi (98 kPa)
Rear: 10 psi (69 kPa)

Grass Bag (optional kit)

If your lawn tractor has the optional grass bag kit installed, check the kit for proper installation and verify the grass bags are in good condition.

Brake Pedal

(Gear Transmission Model)

Verify that the clutch pedal operates when the brake pedal is pressed, and that there is not excessive freeplay in the brake pedal. Also inspect the brake wear indicator (page 78).

(Hydrostatic Transmission Model)

Move the shift lever out of **NEUTRAL**. Press the brake pedal all the way down. Make sure the shift lever returns to **NEUTRAL**.

Parking Brake

Make sure the brake and clutch pedals remain locked down in place when the parking brake is set (page 17).

Transmission Release (hydrostatic transmission model)

Make sure this lever is in the **ENGAGED** position before operating the lawn tractor (page 18).

Hydrostatic Fluid Level (hydrostatic transmission model)

The hydrostatic fluid level should be between the two raised lines on the bottom left corner of the reservoir. If the fluid level is below the bottom line, add enough Honda Hydrostatic Transmission Fluid to bring the level up to the top line (page 100).

Muffler and Exhaust Area

Inspect the muffler and exhaust area; make sure it is free of grass or any other obstructions.

Drive Belt

Verify that the drive belt is in good condition (page 96).

BEFORE OPERATION

Fuel

Capacity: 1.3 US gal (5.3 ℓ)

Minimum pump octane rating: 86

Refueling

Refuel in a well-ventilated area before starting the engine. If the engine has been running, allow it to cool before refueling. Avoid overfilling or spilling fuel. Fuel the lawn tractor with pump octane 86 or better unleaded fuel (see page 73). Make sure the fuel cap is secure.

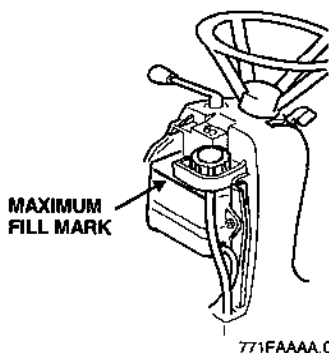

771FAAAA.C

1. Raise the hood, remove the fuel cap, and check the fuel level.
2. Avoid overfilling or spilling fuel. Fuel to the maximum fill mark.



WARNING

Gasoline is highly flammable and explosive. You can be burned or seriously injured when refueling.

- Stop the engine and keep heat, sparks, and flame away.
- Refuel only outdoors.
- Wipe up spills immediately.

2. Never refuel the lawn tractor inside a building where fumes may reach a flame or spark. Keep gasoline away from appliance pilot lights, electric motors, etc.
3. Spilled fuel not only creates a fire hazard, it can cause environmental damage. Wipe up spills immediately. Dispose of gasoline properly.

NOTICE

Fuel can damage paint and plastic. Don't spill fuel when filling the fuel tank. Damage caused by spilled fuel is not covered under warranty.

Cooling Air Intake Path and Air Filters

Raise the engine hood (page 63), then make sure the cooling air intake screen on the front of the engine is clear of grass and debris. Inspect the engine air cleaner filter elements (page 64) for damage or excessive dirt and dust.

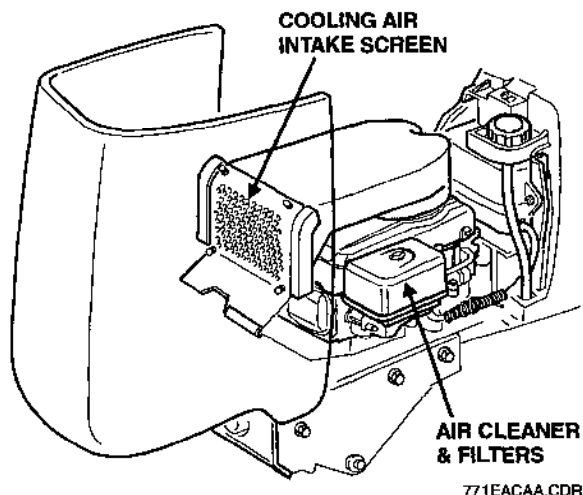

Battery Electrolyte

Inspect the electrolyte level in the battery; add distilled water if needed (page 74).

Mower Deck

Clear the top and bottom of the mower deck of any grass, debris, etc. Make sure the discharge guard is properly installed. If your mower is equipped with the optional mulch kit, be sure the ring pin, cover plate, and swirl guide are also properly installed.

If the optional grass bag kit is installed, verify that all parts of the kit are properly installed and the grass bags are in good condition. Refer to the operator's manual supplied with the grass bag kit for specific instructions.

BEFORE OPERATION

Mulching, Side-discharge, or Bagging?

The mower deck on your lawn tractor was manufactured with high-lift blades for side-discharge mowing. An optional kit is available to convert your mower for mulching.

SIDE-DISCHARGING TO MULCHING CONVERSION

Your mower deck is a side-discharge model. For mulching you must purchase and have the optional mulching kit installed. Refer to the operator's manual supplied with the kit for specific installation and operation instructions. Be sure the side-discharge chute cover remains attached to the mower deck when the optional mulch kit is installed.

SIDE-DISCHARGE TO BAGGING

You must have the optional grass bag kit installed. Refer to the operator's manual supplied with the kit for specific installation and operation instructions. Be sure the side-discharge chute cover remains attached to the mower deck when the optional grass bag kit is installed.

MULCHING TO BAGGING

You must have the optional grass bag kit installed. Refer to the operator's manual supplied with the kit for specific installation and operation instructions. Be sure the side-discharge chute cover remains attached to the mower deck when the optional grass bag kit is installed.

Under many conditions, the mulching blades work when operating in the bagging mode. However, maximum bagging performance requires replacing the mulching blades with high-lift blades. These blades may be purchased from an authorized Honda lawn tractor dealer.

BAGGING TO SIDE-DISCHARGING OR BAGGING TO MULCHING

Refer to the operator's manual supplied with the optional grass bag kit for specific instructions on how to convert the mower deck from bagging to side-discharge or mulching operation.

Blades

Make sure the mower deck blades are in good condition and the blade bolts are properly tightened.

The blades are subject to wear during operation and should be inspected each time the lawn tractor is used. Dull blades can be sharpened, but a blade that is worn out, bent, cracked, or otherwise damaged must be replaced.

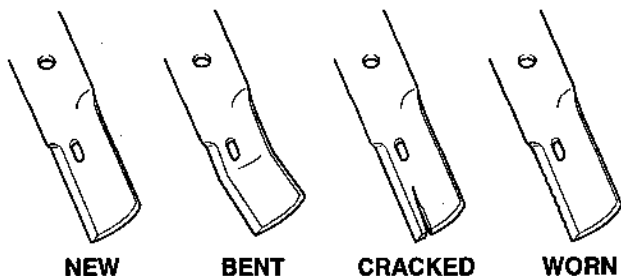

CM-ABAAA.CDR

Height Adjustment Lever

Set this lever to the appropriate position for mowing conditions (page 43).

Anti-Scalp Rollers

These rollers should be positioned according to the mower deck height (page 79).

BEFORE OPERATION

ARE YOU READY TO MOW?

Your safety is your responsibility. A little time spent in preparation will significantly reduce your risk.

Knowledge

Read and understand this manual. Know what the controls do and how to operate them.

Familiarize yourself with the lawn tractor and its operation before you begin mowing. Know what to do in case of emergencies.

Clothing

Wearing protective clothing will reduce your risk of injury.

Long pants and eye protection reduce the risk of injuries from thrown objects.

Sturdy shoes with aggressive soles will help protect your feet and give you better traction on the pedals and platform of the lawn tractor.

While the sound level of the lawn tractor is well within safe limits, hearing protection will further protect your hearing.

OPERATION

This chapter tells you how to operate the lawn tractor safely and effectively.

MOWING PRECAUTIONS	30
STARTING THE ENGINE	31
DRIVING THE LAWN TRACTOR	33
Steering	33
Braking	34
Adjusting Ground Speeds	35
Mowing	37
STOPPING THE LAWN TRACTOR	38
Emergency Stop	38
Normal Stop	38
SAFE MOWING PRACTICES	39
Operation on Slopes	40
Obstacles	41
Gravel and Loose Objects	42
MOWING TIPS	43
When to Mow	43
Cutting Height	43
Ground Speed	44
Cutting Width	44
Blade Speed	44
Blade Sharpness	45
Grass and Moisture	45
Fallen Leaves	45
Clogged Mower Deck	45
Mowing Patterns	46
AFTER MOWING	47
Mower Deck Cleaning	47
Cleaning Other Areas	47
TOWING	48
Towing Safety	48
Towing Weight Limits	49

OPERATION

MOWING PRECAUTIONS

Before operating the lawn tractor for the first time, please review the *IMPORTANT SAFETY INFORMATION* beginning on page 6 and the previous section, titled *BEFORE OPERATION*.

Even if you have operated other lawn tractors, take time to become familiar with how this lawn tractor works, and practice in a safe area until you build up your skills.

Never tamper with, or alter any of the controls or safety devices on the lawn tractor.

For your safety, avoid starting or operating the engine in an enclosed area such as a garage. Your lawn tractor's exhaust contains poisonous carbon monoxide gas which can collect rapidly in an enclosed area and cause illness or death.

STARTING THE ENGINE

Start the engine outside in an open area with good ventilation.

1. Locate the fuel valve on the carburetor, under the engine hood. Move the fuel valve to **ON**. Lower the engine hood and sit in the operator's seat.
2. Make sure the PTO lever is **OFF** (disengaged), the parking brake is set, and the shift lever is in **NEUTRAL**. The starter will not operate unless these controls are properly set.

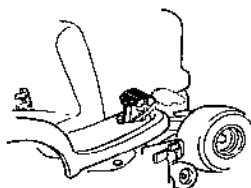
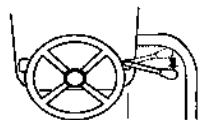
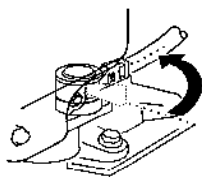

3. To start a cold engine, move the throttle lever to **FAST**, then press the lever inward, slightly past a detent to **CHOKE**. To restart a warm engine, move the throttle lever to **FAST**.
4. Insert the ignition key into the ignition switch. Turn the key clockwise to **START** and hold it there briefly until the engine starts. When it does, let the key return to the **ON** position.

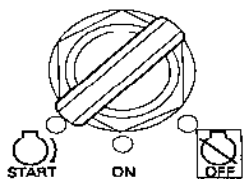
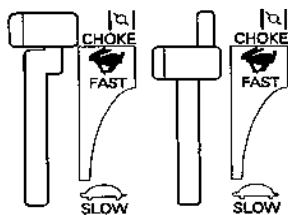
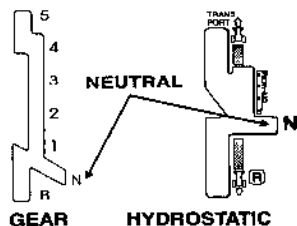

771UAAAA.CDR

OPERATION

NOTICE

Holding the ignition key in the **START** position for more than five seconds may damage the starter.

5. If the engine fails to start, wait at least ten seconds before trying again. If you can't get the engine to start after multiple tries, refer to *Troubleshooting* on page 103.
6. After the engine has started, slowly move the throttle lever from **CHOKE** to a point halfway between **SLOW** and **FAST** while the engine warms up.
7. Once the engine has warmed, you should keep the throttle in the **FAST** position while mowing. This keeps the blades spinning at the proper speed (when the PTO is **ON**) and provides the best cut quality.

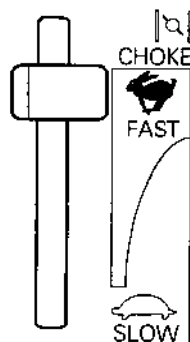

771CAEAB.CDF

Do not use the throttle lever to adjust the lawn tractor ground speed. Use the shift lever to select a different speed instead. Slowing the lawn tractor's ground speed with the throttle lever causes the blades to spin slower, and cut quality will suffer.

DRIVING THE LAWN TRACTOR

Once the lawn tractor is moving forward, you'll need to know how to steer correctly, adjust speed, begin mowing, and how to stop.

Steering

To make it easier to cut various lawns, your lawn tractor is very maneuverable and can turn quickly.

WARNING

Turning sharply when using higher ground speeds can cause the lawn tractor to lose traction.

The lawn tractor can tip over, and you can be injured or killed.

Avoid sharp turns when using higher gears.

After using the lawn tractor for a while, you'll get a better feel for how much effort to use on the steering wheel for a particular turn.

The speed of the lawn tractor greatly affects how the steering responds. For this reason, you should shift the transmission to a lower ground speed before entering turns.

Avoid turning the lawn tractor when operating on a sloped surface. See *Operation on Slopes* later in this chapter for more details.

OPERATION

Braking

For best control, avoid stopping the lawn tractor on sloped surfaces.

Gear Transmission Model

1. When approaching the area where you wish to stop, smoothly press the clutch pedal all the way down, and hold it there. If necessary, press the brake pedal down, but only do this when the clutch pedal is pressed first.
2. Once the lawn tractor has fully stopped, hold the clutch and brake pedals down, and move the shift lever to **NEUTRAL**. If this is an extended stop, set the parking brake.

NOTICE

Partially pressing the brake pedal without first pressing the clutch pedal can cause the drive belt to wear prematurely. Press the clutch pedal down first, before pressing the brake pedal.

Hydrostatic Transmission Model

The hydrostatic transmission allows two options of braking. You can operate the shift lever or the brake pedal to slow down or stop.

USING THE SHIFT LEVER

To reduce the ground speed of the lawn tractor, move the shift lever toward **NEUTRAL**. Moving the shift lever fully into **NEUTRAL** will bring the lawn tractor to a full stop, as long as the ground is level. If the lawn tractor is on a slope, you must press and hold the brake pedal to completely stop the lawn tractor.

USING THE BRAKE PEDAL

Partially pressing the brake pedal causes the shift lever to move toward **NEUTRAL**. This action causes the hydrostatic transmission to act as a hydraulic brake and the lawn tractor slows down. Pressing the brake pedal all the way down moves the shift lever fully into the **NEUTRAL** position and applies a mechanical brake to the rear wheels.

Adjusting Ground Speeds

Your Honda lawn tractor is equipped with a transmission that offers multiple ground speeds. The shift lever is used to select the appropriate ground speed for the task at hand.

When you need to speed up or slow down the lawn tractor, use the shift lever (not the throttle) to change the ground speed.

On slopes or hills, use a slower shift lever setting to maintain a controllable, steady speed. Also, use slower ground speeds under the following conditions:

- For sharp turns
- Mowing in narrow areas or near trees
- When edging or trimming near obstructions
- Cutting tall or very thick grass

REVERSE is used to back up the lawn tractor. Before traveling in **REVERSE**, make sure the PTO is **OFF**, and the path is clear of people, pets and obstructions.

Gear Transmission Model

1st - 3rd gears work best for most mowing jobs. 4th and 5th gears should be used only for transporting the lawn tractor (when the PTO is **OFF**) and are not recommended for mowing. Cut quality will suffer if you mow with 4th or 5th gear.

Always use the clutch when changing forward gears. If shifting between any forward gear and **REVERSE**, use the clutch *and* brake pedals to bring the lawn tractor to a full and complete stop.

⚠ WARNING

Operating the shift lever on a sloped surface can cause the lawn tractor to lose traction

The lawn tractor can tip over, and you can be killed or seriously injured.

Do not operate the shift lever while the lawn tractor is on a sloped surface.

OPERATION

Always use the clutch pedal when shifting gears. The lawn tractor pulls away from a complete stop in any gear. This means you can start off from a complete stop when any gear is selected.

Keep the shift lever in the **MOWING** range (gears 1-3) when actually mowing grass. The **TRANSPORT** range (gears 4-5) should only be used for transporting the lawn tractor (when the PTO clutch lever is **OFF**) and is not recommended for mowing.

SHIFTING FROM A FORWARD GEAR TO ANOTHER FORWARD GEAR

1. Push the clutch pedal all the way down.
2. Move the shift lever to the desired gear position.
3. Gently release the clutch pedal.
4. You don't need to bring the lawn tractor to a full stop if shifting from one forward gear to another.

SHIFTING BETWEEN ANY FORWARD GEAR AND REVERSE

1. Press the clutch pedal all the way down, then press the brake pedal all the way down to stop the lawn tractor.
2. Move the shift lever to the desired gear.
3. Gently release the brake pedal, then the clutch pedal.

Hydrostatic Transmission Model

The hydrostatic transmission in your lawn tractor offers you an infinitely variable range of speeds. This means you only need to move the shift lever to change the forward ground speed and to move in reverse.

Keep the shift lever in the **MOWING** range when actually mowing grass. The **TRANSPORT** range should only be used for transporting the lawn tractor (when the PTO clutch lever is **OFF**) and is not recommended for mowing.

ADJUSTING FORWARD SPEED

1. To make the lawn tractor move faster when moving forward, push the shift lever forward, away from **NEUTRAL**.
2. To slow down, pull the shift lever back toward **NEUTRAL**.

ADJUSTING REVERSE SPEED

1. To make the lawn tractor move faster in **REVERSE**, pull the shift lever backward, away from **NEUTRAL**.
2. To slow down, push the shift lever toward **NEUTRAL**.

Mowing

When ready to begin mowing, approach the mowing area at a reduced ground speed. Bring the lawn tractor to a full stop, and check the position of the height adjustment lever. You may have to make some trial cuts to determine which setting is best for your lawn.

To begin mowing, make sure the throttle is set to **FAST**, then push the PTO clutch lever forward to **ON** with a smooth, quick motion. When you do, the blades start to turn. To stop the blades from turning, pull the PTO clutch lever back to **OFF**.

Avoid engaging the PTO clutch lever when the mower deck is set low and the grass is thick or heavy. The engine may stall under such conditions.

NOTICE

Do not operate the PTO clutch lever in an attempt to clear a clogged mower deck. Doing so can damage the mower deck belt.

Keep the shift lever set to a speed within the **MOWING** range when mowing.

See the *Mowing Tips* section later in this chapter for details on getting the best cut possible from the lawn tractor.

OPERATION

STOPPING THE LAWN TRACTOR

Emergency Stop

1. Press the brake pedal all the way down and hold it there.
2. Turn the ignition switch to **OFF**. Disengage the PTO clutch lever.
3. Set the parking brake.

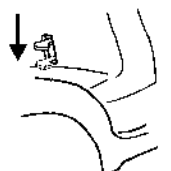
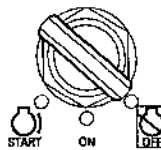
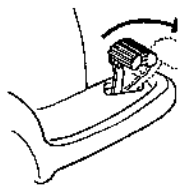

771UABAA.6

Normal Stop

1. Bring the lawn tractor to a full stop.

GEAR TRANSMISSION MODEL: Use the clutch pedal first, then the brake pedal to stop the lawn tractor. Move the shift lever to **NEUTRAL**.

HYDROSTATIC TRANSMISSION MODEL: Move the shift lever to **NEUTRAL**, then press and hold the brake pedal all the way down.

2. Move the PTO lever to **OFF**.
3. Move the throttle lever to **SLOW**.
4. Set the parking brake.
5. Remove your foot from the brake pedal.
6. Turn the ignition switch **OFF**.
7. Remove the ignition switch key.
8. Turn the fuel valve **OFF**.

Try to park on level ground. If you must park the lawn tractor on a slope, set the parking brake and block the wheels to prevent the lawn tractor from rolling. Always remove the key when leaving the lawn tractor unattended to prevent unauthorized use.

SAFE MOWING PRACTICES

For your safety, keep all four wheels on the ground, and be careful to avoid losing control of the lawn tractor.

Keep a firm grip on the steering wheel. Be very careful when mowing uneven or rough ground.

Do not operate the lawn tractor near embankments, dropoffs or ditches. The lawn tractor could suddenly turn over if a wheel is near the edge and it caves in or gives way.

Do not attempt to stabilize the lawn tractor by putting your foot on the ground. Keep your feet on the platform and near the pedals.

Take extra care when mowing near blind corners, shrubs, trees or any other objects that may obscure your vision. If you do strike an object: stop, set the parking brake, remove the ignition key and inspect the lawn tractor for damage. Repair any damage before any further operation.

WARNING

The blades are sharp and spin at high speed.

A spinning blade can cut you severely and can amputate fingers and toes.

- Wear protective footwear.
- Keep your hands and feet away from the mower deck while the engine is running.
- Stop the engine before performing any adjustment, inspection, or maintenance.

OPERATION

Operation on Slopes

Never mow on a sloped surface greater than 10 degrees (17% grade), since this can cause the lawn tractor to tip over. Use a lower gear for better control, and avoid sudden stops or starts when on a sloped surface. If you are unsure of the grade, obtain an inclinometer from a hardware store to measure the area in question.

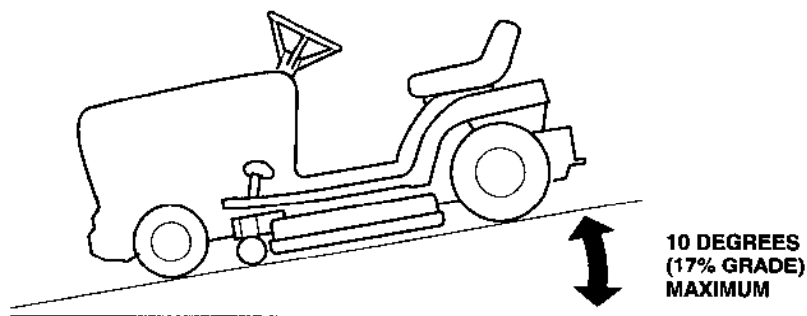

771NACAA.CDR

Always mow up and down a sloped surface, never across. Avoid sharp turns when operating the lawn tractor on a sloped surface. When mowing on slopes, empty the optional grass bags when they are half full.

Never operate the shift lever when mowing on a sloped surface.

Never mow a sloped surface when the grass is wet.

Avoid stopping on a sloped surface. If it becomes necessary to stop on a sloped surface, use the following special procedure when restarting the lawn tractor.

Starting on a Sloped Surface

⚠ WARNING

Improper starting on sloped surfaces can cause the lawn tractor to lose traction and tip over.

The lawn tractor can fall on you and cause serious injury or death.

Use the following procedure if you must start the lawn tractor on a sloped surface.

GEAR TRANSMISSION MODELS

1. Press the clutch pedal first, then the brake pedal, all the way down. Move the shift lever to 1st gear.
2. Remove your foot from the clutch pedal, then slowly release the brake pedal.

HYDROSTATIC TRANSMISSION MODEL

1. Press the brake pedal all the way down and hold it there.
2. Release the parking brake.
3. Slowly release the brake pedal while moving the shift lever as required for a safe ground speed.

Obstacles

Use the side of the mower deck to cut close to large obstacles, such as fences or walls.

Be careful when mowing over obstacles embedded in the lawn, such as sprinkler heads, paving, edging, etc. Avoid anything that sticks up above the surface of the lawn.

OPERATION

If a blade hits something, or if any part of the lawn tractor starts to vibrate, stop the engine immediately and check for damage. Striking objects may damage a blade, belt, and/or break the mower deck or other components. Vibration usually indicates serious trouble.

⚠ WARNING

A worn, cracked, or damaged blade can break, and pieces of the damaged blade can become dangerous projectiles.

Thrown objects can cause serious injury.

Inspect the blade regularly, and do not operate the lawn tractor with a worn or damaged blade.

The Distributor's Limited Warranty does not cover parts damaged by accident or collision.

Gravel and Loose Objects

Gravel, loose stones, and landscaping material can be picked up by the lawn tractor and thrown many feet with enough force to cause serious personal injury and/or property damage. The best way to prevent potential injury from thrown objects is to move the PTO clutch lever to **OFF** prior to reaching areas with gravel, loose stones, or landscaping material.

MOWING TIPS

Here are some tips for getting a quality cut with your lawn tractor.

When to Mow

A well-groomed lawn requires mowing at short, regular intervals. During the growing season, a lawn may require mowing twice a week.

Cutting Height

To adjust the height of the mower deck, grip the mower deck height adjustment lever firmly, then slightly lift to clear the notches in the handle guide.

Move the lever outward from the lawn tractor and away from the handle guide. Raise or lower the lever to the desired position.

Move the lever into the position notch, and allow the weight on the lever to lock it onto the handle guide.

To prevent possible damage to the mower deck, always raise it fully when driving the lawn tractor to and from the mowing area; this provides maximum ground clearance.

To avoid damaging or disabling the mower deck height adjustment lever, never attempt to move the lever when the lawn tractor is moving.

A higher cut may be needed to protect the lawn during the summer months. Consult a local nursery or lawn and garden center for advice about specific types of grasses and growing conditions in your area.

Most grasses should be cut when they have grown 1/2 to 1 inch above the recommended height. If your grass grows too tall, cut it back a little at a time, allowing a few days for the grass to recover between mowings. Avoid cutting more than one third of the total grass height in any one mowing.

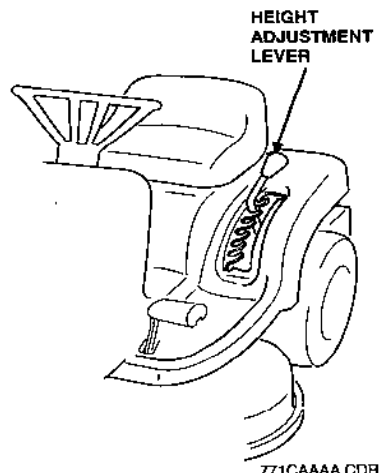

771CAAAA.CDR

OPERATION

Ground Speed

Keep the shift lever in the **MOWING** range for best results. Slow the ground speed of the lawn tractor when mowing taller grass. Always use the shift lever to control the ground speed, never the throttle.

Cutting Width

Allow an adequate amount of overlap in the cutting path when mowing. Four to six inches is recommended; this is roughly the same width as a front tire.

When overlapping in a curve, use a lower speed, and overlap the previous cut by 50%, or about half the width of the mower deck. In extremely tall or thick grass, you may have to cut a larger overlap.

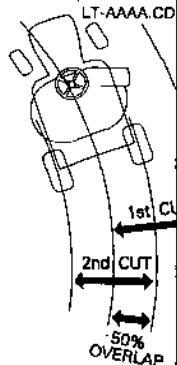
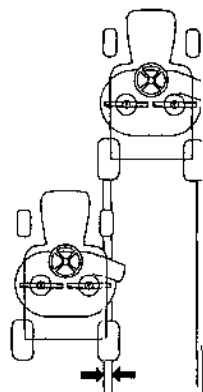

Blade Speed

The blades must spin very fast to cut properly. Always use the **FAST** throttle setting, and keep the engine running at maximum rpm.

If engine speed drops, it could mean the engine is being overloaded by the blade trying to cut too much grass. Mow a narrower swath, operate the lawn tractor at a slower ground speed, or raise the cutting height of the mower deck.

Blade Sharpness

Sharp blades cut cleanly. Dull blades tear grass, leaving shredded ends that turn brown. When the blades don't cut cleanly anymore, have them sharpened or replaced.

Grass and Moisture

Mow when the grass is dry. Mowing wet grass does not produce a neat finish. The inside of the mowing deck or bagging chute may clog when mowing wet grass. Clumps of wet grass will collect on the lawn and can create harmful thatch.

A wet lawn reduces traction and braking performance of your lawn tractor. Further, the tires may leave marks on wet soil softened by moisture. This can detract from the overall appearance.

Fallen Leaves

When equipped with an optional grass bag kit, your lawn tractor can be used to pick up fallen leaves for disposal. Adjust the height of the mower deck as needed to get the best results.

When equipped with an optional mulching kit, you can mulch fallen leaves into your lawn. Don't let the leaf cover get too deep before you begin. For best results, start mulching while grass still shows through the leaf cover. In places where fallen leaves completely cover the grass or leaves begin piling up in front of the mower deck, remove the leaves by raking, or install the optional grass bag kit, so your lawn tractor can pick them up for disposal.

Clogged Mower Deck

Before clearing a clogged mower deck, turn the ignition switch to off. Disconnect the spark plug cap. On mowers equipped with the optional mulch kit, remove the ring pin, side plate, and swirl guide B (see operator's manual supplied with kit).

Clear a clogged deck with a stick, not your hands.

OPERATION

Mowing Patterns

Your Honda lawn tractor will work most efficiently if you use the following mowing patterns as much as possible. Mower deck and equipment design, and the direction in which the blade rotates, cause these mowing patterns to give the best results.

Mulching (optional kit)

Use a counterclockwise mowing pattern. If the lawn has an irregular shape, or many obstacles, divide it into sections where you can use counterclockwise mowing patterns.

Bagging (optional kit)

Use a clockwise mowing pattern. This will give the best bagging performance, leaving the least amount of clippings on the lawn.

Side-discharge Mowing

Start mowing at the outer edges of the lawn, and work toward the center in a circular pattern, always discharging clippings to the outside. This will prevent clippings from piling up in the path of the lawn tractor.

AFTER MOWING

Under most conditions, the lawn tractor accumulates clippings, mud, dirt and other debris on the mower deck and other areas. Frequently, such debris contains moisture, which if allowed to remain on the mower frame, mower deck or other metal parts, can form rust.

Regular cleaning not only helps prevent such rusting, but also makes the lawn tractor operate better. Also, it is much easier to clean these parts when the debris or clippings are fresh rather than stuck on the lawn tractor for days or weeks at a time.

Mower Deck Cleaning

Wash the mower deck only when the lawn tractor is cool. The bearings on the blade pulley shafts expand as they heat up. Cooling rapidly with water can allow moisture to be trapped inside the bearings. This can cause rust to form on the bearing surfaces and shorten bearing life.

Cleaning Other Areas

Certain parts other than the mower deck can accumulate clippings and other debris. When the lawn tractor is cool, you should inspect these areas and brush or wipe off any debris with a soft brush or damp rag. Look around the top of the engine, exhaust area and muffler and by the rear axle near the frame. Do not spray water directly on the engine.

OPERATION

TOWING

An optional rear hitch kit is available from your Honda lawn tractor dealer. This hitch is specifically designed for your lawn tractor. Do not use any other type of hitch on the lawn tractor.

Towing Safety

When the optional hitch is installed and you use a trailer or other attachment, pay attention to these important points for safe operation.

- Avoid sudden starts and stops while towing. The additional weight of a trailer or attachment could cause loss of control resulting in an accident.
- Never allow anyone to ride in or on a trailer or other attachment.
- Failure to use the proper type of trailer or attachment could cause the tractor to overturn resulting in severe personal injury.
- The weight of a trailer or attachment increases stopping distances; use extra care, especially when operating on a slope.
- To avoid loss of control, use extra care when towing a trailer or attachment on a wet or rough surface.
- This lawn tractor is intended for use on relatively flat terrain. Towing a trailer or attachment on a slope exceeding 10 degrees (17% grade) could cause the lawn tractor and/or trailer to tip over.
- Reduce speed when towing on slopes. Use a ground speed in the **MOWING** speed range.
- Avoid sharp turns when towing a trailer or attachment on a slope. If the load in a trailer or attachment is unbalanced, they and/or the lawn tractor may overturn.
- Secure the load in the trailer or attachment before driving. If the load shifts while driving, steering and/or braking can be affected, and in some cases the trailer or attachment and lawn tractor may jackknife.

Towing Weight Limits

Always adhere to the weight limits when towing a trailer or attachment with the lawn tractor.

Maximum Allowable Weight

Maximum allowable weight for the trailer or attachment and any items carried by the trailer or attachment:

On a flat surface..... 500 lbs (227 kg)

On a grade (10 degrees or less)..... 200 lbs (90 kg)

Maximum Tongue Weight

Maximum allowable weight exerted by the trailer or attachment tongue onto the optional rear hitch:

Maximum tongue weight..... 44 lbs (20 kg)

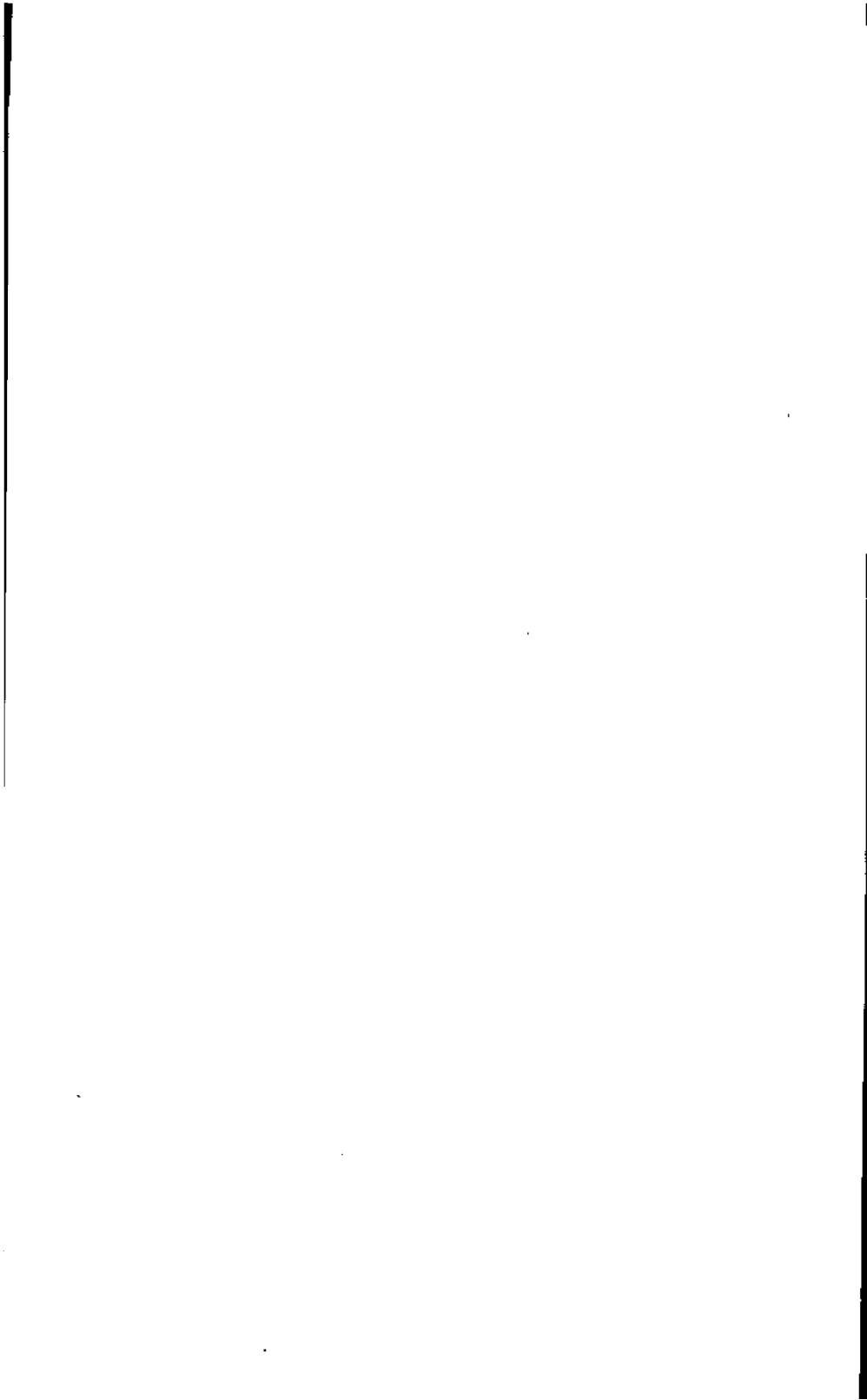

TRANSPORTING

This section explains how to load and transport your lawn tractor safely.

BEFORE LOADING	52
LOADING AND UNLOADING	52

TRANSPORTING

BEFORE LOADING

1. If your lawn tractor is equipped with an optional grass bag kit, remove the bags, hopper cover, lower and upper chute. The rear support arms are bolted directly to the lawn tractor and may remain in place when transporting.
2. If the engine has been running, allow it to cool for at least 15 minutes before loading the lawn tractor. Make sure to turn the fuel valve to **OFF** (page 31).
3. If you need to push the lawn tractor into position, make sure the shift lever is in **NEUTRAL** (gear transmission model) or the transmission release control (hydrostatic transmission model) is in the **RELEASED** position (page 18).

LOADING AND UNLOADING

1. Transport the lawn tractor on a flat, level trailer or truck bed. The tiedown points should be near or on the floor.
2. Securely tie the lawn tractor down, front and rear, with ropes or straps. Use the points shown here when attaching the tiedowns. Do not attach tiedowns to the steering rods.

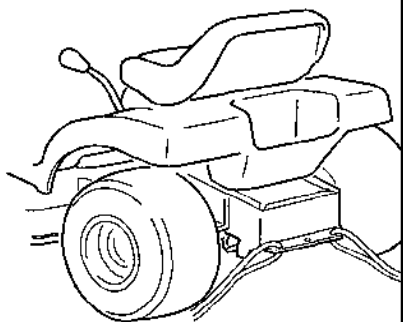
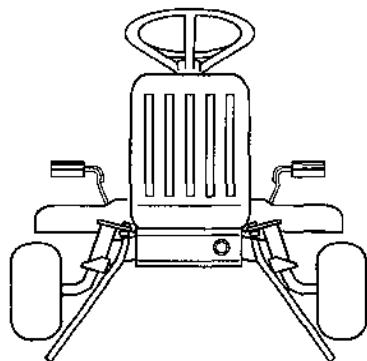

771JAAAA.C0

3. When the lawn tractor is in position, turn the fuel valve **OFF** to reduce the possibility of fuel leaking.
4. The lawn tractor may spill fuel if tilted during loading or transporting. Wipe up spilled fuel immediately.

MAINTENANCE

This chapter explains when and how to perform routine inspection, service, and adjustments for do-it-yourself maintenance. More difficult maintenance tasks should be done by a servicing Honda lawn tractor dealer. This dealer is best equipped and staffed to provide the level of service and safety you and your lawn tractor deserve.

THE IMPORTANCE OF MAINTENANCE	55
MAINTENANCE SAFETY	56
Safety Precautions	56
EMISSION CONTROL SYSTEM	58
Source of Emissions.....	58
The California Clean Air Act	58
Tampering and Altering	58
Problems That May Affect Emissions	58
PROPER MAINTENANCE IS THE OWNER'S RESPONSIBILITY ..	59
Replacement Parts	59
Maintenance.....	59
MAINTENANCE SCHEDULE	60
MAINTENANCE ACCESS POINTS	61
Seat.....	62
Engine Hood.....	63
ENGINE.....	64
Air Cleaner Service.....	64
Engine Oil.....	66
Spark Plug.....	68
FUEL SYSTEM MAINTENANCE	70
Idle Speed Adjustment	70
Fuel Filter Inspection and Replacement.....	71
Carburetor Modification for High Altitude Operation.....	72
Fuel Recommendations.....	73
ELECTRICAL	74
Battery Service	74
Fuse Replacement	76
BRAKE	77
Brake Pedal Freeplay Inspection.....	77
Brake Pedal Freeplay Adjustment (gear transmission model)	78
Brake Wear Inspection (gear transmission model)	78
MOWER DECK	79
Adjusting the Anti-scalp Rollers	79
Removing the Mower Deck.....	80

MAINTENANCE

BLADES	84
Blade Inspection.....	84
Blade Installation.....	88
MOWER DECK LEVEL INSPECTION AND ADJUSTMENT	89
Preparation.....	89
BELTS	92
Blade Belt.....	92
Drive Belt.....	96
TIRES AND WHEELS	97
Jack Points.....	97
Front Wheels.....	98
Rear Wheels.....	99
OTHER ITEMS	100
Hydrostatic Fluid Reservoir (hydrostatic transmission model).....	100
Clutch Pedal Freeplay (gear transmission model).....	100
Lubrication Points.....	102

THE IMPORTANCE OF MAINTENANCE

Good maintenance is essential for safe, economical, and trouble-free operation. It will also help reduce air pollution.

To help you properly care for your lawn tractor, the following pages include a maintenance schedule, routine inspection procedures, and simple maintenance procedures using basic hand tools. Other service tasks that are more difficult, or require special tools, are best handled by professionals and are normally performed by a Honda technician or other qualified mechanic.

The maintenance schedule applies to normal operating conditions. If you operate your lawn tractor under unusual conditions, consult your servicing dealer for recommendations applicable to your individual needs and use.

WARNING

Improper maintenance, or failure to correct a problem before operation, can cause a malfunction in which you can be seriously hurt or killed.

Always follow the inspection and maintenance recommendations and schedules in this owner's manual.

MAINTENANCE

MAINTENANCE SAFETY

Some of the most important safety precautions follow. However, we cannot warn you of every conceivable hazard that can arise in performing maintenance. Only you can decide whether or not you should perform a given task.

WARNING

Failure to properly follow maintenance instructions and precautions can cause you to be seriously hurt or killed.

Always follow the procedures and precautions in the owner's manual.

Safety Precautions

- Make sure the engine is off before you begin any maintenance or repairs. This will eliminate several potential hazards:
 - **Carbon monoxide poisoning from engine exhaust.**
Be sure there is adequate ventilation whenever you operate the engine.
 - **Burns from hot parts.**
Let the engine and exhaust system cool before touching.
 - **Injury from moving parts.**
Do not run the engine unless instructed to do so.

- Read the instructions before you begin, and make sure you have the tools and skills required.
- To reduce the possibility of fire or explosion, be careful when working around gasoline. Use only a nonflammable solvent, not gasoline, to clean parts. Keep cigarettes, sparks, and flames away from all fuel-related parts.
- For certain operations, the lawn tractor must be raised off the ground. Be sure the lawn tractor is solidly supported before you put any part of your body under the lawn tractor.
- Disconnect the spark plug cap and wear heavy gloves when working near the mower deck, belts, or blades.
- Never support or stand the lawn tractor on either side or end. Fuel, oil, or battery electrolyte can leak out.

Remember that your servicing dealer knows your lawn tractor best and is fully equipped to maintain and repair it.

To ensure the best quality and reliability, use only new, genuine Honda parts or their equivalents for repair and replacement.

MAINTENANCE

EMISSION CONTROL SYSTEM

Source of Emissions

The combustion process produces carbon monoxide, oxides of nitrogen, and hydrocarbons. Control of hydrocarbons and oxides of nitrogen is very important because, under certain conditions, they react to form photochemical smog when subjected to sunlight. Carbon monoxide does not react in the same way, but it is toxic.

The California Clean Air Act

California regulations require all manufacturers to furnish written instruction describing the operation and maintenance of emission control systems.

The following instructions and procedures must be followed in order to keep the Honda engine emissions within the emission standards.

Tampering and Altering

Tampering with or altering the emission control system may increase emissions beyond the legal limit. Among those acts that constitute tampering are:

- Removal or alteration of any part of the intake, fuel, or exhaust systems.
- Altering or defeating the governor linkage or speed-adjusting mechanism to cause the engine to operate outside its design parameters.

Problems That May Affect Emissions

If you are aware of any of the following symptoms, have your engine inspected and repaired by your authorized Honda servicing dealer.

- Hard starting or stalling after starting.
- Rough idle.
- Misfiring or backfiring under load.
- Afterburning (backfiring).
- Black exhaust smoke or high fuel consumption.

PROPER MAINTENANCE IS THE OWNER'S RESPONSIBILITY

Replacement Parts

The emission control systems on your new Honda engine were designed, built, and certified to conform with California emission regulations. Honda recommends only the use of new, genuine Honda parts or their equivalent. The use of other replacement parts which are not of equivalent quality may impair the effectiveness of your emission control system.

Maintenance

Follow the Maintenance Schedule on page 60. Remember that this schedule is based on the assumption that your machine will be used for its designed purpose. Sustained high-load or high-temperature operation, or use in unusually wet or dusty conditions, will require more frequent service.

MAINTENANCE

MAINTENANCE SCHEDULE

	Item	Action	Service Interval hours (months) (whichever comes first)					Page
			each use	first 20 (3)	50 (6)	100 (12)	300 (36)	
●	Engine oil	check	○					66
		change		○		○		66
●	Air filter elements	check	○					64
		clean			○ ¹			64
		replace					○ ²	64
	Cooling air intake & muffler	check	○					25
	Hydrostatic fluid	check level	○ ³					100
	Muffler area	check	○					23
	Cooling fan screen	check	○					25
	Battery electrolyte	check level	○					74
	Tires & air pressure	check	○					97
	Mower deck belt	check	○					92
	Drive belt	check	○					96
	Brake pedal	check	○					77
	Blade condition	check	○					84
	Blade bolts	inspect	○					85
	Blade bolts	check tightness		○ ⁴	○ ⁴			85
	Brake pedal freeplay	check & adjust	○ ⁵					77
	Front & rear axle grease	one pump			○			102
	Parking brake	check	○					17
●	Spark plug	check & clean				○		68
		replace					○	68
	Optional spark arrester	clean				○		128
	Clutch pedal freeplay	check & adjust	○					100
●	Idle speed	check & adjust					○	70
	Throttle cable	check & adjust			○			Shop Manual
●	Fuel tank and filter	check				○ ⁴		71
●	Fuel line	replace					○ ⁴	Shop Manual
●	Valve clearance	check & adjust					○ ⁴	Shop Manual
	Wheel grease	one pump			○			102
	Engine cooling fins & shroud	clean					○ ⁴	25

● Emission-related items

- 1 Service every 10 hours or daily when used in dusty areas.
- 2 Replace paper filter element only
- 3 Hydrostatic transmission model only.
- 4 These items should only be serviced by an authorized Honda servicing lawn tractor dealer unless you are mechanically proficient and have the proper tools.
- 5 Gear transmission model only

MAINTENANCE ACCESS POINTS

Refer to the illustrations on this page for the locations of specific maintenance items and service points.

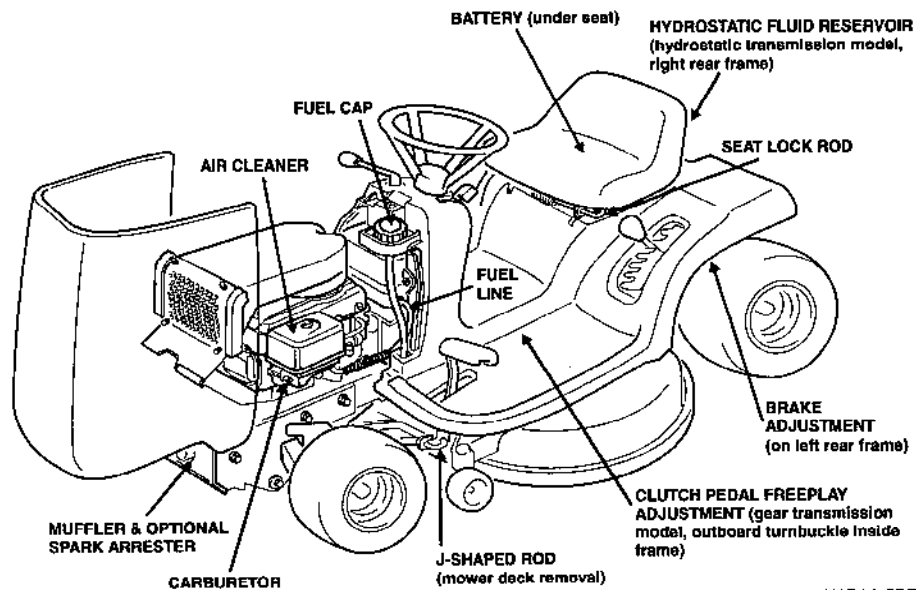

771NADAA.CDR

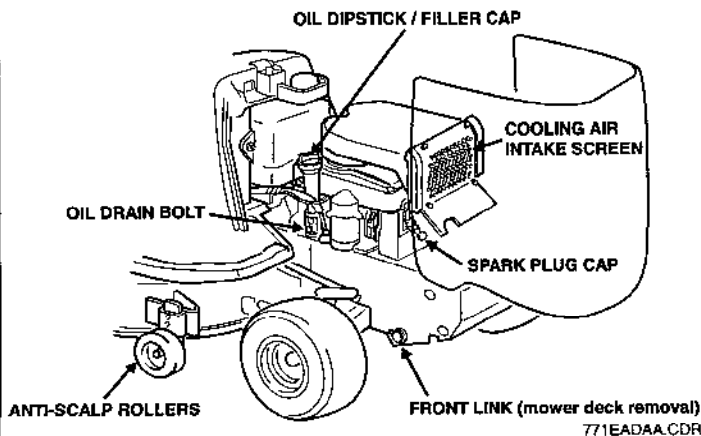

771EADAA.CDR

MAINTENANCE

Seat

To access the battery compartment or to adjust the seat position, you must raise and lock the seat.

Raising and Locking the Seat

On the left side of the lawn tractor, just below the seat cushion, there is a spring loaded seat lock rod. Pull the pin outward and away from the seat, then raise the seat up.

With the seat in the fully raised position, let the pin slide back toward the seat bracket and lock the seat in the up position.

Press down on the seat to make sure it is locked in the upright position.

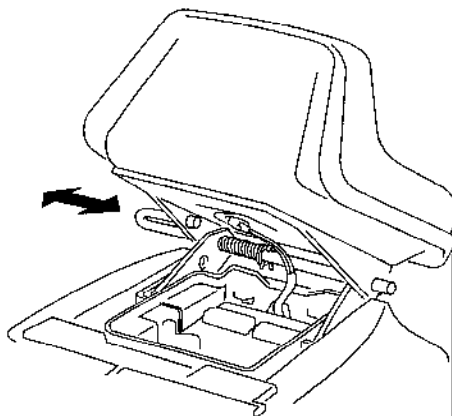

772KABAA.CDI

Adjusting the Seat Position

1. Loosen the four hex bolts used to attach the seat to the seat bracket.
2. Move the seat to obtain the desired front to rear position.
3. Securely tighten the four hex bolts, then lower and lock the seat.

Lowering and Locking the Seat

1. To lower the seat, slightly move the seat upward, to take pressure off the locking pin.
2. While grasping the seat with one hand, use your other hand to pull the locking pin away from the seat bracket.
3. Lower the seat all the way down, then release the locking pin, so it locks into the hole on the side of the seat bracket. Verify that the seat is locked down by trying to lift the seat.

Engine Hood

The engine hood must be raised to perform some maintenance procedures on the lawn tractor.

Raising the Engine Hood

1. Near the base of the steering wheel is a recess between the body and engine hood. Grab the engine hood only at this point, then pull it up and forward until it stops.
2. The engine hood does not lock in the open position, so be careful not to bump or knock it when it is open.

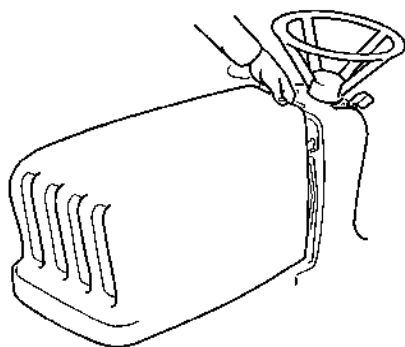

771KAAAA.CDR

Lowering the Engine Hood

1. Carefully lower the engine hood; don't let it drop and slam into the lawn tractor body.
2. When the engine hood is resting, press it down firmly.

MAINTENANCE

ENGINE

With the engine hood open, there are a number of items available for inspection and service.

Air Cleaner Service

Check that the air filter elements are clean and in good condition. Dirty air filter elements restrict air flow to the engine, reducing performance. Damaged air filter elements allows dirt to enter the engine, causing rapid engine wear.

1. The air filter is located on the left rear side of the engine. Remove the wing nut from the top of the air cleaner cover.
2. The air filter assembly has two parts. The outer foam element covers the paper element and can be removed.
3. If the foam element appears clean over more than half its surface, it does not need cleaning. Reinstall the air cleaner housing cover. If the foam element appears dirty, continue to the next step.

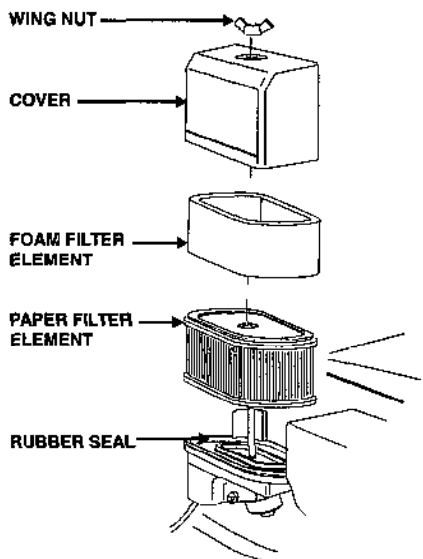

772FAAAA.CDR

NOTICE

Operating the engine with no air filter or with damaged air filter elements can cause rapid engine wear.

4. Clean the outer foam element of any debris. Remove the air filter. Separate the foam element from the paper element, and carefully check for holes or tears. Replace any damaged element(s).
5. Clean the foam element by squeezing it in warm soapy water, rinsing it, and allowing it to dry. You may also use a nonflammable solvent and then allow it to dry.

6. Oil the foam element by dipping it in clean engine oil and squeezing out all excess oil. If too much oil is left in the foam, the engine may smoke when started.
7. Clean the paper element by tapping it on a hard surface to knock off dirt or by blowing compressed air not exceeding 30 psi (207 kPa) through the element from the inside. Never try to brush off the dirt, as that just forces it into the paper filter fibers.
8. Use a damp rag to wipe any dirt from the inside of the air cleaner housing and cover. Be careful not to allow dirt into the duct leading to the carburetor. Be sure the rubber seal in the base is in place and in good condition.
9. Place the foam element over the paper element, and install the filter in the air cleaner housing.
10. Reinstall the air cleaner housing cover and wing nut.

MAINTENANCE

Engine Oil

Engine oil capacity: 1.16 US quarts (1.1 ℓ)

Recommended Oil

Use a 4-stroke motor oil that meets or exceeds the requirements for API service classification SF, SG, or equivalent. Always check the API SERVICE label on the oil container to be sure it includes the letters SF, SG, or equivalent.

SAE 10W-30 is recommended for general use. Other viscosities shown in the chart may be used when the average temperature in your area is within the indicated range.

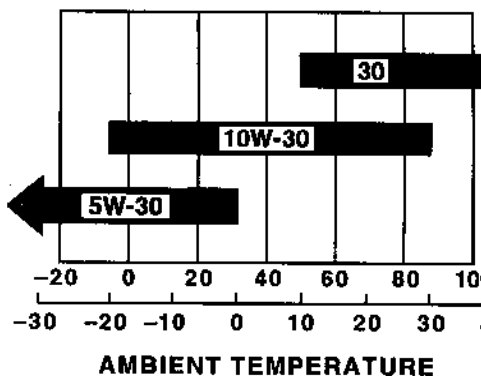

LM-AAJA

NOTICE

Using nondetergent oil can shorten the engine's service life, and using 2-stroke oil can damage the engine.

Changing the Oil

Change the oil at the recommended interval (page 60) or more frequently under extreme operating conditions.

Drain the oil while the engine is warm to assure rapid and complete draining.

1. Raise the engine hood.
2. Clean the area around the oil filler cap and unscrew it.
3. Near the bottom of the oil filler tube is the oil drain bolt. Position a suitable oil collection container that can hold at least 2 US quarts (2.2 ℓ) below the oil drain bolt.
4. Remove the drain bolt and allow the engine oil to drain out.
5. Once the used oil has drained, install the oil drain bolt and tighten securely.

6. Fill the engine with the correct amount of the recommended oil through the oil filler tube. Do not overfill; measure the oil level as shown on page 21. Replace the oil filler cap.
7. Verify that there is no oil leaking from the drain bolt.
8. Please dispose of used motor oil and the oil containers in a manner that is compatible with the environment. We suggest you take it in a sealed container to your local recycling center or service station for reclamation. Do not throw it in the trash or pour it on the ground or down a drain.

MAINTENANCE

Spark Plug

Recommended Types

NGK: BPR5ES ND: W16EPR-U

NOTICE

Spark plugs of the wrong size or incorrect heat range can cause engine damage.

Removal, Inspection and Replacement

For good performance, the spark plug should have the correct gap and be free of deposits.

1. Raise the engine hood, then disconnect the spark plug cap, and remove any dirt from around the spark plug area.
2. Remove the spark plug.
3. Inspect the spark plug for excessively worn electrodes, chips or cracks in the insulator, or excessive deposits. Replace the spark plug if you have any doubts about its condition.
4. Measure the electrode gap with a wire gap gauge. Adjust the gap to 0.028 - 0.031 inch (0.7 - 0.8 mm) by bending the side electrode with a proper spark plug tool.

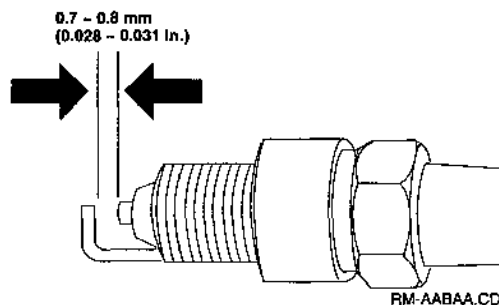

5. Install the spark plug carefully, by hand, to avoid cross-threading. Use a spark plug wrench to tighten the plug enough to compress the washer. For a used plug, tighten $1/8$ to $1/4$ of a turn after the spark plug seats. For a new plug, tighten $1/2$ turn after the spark plug seats.

NOTICE

A loose spark plug can become hot enough to damage the engine. Overtightening a spark plug can damage the threads in the engine.

6. Reconnect the spark plug cap.

MAINTENANCE

FUEL SYSTEM MAINTENANCE

Idle Speed Adjustment

Perform this adjustment if the idle is slow or rough, and you're sure the air filter and spark plug are in good condition. You must have an accurate tachometer to properly measure engine speed.

1. Start the engine in an area with adequate ventilation to avoid carbon monoxide poisoning. Allow the engine to warm to normal operating temperature.
2. With the throttle on **SLOW**, turn the throttle stop screw in or out to obtain the specified idle speed.

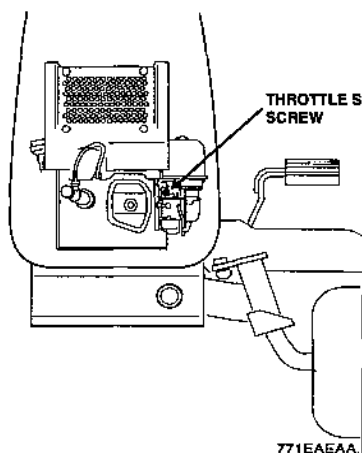

Standard idle speed: 1,750 +200/-0 rpm

Fuel Filter Inspection and Replacement

We suggest you perform this procedure when the fuel tank is nearly empty.

1. Raise the engine hood. Locate the carburetor on the left side of the engine. Move the fuel valve to **ON** (page 14). Locate the drain screw on the back side of the carburetor.
2. Drain fuel into an approved container by loosening the drain screw.

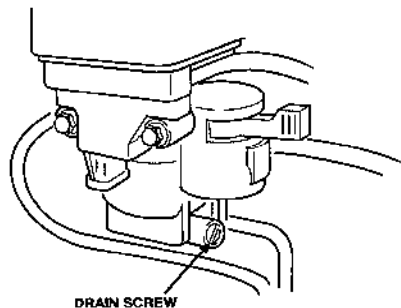

771FABAA.COR

⚠ WARNING

Gasoline is highly flammable and explosive. You can be burned or seriously injured when handling fuel.

- Stop the engine and keep heat, sparks, and flame away.
- Handle fuel only outdoors.
- Wipe up spills immediately.

3. Locate the fuel supply line between the carburetor and fuel tank. Loosen the hose clamp where the fuel supply line connects to the fuel tank, and disconnect the fuel line from the tank.
4. The fuel filter is a white plastic piece inside the fuel tank outlet fitting. Note how the fuel filter is installed when you remove it from the fuel line.
5. Install a new fuel filter, then properly dispose of the old filter and any spilled fuel.

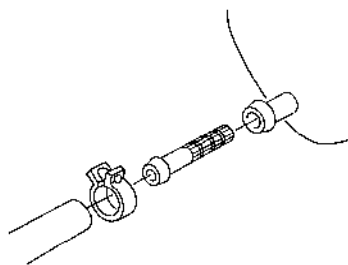

772FAEAA.

Carburetor Modification for High Altitude Operation

At high altitude, the standard carburetor air-fuel mixture will be too rich. Performance will decrease, and fuel consumption will increase. A very rich mixture will also foul the spark plug and cause hard starting.

High altitude performance can be improved by a specific modification to the carburetor. If you always operate your lawn tractor at altitudes above 6,000 feet (1,800 meters) have an authorized Honda lawn tractor dealer perform this carburetor modification.

Even with carburetor modification, engine horsepower will decrease about 3.5% for each 1,000-foot (300-meter) increase in altitude. The effect of altitude on horsepower will be greater than this if no carburetor modification is made.

NOTICE

When the carburetor has been modified for high altitude operation, the air-fuel mixture will be too lean for low altitude use. Operation at altitudes below 6,000 feet (1,800 meters) with a modified carburetor may cause the engine to overheat and result in serious engine damage. For use at low altitudes, have an authorized Honda lawn tractor dealer return the carburetor to original factory specification.

Fuel Recommendations

Use unleaded gasoline with a pump octane rating of 86 or higher.

This engine is certified to operate on unleaded gasoline. Unleaded gasoline produces fewer engine and spark plug deposits and extends exhaust system life.

Never use stale or contaminated gasoline or an oil/gasoline mixture. Avoid getting dirt or water in the fuel tank.

Occasionally you may hear light "spark knock" or "pinging" (metallic rapping noise) while operating under heavy loads. This is no cause for concern.

If spark knock or pinging occurs at a steady engine speed, under normal load, change brands of gasoline. If spark knock or pinging persists, see an authorized Honda lawn tractor dealer.

NOTICE

Running the engine with persistent spark knock or pinging can cause engine damage.

Running the engine with persistent spark knock or pinging is misuse, and the Distributor's Limited Warranty does not cover parts damaged by misuse.

For oxygenated fuel information refer to page 127.

MAINTENANCE

ELECTRICAL

Battery Service

Your lawn tractor charging system charges the battery while the engine is running. However, if the lawn tractor is only used periodically, the battery must be charged monthly to maintain the battery service life.

A lead-acid battery self-discharges at a rate of 0.5 - 1.0 % per day. If the lawn tractor is not operated for a month, the battery can discharge as much as 30%. This could cause the engine not to start or shorten the service life of the battery.

WARNING

The battery contains sulfuric acid (electrolyte) which is highly corrosive and poisonous.

Getting electrolyte in your eyes or on your skin can cause serious burns.

Wear protective clothing and eye protection when working near the battery.

EMERGENCY PROCEDURES:

Eyes — Flush with water from a cup or other container for at least 15 minutes (water under pressure can damage the eye). Immediately call a physician, local poison control, or 911.

Skin — Remove contaminated clothing. Flush the skin with large quantities of water. Call a physician immediately.

Swallowing — Drink water or milk. Call your local poison control or a physician immediately.

Inspection

1. Raise and lock the seat. Remove the battery cell caps.
2. Inspect the electrolyte level of each cell. The electrolyte liquid should cover all the plates.
3. If any plates are not covered, add distilled water as necessary.

Removal

To charge the battery, follow the procedures below.

1. Raise and lock the seat. Remove the negative (-) cable from the battery negative (-) terminal, then remove the positive (+) cable from the battery positive (+) terminal.
2. Remove the battery from the battery compartment.

Charging

1. Remove the battery cell caps.
2. Connect the battery charger following the manufacturer's instructions. After charging, check the electrolyte level in each of the cells. Add distilled water if needed, then install the battery caps.
3. Clean the outside of the battery and the battery compartment with a solution of baking soda and water. Don't allow any of the solution to drip down the vent caps into the battery cells.

⚠ WARNING

The battery gives off explosive hydrogen gas during normal operation.

A spark or flame can cause the battery to explode with enough force to kill or seriously injure you.

Keep flame and sparks away. Wear protective clothing and a face shield, or have a skilled mechanic do battery maintenance.

MAINTENANCE

Installation

1. With the seat raised and locked, install the battery in the compartment. The battery terminals should face the rear.
2. Install the positive (+) cable on the battery positive (+) terminal; then install the negative (-) cable on the battery negative (-) terminal, then lower and lock the seat.

Fuse Replacement

The fuse and fuse holder are next to the positive (+) connector near the battery. The lawn tractor will not start if the fuse is blown. To replace the fuse:

1. Turn the ignition switch to **OFF**, then raise and lock the seat.
2. The fuse used in the lawn tractor is a blade type. Grip the edge of the fuse with one hand and the fuse holder with the other. Pull the fuse straight out of the holder.

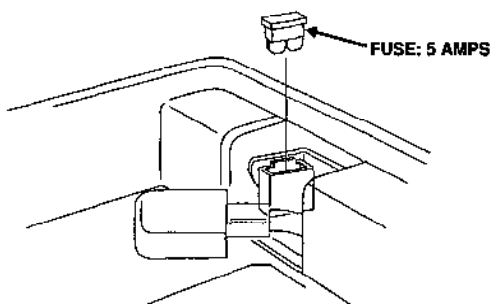

3. An open (blown) fuse is indicated by a broken link, visible between the two blades on the fuse. Discard an open fuse, and replace it with one of the same rating (5 amps).
4. If replacement fuses continue to open, determine the cause, and correct the problem before operating the lawn tractor further.

772MAAAA.CDR

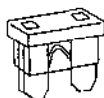

GOOD

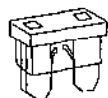

OPEN

771MAAAA.CDR

NOTICE

Never use a fuse with a different rating from that specified. Serious damage to the electrical system or fire may result.

BRAKE

Before performing any maintenance on the brake system, park the lawn tractor on a flat, level surface. Release the parking brake, remove the ignition key and disconnect the spark plug cap.

Brake Pedal Freeplay Inspection

Gear Transmission Model

1. Place a ruler along the brake pedal arm. Get a helper to hold the clutch pedal all the way down.
2. Press the brake pedal down, and note a strong resistance. Measure the brake pedal arm travel.
3. Brake pedal arm travel from rest to the point of strong resistance should be $1\text{-}1/4 \sim 1\text{-}13/16$ inch ($32 \sim 46$ mm). Adjust if freeplay exceeds $1\text{-}13/16$ inch (46 mm).

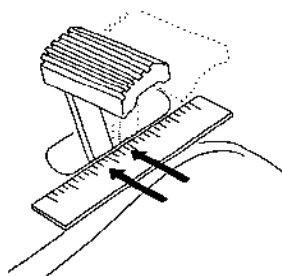

772CAIAB.CDR

Hydrostatic Transmission Model

1. Move the shift lever to **NEUTRAL**.
2. Place a ruler along the brake pedal arm. Press the brake pedal down and note a resistance. Measure the brake pedal arm travel.
3. Brake pedal arm travel from rest to the point of strong resistance should be $1\text{-}13/16 \sim 2\text{-}5/32$ inch ($46 \sim 55$ mm). If the measurement is greater than $2\text{-}5/32$ inch (55 mm), the brake pedal freeplay must be adjusted.

Brake pedal freeplay adjustment on the hydrostatic transmission model requires precision measuring of the brake pad wear with special tools. See the *H2013 Shop Manual* or an authorized servicing Honda lawn tractor dealer.

MAINTENANCE

Brake Pedal Freeplay Adjustment (gear transmission model)

1. Locate the brake assembly and adjustment nut, located outside the left rear side of the frame.
2. Tighten the adjustment nut until resistance is felt, then turn it back $3/4$ turn. Adjust so freeplay is $1 - 1/4 \sim 1 - 3/4$ inch ($32 \sim 36$ mm).
3. Take care not to overtighten the adjustment nut.

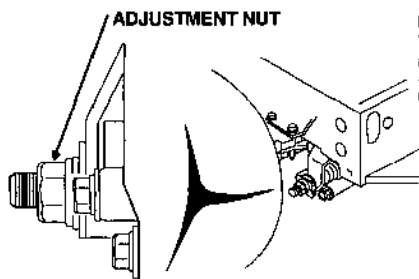

771RAAAA.CD

Brake Wear Inspection (gear transmission model)

Brake wear is determined by measuring the amount of exposed threads between the reference point (a plastic ring) and the adjustment nut. If the visible threads measure about the thickness of a dime (1 mm), the brake pads have exceeded their service life and must be replaced.

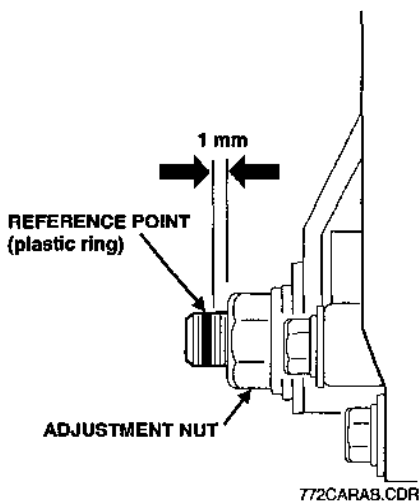

772CARAB.CDR

MOWER DECK

Use this section to adjust the anti-scalp rollers, and to remove, adjust and install the mower deck.

Adjusting the Anti-scalp Rollers

The two anti-scalp roller wheels help prevent the mower blades from gouging or scalping high spots on the lawn. The mower deck is designed to float across the lawn, and it is important to set the anti-scalp rollers correctly. The setting depends on the type of lawn being mowed and the mower deck height.

For flat terrain, use the lower hole in the anti-scalp roller shaft. Align the hole with the hole in the mower deck that corresponds to the selected cutting height, as shown.

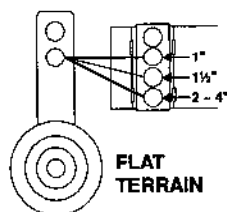

FLAT
TERRAIN

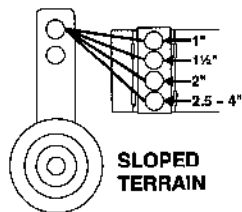

SLOPED
TERRAIN

7711AAAA.CDR

For sloped or uneven terrain, use the upper hole in the anti-scalp roller shaft. Align the hole with the hole in the mower deck that corresponds to the selected cutting height, as shown.

MAINTENANCE

Removing the Mower Deck

1. Place the lawn tractor on a solid, level surface.
2. Engage the parking brake, put the shift lever in **NEUTRAL** and move the PTO lever to **OFF**.
3. Disconnect the spark plug cap, and remove the ignition key to prevent accidental starting.
4. If the optional grass bag kit is installed, refer to the operator's manual for the grass bag kit, and remove the lower chute from the mower deck.
5. Position the front wheels straight ahead. Lower the mower deck all the way down.
6. To remove the mower deck, you will need heavy gloves and two 2" x 4" boards or the equivalent.
7. From the right side of the mower deck, locate the PTO clutch arm and belt tensioner arm. The clutch arm is part of the tractor, while the tensioner arm is on the mower deck. Remove the 10 mm spring clip and two flat washers from the connecting rod.
8. Raise the mower deck all the way up. Put on heavy gloves.

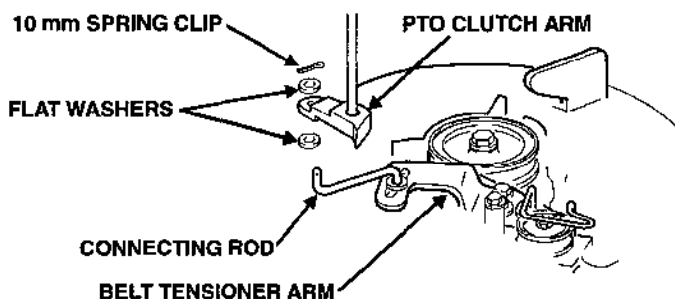

771DAAAA.CDR

9. Place two 2" x 4" boards (or equivalent) under the left and right sides of the mower deck. Lower the mower deck, so it is resting solidly on the two boards.

10. On the right outside of the frame (near the engine crankshaft pulley) locate a single, silver-colored bolt that holds the blade belt guard in place. Loosen, but don't remove the bolt.

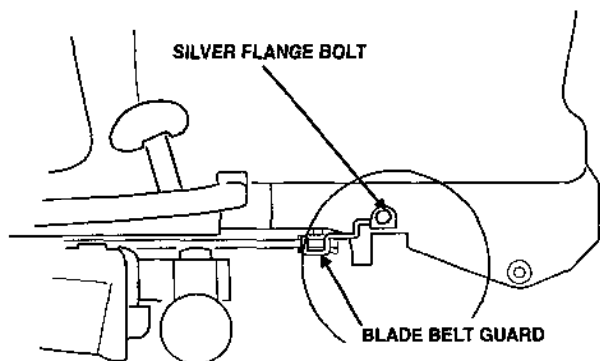

11. Move the blade belt guard up and away from the pulley, while pulling the blade belt off the engine crankshaft pulley.
12. Locate the center section of the two rear links, where the mower deck rear brackets are attached. Remove a 14 mm spring clip and flat washer from each side.

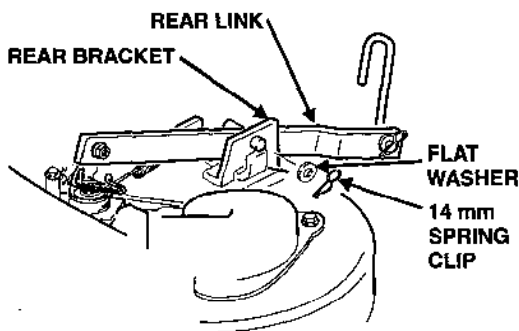

13. Move the mower deck and rear links as needed to push the pins (on the rear links) clear of the rear brackets. Raise the height adjustment lever all the way up, so the links are clear of the mower deck.

MAINTENANCE

14. Locate the J-shaped rod that connects the front links to the front mower deck brackets. From the left side of the mower deck, remove the spring clip from the rod, then remove the rod.

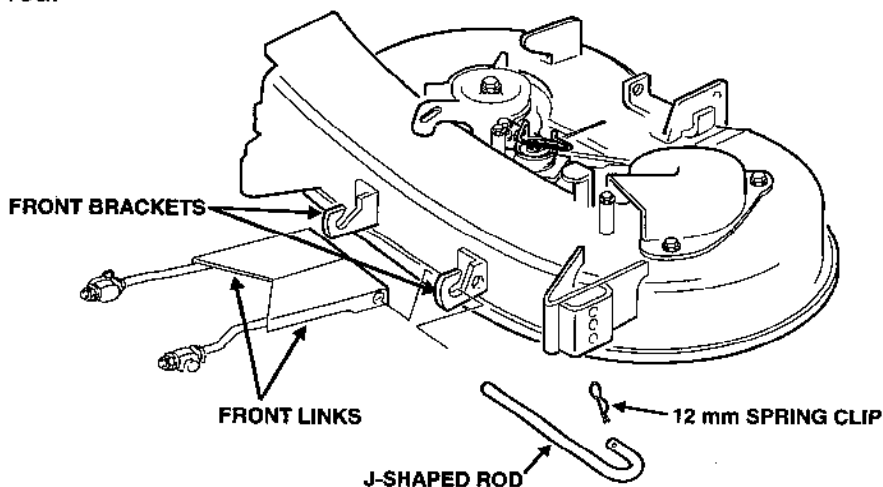

771DADAA.CDR

15. Push the mower deck back slightly, so the front links fall clear. Turn the steering wheel all the way to the left. Pull the mower deck out from the right side.

If you wish to use the lawn tractor with the mower deck removed, remove the two front links, washers and spring clips. Make sure the height adjustment lever is raised all the way up.

Installation of the mower deck is similar to removal, with a few points to keep in mind:

- It is helpful to install the J-shaped rod into the holes on the front links first. The J-shaped rod and links can be installed by using the slots on the front mower deck brackets.

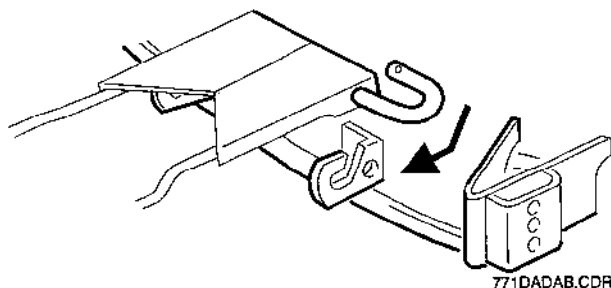

- Make sure the two front links install in the *inside* of the front mower deck brackets.
- Make sure the J-shaped rod is fully seated as shown. Don't forget to install the spring clip back onto the J-shaped rod.

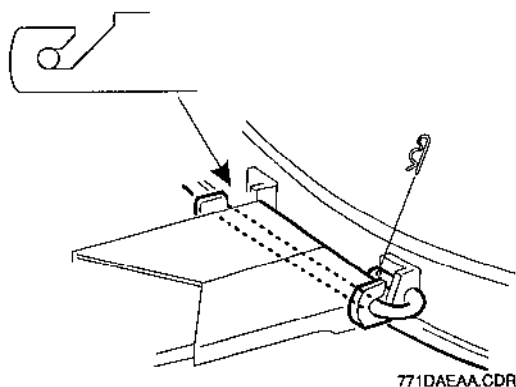

- Recheck the leveling of the mower deck (page 89 after it is installed).

MAINTENANCE

BLADES

Inspect, check bolt tightness, remove, sharpen, and replace the blades as described in this section. Always complete these steps before working around the mower blades:

1. Move the PTO clutch lever to **OFF**. Engage the parking brake.
2. Turn the ignition switch to **OFF** and remove the key.
3. Disconnect the spark plug cap.

Blade Inspection

When the blades need resharpening or replacement, take the lawn tractor to an authorized servicing Honda lawn tractor dealer. Or, if you have a torque wrench, you can remove and install the blades yourself, as described later in this chapter.

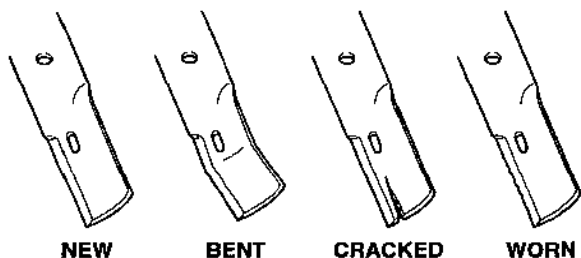

CM-ABAAA.CDR

⚠ WARNING

A worn, cracked, or damaged blade can break and pieces of the blade can become dangerous projectiles.

Thrown objects can cause serious injury.

Inspect the blades regularly and do not operate the lawn tractor with a worn or damaged blade.

Inspecting For A Bent Blade

Perform this inspection prior to attempting any mower deck leveling adjustments.

1. Wearing heavy gloves, position the right (discharge) side blade so it is parallel to the front axle.
2. Measure the height of the right side blade at point B and record this measurement.
3. Rotate the right side blade 180 degrees and measure the other tip at point B.
4. The two measurements should be the same; if they are not, the blade or blade spindle may be bent.
5. Repeat steps 1 - 4 for the left side blade but measure at point A.

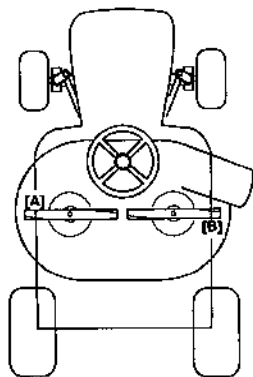

7718AAAA.CDR

Blade Bolt Tightness

Blade bolt tightness should be checked as specified in the Maintenance Schedule (page 60).

⚠ WARNING

The blades are sharp, and spin at high speed.

A spinning blade can cut you severely and can amputate fingers and toes.

- Wear protective footwear.
- Keep your hands and feet away from the mower deck while the engine is running.
- Stop the engine before performing any adjustment, inspection, or maintenance.

MAINTENANCE

1. Remove the mower deck from the lawn tractor; see page 80.
2. Put on heavy gloves and turn the mower deck upside down.
3. Wearing heavy gloves, clean the dirt and grass from the blades and the inside of the mower deck.
4. Hold each blade firmly, or block it with a piece of wood, and use a torque wrench to check bolt torque on the blade bolts.

Blade bolts tightening torque: 43.4 ft-lb (60 N.m)

Blade Removal

Before attempting to remove and install a blade, be sure you have the proper tools and equipment, including a torque wrench to tighten the blade bolt and heavy gloves to protect your hands from the blade.

1. Remove the mower deck from the lawn tractor; (see page 80).
2. Block movement of the blade with a block of wood.
3. Put on heavy gloves; loosen the blade bolt and special washer.
4. Note how the cone-shaped washer is aligned on the pulley shaft. The side marked **INSIDE** goes toward the blade.
5. Remove the blade and blade holder.

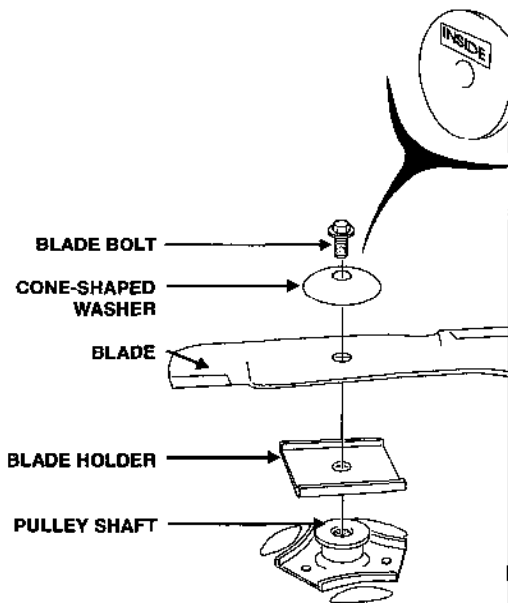

772BADAC.C

Blade Sharpening

A dull blade may be sharpened, but a blade that is worn out, bent, cracked, or otherwise damaged must be replaced. Always use a genuine Honda replacement blade or high-quality equivalent.

SHARPENING GUIDELINES

- Maintain the original angle of the blade (about 30°).
- Sharpen the blades to a knife edge.

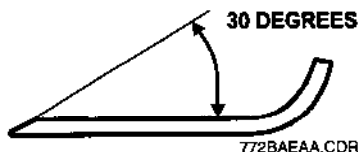

- Remove an equal amount of material from each end of the blade to maintain balance.

- Do not remove material from the inner area of the cutting edge. If you need to remove material to restore the cutting edge, taper the edge toward the tip. Do not taper beyond 1/3 of the blade width.
- Do not grind the back side of the blade
- Check the balance of the blade by placing a dowel through the center hole. Should one end of the blade drop, remove additional material from that end of the blade to achieve balance.

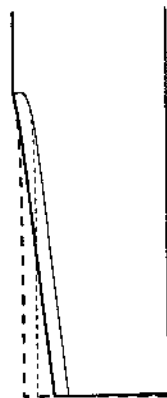

MAINTENANCE

Blade Installation

Use a genuine Honda replacement blade or high quality equivalent.

1. Clean any dirt and grass from around the blade shaft and inside the deck.
2. Install the blade with the upturned edges of the blade toward the mower deck. Note the right side blade has a more pronounced lift angle. The right side high-lift blade must be installed on the right side spindle. When using the optional mulching kit, the two mulching blades are identical and may be installed on either spindle.

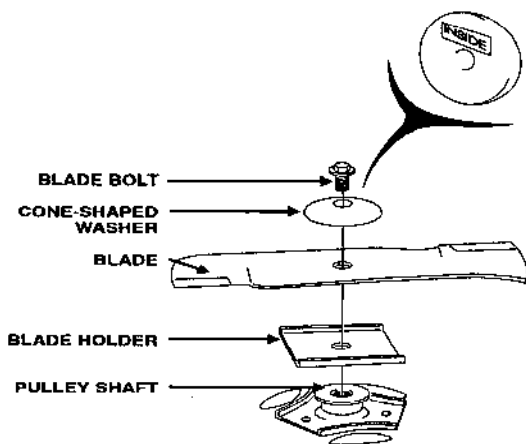

772BADAC.CDR

3. Install the washer with the side marked **INSIDE** facing the blade.
4. The blade bolt and washer are specific to this application and must not be replaced with any other bolt or washer.
5. Be sure to properly align the blade and blade holder square on the spindle as shown.
6. Hold the blade firmly, and use a torque wrench to check that the blade bolt is properly tightened.

Blade bolt tightening torque: 43.4 ft-lb (60 N·m)

MOWER DECK LEVEL INSPECTION AND ADJUSTMENT

For the best cut quality, the mower deck must sit at a proper angle to the ground. There are two adjustments that can be made to the mower deck.

- Left to right mower deck leveling adjustment
- Front to rear mower deck adjustment

Preparation

All adjustments should only be performed after the following steps have been completed:

1. Park the lawn tractor on a smooth, flat, level surface.
2. Move the PTO lever to **OFF**.
3. Set the parking brake **ON**.
4. Disconnect the spark plug cap, and remove the ignition key.
5. Verify correct tire pressure. See page 97.
6. Inspect for bent blades. See page 85.
7. Remove the lower chute from grass bag (optional kit) equipped models.
8. The J-shaped cross rod must be fully installed in front mower deck bracket slots. Reposition the rod or deck to eliminate any gap.

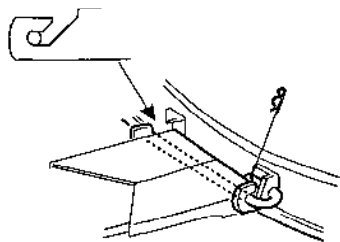

771DAEAA.CDR

MAINTENANCE

Left-To-Right Leveling

INSPECTION

1. Prepare the lawn tractor as previously outlined.
2. Set the height adjustment lever to the number 3 position. Make sure the anti-scalp rollers do not touch the ground. Put on heavy gloves, as you need to rotate the blades.
3. Rotate the blades, so they are parallel to the front axle. Measure the height of the blade tip at points A and B as shown. B should be 0 ~ 3/16 inch (0 ~ 5 mm) higher than A.
4. If B measures more than 3/16 inch (5 mm) higher, or is lower than A, you'll need to adjust the right side height of the mower deck.

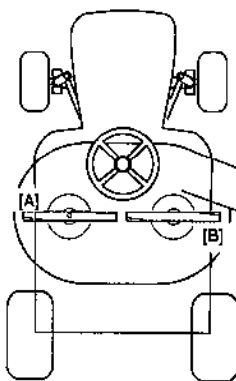

771BAAAA.C

ADJUSTMENT

1. Locate the right rear lift rod, where the deck is attached to the rear of the lawn tractor frame. The threaded section of the rod allows the position of the mower deck connecting link to be adjusted up or down, thus raising or lowering the right side of the mower deck.
2. Loosen (and turn as needed) the top nut; turn the self-locking nut to adjust the position of the connecting link on the lift rod.
3. To raise the right side of the mower deck, turn both nuts upward, toward the lawn tractor frame. To lower the right side of the mower deck, turn both nuts downward, toward the mower deck.
4. Recheck the measurements of A and B. When a proper measurement is made, hold the regular nut in place, then securely tighten the self-locking nut.

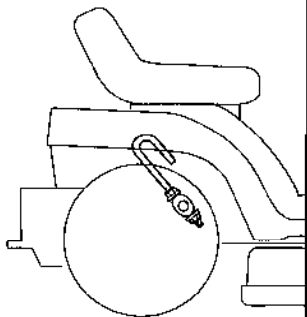

771DAFAA.C

Front-To-Rear Adjustments

INSPECTION

1. Prepare the lawn tractor as previously described. Put on heavy gloves when working near the blades. Move the height adjustment lever to 3.
2. Rotate right side blade only, so it is perpendicular to the front axle.
3. Measure the blade tip height at points A and B as shown.
4. Point A should be $1/4 \sim 1/2$ inch (6 ~ 12 mm) lower than point B. If point A is more than $1/2$ inch (12 mm) lower than point B, the front of the mower deck must be raised. If point A is less than $1/4$ inch (6 mm) lower than point B, the front of the mower deck must be lowered.

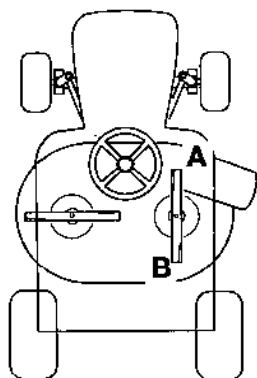

771BAAAB.CDR

ADJUSTMENT

1. Locate the two front links that attach the front of the mower deck to the frame.
2. Loosen (and turn as needed) the two regular nuts, then turn both self-locking nuts an equal number of turns to evenly adjust the length of both front links. To lower the front of mower deck, turn both nuts toward the front of the lawn tractor. To raise the front of mower deck, turn both nuts toward the mower deck.
3. Recheck the measurements of A and B. When a proper measurement is made, hold the two regular nuts in place, then securely tighten the two self-locking nuts.

RAISES
MOWER
DECK

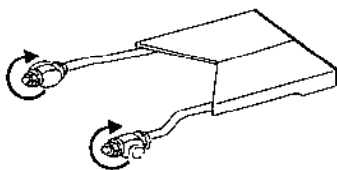

LOWERS
MOWER
DECK

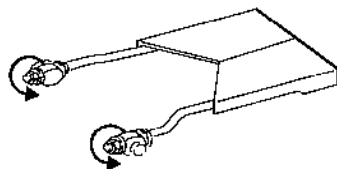

771DADAC.CDR

MAINTENANCE

BELTS

Your lawn tractor has two belts. The **blade belt** is used to transfer engine power to the mower deck blades. This is controlled by the PTO clutch lever. The **drive belt** is used to transfer engine power to the transmission. This is controlled by the clutch pedal.

Blade Belt

The blade belt should be inspected each time the lawn tractor is used.

Inspecting The Blade Belt

1. Park the lawn tractor on a flat, level surface. Set the parking brake, remove the ignition key and disconnect the spark plug cap.
2. Move the PTO clutch lever to **OFF**.
3. Lower the mower deck all the way down with the height adjustment lever
4. Examine the blade belt for cracks, tears or other physical damage. Replace the belt if it is damaged.
5. Move the PTO clutch lever to **ON**.
6. Check the blade belt; make sure it is snug and routed through all the belt guards, pulleys, and the PTO clutch tensioner arm.
7. Move the PTO clutch lever to **OFF**. Reconnect the spark plug cap.

Replacing The Blade Belt

There are multiple steps to replacing the blade belt:

- Remove the mower deck
- Remove the old blade belt
- Install the new blade belt
- Adjust blade belt tension

REMOVING THE OLD BLADE BELT

1. Remove the mower deck (page 80).
2. Remove the pulley cover on the left side of the mower deck.

⚠ CAUTION

The PTO clutch arm is under tension from a spring.

You can injure your hands or fingers if they are caught when moving the pulley or clutch arm.

Wear heavy gloves, and keep fingers and hands clear from the path of the moving PTO clutch arm.

3. Put on heavy gloves, and carefully move the belt tensioner arm to the ON position.
4. Loosen the bolt on belt guard A on the belt tensioner arm.
5. Move the blade belt off the tension roller on the belt tensioner arm.
6. Loosen the bolt, nut and washer on belt guard B.
7. Loosen the nuts holding belt guard D to the deck. Move belt guard D enough so the belt can be slipped between the guard and the right side pulley.

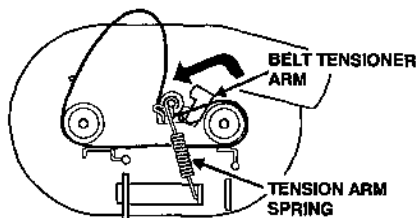

771DAGAA.CDR

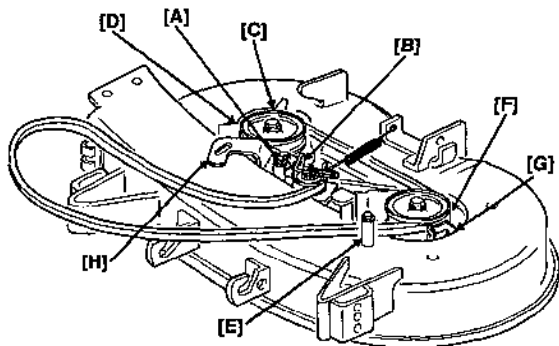

771DADAE.CDR

MAINTENANCE

- Loosen and remove the bolt on belt guard C. Remove the belt from the right side blade pulley.
- Loosen and remove the belt on belt guard F. Remove the belt from between the blade brake G and the left side pulley.
- Pull the belt away from the belt tensioner arm H and out from underneath the belt tensioner arm spring.
- Inspect the mower deck pulleys and belt guards, and remove any parts of the old blade belt that may still remain.

INSTALLING A NEW BLADE BELT

Installation is the reverse of removal, with a few important points:

- When tightening the bolts on belt guards C and F, gently press the guards toward the blade pulleys. Position the belt guards so there is 1/8 ~ 3/16 inch (3 ~ 5 mm) clearance between the pulleys and the guards.

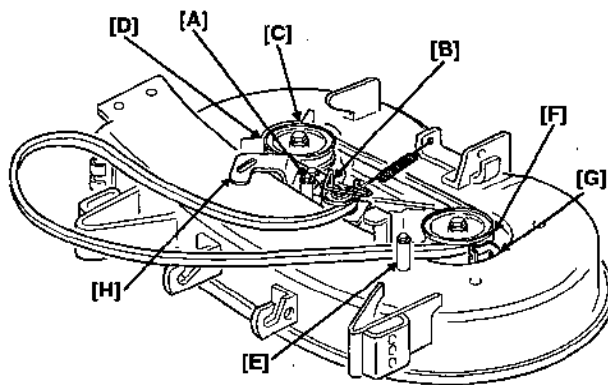

771DADA.E.CDR

- Make sure the belt is fully enclosed inside belt guard E before installing the left blade pulley cover
- Make sure belt guard A is tightened properly, using the hole on belt guard A and the alignment pin on the belt tensioner arm.
- When installing the mower deck, make sure the J-shaped rod is fully seated into the slots on the front brackets (page 83).

ADJUSTING BLADE BELT TENSION

This procedure should only be performed when a new blade belt is installed. Prepare the lawn tractor before attempting this adjustment:

- Make sure the mower deck has been adjusted for correct left-to-right and front-to-rear leveling. Make sure the anti-scalp rollers are not touching the ground.
 - Park the lawn tractor on a flat, level surface. Set the parking brake, and remove the ignition key to prevent accidental starting.
1. Move the PTO lever to **ON** and the height adjustment lever to 1.

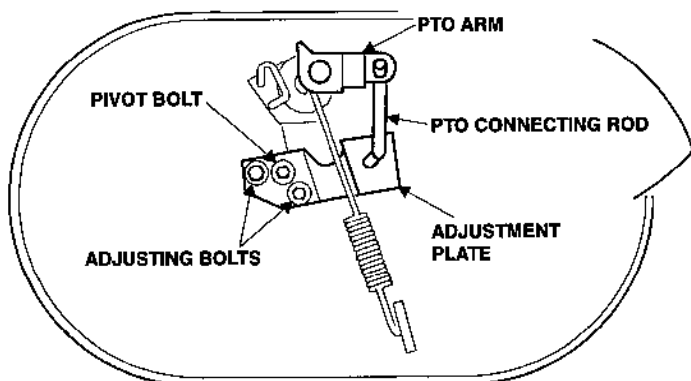

771DAHAA.CDR

2. The illustration above shows an overhead view of the mower deck and belt tensioner arm assembly. Locate and loosen (don't remove) the two adjusting bolts on the belt tensioner arm.
3. Rotate the belt tensioner arm forward or backward so the connecting rod contacts the forward edge of the slots in both the belt tensioner arm and PTO clutch rod. Tighten the two adjustment bolts, then push the rod forward to correct the adjustment.

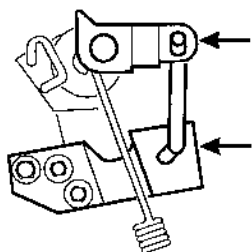

771DAHAB.CDR

MAINTENANCE

Drive Belt

The drive belt should be inspected at the interval specified in the Maintenance Schedule on page 60.

Inspection

1. Park the lawn tractor on a flat, level surface. Set the parking brake, remove the ignition key and disconnect the spark plug cap.
2. Securely block the front and rear wheels to prevent the lawn tractor from moving. Release the parking brake lever.
3. Lower the mower deck all the way down with the height adjustment lever.
4. Examine the drive belt for cracks, tears or other physical damage. Replace the belt if it is damaged.
5. Release the parking brake lever.
6. Check the drive belt; make sure it is snug and routed through all the belt guards, pulleys and the tensioner arm.
7. Reconnect the spark plug cap.

Replacement

Replacing the drive belt requires special tools (impact & torque wrenches) and is best left to an authorized Honda lawn tractor servicing dealer. See the *H2013 Shop Manual* for details.

TIRES AND WHEELS

Tires should be kept at the proper inflation pressure and periodically inspected for tread wear or damage. Keeping the tire treads clean and free of mud and other debris improves traction and steering control.

Tire pressure: Front:.....14 psi (98 kPa)

Rear:10 psi (69 kPa)

Do not attempt to remove a wheel, unless the lawn tractor is on firm, level ground, and you have the equipment and knowledge to do so properly. Circlip pliers are required to remove and install any wheel. Securely lock the wheels remaining on the ground.

Jack Points

Use the following points for jack pad placement. When lifting the rear section of the lawn tractor, don't place the jack pad on the transmission, or any other parts except the frame.

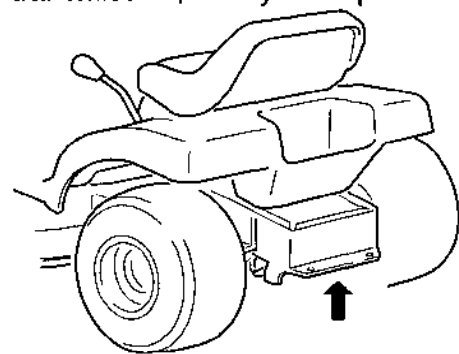

771JAAAB.CDR

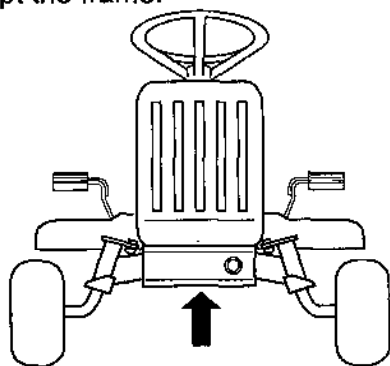

When lifting the front of the lawn tractor, be sure the jack pad is positioned on the axle housing only, and not any other part of the frame or steering linkage.

MAINTENANCE

Front Wheels

Removal

1. Place the lawn tractor on a flat, level surface, and set the parking brake. Block the rear wheels securely.

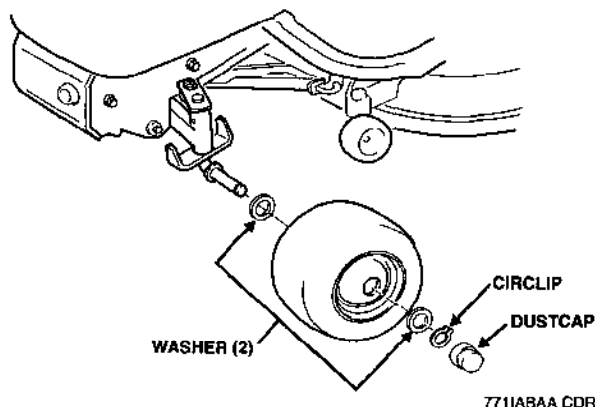

2. Lift and securely support the front end of the lawn tractor. Remove the dust cap, then use circlip pliers to remove and discard the old circlip. Remove the flat washer and wheel. Note that there is a second washer on the inside of the wheel.

Installation

1. Apply grease to the axle shaft and inside the wheel hub. If the inside flat washer was removed, install it back on the axle. Install the wheel and outside flat washer back onto the axle.
2. Install a new circlip. Do not use the old circlip. Circlips have a round side and a flat side. Install the new circlip with the flat side out, being careful not to expand the clip too far. Install the dustcap.

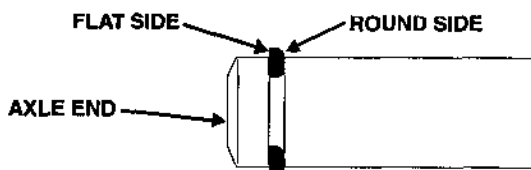

Rear Wheels

Removal

1. Block the front wheels securely. Lift and securely support the rear end of the lawn tractor. Remove the dust cap, then use circlip pliers to remove and discard the old circlip.
2. Remove the outside flat washer, then rotate the wheel, so the square key on the axle is upright and won't fall off when you remove the wheel.
3. Carefully pull the wheel and key straight off the axle. Note that there is a second washer on the inside of the wheel.
4. Be sure to remove the square key from the axle, otherwise, it can be difficult to get the wheel back on the axle properly.

Installation

1. Grease the axle thoroughly. If the inside flat washer was removed, install it back on the axle. Slide the wheel onto the axle. Line the keyway on the axle with the keyway on the inside of the wheel. Install the square key between the axle and wheel.
2. Install the outside flat washer on the outside of the wheel and a new circlip. Do not use the old circlip. Circlips have a flat side and a round side. Install the circlip with the flat side out, being careful not to expand the clip too far. Replace the dust cap.

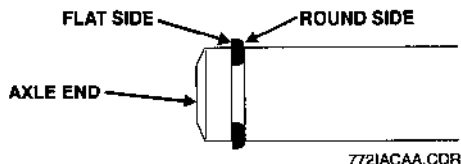

MAINTENANCE

OTHER ITEMS

Hydrostatic Fluid Reservoir (hydrostatic transmission model)

Inspect and add fluid (if necessary) to the hydrostatic fluid reservoir each time you use the lawn tractor.

Locate the reservoir on the right rear of the lawn tractor frame, next to the right rear tire. There are two level marks near the left bottom corner of the reservoir.

The fluid level should be between the two marks. Should you need to add fluid, be sure to clean the reservoir cap and surrounding area to avoid getting grass, dirt or debris into the reservoir. Use only Honda Hydrostatic Transmission Fluid.

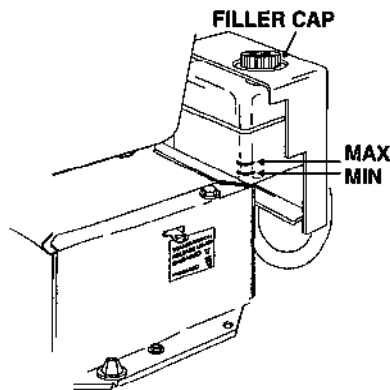

Clutch Pedal Freeplay (gear transmission model)

Inspect and adjust the clutch pedal freeplay at the interval specified in the Maintenance Schedule (page 60).

Inspection

1. Place a ruler so it is up against the clutch pedal arm.
2. Move the clutch pedal, and measure arm movement until resistance is felt.
3. Freeplay distance should be $1/4 \sim 5/8$ inch (6.3 ~ 16.1 mm). Adjust the freeplay when it is $1/4$ inch (6.3 mm) or less.

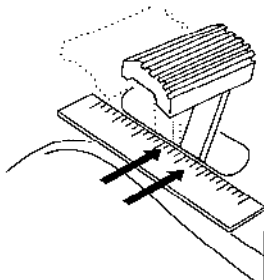

772CANAA.C

Adjustment

1. From the right side, look between the lawn tractor frame and the mower deck. Locate the clutch arm turnbuckle (outboard one) and lock nuts. The clutch arm runs along the inner left hand side of the lawn tractor frame.

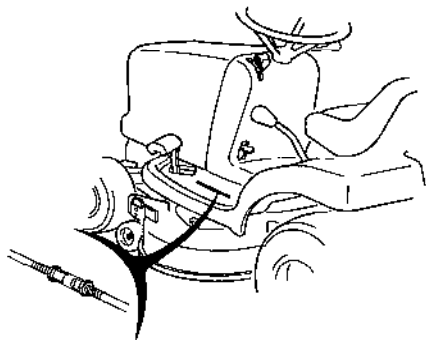

772CAIAA.CDR

2. The forward locking nut on the clutch arm turnbuckle is a standard right hand thread. The rear locking nut is a left hand thread. There are flat spots on the side of the turnbuckle for a 12 mm wrench.
3. To decrease freeplay, loosen both locknuts, and turn the turnbuckle to shorten the clutch rod.
4. To increase freeplay, loosen both the locknuts, and turn the turnbuckle to lengthen the clutch rod.
5. If adjustments fail to bring the freeplay to within $1/2 - 5/8$ inch (13.0 - 16.1 mm) the drive belt may need to be replaced.

MAINTENANCE

Lubrication Points

Grease: NGLI #2 Lithium Base EP

Lubricate the following grease points.

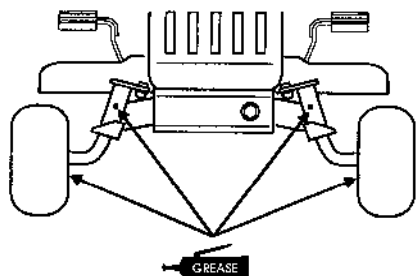

771JABAA.CDR
Front grease fittings

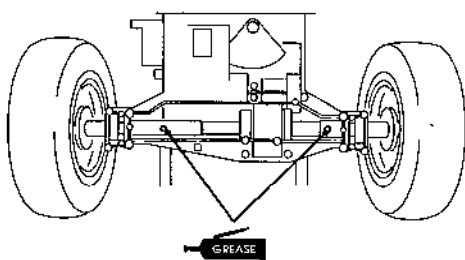

772JACAA.CDR
Rear axle shaft grease fittings
(gear transmission model only)

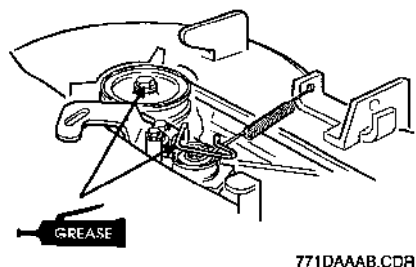

771DAAA.B.CDR
Blade belt tension arm pivot

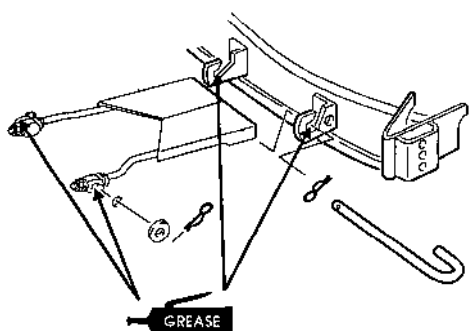

771DADAD.CDR
Front mower deck pivot points

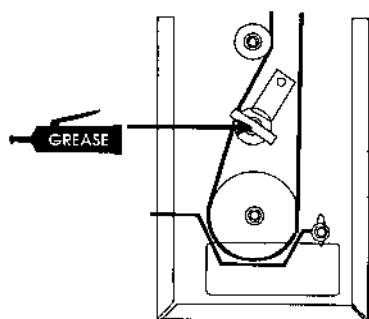

772QAAAA.CDR
Drive belt tension arm pivot
(gear transmission model only)

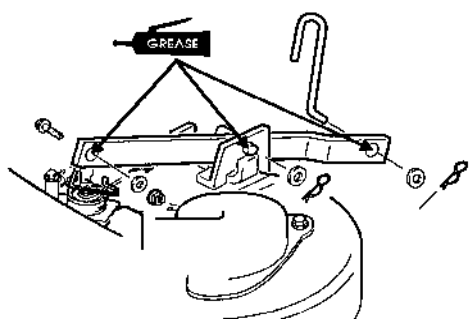

771DACAB.CDR
Rear mower deck pivot points

TROUBLESHOOTING

This section helps you to identify the problems, their causes and some corrective actions.

ENGINE PROBLEMS	103
DRIVE PROBLEMS	107
VIBRATION	107
MOWER DECK PROBLEMS	108

TROUBLESHOOTING

ENGINE PROBLEMS

Starter does not operate	Possible cause	Correction
Check shift lever position.	Shift lever not in NEUTRAL .	Move shift lever to NEUTRAL .
Check PTO clutch lever position.	PTO clutch lever is ON .	Move PTO clutch lever to OFF .
Safety interlock system operating.	Interlock switch on seat or parking brake lever not pressed.	Sit on seat or set the parking brake lever.
No electric current to starter.	Blown fuse, dead battery or relay.	Check fuse / relay; replace if necessary. Check battery; charge or replace.

Engine starts, then stops when operator rises off seat	Possible cause	Correction
Safety interlock system operating.	Controls not set for safe exit from lawn tractor.	PTO clutch lever must be OFF , shift lever must be in NEUTRAL and parking brake must be set.

TROUBLESHOOTING

Starter operates, but engine will not start	Possible cause	Correction
Check throttle position.	Throttle not in proper position.	Throttle must be in CHOKE for a cold engine or FAST for a warm engine.
Check fuel delivery to engine.	Fuel valve is OFF . Fuel filter clogged.	Move fuel valve to ON . Check for clogged fuel filter or obstructions in fuel tank.
Check fuel condition.	Stale or old fuel.	Be sure tank has fresh fuel.
Check for spark.	Spark plug cap off. Improper electrode gap or deposits in the spark plug gap.	Make sure cap is connected. Verify that spark plug is free of deposits, and has proper gap.

TROUBLESHOOTING

Engine has low power	Possible cause	Correction
Check ground speed.	Fast ground speed when mowing tall grass puts excessive load on engine.	Mow at slower ground speed.
Check mower deck height.	Too low mower deck height for grass puts excessive load on engine.	Raise height of mower deck.
Check mower deck.	Mower deck clogged with grass.	Clear mower deck of clogs.
Check air cleaner.	Dirty or clogged air filter(s) make engine run poorly.	Clean and replace air filter(s) as needed.
Check spark plug.	Spark plug cap not secure. Improper electrode gap or deposits on gap.	Make sure spark plug cap is securely connected. Verify that the spark plug is free of deposits and has proper gap.
Check engine cooling.	Cooling air intake path and engine fan obstructed.	Inspect the cooling air intake path and engine fan; clear away any grass or obstructions.
Check spark arrester (optional part).	Optional spark arrester clogged or dirty.	Examine spark arrester, and make sure it is clean and free of any deposits or obstructions.

TROUBLESHOOTING

DRIVE PROBLEMS

Engine runs, but lawn tractor doesn't move	Possible cause	Correction
Check shift lever.	Shift lever still in NEUTRAL .	Move shift lever out of NEUTRAL .
Check parking brake.	Parking brake lever is engaged.	Release parking brake lever.
Check pedal(s) position.	Clutch and /or brake pedals not fully released.	Make sure clutch and/or brake pedals are fully released.
Check drive belt.	Drive belt worn, broken or not on pulleys.	See servicing Honda lawn tractor dealer.
Check transmission release (hydrostatic transmission model)	Lever is in the RELEASED position	Move lever to the ENGAGED position.

VIBRATION

Lawn tractor vibrates	Possible cause	Correction
Check blades.	Blades not in good condition.	Inspect blades, and replace if necessary.
Check mower deck.	Blades obstructed by grass, mud, etc.	Clear mower deck of any obstructions.
Check blade belt.	Blade belt worn or not properly installed.	Inspect blade belt, and make sure it is properly installed.

TROUBLESHOOTING

MOWER DECK PROBLEMS

Won't cut grass	Possible cause	Correction
Check PTO clutch lever position.	PTO clutch not ON .	Move PTO clutch lever to ON .
Check mower deck height adjustment lever.	Mower deck height not properly set.	Adjust mower deck height to grass conditions.
Check blade belt.	Blade belt worn, not on pulleys or not properly installed.	Inspect blade belt and make sure it is properly installed.

Poor cut quality	Possible cause	Correction
Check throttle position.	Blades spinning too slowly.	Keep throttle in FAST when mowing.
Check mower deck.	Blades obstructed by grass, mud, etc.	Clear mower deck of any obstructions.
Check ground speed.	Lawn tractor moving too fast for mowing conditions.	Use shift lever to reduce ground speed.
Check mower deck height.	Mower deck height set too low for grass conditions.	Adjust mower deck height to obtain suitable cut quality.
Check grass conditions.	Wet grass is difficult to mow.	Mow only when grass is dry.
Check mower deck level.	Mower deck not properly level.	Adjust mower deck level.
Check blades.	Blade bent, cracked or dull.	Inspect, sharpen, or replace blade as needed.
Check blade belt.	Belt worn or not properly installed.	Inspect blade belt and make sure it is properly installed.

TROUBLESHOOTING

Grass not discharging properly	Possible cause	Correction
Check throttle position.	Blades spinning too slowly.	Keep throttle in FAST when mowing.
Check mower deck height adjustment lever.	Mower deck set too high up.	Adjust mower deck height to grass conditions.
Check blade belt.	Blade belt worn, not on pulleys or not properly installed.	Inspect blade belt and make sure it is properly installed.
Check grass conditions.	Wet grass is difficult to mow.	Mow only when grass is dry.
Check mowing overlap.	Too little overlap.	Adjust overlap as required for mowing conditions.
Check ground speed.	Lawn tractor moving too fast for mowing conditions.	Use shift lever to reduce ground speed.
Check blades.	Blades installed incorrectly.	Make sure both blades are correctly installed.

Engine stalls when PTO clutch lever is set to ON	Possible cause	Correction
Check throttle position.	Engine running too slow.	Keep throttle in FAST when mowing.
Check mower deck.	Blades obstructed by grass, mud, etc.	Clear mower deck of any obstructions.
Check optional grass bag chute.	Blades obstructed by clog in grass bag chute.	Clear grass bag chute of any clogs or obstructions.

STORAGE

This section explains how to protect your lawn tractor from rust and corrosion, and ensure that it will start easily when you want to use it again.

Cleaning	112
Engine	112
Mower Deck	112
Fuel	114
Adding a Gasoline Stabilizer to Extend Fuel Storage Life.....	114
Draining the Fuel Tank and Carburetor	115
Engine Oil	115
Grease	115
Tires	115

STORAGE

STORAGE PREPARATION

Proper storage preparation is essential for keeping your lawn tractor trouble free and looking good. The following steps will help to keep rust and corrosion from impairing your lawn tractor's function and appearance, and will make the engine easier to start when you use the lawn tractor again.

Cleaning

1. Wash the lawn tractor, including the underside of the mower deck.

Engine

Wash the engine by hand, and be careful to prevent water from entering the air cleaner.

NOTICE

- Using a garden hose or pressure washing equipment can force water into the air cleaner. Water in the air cleaner will soak the filter elements and can enter the carburetor or engine cylinder, causing damage.
- Water contacting a hot engine can cause damage. If the engine has been running, allow it to cool for at least half an hour before washing.

Mower Deck

If using a garden hose or pressure washing equipment to clean the mower deck, be careful to avoid getting water on the belts.

NOTICE

Spraying water on hot mower deck bearings can cause them to be damaged from cooling too quickly.

Before washing the underside of the mower deck, be sure the parking brake is set and the height adjustment lever is all the way up.

Grass Bag (optional kit)

Remove the grass bags from the hopper frame, and wash them with a garden hose or pressure washing equipment. Allow the bags to completely dry before storage.

2. After washing the lawn tractor, wipe dry all accessible surfaces.
3. Start the engine outdoors, and let it run until it reaches normal operating temperature to evaporate any water remaining on the engine.
4. While the engine is running, sit on the operator's seat and operate the PTO clutch lever to expel water from the blade pulleys, spindles, and other mower deck items. Allow the blades to spin for several minutes to ensure that no water remains.
5. Stop the engine and allow it to cool.
6. After the lawn tractor is clean and dry, touch up any damaged paint and coat other areas with a light film oil. Lubricate the throttle cable core with a silicone spray lubricant.

STORAGE

Fuel

Gasoline will oxidize and deteriorate in storage. Old gasoline will cause hard starting, and it leaves gum deposits that clog the fuel system. If the gasoline in your lawn tractor deteriorates during storage, you may need to have the carburetor and other fuel system components serviced or replaced.

The length of time that gasoline can be left in your fuel tank and carburetor without causing functional problems will vary with such factors as gasoline blend, your storage temperatures, and whether the fuel tank is partially or completely filled. The air in a partially filled fuel tank promotes fuel deterioration. Very warm storage temperatures accelerate fuel deterioration. Fuel deterioration problems may occur within a few months, or even less if the gasoline was not fresh when you filled the fuel tank.

Fuel system damage or engine performance problems resulting from neglected storage preparation are not covered under warranty.

You can extend fuel storage life by adding a gasoline stabilizer that is formulated for that purpose, or you can avoid fuel deterioration problems by draining the fuel tank and carburetor.

Adding a Gasoline Stabilizer to Extend Fuel Storage Life

When adding a gasoline stabilizer, fill the fuel tank with fresh gasoline. If only partially filled, air in the tank will promote fuel deterioration during storage. If you keep a container of gasoline for refueling, be sure that it contains only fresh gasoline.

1. Add gasoline stabilizer following manufacturer's instructions.
2. After adding a gasoline stabilizer, run the engine outdoors for 10 minutes to be sure that treated gasoline has replaced the untreated gasoline in the carburetor.
3. Stop the engine, and turn the fuel valve to the **OFF** position.

Draining the Fuel Tank and Carburetor

1. Loosen the carburetor drain screw and turn the fuel valve **ON**.

⚠ WARNING

Gasoline is highly flammable and explosive. You can be burned or seriously injured when handling fuel.

- Stop the engine and keep heat, sparks, and flame away.
- Refuel only outdoors.
- Wipe up spills immediately.

2. Drain the fuel into an approved gasoline container. Tighten the drain screw.

Engine Oil

1. Change the engine oil (see page 66).
2. Remove the spark plug (see page 68).
3. Pour a tablespoon (5 ~ 10 cc) of clean engine oil into the cylinder.
4. Operate the electric starter for a few seconds to distribute the oil in the cylinder.
5. Reinstall the spark plug.

Grease

Lubricate all grease points (see page 102).

Tires

Check tire air pressure (see page 22).

STORAGE

PLACING IN STORAGE

If your lawn tractor will be stored with gasoline in the fuel tank and carburetor, it is important to reduce the hazard of gasoline vapor ignition. Select a well-ventilated storage area away from any appliance that operates with a flame, such as a furnace, water heater, or clothes dryer. Also avoid any area with a spark-producing electric motor, or where power tools are operated.

If possible, avoid storage areas with high humidity, because that promotes rust and corrosion.

Unless all fuel has been drained from the fuel tank, leave the fuel valve in the **OFF** position to reduce the possibility of fuel leakage.

Park the lawn tractor on a level surface. Tilting can cause fuel or oil leakage.

With the engine and exhaust system cool, cover the lawn tractor to keep out dust. A hot engine and exhaust system can ignite or melt some materials. Do not use sheet plastic as a dust cover. A nonporous cover will trap moisture around the lawn tractor, promoting rust and corrosion.

Recharge the battery once a month while the lawn tractor is in storage. This will help to extend the service life of the battery.

REMOVAL FROM STORAGE

Check your lawn tractor as described in the *Before Mowing* chapter of this manual.

If the fuel was drained during storage preparation, fill the tank with fresh gasoline. If you keep a container of gasoline for refueling, be sure that it contains only fresh gasoline. Gasoline oxidizes and deteriorates over time, causing hard starting.

If the cylinder was coated with oil during storage preparation, the engine may smoke briefly at startup. This is normal.

STORAGE

SPECIFICATIONS

This chapter gives dimensions, capacities, and other technical information.

LAWN TRACTOR MODEL	120
DIMENSIONS, WEIGHTS, AND CAPACITIES	120
ENGINE DESIGN AND PERFORMANCE	120
TRANSMISSION DESIGN AND PERFORMANCE	121
MOWER DECK DESIGN AND PERFORMANCE	121
MAINTENANCE.....	121
TUNEUP	122
MISCELLANEOUS SPECIFICATIONS	122
OPTIONS	122

SPECIFICATIONS

LAWN TRACTOR MODEL

H2013SDA	Gear transmission, side-discharge, U.S.A. model
H2013HDA	Hydrostatic transmission, side-discharge, U.S.A. model

DIMENSIONS, WEIGHTS, AND CAPACITIES

Length	SDA: 66 inches (1670 mm) HDA: 67 inches (1700 mm)
Width	Lawn tractor: 36 inches (921 mm) w/mower deck installed: 49 inches (1250 mm)
Height	40.5 inches (1030 mm)
Wheel Base	45 inches (1135 mm)
Dry Weight	SDA Lawn tractor: 340 pounds (154 kg) HDA Lawn tractor: 375 pounds (170 kg) CD2038 (mower deck): 83 pounds (37.5 kg)
Front Tires	13 x 6.5-6 14 psi (98 kPa)
Rear Tires	18 x 8.5-8 10 psi (69 kPa)
Fuel Tank Capacity	1.3 U.S. gallons (5.3 ℓ)
Engine Oil Capacity	1.16 U.S. quarts (1.1 ℓ)

ENGINE DESIGN AND PERFORMANCE

Engine Model	GXV390
Engine Type	4-stroke, overhead-valve, air cooled
Displacement	23.7 cubic inches (389 cc)
Bore and Stroke	3.46 x 2.52 inches (88 x 64 mm)
Compression Ratio	7.7 : 1
Ignition System	Transistorized magneto
Maximum Power	13 hp (9.7 kW) at 3,600 rpm
Maximum Torque	20.3 ft-lb (27.5 N·m) at 2,500 rpm
Rated Engine Speeds	3,300 rpm (Throttle at FAST, PTO off) 1,750 rpm (Throttle at SLOW, PTO off)

SPECIFICATIONS

TRANSMISSION DESIGN AND PERFORMANCE

Type	H2013HDA: Hydrostatic, fluid drive	H2013SDA: Gear drive, parallel shaft, constant mesh, sliding key
Speeds	Infinitely variable	Five forward / one reverse
Ground Speeds	Mowing: 0 ~ 3.2 mph (0 ~ 5.1 km/h) Transport: 3.3 ~ 4.5 mph (5.2 ~ 7.3 km/h) Reverse: 0 ~ 2.2 mph (0 ~ 3.6 km/h)	First: 1.4 mph (2.4 km/h) Second: 2.0 mph (3.1 km/h) Third: 3.0 mph (4.9 km/h) Fourth: 3.9 mph (6.2 km/h) Fifth: 4.5 mph (7.3 km/h) Reverse: 2.2 mph (3.6 km/h)
Lube	3.28 quarts (3.1 ℓ) Honda hydrostatic transmission oil	Factory sealed; no maintenance required

MOWER DECK DESIGN AND PERFORMANCE

Type	Twin blade, belt drive, four-point link, dual anti-scalp rollers, side discharge model
Size	38 inches (974 mm)
Height Range	1 ~ 4 inches (25.4 mm ~ 96.4 mm)
Blade Brake	Mechanical arms
Adjustments	Left & right and front & rear height adjustments plus anti-scalp roller height adjustments

MAINTENANCE

Fuel	Unleaded gasoline with a pump octane rating of 86 or higher
Engine Oil	SAE 10W-30; API SF, SG, or equivalent for general use
Spark Plug Type	NGK: BPR5ES or ND: W16EPRU
Maximum Governed Engine Speed	3,300 rpm
Blade Bolt Torque	43.4 ft-lb (60 Nm)

SPECIFICATIONS

TUNEUP

Spark Plug Gap	0.028 ~ 0.031 inch (0.7 ~ 0.8 mm)
Engine Idle Speed (PTO clutch lever OFF)	1,750 +200/-0 rpm
Valve Clearance (cold)	Intake: 0.10 ± 0.02 mm Exhaust: 0.15 ± 0.02 mm
Other Specifications	No adjustments needed

MISCELLANEOUS SPECIFICATIONS

Minimum Uncut Grass Diameter (left turn)	51.2 inches (1300 mm)
Brakes	Cam disc
Battery	U1-L (12V/RC 22min CCA 170A)
Fuse	5 amps, blade type

OPTIONS

Mulching kit	Includes two blades, guides and plug
Grass bag kit	Features twin bags, steel frame, chutes and all necessary hardware.
Front guard	Protects front of the lawn tractor
Trailer hitch	For use with a light duty attachment or trailer.
Snowblower	40 inch, two-stage, includes subframe
Light kit	For use with the snowblower; halogen lamp and weather resistant switch

ADDITIONAL INFORMATION

This chapter contains additional information, including serial number locations, Honda publications available to you, and tells you how to contact us if you have a question or warranty repair problem.

SERIAL NUMBER LOCATIONS	124
HONDA PUBLICATIONS	125
Shop Manual	125
Parts Catalog.....	125
WARRANTY SERVICE INFORMATION	126
OXYGENATED FUELS	127
SPARK ARRESTER SERVICE (optional part)	128

ADDITIONAL INFORMATION

SERIAL NUMBER LOCATIONS

Your lawn tractor has both a frame [A] and engine [B] serial number; use the following illustrations to locate the numbers when needed.

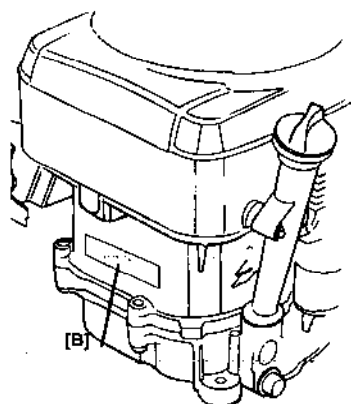
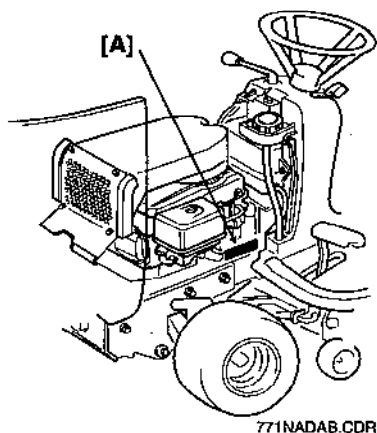

Raise the engine hood to view the frame serial number on the left side of the frame. The engine serial number is stamped into the engine block side that is closest to the fuel tank. You need an inspection mirror to see it.

HONDA PUBLICATIONS

These publications will give you additional information for maintaining and repairing your lawn tractor. You may order them from your Honda lawn tractor dealer.

Shop Manual

This manual covers complete maintenance and overhaul procedures. It is intended to be used by a skilled technician.

Parts Catalog

This manual provides complete, illustrated parts lists.

ADDITIONAL INFORMATION

WARRANTY SERVICE INFORMATION

Honda Power Equipment dealership personnel are trained professionals. They should be able to answer any question you may have. If you encounter a problem that your dealer does not solve to your satisfaction, please discuss it with the dealership's management. The Service Manager or General Manager can help. Almost all problems are solved in this way.

If you are dissatisfied with the decision made by the dealership's management, contact the Honda Power Equipment Customer Relations Office. You can write:

American Honda Power Equipment Division
Customer Relations Office
4475A River Green Parkway
Duluth, Georgia 30136-2565

or telephone:

(770) 497-6400

When you write or call, please give us this information:

- Model and serial numbers (see page 124)
- Name of the dealer who sold the lawn tractor to you
- Name and address of the dealer who services your lawn tractor
- Date of purchase
- Your name, address, and telephone number
- A detailed description of the problem

Current customer service contact information:

United States, Puerto Rico, and U.S. Virgin Islands:

Honda Power Equipment dealership personnel are trained professionals. They should be able to answer any question you may have. If you encounter a problem that your dealer does not solve to your satisfaction, please discuss it with the dealership's management. The Service Manager or General Manager can help. Almost all problems are solved in this way.

If you are dissatisfied with the decision made by the dealership's management, contact the Honda Power Equipment Customer Relations Office. You can write:

American Honda Motor Co., Inc.
Power Equipment Division
Customer Relations Office
4900 Marconi Drive
Alpharetta, GA 30005-8847

Or telephone: (770) 497-6400 M-F, 8:30 am - 7:00 pm EST

When you write or call, please provide the following information:

- Model and serial numbers
- Name of the dealer who sold the Honda power equipment to you
- Name and address of the dealer who services your equipment
- Date of purchase
- Your name, address, and telephone number
- A detailed description of the problem

OXYGENATED FUELS

Some conventional gasolines are being blended with alcohol or an ether compound. These gasolines are collectively referred to as oxygenated fuels. To meet clean air standards, some areas of the United States and Canada use oxygenated fuels to help reduce emissions.

If you use an oxygenated fuel, be sure it is unleaded and meets the minimum octane rating requirement.

Before using an oxygenated fuel, try to confirm the fuel's contents. Some states/provinces require this information to be posted on the pump.

The following are the EPA approved percentages of oxygenates:

ETHANOL -----(ethyl or grain alcohol) 10% by volume

You may use gasoline containing up to 10% ethanol by volume. Gasoline containing ethanol may be marketed under the name "Gasohol".

MTBE -----(Methyl Tertiary Butyl Ether) 15% by volume

You may use gasoline containing up to 15% MTBE by volume.

METHANOL --- (methyl or wood alcohol) 5% by volume

You may use gasoline containing up to 5% methanol by volume, as long as it also contains cosolvents and corrosion inhibitors to protect the fuel system. Gasoline containing more than 5% methanol by volume may cause starting and/or performance problems. It may also damage metal, rubber, and plastic parts of your fuel system.

If you notice any undesirable operating symptoms, try another service station, or switch to another brand of gasoline.

Fuel system damage or performance problems resulting from the use of an oxygenated fuel containing more than the percentages of oxygenates mentioned above are not covered under warranty.

ADDITIONAL INFORMATION

SPARK ARRESTER SERVICE (optional part)

The spark arrester is not standard on your lawn tractor, but may be required for legal operation in some areas. If a spark arrester is installed on your lawn tractor, it should be inspected, cleaned and replaced if necessary.

NOTICE

The spark arrester must be serviced every 100 hours to maintain its efficiency.

If the engine has been running, the muffler will be very hot. Allow the muffler to cool before servicing the spark arrester.

1. Locate the muffler and spark arrester on the front of the lawn tractor. Remove the hold-down screw holding the spark arrester to the muffler, then remove the spark arrester.
2. Remove the single screw holding the two parts of the spark arrester together.
3. Use a brush to remove carbon deposits from the spark arrester screen. Inspect the spark arrester screen for holes or tears. Replace it if it is damaged.
4. Reinstall all parts in the reverse order of removal.

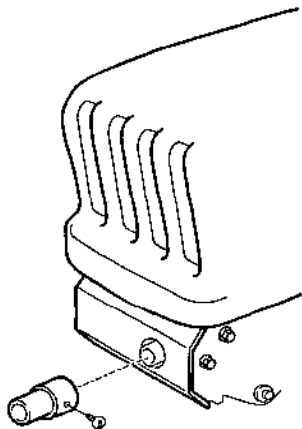

—A—

- air filter
 - cleaning..... 64
- air filter inspection 25
- air filters
 - inspection..... 64
- altitude, operation at high 72
- anti-scalp rollers 79

—B—

- battery
 - charging 75
 - inspection..... 75
 - installation 76
 - removal 75
- belts.... See blade belt or drive belt
- blade
 - best speed for mowing..... 44
 - bolt torque 88
 - inspection..... 84
 - installation 88
 - removal 86
 - sharpening 87
 - sharpness for mowing..... 45
- blade belt
 - inspection..... 92
 - replacement 92

brake

- braking procedure..... 34
- pad wear inspection 78
- pedal freeplay adjustment..... 78
- pedal freeplay inspection 77
- brake pedal
 - checking operation..... 23
 - description..... 16

—C—

- carburetor
 - adjustment 70
 - draining 115
 - high altitude operation..... 72
- cleaning
 - engine 112
 - grass bag 113

- mower deck..... 112
- clogged mower deck..... 45
- clothing
 - protective 28
 - recommended 28
- clutch pedal
 - description 15
 - freeplay adjustment 101
 - freeplay inspection..... 100
- controls
 - descriptions 14
 - locations 12

—D—

- drive belt inspection 96

—E—

- electrical maintenance 74
- emission
 - California Clean Air Act 58
 - problems..... 58
 - source of..... 58
 - tampering and altering..... 58
- engine
 - cleaning 112
 - hood..... 63
 - problems..... 104
 - starting..... 31

—F—

- fuel
 - draining the fuel tank 115
 - filter replacement..... 71
 - octane..... 73
 - oxygenated 127
 - recommendations..... 73
 - refueling..... 24
 - using a stabilizer 114
- fuel valve description 14
- fuse
 - location 76
 - replacement..... 76

INDEX

—G—

- grass bag cleaning.....113
- grease points102

—H—

- height adjustment lever.....15
- height of the mower deck43
- hood, engine63
- hydrostatic fluid reservoir100

—I—

- ignition switch.....14

—J—

- jack points97

—L—

- lawn tractor
 - check before operation.....21
 - problems.....107
- lawn, check before mowing20
- leaves, mowing45
- lifting points97
- loading52
- lubrication points102

—M—

- maintenance
 - access points.....61
 - importance of.....55
 - responsibility59
 - safety56
 - safety precautions56
 - schedule60

mower deck

- anti-scalp rollers79
- cleaning112
- clearing a clog45
- front-to-rear leveling91
- inspection & adjustment89
- left-to-right leveling90
- problems.....108

mowing

- best speed to use44

- fallen leaves45
- grass conditions45
- near obstacles.....41
- patterns for bagging46
- patterns for mulching46
- patterns for side-discharge46
- precautions30
- procedure37
- setting the cutting height43
- when to mow43
- widths44
- muffler, inspection23

—O—

- octane..... *See fuel*
- oil
 - changing.....66
 - checking level21
 - recommended engine oil.....66

—P—

- parking brake lever
 - checking operation.....23
 - description.....17
- parts catalog.....125
- parts, replacement59
- problems
 - engine104
 - lawn tractor.....107
 - mower deck.....108
 - vibration.....107
- PTO clutch lever.....18
- publications125

—S—

safety

- child safety message10
- important information6
- label locations8
- maintenance56
- message descriptions2
- towing.....48

seat

- adjusting.....62
- description.....14

lowering.....	62
raising	62
serial number locations	124
shift lever.....	15
shifting gears	35
shop manual.....	125
slope	
operation on	40
starting on	41
spark arrester.....	128
spark plug	
gap	68
maintenance	68
recommended types	68
specifications.....	120
speed	
adjusting ground speed.....	35
best for mowing.....	44
steering.....	33
stopping	
the blades	37
the lawn tractor	38
storage	
fuel considerations	114
preparation.....	112
removal from.....	117

—T—

throttle.....	17
tire pressure.....	97
tires	
checking pressure	22
towing	
safety	48
weight limits	49
transmission release.....	18
transporting	See loading
troubleshooting	
engine problems	104
lawn tractor problems	107
mower deck problems	108

—V—

vibration problems	107
--------------------------	-----

—W—

warranty service.....	126
weight limits, towing.....	49
wheel	
installation.....	99
removal.....	98

Fuel	Type	Unleaded gasoline with a pump octane rating of 86 or higher
	Capacity	5.3 ℓ (1.3 U.S. gallons)
Engine Oil	Type	SAE 10W-30 API SF, SG or equivalent for general use
	Capacity	1.1 ℓ (1.16 U.S. quarts)
Spark Plug	Type	NGK: BPR5ES ND: W16EPR
	Electrode Gap	0.7 ~ 0.8 mm (0.028 ~ 0.031 inch)
Blade Bolt	Torque	58.9 N·m (43.4 ft·lb)
Carburetor	Idle Speed (PTO clutch lever OFF)	1,750 +200/-0 rpm
Tires	Front Rear	98 kPa (14 psi) 69 kPa (10 psi)
Maintenance	Before Each Use	<ul style="list-style-type: none"> Check blades and tightness Check grass bag Check engine oil level Check air cleaner Check cooling air intake path Check battery electrolyte level Check tire air pressure Check mower deck belt Check drive belt Check brake pedal operation Check clutch pedal operation Check parking brake operation
	First 20 Hours	<ul style="list-style-type: none"> Change engine oil Check blade bolt tightness Check brake and clutch pedal fastener tightness
	Subsequent	See Maintenance Schedule

HONDA

31771700
00X31-771-7000



Printed on
Recycled Paper



40.2002.06

PRINTED IN U.S.A.

