

HONDA

Power

Equipment

Owner's Manual

TILLER

FR600/FR800

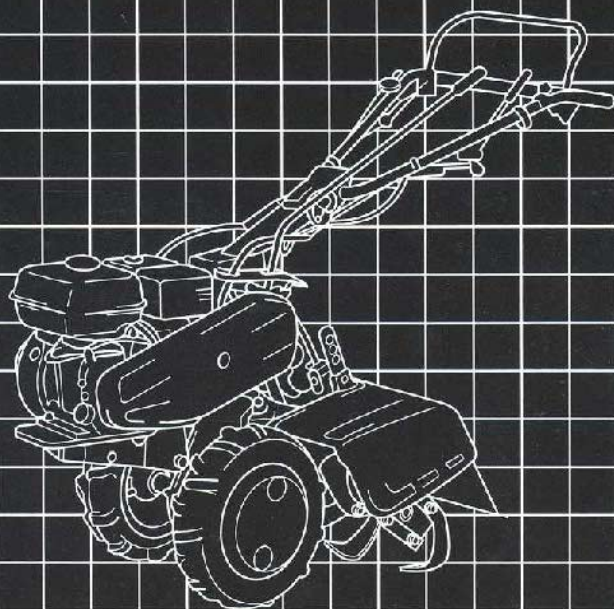



WARNING:



The engine exhaust from this product contains chemicals known to the State of California to cause cancer, birth defects or other reproductive harm.

Keep this owner's manual handy, so you can refer to it at any time. This owner's manual is considered a permanent part of the tiller and should remain with the tiller if resold.

The information and specifications included in this publication were in effect at the time of approval for printing. Illustrations are based on the FR800. Honda Motor Co., Ltd. reserves the right, however, to discontinue or change specifications or design at any time without notice and without incurring any obligation whatever. No part of this publication may be reproduced without written permission.

INTRODUCTION

Congratulations on your selection of a Honda tiller. We are certain you will be pleased with your purchase of one of the finest tillers on the market.

We want to help you get the best results from your new tiller and to operate it safely. This manual contains the information on how to do that; please read it carefully.

As you read this manual, you will find information preceded by a **NOTICE** symbol. That information is intended to help you avoid damage to your tiller, other property, or the environment.

We suggest you read the warranty policy to fully understand its coverage and your responsibilities of ownership. The warranty policy is a separate document that should have been given to you by your dealer.

When your tiller needs scheduled maintenance, keep in mind that your Honda servicing dealer is specially trained in servicing Honda tillers. Your Honda servicing dealer is dedicated to your satisfaction and will be pleased to answer your questions and concerns.

Best Wishes,
Honda Motor Co., Ltd.

INTRODUCTION

A FEW WORDS ABOUT SAFETY

Your safety and the safety of others are very important. And using this tiller safely is an important responsibility.

To help you make informed decisions about safety, we have provided operating procedures and other information on labels and in this manual. This information alerts you to potential hazards that could hurt you or others.

Of course, it is not practical or possible to warn you about all the hazards associated with operating or maintaining a tiller. You must use your own good judgment.

You will find important safety information in a variety of forms, including:

- **Safety Labels** — on the tiller.
- **Safety Messages** — preceded by a safety alert symbol  and one of three signal words, DANGER, WARNING, or CAUTION.

These signal words mean:

 **DANGER** You **WILL** be **KILLED** or **SERIOUSLY HURT** if you don't follow instructions.

 **WARNING** You **CAN** be **KILLED** or **SERIOUSLY HURT** if you don't follow instructions.

 **CAUTION** You **CAN** be **HURT** if you don't follow instructions.

- **Safety Headings** — such as *IMPORTANT SAFETY INFORMATION*.
- **Safety Section** — such as *TILLER SAFETY*.
- **Instructions** — how to use this tiller correctly and safely.

This entire book is filled with important safety information — please read it carefully.

1. TILLER SAFETY	5
Important Safety Information	5
Safety label locations.....	9
2. COMPONENT IDENTIFICATION	10
3. PRE-OPERATION CHECK	11
Engine Oil.....	11
Transmission Oil	12
Lower Chain Case Oil.....	12
Fuel	13
Air Filter.....	16
Tire Pressure.....	16
Tines	16
4. STARTING THE ENGINE	17
Starting.....	17
Clearing a Flooded Engine	19
5. TILLER OPERATION	20
Handlebar Height Adjustment	20
Tilling Depth Adjustment	20
Main Clutch Operation.....	20
Gear Selection	21
Tine Clutch Operation.....	22
Handling Tips	23
High Altitude Operation.....	24
6. STOPPING THE ENGINE	25
7. MAINTENANCE.....	26
The Importance of Maintenance	26
Maintenance Safety	27
Emission Control System Information	28
Air Index.....	30
Maintenance Schedule	31
Engine Oil Change	32
Transmission Oil Change	33
Air Filter Service	34
Fastener Tightness Check	35
Spark Plug Service	36
Spark Arrester Service (optional part).....	37
Sediment Cup Cleaning.....	38
Main Clutch Cable Adjustment	38

CONTENTS

Tine Clutch Cable Adjustment	39
Throttle Cable Adjustment	39
Drive Belt Adjustment.....	40
Upper Chain Adjustment.....	41
Tine Replacement	41
8. TRANSPORTING/STORAGE	42
Preparation for Storage	43
Storage.....	46
Removal from Storage	47
9. TROUBLESHOOTING	48
10. SPECIFICATIONS.....	49
11. WARRANTY SERVICE INFORMATION	50

IMPORTANT SAFETY INFORMATION

For your safety and the safety of others, pay special attention to these precautions:

Operator Responsibility

- Keep the tiller in good operating condition. Operating a tiller in poor or questionable condition could result in serious injury.
- Be sure all safety devices are in working order and warning labels are in place. These items are installed for your safety.
- Be sure the safety covers (V-belt cover, chain case cover and recoil starter cover) are in place.
- Know how to stop the engine and tines quickly in case of emergency. Understand the use of all controls.
- Be very cautious when operating the tiller in REVERSE, especially if attachments are being used.
- Keep a firm hold on the handlebars. They may tend to lift during clutch engagement.
- Allowing anyone to operate this tiller without proper instruction may result in injury.
- Wear sturdy, full-coverage footwear. Operating this tiller barefoot or with open toe shoes or sandals increases your risk of injury.
- Dress sensibly. Loose clothing may get caught in moving parts, increasing your risk of injury.
- Be alert. Operating this tiller when you are tired, ill or under the influence of alcohol or drugs may result in serious injury.
- Keep all persons and pets away from the tilling area.
- Be sure the drag bar is in place and properly adjusted.

Child Safety

- Keep children indoors and supervised at all times when any outdoor power equipment is being used nearby. Young children move quickly and are attracted especially to the tiller and the tilling activity.
- Never assume children will remain where you last saw them. Be alert and turn the tiller off if children enter the area.
- Children should never be allowed to operate the tiller, even under adult supervision.

Rotating Tines Hazard

The rotating tines are sharp and they turn at high speed. Accidental contact can cause serious injury.

- Keep your hands and feet away from the tines while the engine is running.
- Stop the engine and disengage the tine clutch before inspection or maintenance of tines.
- Disconnect the spark plug cap to prevent any possibility of accidental starting. Wear heavy gloves to protect your hands when cleaning the tines or when inspecting or replacing the tines.

Thrown Object Hazard

Objects hit by the rotating tines can be thrown from the tiller with great force, and may cause serious injury.

- Before tilling, clear the tilling area of sticks, large stones, wire, glass, etc. Till only in daylight.
- Always inspect the tiller for damage after striking a foreign object. Repair or replace any damaged parts before continuous use.
- Pieces thrown from worn or damaged tines can cause serious injury. Always inspect the tines before using the tiller.

Fire and Burn Hazard

Gasoline is extremely flammable, and gasoline vapor can explode. Use extreme care when handling gasoline. Keep gasoline out of reach of children.

- Refuel in a well-ventilated area with the engine stopped.
- Allow the engine to cool before refueling. Fuel vapor or spilled fuel may ignite.
- The engine and exhaust system become very hot during operation and remain hot for a while after stopping. Contact with hot engine components can cause burn injuries and can ignite some materials.
- Avoid touching a hot engine or exhaust system.
- Allow the engine to cool before performing maintenance or storing the tiller indoors.

Carbon Monoxide Poisoning Hazard

Exhaust contains poisonous carbon monoxide, a colorless and odorless gas. Breathing exhaust can cause loss of consciousness and may lead to death.

- If you run the engine in an area that is confined or even partially enclosed, the air you breathe could contain a dangerous amount of exhaust gas. To keep exhaust gas from building up, provide adequate ventilation.

Operation on Slope

- When tilling on slopes, keep the fuel tank less than half full to minimize fuel spillage.
- Till across the slope (at equally spaced intervals) rather than up and down it.
- Be very careful when changing the direction of the tiller on a slope.
- Do not use the tiller on a slope of more than 10°. The maximum safe grade angle mentioned above is for reference purpose only and should be determined according to the type of attachments. Before starting the engine, check that the tiller is not damaged and is in good condition. For your safety and safety of others, exercise extreme care when using the tiller on a slope.

SAFETY LABEL LOCATIONS

These labels warn you of potential hazards that can cause serious injury. Read them carefully. If a label comes off or becomes hard to read, contact your Honda tiller dealer for a replacement.

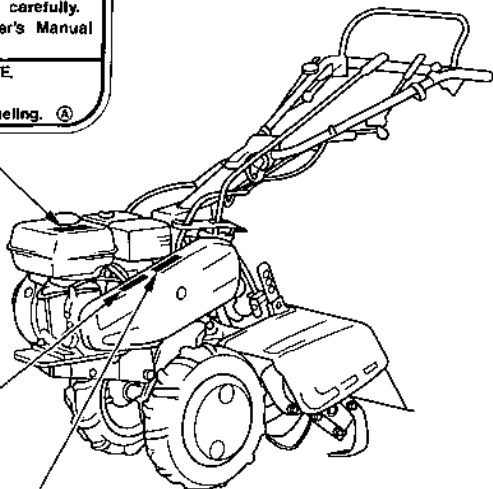
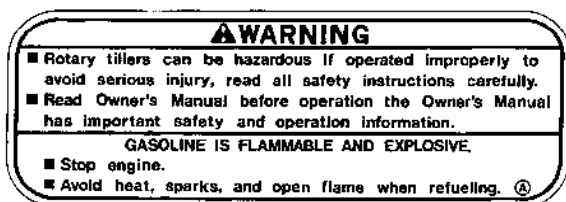
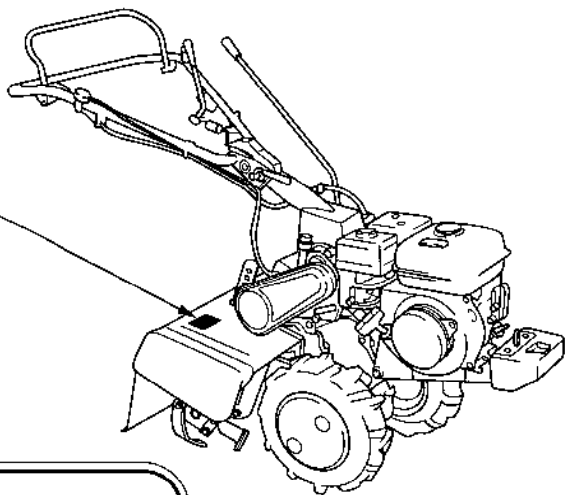
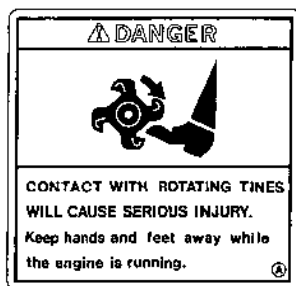

2. COMPONENT IDENTIFICATION

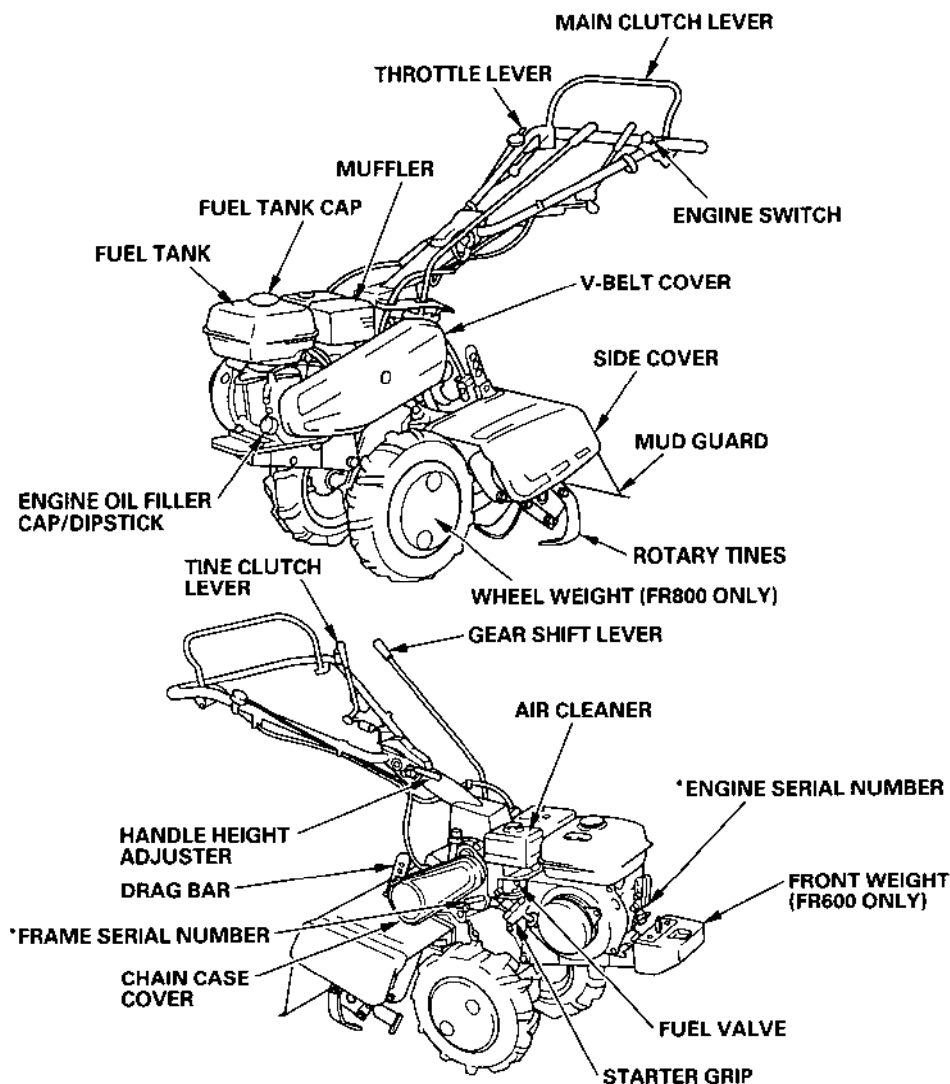

* Record the frame and engine serial numbers for your reference. Refer to the serial numbers when ordering parts, and when making technical or warranty inquiries (see page 50).

Frame serial number: _____

Engine serial number: _____

3. PRE-OPERATION CHECK

ENGINE OIL

Check the engine oil level with the engine stopped and in a level position.

1. Remove the oil filler cap/dipstick and wipe it clean.
2. Insert and remove the dipstick without screwing it into the filler neck. Check the oil level shown on the dipstick.
3. If the oil level is low, fill to the edge of the oil filler hole with the recommended oil.

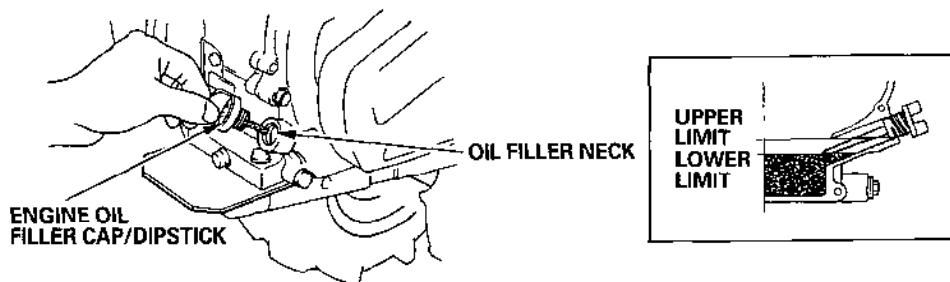

NOTICE

Running the engine with a low oil level will cause serious engine damage.

Use 4-stroke motor oil that meets or exceeds the requirements for API service classification SJ. Always check the API SERVICE label on the container to be sure it includes the letters SJ.

SAE 10W-30 is recommended for general use. Other viscosities shown in the following chart may be used when the average temperature in your area is within the indicated range.

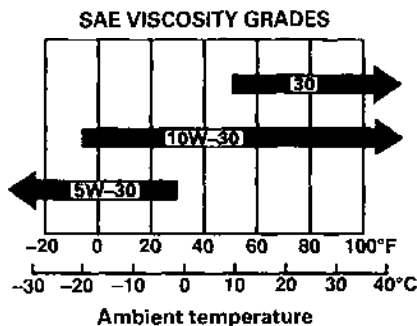

NOTICE

Using nondetergent oil can shorten the engine's service life, and using 2-stroke oil will damage the engine.

TRANSMISSION OIL

With the tiller on level ground, remove the oil filler cap and check to see if oil is up to the tip of the dipstick. Add engine oil if necessary (see page 11 for recommended oil).

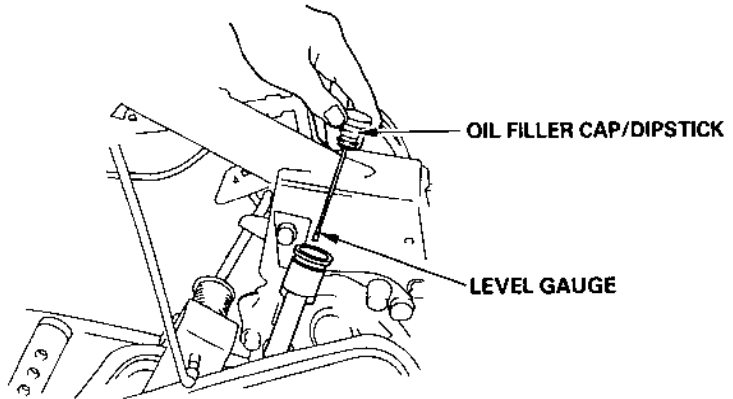

LOWER CHAIN CASE OIL

Place the tiller on level ground and remove the oil level check bolt. Remove the oil filler cap. The oil level should be up to the lower edge of the check bolt hole. If the level is low, add oil until it begins to flow out of the hole (see page 11 for recommended oil).

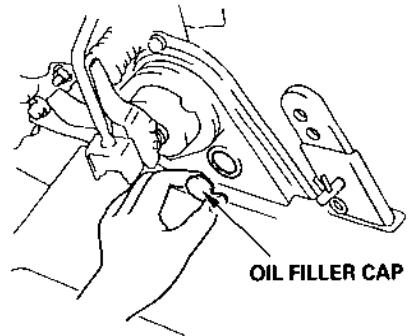
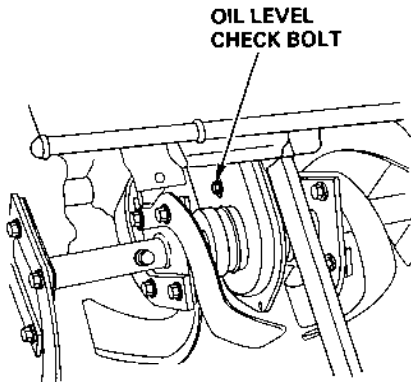

FUEL

Refueling

Stop the engine. Remove the fuel tank cap and check the fuel level. Refill the tank if the fuel level is low.

Fuel tank capacity: **FR600:** 0.95 US gal (3.6 l , 0.79 Imp gal)
FR800: 1.59 US gal (6.0 l , 1.32 Imp gal)

▲WARNING

Gasoline is highly flammable and explosive.

You can be burned or seriously injured when handling fuel.

- **Stop the engine and keep heat, sparks, and flame away.**
- **Handle fuel only outdoors.**
- **Wipe up spills immediately.**

After refueling, tighten the fuel tank cap securely. If any fuel was spilled, make sure the area is dry before starting the engine.

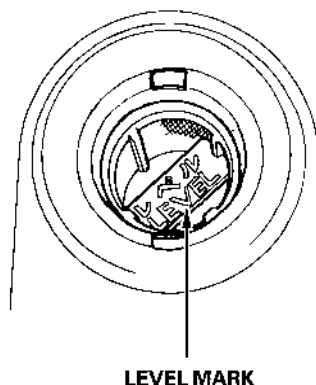

Use unleaded gasoline with a pump octane rating of 86 or higher.

This engine is certified to operate on unleaded gasoline. Unleaded gasoline produces fewer engine and spark plug deposits and extends exhaust system life.

Never use stale or contaminated gasoline or an oil/gasoline mixture. Avoid getting dirt or water in the fuel tank.

Occasionally you may hear light “spark knock” or “pinging” (metallic rapping noise) while operating under heavy loads. This is no cause for concern.

If spark knock or pinging occurs at a steady engine speed, under normal load, change brands of gasoline. If spark knock or pinging persists, see an authorized Honda tiller dealer.

NOTICE

Running the engine with persistent spark knock or pinging can cause engine damage.

NOTE:

Running the engine with persistent spark knock or pinging is considered misuse, and the Distributor's Limited Warranty does not cover parts damaged by misuse.

Oxygenated Fuels

Some conventional gasolines are being blended with alcohol or an ether compound. These gasolines are collectively referred to as oxygenated fuels. To meet clean air standards, some areas of the United States and Canada use oxygenated fuels to help reduce emissions.

If you use an oxygenated fuel, be sure it is unleaded and meets the minimum octane rating requirement.

Before using an oxygenated fuel, try to confirm the fuel's contents. Some states/provinces require this information to be posted on the pump.

The following are the EPA approved percentages of oxygenates:

ETHANOL— (ethyl or grain alcohol) 10% by volume
You may use gasoline containing up to 10% ethanol by volume. Gasoline containing ethanol may be marketed under the name "Gasohol".

MTBE— (methyl tertiary butyl ether) 15% by volume
You may use gasoline containing up to 15% MTBE by volume.

METHANOL— (methyl or wood alcohol) 5% by volume
You may use gasoline containing up to 5% methanol by volume as long as it also contains cosolvents and corrosion inhibitors to protect the fuel system. Gasoline containing more than 5% methanol by volume may cause starting and/or performance problems. It may also damage metal, rubber, and plastic parts of your fuel system.

If you notice any undesirable operating symptoms, try another service station or switch to another brand of gasoline.

Fuel system damage or performance problems resulting from the use of an oxygenated fuel containing more than the percentages of oxygenates mentioned above are not covered under warranty.

AIR FILTER

Remove the cover wing nut, then remove the air cleaner cover.

Inspect the air filter elements. If the elements are dirty, clean them as described on page 34.

Replace the elements if they are damaged.

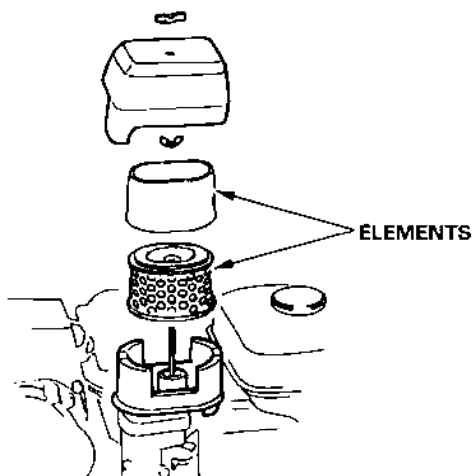

NOTICE

Operating the engine without an air filter, or with a damaged air filter, will allow dirt to enter the engine, causing rapid engine wear. This type of damage is not covered by the Distributor's Limited Warranty.

TIRE PRESSURE

Excessive tire pressure will reduce traction, and underinflation may result in abnormal or accelerated tire wear. For best performance, keep the tires inflated to:

17 psi (118 kPa , 1.20 kgf/cm²)

TINES

Inspect the tines, and replace them if they are worn or damaged (see page 41). Be sure all nuts and bolts are tight.

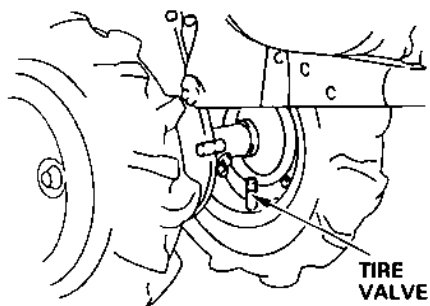

4. STARTING THE ENGINE

Be sure the main clutch is disengaged and the shift lever is in the neutral position to prevent sudden uncontrolled movement when the engine starts. The clutch is engaged by squeezing the clutch lever and disengaged by releasing the lever.

1. Turn the fuel valve to the ON position.
Be sure that the drain knob is tightened securely.

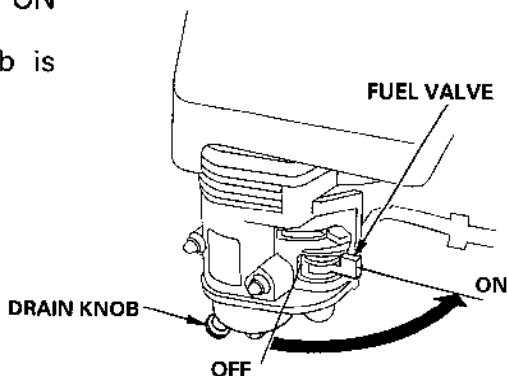

2. Turn the engine switch to the ON position.

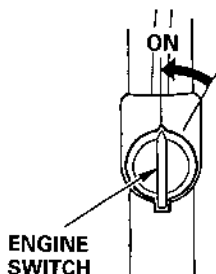

3. Turn the choke lever to the CLOSED position.

NOTE:

Do not use the choke if the engine is warm or the outside air temperature is warm.

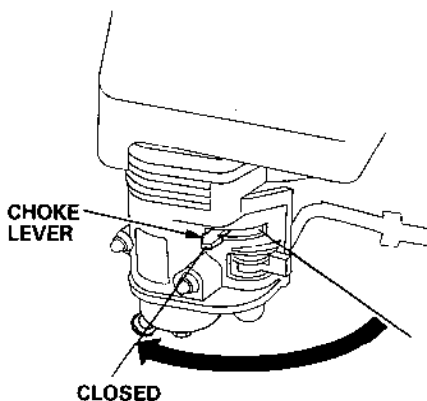

4. Move the throttle lever to the position marked with a dot (●).

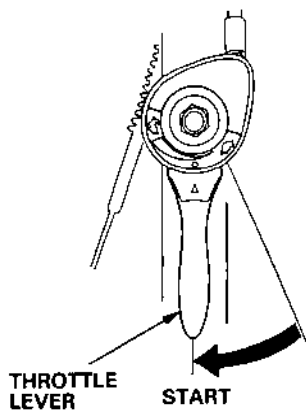

5. Pull the starter grip lightly until resistance is felt, then pull briskly.

NOTICE

Do not allow the starter grip to snap back against the engine. Return it gently to prevent damage to the starter.

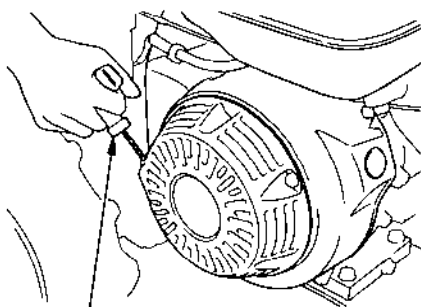

STARTER GRIP

6. If the choke lever has been turned to the CLOSED position to start the engine, turn it to the OPEN position as soon as the engine warms up enough to run smoothly.

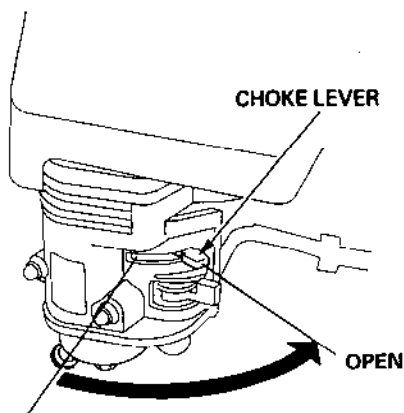

CLEARING A FLOODED ENGINE

If the engine won't start after you have operated the starter several times, the engine may be flooded with excess fuel. Use the following procedure to clear and start a flooded engine:

1. Turn the engine switch to the OFF position.
2. Remove the spark plug, dry it, then reinstall it.

NOTE:

Install the spark plug carefully, by hand, to avoid cross-threading. After the spark plug is seated, tighten $1/8$ to $1/4$ turn with a spark plug wrench to compress the washer.

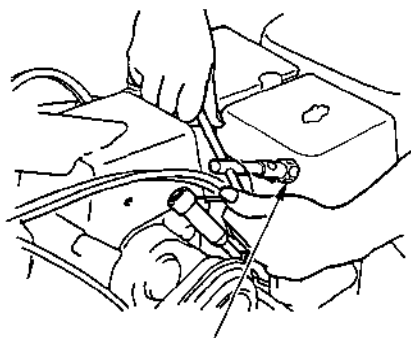

13/16 inch SPARK PLUG WRENCH

3. Turn the engine switch to the ON position.
4. Move the throttle lever to the FAST (←) position.
5. Turn the choke lever to the ~~CLOSED~~ position.

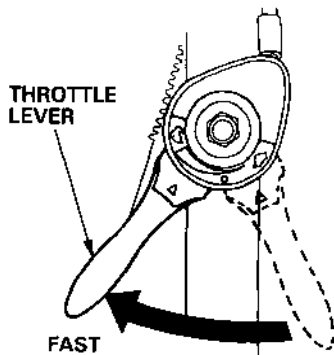

6. Pull the starter grip lightly until you feel resistance, then pull briskly. Return the starter grip gently; don't let it snap back against the engine.

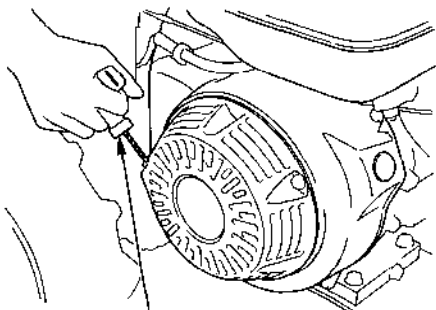

STARTER GRIP

5. TILLER OPERATION

BEFORE ADJUSTING THE HANDLEBAR, BE SURE THE ENGINE IS OFF.

HANDLEBAR HEIGHT ADJUSTMENT

NOTICE

Before adjusting the handlebar, place the tiller on firm level ground to prevent the handle from collapsing accidentally.

Stop the engine before adjusting handlebar height.

To adjust handlebar height, loosen the adjuster knob, select the appropriate holes in the handle column and handlebar bracket, and tighten the knob.

HEIGHT ADJUSTER KNOB

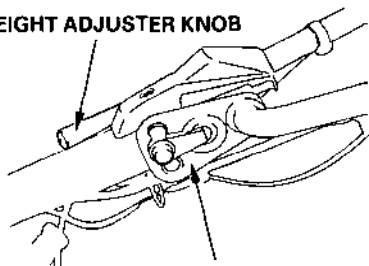

HANDLEBAR BRACKET

TILLING DEPTH ADJUSTMENT

BEFORE ADJUSTING THE TILLING DEPTH, BE SURE THE ENGINE IS OFF.

Tilling depth can be adjusted by removing the retainer and sliding the drag bar up or down as necessary.

If breaking ground for the first time, lower the drag bar all the way. As the soil becomes softer, the drag bar can be raised.

If not sure about soil conditions, start with the drag bar in the lowest position (see **HANDLING TIPS**, on page 23).

DRAG BAR

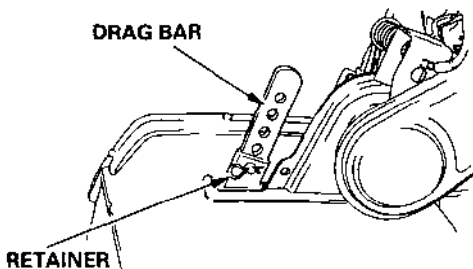

RETAINER

MAIN CLUTCH OPERATION

The main clutch disengages and engages the power from the engine to the transmission.

Push the clutch lever down against the handlebar to engage the main clutch.

Release the lever to disengage the main clutch.

MAIN CLUTCH LEVER

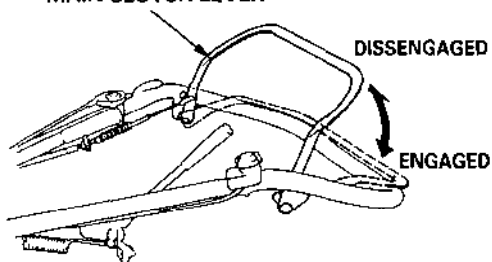

GEAR SELECTION

The transmission has three forward speeds, neutral, and reverse. The gear shift pattern is marked on the shift gate, at the base of the gear shift lever.

Release the main clutch lever before operating the gear shift lever.

Select one of the forward speeds; 1 or 2 for tilling, or 3 for propelling the tiller to and from the work area.

Select neutral (N) to move the tiller when the engine is not running.

NOTE:

Do not select neutral for tilling. The tines and wheels must both be driven for good tilling control. Wheel traction helps to prevent the tiller from surging forward when the tines hit hard ground.

Select reverse (R) to maneuver the tiller backward. The tine clutch lever must be in the DISENGAGE position before you can move the gear shift lever into reverse.

Avoid using excessive force on the gear shift lever. If gear engagement is difficult, push and release the main clutch lever to move the tiller slightly; this will reposition the gears to facilitate engagement.

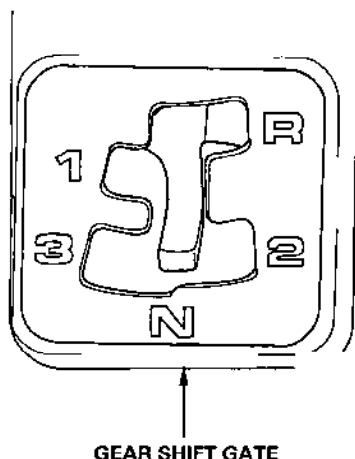
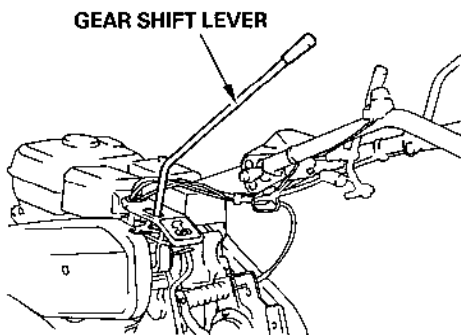

TINE CLUTCH OPERATION

The tine clutch engages and disengages the tine drive.

Release the main clutch lever before operating the tine clutch lever.

Move the tine clutch lever forward to engage the tine drive for tilling. The tines will start to rotate when you push the main clutch lever down against the handlebar. The tines will stop when you release the main clutch lever.

Move the tine clutch lever back to disengage the tine drive for propelling the tiller to and from the work area ; the tines will not rotate when the main clutch is operated.

Engage the tine clutch with the transmission in any forward gear (1, 2, 3).

Do not engage the tine clutch with the transmission in neutral (N). The tines and wheels must both be driven for good tilling control. Wheel traction helps to prevent the tiller from surging forward when the tines hit hard ground.

The tine clutch lever cannot be moved to the engaged position while the gear shift lever is in reverse (R).

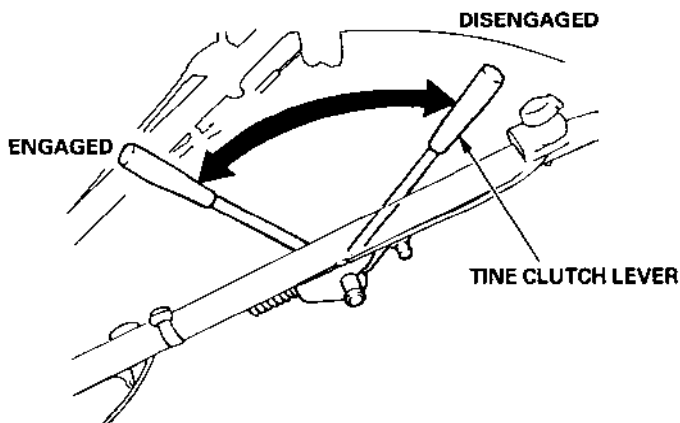

HANDLING TIPS

- Adjust the handlebar height to a comfortable position (waist height for normal tilling).
- The drag bar should always be used when tilling. It enables you to compensate for the hardness of the soil. The ideal height of the drag bar will depend on the type of soil being tilled and soil conditions at the time of tilling. In general, however, the drag bar should be adjusted so that the tiller is tilted slightly backward.
- If the machine jerks forward while tilling, press down on the handlebars. This will cause the drag bar to dig more deeply into the soil.
- If tines dig in but the machine will not move forward, move the handlebars from side to side.
- When turning, push down on the handlebars to bring the tiller's weight to the rear; this will make turning easier.
- Stop the tines before crossing gravel drives, walks, or roads. Stay alert for hidden hazards or traffic.
- Stop the engine immediately if the tiller vibrates abnormally. Check the tiller for damage or loose parts, and repair or replace them before using the tiller again. Vibration is usually a sign of trouble.

• HIGH ALTITUDE OPERATION

At high altitude, the standard carburetor air-fuel mixture will be too rich. Performance will decrease, and fuel consumption will increase. A very rich mixture will also foul the spark plug and cause hard starting.

High altitude performance can be improved by specific modifications to the carburetor. If you always operate your engine at altitudes above 1,500 meters (5,000 feet), have your servicing dealer perform this carburetor modification.

Even with carburetor modification, engine horsepower will decrease about 3.5% for each 300-meter (1,000-foot) increase in altitude. The effect of altitude on horsepower will be greater than this if no carburetor modification is made.

NOTICE

When the carburetor has been modified for high altitude operation, the air-fuel mixture will be too lean for low altitude use. Operation at altitudes below 1,500 meters (5,000 feet) with a modified carburetor may cause the engine to overheat and result in serious engine damage. For use at low altitudes, have your servicing dealer return the carburetor to original factory specifications.

6. STOPPING THE ENGINE

To stop the engine in an emergency, release the main clutch lever and turn the engine switch to the OFF position. To stop the engine under normal conditions, use the following steps.

1. Release the main clutch lever.

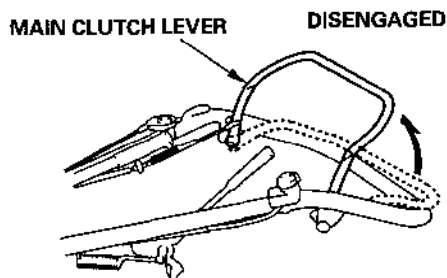

2. Move the throttle lever to the idle (↶) position.

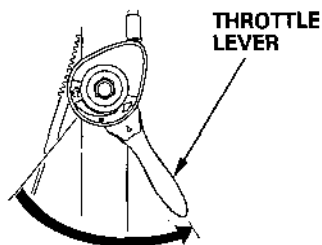

3. Turn the engine switch to the OFF position.

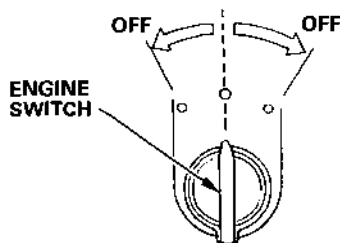

4. Turn the fuel valve to the OFF position.

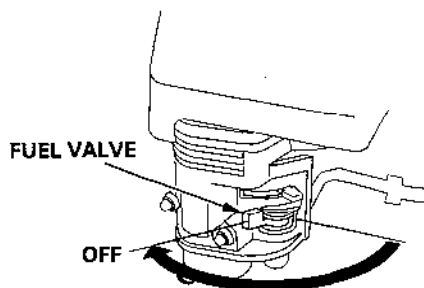

7. MAINTENANCE

THE IMPORTANCE OF MAINTENANCE

Good maintenance is essential for safe, economical, and trouble-free operation. It will also help reduce air pollution.

▲WARNING

Improperly maintaining this tiller, or failure to correct a problem before operation, can cause a malfunction in which you can be seriously hurt or killed.

Always follow the inspection and maintenance recommendations and schedules in this owner's manual.

To help you properly care for your tiller, the following pages include a maintenance schedule, routine inspection procedures, and simple maintenance procedures using basic hand tools. Other service tasks that are more difficult, or require special tools, are best handled by professionals and are normally performed by a Honda technician or other qualified mechanic.

The maintenance schedule applies to normal operating conditions. If you operate your tiller under severe conditions, such as sustained high-load or high-temperature operation, or use in unusually wet or dusty conditions, consult your servicing dealer for recommendations applicable to your individual needs and use.

Remember that your servicing dealer knows your tiller best and is fully equipped to maintain and repair it.

To ensure the best quality and reliability, use only new, genuine Honda parts or their equivalents for repair or replacement.

Maintenance, replacement, or repair of the emission control devices and systems may be performed by any engine repair establishment or individual, using parts that are "certified" to EPA standards.

MAINTENANCE SAFETY

Some of the most important safety precautions follow. However, we cannot warn you of every conceivable hazard that can arise in performing maintenance. Only you can decide whether or not you should perform a given task.

▲WARNING

Failure to properly follow maintenance instructions and precautions can cause you to be seriously hurt or killed.

Always follow the procedures and precautions in the owner's manual.

Safety precautions

- Make sure the engine is off before you begin any maintenance or repairs. This will eliminate several potential hazards:
 - **Carbon monoxide poisoning from engine exhaust.**
Be sure there is adequate ventilation whenever you operate the engine.
 - **Burns from hot parts.**
Let the engine and exhaust system cool before touching.
 - **Injury from moving parts.**
Do not run the engine unless instructed to do so.
- Read the instructions before you begin, and make sure you have the tools and skills required.
- To reduce the possibility of fire or explosion, be careful when working around gasoline. Use only a nonflammable solvent, not gasoline, to clean parts. Keep cigarettes, sparks, and flames away from all fuel-related parts.

EMISSION CONTROL SYSTEM INFORMATION

Source of Emissions

The combustion process produces carbon monoxide, oxides of nitrogen, and hydrocarbons. Control of hydrocarbons and oxides of nitrogen is very important because, under certain conditions, they react to form photochemical smog when subjected to sunlight. Carbon monoxide does not react in the same way, but it is toxic.

Honda utilizes lean carburetor settings and other systems to reduce the emissions of carbon monoxide, oxides of nitrogen, and hydrocarbons.

The U.S. and California Clean Air Acts

EPA and California regulations require all manufacturers to furnish written instructions describing the operation and maintenance of emission control systems.

The following instructions and procedures must be followed in order to keep the emissions from your Honda engine within the emission standards.

Tampering and Altering

Tampering with or altering the emission control system may increase emissions beyond the legal limit. Among those acts that constitute tampering are:

- Removal or alteration of any part of the intake, fuel, or exhaust systems.
- Altering or defeating the governor linkage or speed-adjusting mechanism to cause the engine to operate outside its design parameters.

Problems That May Affect Emissions

If you are aware of any of the following symptoms, have your engine inspected and repaired by your servicing dealer.

- Hard starting or stalling after starting.
- Rough idle.
- Misfiring or backfiring under load.
- Afterburning (backfiring).
- Black exhaust smoke or high fuel consumption.

Replacement Parts

The emission control systems on your Honda engine were designed, built, and certified to conform with EPA and California emission regulations. We recommend the use of genuine Honda parts whenever you have maintenance done. These original-design replacement parts are manufactured to the same standards as the original parts, so you can be confident of their performance. The use of replacement parts that are not of the original design and quality may impair the effectiveness of your emission control system.

A manufacturer of an aftermarket part assumes the responsibility that the part will not adversely affect emission performance. The manufacturer or rebuilder of the part must certify that use of the part will not result in a failure of the engine to comply with emission regulations.

Maintenance

Follow the maintenance schedule on page 31 . Remember that this schedule is based on the assumption that your machine will be used for its designed purpose. Sustained high-load or high-temperature operation, or use in unusually wet or dusty conditions, will require more frequent service.

AIR INDEX

An Air Index Information hang tag/label was applied to this engine in accordance with the requirements of the California Air Resources Board.

The bar graph is intended to provide you, our customer, the ability to compare the emissions performance of available engines. The lower the Air Index, the less pollution.

The durability description is intended to provide you with information relating to the engine's emission durability period. The descriptive term indicates the useful-life period for the engine's emission control system. See your *Emission Control Warranty* for additional information.

Descriptive Term	Applicable to Emissions Durability Period
Moderate	50 hours (0 – 65 cc) 125 hours (greater than 65 cc)
Intermediate	125 hours (0 – 65 cc) 250 hours (greater than 65 cc)
Extended	300 hours (0 – 65 cc) 500 hours (greater than 65 cc)

The Air Index Information hang tag must remain on the tiller until it is sold. Remove the hang tag before operating the tiller.

MAINTENANCE SCHEDULE

REGULAR SERVICE PERIOD (3) Perform at every indicated ITEM month or operating inter- val, whichever comes first.		Before each use	FIRST MONTH OR 20 hrs.	EVERY 3 MONTHS OR 50 hrs.	EVERY 6 MONTHS OR 100 hrs.	EVERY YEAR OR 300 hrs.
• Engine oil	Check	○				
	Replace		○		○	
Transmission oil	Check level	○				
Lower chain case oil	Check level	○				
• Air filter	Check	○				
	Clean			○ (1)		
	Replace					○*
Upper chain	Adjust-Grease			○		
Main clutch cable	Adjust		○		○	
Tine clutch cable	Adjust		○		○	
Belt tension	Adjust		○		○	
• Spark plug	Check-Adjust				○	
	Replace					○
• Sediment cup	Clean				○	
Spark arrester (Optional)	Clean				○	
Throttle cable	Adjust					○
• Idle speed	Check-Adjust					○ (2)
• Valve clearance	Check-Adjust					○ (2)
• Combustion chamber	Clean		After every 500 hrs. (2)			
Fuel tank & filter	Clean				○ (2)	
• All fasteners (for tightness)	Check-Tighten	Initial 10 hrs				
	Fuel tube	Check	Every 2 years (Replace if necessary)(2)			

NOTE: • Emission related items.

*Replace the paper element only.

(1) Service more frequently when used in dusty areas.

(2) These items should be serviced by an authorized Honda tiller dealer, unless you have the proper tools and are mechanically proficient. Refer to the Honda shop manual.

(3) For professional commercial use, log hours of operation to determine proper maintenance intervals.

ENGINE OIL CHANGE

Drain the oil while the engine is warm to assure rapid and complete draining.

1. Place a suitable container in front of the tiller to catch the used oil.
2. Remove the oil filler cap/dipstick and drain bolt.
3. Tilt the tiller forward and allow all of the oil to drain.
4. Reinstall and tighten the oil drain bolt. Refill with the recommended oil (page 11) to the top of the oil filler neck.

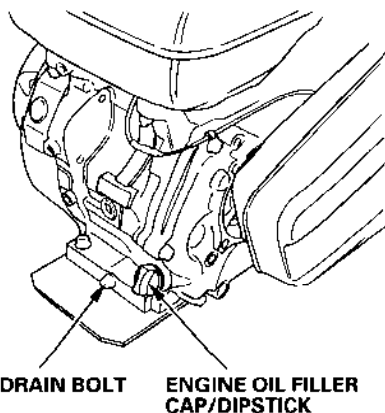

OIL CAPACITY: FR600: 0.6 US qt (0.6 ℓ , 0.5 Imp qt)
FR800: 1.2 US qt (1.1 ℓ , 1.0 Imp qt)

5. Reinstall the oil filler cap/dipstick.

Wash your hands with soap and water after handling used oil.

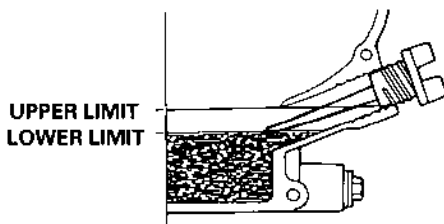

Please dispose of used motor oil and containers in a manner that is compatible with the environment. We suggest you take used oil in a sealed container to your local service station for reclamation. Do not throw it in the trash or pour it on the ground.

NOTICE

Running the engine with a low oil level will cause serious engine damage.

TRANSMISSION OIL CHANGE

Drain the oil while the engine is warm to assure rapid and complete draining.

1. Place a suitable container under the transmission to catch the used oil.
2. Remove the oil filler cap and the drain bolt to drain the used oil.
3. Reinstall the drain bolt and fill the transmission case up to the tip of the filler cap/dipstick with the recommended oil (See page 11).

OIL CAPACITY:

2.5 US qt (2.4 ℓ , 2.1 Imp qt)

4. Reinstall and tighten the filler cap.

Wash your hands with soap and water after handling used oil.

Please dispose of used motor oil and containers in a manner that is compatible with the environment. We suggest you take used oil in a sealed container to your local service station for reclamation. Do not throw it in the trash or pour it on the ground.

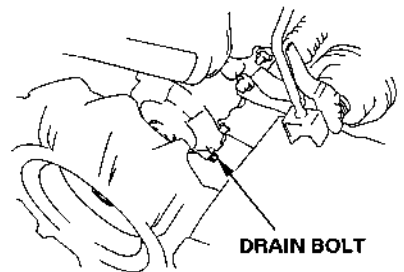
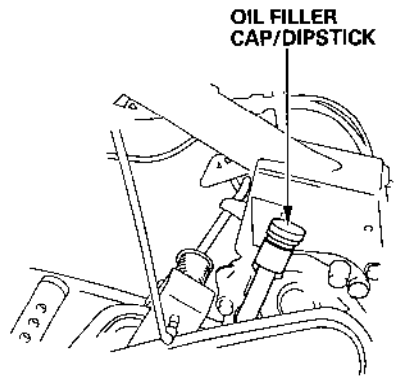

AIR FILTER SERVICE

A dirty air filter will restrict air flow to the carburetor. To prevent carburetor malfunction, service the air cleaner regularly. Service more frequently when operating the engine in extremely dusty areas.

NOTICE

Never run the engine without the air filter. Rapid engine wear will result.

1. Remove the cover wing nut, then remove the air cleaner cover.
2. Remove the filter wing nut, then remove and separate the air filter elements. Carefully check both elements for holes or tears, and replace the filter if damaged.
3. Foam element: Clean in warm soapy water, rinse and allow to dry thoroughly. Or clean in nonflammable solvent and allow to dry. Dip the element in clean engine oil and squeeze out all excess oil. The engine will smoke during initial running if too much oil is left in the foam.

▲WARNING

Using gasoline or flammable solvent to clean the filter element can lead to a fire or explosion. Use only soapy water or nonflammable solvent.

4. Paper element: Tap the element several times on a hard surface to remove excess dirt, or blow compressed air [not exceeding 30 psi (207 kPa, 2.1 kg/cm²)] through the filter from the inside. Never try to brush the dirt off; brushing will force dirt into the fibers.
5. Wipe dirt from the inside of the air cleaner housing and cover, using a moist rag. Be careful to avoid dropping dirt into the air cleaner duct that leads to the carburetor.
6. Reinstall the air filter and cover.

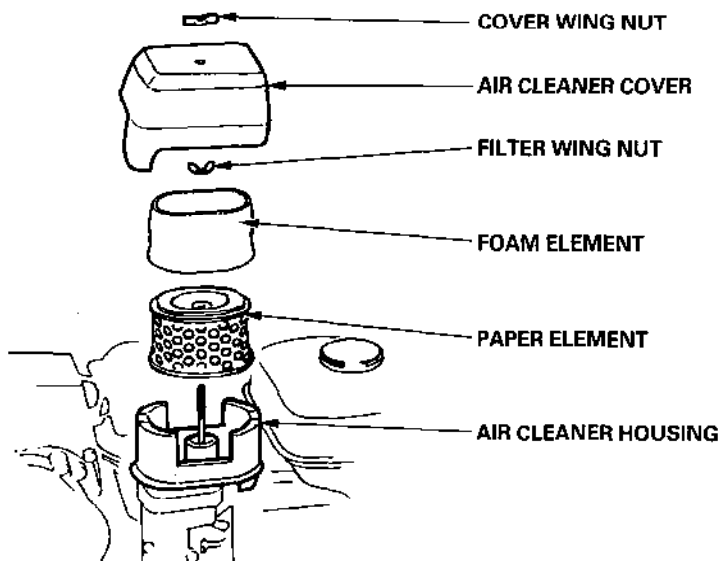

FASTENER TIGHTNESS CHECK

Check to be sure all the fasteners are tight. If not, retighten them. Tightening points are as follows:

- Upper chain case to rotary case
- Transmission to rotary frame
- Rotary cover to rotary frame
- Swing base to transmission

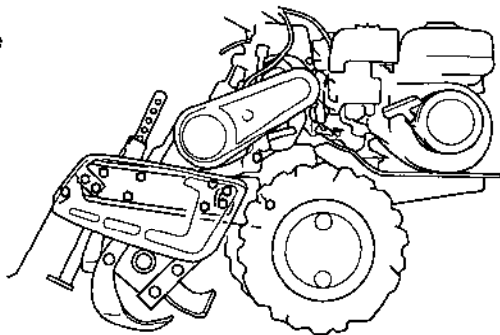

SPARK PLUG SERVICE

Recommended spark plug: BPR6ES (NGK),
W20EPR-U (DENSO)

NOTICE

An incorrect spark plug can cause engine damage.

1. Clean any dirt from around the spark plug base.
2. Remove the spark plug cap.
Use a 13/16 inch spark plug wrench to remove the spark plug.
3. Inspect the spark plug. Replace it if the electrodes are worn, or if the insulator is cracked or chipped. Clean the spark plug with a wire brush if you are going to reuse it.
4. Measure the spark plug electrode gap with a suitable gauge. The gap should be 0.028 – 0.031 in (0.70 – 0.80 mm).
Correct the gap, if necessary, by carefully bending the side electrode.
5. Install the spark plug carefully, by hand, to avoid cross-threading.
6. After the spark plug is seated, tighten with a 13/16 inch spark plug wrench to compress the washer.

NOTICE

**A loose spark plug can overheat and damage the engine.
Overtightening the spark plug can damage the threads in the cylinder head.**

If installing a new spark plug, tighten 1/2 turn after the spark plug seats to compress the washer. If reinstalling a used spark plug, tighten 1/8 – 1/4 turn after the spark plug seats.

7. Install the spark plug cap on the spark plug.

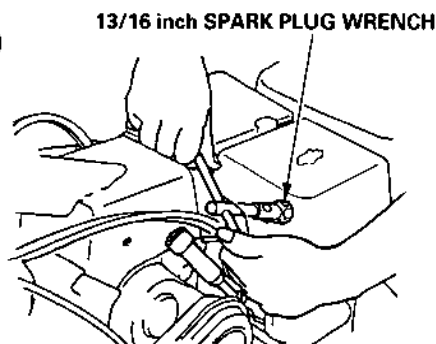
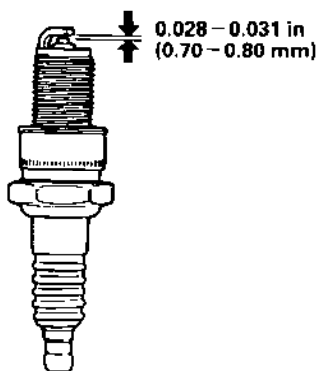

SPARK ARRESTER SERVICE (optional part)

Your engine is not factory-equipped with a spark arrester. In some areas, it is illegal to operate an engine without a spark arrester. Check local laws and regulations. A spark arrester is available from authorized Honda servicing dealers.

The spark arrester must be serviced every 100 hours to keep it functioning as designed.

If the engine has been running, the muffler will be very hot. Allow the muffler to cool before servicing the spark arrester.

1. Remove the two 8 mm nuts ① and remove the muffler from the cylinder.
2. Remove the three 4 mm screws ② from the exhaust deflector ③, and remove the deflector.
3. Remove the four 5 mm screws ④ from the muffler protector ⑤, and remove the muffler protector.
4. Remove the 4 mm screw ⑥ from the spark arrester ⑦, and remove the spark arrester from the muffler ⑧.

(FR600)

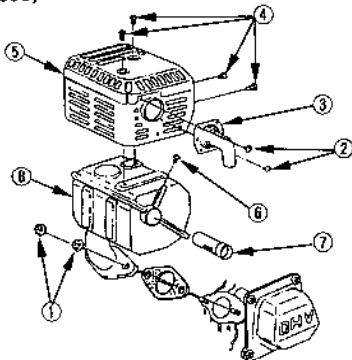

(FR800)

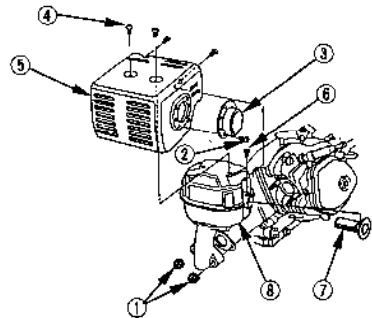

5. Use a brush to remove carbon deposits from the spark arrester screen. Be careful to avoid damaging the screen.

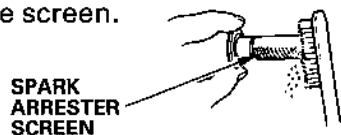

The spark arrester screen must be free of breaks and holes. Replace the spark arrester if it is damaged.

6. Install the spark arrester and the muffler in the reverse order of disassembly.

SEDIMENT CUP CLEANING

1. Turn the fuel valve to the OFF position.
2. Remove the sediment cup with a 10 mm wrench.
3. Empty the sediment cup, and wash it in nonflammable solvent.
4. Inspect and reinstall the O-ring. Replace the O-ring if it is damaged.
5. Install the sediment cup, and tighten it securely.
6. Turn the fuel valve to the ON position, and check for leaks.

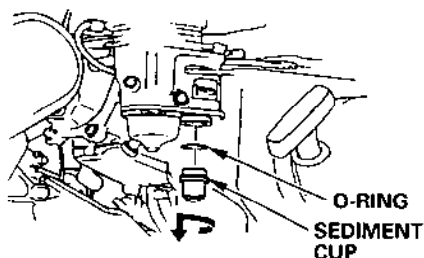

▲WARNING

Gasoline is extremely flammable, and gasoline vapor can explode. Turn the fuel valve to the OFF position after servicing the sediment cup. Wipe up any spilled fuel.

MAIN CLUTCH CABLE ADJUSTMENT

Correct main clutch cable adjustment is important for tiller performance and drive belt service life. Misadjustment can cause drive belt slippage with resultant loss of power and premature belt wear.

1. Measure free play at the top of the lever.

Free play should be:
3/16–3/8 in (5.0–10.0 mm)

2. If adjustment is necessary, loosen the lock nuts with a 12 mm wrench, and move the adjuster by turning both nuts.
3. Tighten the lock nuts and recheck free play.

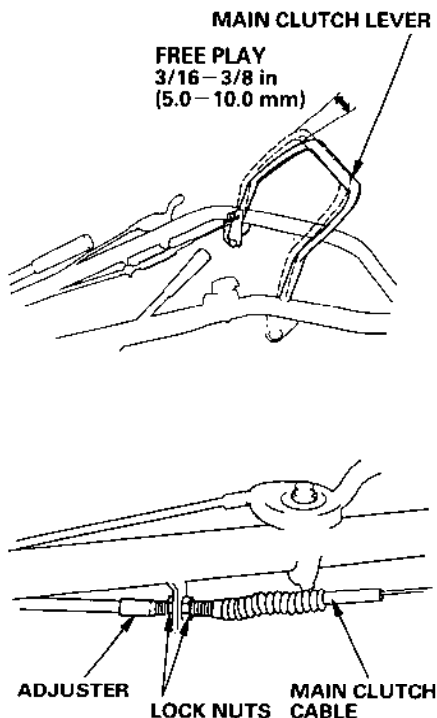

TINE CLUTCH CABLE ADJUSTMENT

1. With the tine clutch lever in the **DISENGAGE** position, measure free play at the tip of the lever.

Free play should be:

0 – 1/25 in (0 – 1.0 mm)

Just enough to ensure that the cable does not remain under tension in the **DISENGAGE** position.

2. If adjustment is necessary, loosen the lock nuts with a 12 mm wrench, and move the adjuster by turning both nuts.
3. Tighten the lock nuts and recheck free play.

FREE PLAY
0 – 1/25 in (0 – 1.0 mm)

TINE CLUTCH LEVER

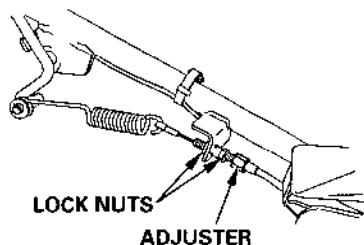
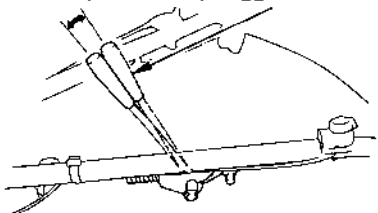

THROTTLE CABLE ADJUSTMENT

1. With the throttle lever in the **idle** (↶) position, measure free play at the tip of the lever.

You can feel the free play, if you loosen the throttle lever tension bolt on top of the throttle lever housing. Or, you can determine free play by watching for throttle arm movement at the carburetor.

FREE PLAY
3/16 – 3/8 in (5.0 – 10.0 mm)

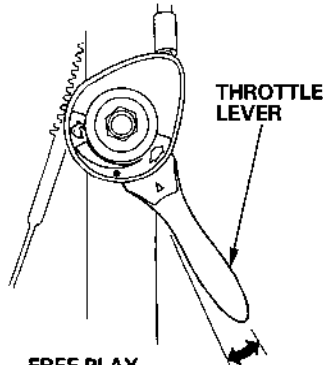

2. If adjustment is necessary, hold one of the cable adjusters with an 8 mm wrench, and loosen the lock nut with a 10 mm wrench. Turn the adjusters to obtain the correct free play.

3. Tighten the lock nut and recheck free play.

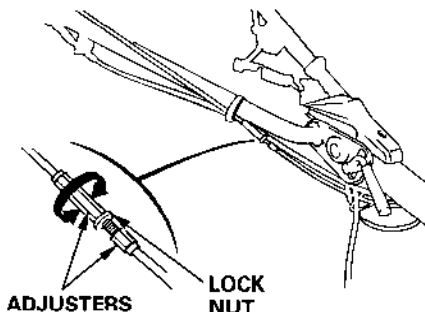

DRIVE BELT ADJUSTMENT

Correct drive belt tension is important for tiller performance and belt service life. A slipping belt will cause loss of power and premature belt wear.

1. Adjust the main clutch cable (page 38).
2. Remove the belt cover.
3. With the main clutch lever in the ENGAGED position, check the distance between the upper and lower sections of the drive belt at the belt tensioner.
4. If adjustment is necessary, loosen the engine and engine stay mounting bolts and move the engine back and forth until the correct distance is obtained.
5. After adjusting the distance, tighten the engine and engine stay mounting bolts securely.

FR600: V-belt (SB40)

FR800: V-belt (SB44)

NOTE:

Align the surface of the drive pulley with the surface of the driven pulley when adjusting the belt tension.

6. Adjust the belt-to-belt stopper clearances as shown.

	FR800		FR600
(A)	0.04 – 0.12 in (1.0 – 3.0 mm)	(C)	0.12 – 0.16 in (3.0 – 4.0 mm)
(B)	0.12 – 0.20 in (3.0 – 5.0 mm)	(D)	0.08 – 0.16 in (2.0 – 4.0 mm)

7. To adjust, loosen the stopper mounting bolt and move the stopper up or down as necessary.
8. After adjusting the clearance, tighten the stopper mounting bolt securely.
9. Reinstall the belt cover.

FR600: 2.6 – 2.8 in (65 – 70 mm)

FR800: 2.0 – 2.2 in (52 – 57 mm)

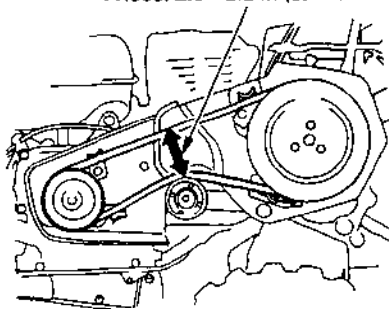

ENGINE STAY
MOUNTING BOLT

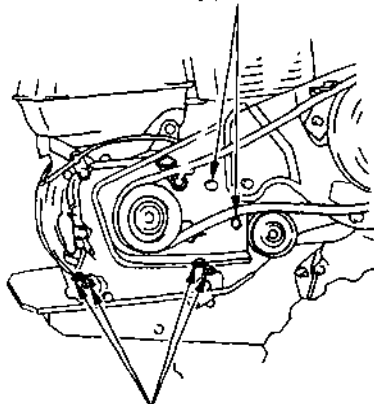

ENGINE MOUNTING
BOLT

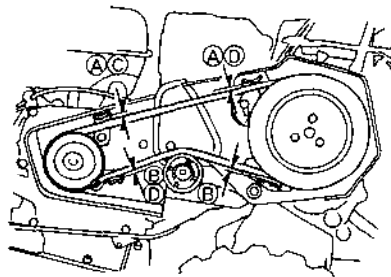

▲WARNING

After adjustment, be sure to reinstall the belt cover. Failure to follow this instruction may cause your clothing to be caught in moving parts, resulting in serious accident or injury.

UPPER CHAIN ADJUSTMENT

1. Remove the primary chain case cover.
2. Check chain slack midway between the sprockets;
It should be:
0.20–0.59 in (5.0–15.0 mm)
To adjust tension, loosen the tensioner adjusting bolts and move the tensioner up or down as necessary.
3. Grease the chain.

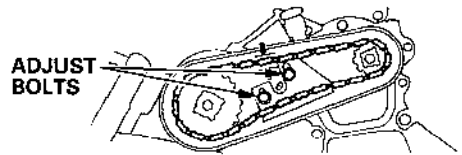

TINE REPLACEMENT

Use genuine Honda replacement tines or their equivalent. Wear heavy gloves to protect your hands.

Nut and bolt positions

For rotary tines A/B and E'/F':

Tighten the bolts from outside in.

Make sure to install the tine plates.

For other tines: Tighten the bolts from inside out.

Tine positions

Rotary tines C/D and C'/D':

Toward outside

Others: Toward inside

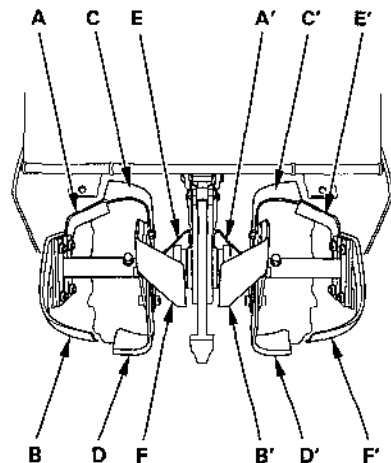
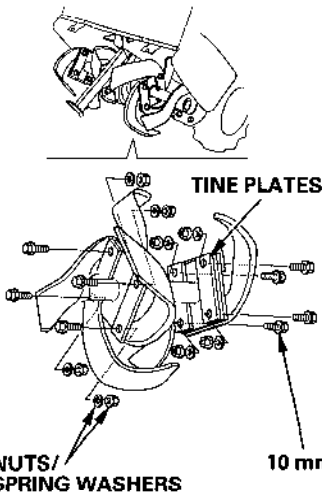

8. TRANSPORTING/STORAGE

If the tiller has been running, allow the engine to cool for at least 15 minutes before loading the tiller on the transport vehicle or placing it in storage. A hot engine and exhaust system can burn you and can ignite some materials.

▲WARNING

When transporting or storing the tiller, keep the tiller level to prevent fuel spillage. Fuel vapor or spilled fuel may ignite.

Before Loading

Turn the fuel valve to the OFF position. This will prevent the possibility of carburetor flooding and will reduce the possibility of fuel leakage.

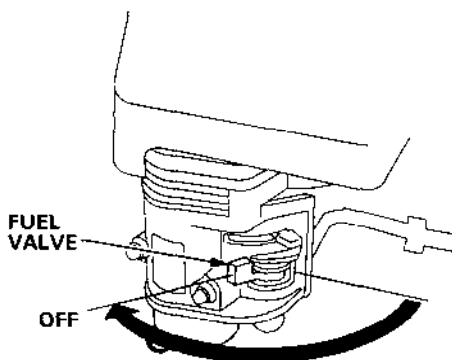

Loading/Unloading

To reduce the possibility of fuel leakage, keep the tiller level while transporting, and avoid tilting the tiller excessively when loading and unloading.

- If a suitable loading ramp is not available, two people should lift the tiller on and off the vehicle, while holding the tiller level.
- Position the tiller so the tines and wheels are on the bed of the vehicle. Tie the tiller down with rope or straps, and block the wheels. Keep the tie-down rope or straps away from controls, cables, governor linkage, carburetor, and the fuel line.

PREPARATION FOR STORAGE

When the tiller will not be used for one month or longer, proper storage preparation will help to prevent rust and corrosion, and will make it easier to start the engine when the tiller is removed from storage.

1. Clean all surfaces of the tiller, including the area underneath the tine cover. Wear heavy gloves to protect your hands.

If you use a garden hose to wash the tiller, observe the following precautions:

- If the tiller has been running, allow the engine to cool for at least half an hour before spraying water on it. Never spray water on a hot engine.
 - Wash the tiller using low water pressure, and keep water away from controls, cable ends, and all other places that are difficult to dry if water enters.
 - After washing, start the engine outdoors, and let it run until it reaches normal operating temperature to evaporate any water remaining on the engine.
 - Stop the engine, turn the fuel valve OFF, and allow the engine to cool before placing the tiller in storage.
2. Coat areas that may rust with a light film of oil. Lubricate all control cable cores with a silicone spray lubricant.

For storage of a month or longer, perform these additional steps:

3. Fill the fuel tank with fresh gasoline, and add a gasoline conditioner, such as HONDA FUEL STABILIZER, which is formulated to extend fuel storage life.

Be sure the fuel tank is completely filled. If partially filled, air in the tank will promote fuel oxidation and deterioration, resulting in bad fuel that may cause hard starting. Deteriorated fuel may also clog carburetor passages, requiring carburetor repair or replacement.

Fuel oxidation problems can also be prevented by completely draining the fuel tank and carburetor. Carburetor draining is recommended if storage time will exceed two months. However, a drained fuel tank may rust from the effects of moisture condensation. It is best to leave the fuel tank completely filled, unless you are preparing the tiller for shipment or other special circumstances.

NOTE:

The Distributor's Limited Warranty does not cover fuel system damage of engine performance problems resulting from neglected storage preparation.

If storage time will not exceed two months, it is not necessary to drain the carburetor. Add gasoline conditioner before starting the engine (page 44, step 3) ; that will ensure that treated gasoline replaces the untreated gasoline in the carburetor.

For storage of two months or longer, perform these additional steps:

▲WARNING

When transporting or storing the tiller, turn the fuel valve OFF and keep the tiller level to prevent fuel spillage. Fuel vapor or spilled fuel may ignite.

Before storing the unit for an extended period;

4. Be sure the storage area is free of excessive humidity and dust.

Drain the fuel...

- a. With the fuel valve turned OFF, remove and empty the sediment cup.
- b. Turn the fuel valve ON and drain the gasoline in the fuel tank into a suitable container.

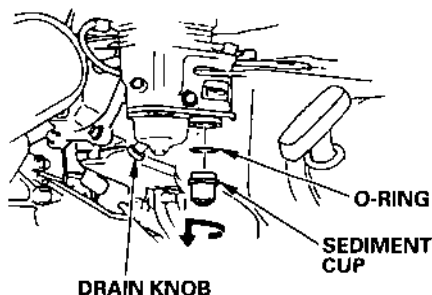

-
- c. Replace the sediment cup and tighten securely.
 - d. Drain the carburetor by loosening the drain knob.
Drain the gasoline into a suitable container. Tighten the drain Knob.

5. Change the engine oil (page 32).
6. Lubricate the piston and cylinder.
 - a. Remove the spark plug (page 36).
 - b. Pour a tablespoon of clean engine oil into the cylinder. Pull the starter grip several times to distribute the oil in the cylinder.
Reinstall the spark plug.

NOTE:

While the spark plug is removed, inspect the plug, and clean, gap, or replace it if necessary.

- c. Pull the starter grip until you feel resistance. This closes the valves, which helps to protect the cylinder from corrosion.

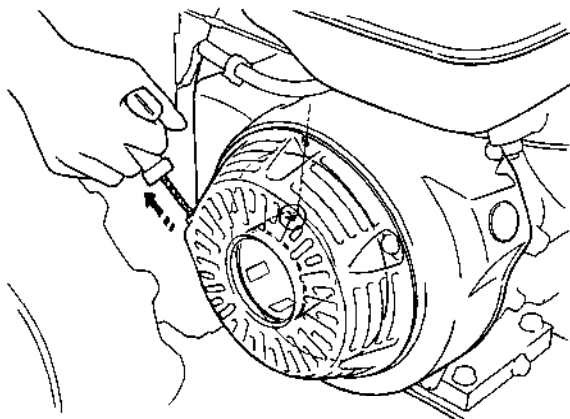

STORAGE

Select a storage area away from appliances (water heater or clothes dryer) that use an open flame as a heat source. Power tools, and some battery operated toys, have electric motors that produce sparks that can ignite gasoline vapors.

▲WARNING

Gasoline is highly flammable and explosive. You can be burned or seriously injured when handling fuel.

- **Keep heat, sparks, and flame away.**
- **Handle fuel only outdoors.**
- **Wipe up spills immediately.**

Avoid storing the tiller where it will be exposed to high humidity and dust.

Place the tiller with its tines and wheels on a level surface. Tilting the tiller may result in fuel leakage.

Cover the tiller to keep out dust.

NOTE:

Plastic sheets should not be used as dust covers; they trap moisture under the covers, promoting rust and corrosion.

REMOVAL FROM STORAGE

Check all items described in the PRE-OPERATION CHECK section of this manual (pages 11 – 16).

NOTE:

- Fill the fuel tank with fresh gasoline. If you keep a container of gasoline for refueling, be sure that it contains only fresh gasoline. Gasoline oxidizes and deteriorates over time, resulting in bad fuel that may cause hard starting.

▲WARNING

Gasoline is highly flammable and explosive. You can be burned or seriously injured when handling fuel.

- Keep heat, sparks, and flame away.
 - Handle fuel only outdoors.
 - Wipe up spills immediately.
-
- If the cylinder was coated with oil during storage preparation, the engine will smoke briefly at start up. This is normal.

9. TROUBLESHOOTING

When the engine will not start ;

1. Is there enough fuel?
2. Is the fuel valve ON?
3. Is the engine switch ON?
4. Is gasoline reaching the carburetor?

To check, loosen the drain knob with the fuel valve on. Fuel should flow out freely. Retighten drain knob.

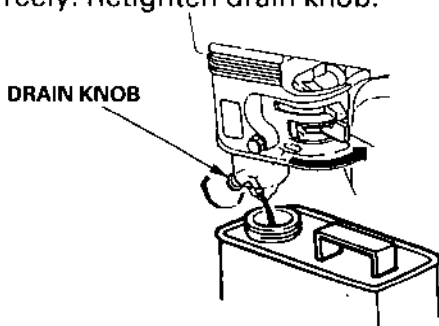

▲WARNING

If any fuel is spilled, make sure the area is dry before testing the spark plug or starting the engine. Spilled fuel or fuel vapor may ignite.

5. Is there a spark at the spark plug?
 - a. Remove the spark plug cap. Clean any dirt from around the spark plug base, then remove the spark plug.
 - b. Install the spark plug in the plug cap.
 - c. Turn the engine switch on.
 - d. Grounding the side electrode to any engine ground, pull the recoil starter to see if sparks jump across the gap.

▲WARNING

- **Never hold the spark plug lead with wet hands while performing this test.**
 - **Make sure that no fuel has been spilled on the engine and that the plug is not wet with fuel.**
 - **To avoid fire hazards, do not allow sparks near the plug hole.**
- e. If there is no spark, replace the plug.
If OK, try to start the engine according to the instructions.
6. If the engine still does not start, take the tiller to an authorized Honda dealer.

10. SPECIFICATIONS

Model	FR600	FR800
Dimensions, (Length)	57.5 in (1,460 mm)	55.9 in (1,420 mm)
(Height)	48.8 in (1,240 mm)	48.4 in (1,230 mm)
(Width)	22.0 in (560 mm)	27.8 in (705 mm)
Weight	207 lbs (94 kg)	278 lbs (126 kg)
Tire size	3.50-7	
Maximum handle height	47.8 in (1,215 mm)	

Engine

Model	FR600	FR800
Engine model	GX160 K1	GX240 K1
Type	Single cylinder, 4-stroke forced air cooled, overhead valve	
Displacement/ Bore and stroke	9.9 cu-in (163 cm ³) 2.7 × 1.8 in (68 × 45 mm)	14.8 cu-in (242 cm ³) 2.9 × 2.3 in (73 × 58 mm)
Ignition timing	20°BTDC, fixed	
Ignition system	Transistorized magneto	
Engine oil capacity	0.6 US qt (0.6 ℓ, 0.5 Imp qt)	1.2 US qt (1.1 ℓ, 1.0 Imp qt)
Fuel tank capacity	0.95 US gal (3.6 ℓ, 0.79 Imp gal)	1.59 US gal (6.0 ℓ, 1.32 Imp gal)
Spark plug	BPR6ES (NGK), W20EPR-U (DENSO)	
Main clutch	Belt tension	
Transmission	Three speeds forward and one reverse speed	
Transmission oil capacity	2.5 US qt (2.4 ℓ, 2.1 Imp qt)	

Tine assembly

Model	FR600	FR800
Tilling depth control	Adjustable drag bar	
Tine shaft speed	230 rpm	217 rpm
No. of tines	6 on each side	
Oil capacity	0.37 US qt (0.35 ℓ, 0.31 Imp qt)	

Tune-up Specifications

ITEM	SPECIFICATION	MAINTENANCE
Spark plug gap	0.028-0.031 in (0.70-0.80 mm)	Refer to page: 36
Valve clearance	IN: 0.15 ± 0.22 mm cold EX: 0.20 ± 0.02 mm cold	See your authorized Honda dealer
Other specification	No other adjustments needed.	

NOTE:

Specifications may vary according to the types, and are subject to change without notice.

11. WARRANTY SERVICE INFORMATION

Honda power equipment dealership personnel are trained professionals. They should be able to answer any question you may have. If you encounter a problem that your dealer does not solve to your satisfaction, please discuss it with the dealership's management. The Service Manager or General Manager can help. Almost all problems are solved in this way.

If you are dissatisfied with the decision made by the dealership's management, contact the Honda Power Equipment Customer Relations Office. You can write to:

American Honda Motor Co., Inc.
Power Equipment Division
Customer Relations Office
4900 Marconi Drive
Alpharetta, Georgia 30005-8847

Or telephone: (770) 497-6400

When you write or call, please give us this information:

- Model and serial number (see page 10)
- Name of dealer who sold the tiller to you
- Name and address of dealer who services your tiller
- Date of purchase
- Your name, address, and telephone number
- A detailed description of the problem

MEMO

HONDA

HONDA MOTOR CO., LTD. TOKYO, JAPAN

31770620
00X31-770-6200

EM3 (AH) (美) (C) (HC) 500.2000.10
PRINTED IN JAPAN