

HONDA

Power

Equipment

OWNER'S MANUAL

HT-R3811

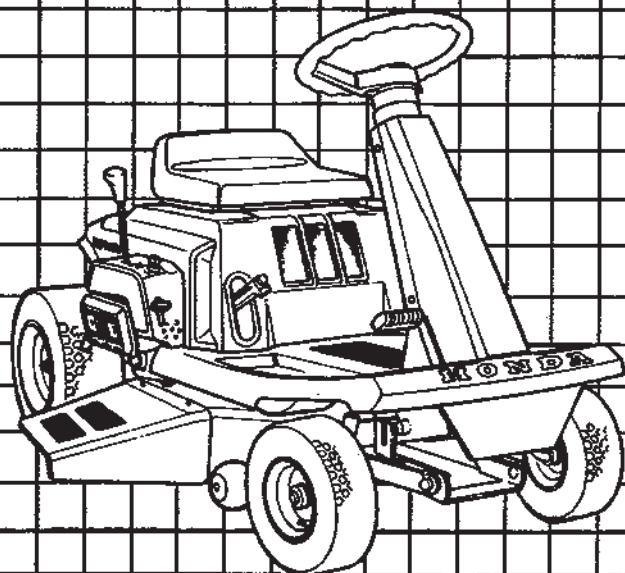

Thank you for purchasing a Honda riding mower.

This manual covers the operation and maintenance of the Honda HT-R3811 riding mower, type SA (side discharge).

Honda Motor Co., Ltd. reserves the right to make changes at any time without notice and without incurring any obligation.

No part of this publication may be reproduced without written permission.

This manual should be considered a permanent part of the riding mower and should remain with the riding mower when sold.

Pay special attention to statements preceded by the following words;

⚠ DANGER: Indicates severe personal injury or loss of life will result if instructions are not followed.

⚠ WARNING Indicates a strong possibility of severe personal injury or loss of life if instructions are not followed.

CAUTION: Indicates a possibility of personal injury or equipment damage if instructions are not followed.

NOTE: Gives helpful information.

⚠ WARNING

- Honda riding mowers are designed to give safe and dependable service if operated according to instructions.
- Read and understand this Owner's Manual before operating the riding mower. Failure to do so could result in personal injury or equipment damage.

If a problem should arise, or if you have any questions about the riding mower consult an authorized Honda riding mower dealer.

It is illegal in some areas to operate a gasoline engine without a U.S.D.A. qualified spark arrester; check local laws and regulations. You can purchase an optional spark arrester for this riding mower from your authorized Honda Power Equipment dealer.

HONDA MOTOR CO., LTD. 1986, ALL RIGHTS RESERVED

CONTENTS

1. SAFETY INSTRUCTIONS	3
2. COMPONENT IDENTIFICATION	7
3. CONTROLS	10
4. PRE-OPERATION CHECKS	15
5. OPERATION	23
• Starting the engine	23
• Mowing	26
• Stopping the engine	30
• High altitude operation	31
6. TRANSPORTING/STORAGE	32
7. MAINTENANCE	38
8. TROUBLESHOOTING	55
9. SPECIFICATIONS	58
10. WIRING DIAGRAM	59
11. WARRANTY SERVICE	60

1. SAFETY INSTRUCTIONS

WARNING LABEL LOCATIONS

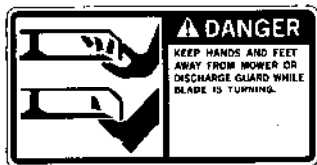
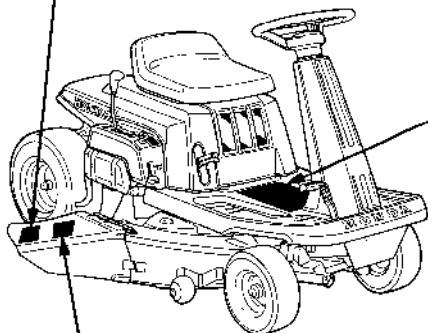

⚠ WARNING

- READ OWNER'S MANUAL BEFORE OPERATING.
- OPERATOR ONLY. DO NOT CARRY PASSENGERS.
- MAXIMUM SAFE OPERATING ANGLE 10 DEGREES. (17% GRADE)
- REDUCE SPEED WHEN TURNING OR OPERATING ON SLOPES.
- STOP ENGINE BEFORE REMOVING GRASS CATCHER OR CLEANING DISCHARGE CHUTE.
- KEEP ALL SHIELDS AND SAFETY DEVICES IN PLACE.
- KEEP PEOPLE AND PETS AT A SAFE DISTANCE WHILE OPERATING.
- THIS RIDING MOWER IS NOT LEGAL FOR USE ON PUBLIC STREETS OR HIGHWAYS.

OPERATION

STARTING ENGINE

- MOVE PTO LEVER TO "OFF"
- MOVE TRANSMISSION SHIFT LEVER TO "N"
- MOVE THROTTLE LEVER TO "START" (WHIRL)
- TURN IGNITION KEY TO "START" AND ALLOW ENGINE TO WARM UP
- SET THROTTLE LEVER BETWEEN ← AND →

OPERATING

- DEPRESS BRAKE AND SHIFT TRANSMISSION SHIFT LEVER TO DESIRED SPEED RANGE
- RELEASE BRAKE PEDAL TO START MOWER MOVING.
- RELEASE PARKING BRAKE.

STOPPING ENGINE

- MOVE PTO LEVER TO "OFF" AND TRANSMISSION SHIFT LEVER TO "N"
- SET PARKING BRAKE.
- TURN IGNITION KEY TO "OFF"

HINDA RUMIKI CO., LTD. MADE IN JAPAN

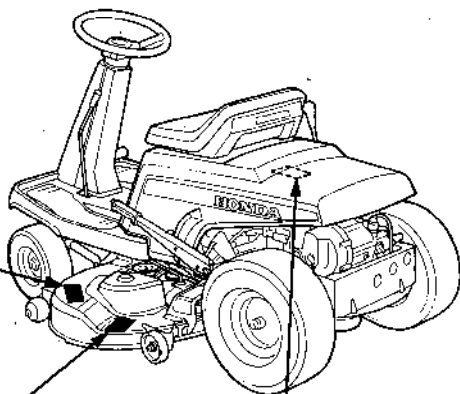

RIDING MOWER SAFETY

 **WARNING** Operating a riding mower requires special efforts on your part to ensure your safety and the safety of others. Know these requirements before you operate the riding mower.

SAFE OPERATING RULES

- Always make a pre-operation inspection (page 15) before you operate the riding mower; you may prevent an accident or equipment damage.
- All parts, especially guards and shields, should be in good condition, and securely fastened in place.
- Be sure all nuts, bolts and screws are tight; especially the blade mounting bolts.
- Do not remove any guards, warning labels, shields or safety devices; they are installed for your safety.
- Know how to stop the engine and blades quickly. Thoroughly understand operation of all controls.
- Never permit anyone to operate the riding mower without proper instructions.
- Do not allow passengers to ride on the mower or any of its attachments.
- Children should not be permitted to operate this riding mower.
- Because of the danger of carbon monoxide poisoning, do not run the engine indoors.
- To prevent serious injury, never put your hands or feet under the cutter deck.
- Do not operate the riding mower while barefoot. Wear sturdy shoes or boots and clothing that is not loose.

-
- Be alert. Do not operate the riding mower when you are tired, ill or under the influence of alcohol or drugs.
 - Mow only in daylight or good artificial light.
 - Watch out for and avoid rocks, roots, holes and other obstacles.
 - If you hit an object, stop and inspect the riding mower; fix any damage before you operate the mower again.
 - Replace damaged, worn or broken parts immediately.
 - Do not operate near the edge of a ditch or an embankment.

BEFORE MOWING

- Before mowing, always clear the lawn of stones, sticks and other debris. These objects could be thrown out by the spinning blades and cause an injury or equipment damage.
- Select a safe operating speed (gear position) for the area to be mowed. 5th gear should be used only while driving to and from the storage area.
- Always ensure that the area in front of and behind the riding mower is clear of people, pets and debris before starting.
- Be very careful when you operate the riding mower in Reverse.
- Do not mow in Reverse unless it is absolutely necessary.

OPERATION ON SLOPES

- This riding mower is intended for use on relatively flat terrain. Do not use on sloped surfaces exceeding 10 degrees (17% grade). This angle may be further reduced by the condition and type of surface.

Maximum safe operating angle

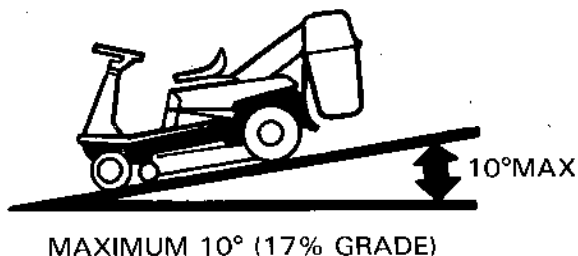

-
- If mowing on a sloping surface, always drive up and down the face of the grade. Never turn or drive across the face of the slope.
 - To prevent loss of control or overturning, always reduce speed and exercise extreme caution when operating on sloping or uneven surfaces.
 - Avoid turning or stopping on sloping surfaces; see page 28 for special instructions.
 - Do not back down or rapidly accelerate up a sloping surface; see page 28 for special instructions.
 - When mowing on slopes, empty the grass bags when they are half full. On a slope, the weight of full bags may cause the mower to tip over.

CLEANING AND STORAGE

- Leaves, grass clippings, oil and other combustible materials can become a fire hazard. Be sure to keep the engine compartment, the upper cutter deck surfaces and the belt and pulley areas clean.
- Stop the engine before removing the grass bags or cleaning the discharge chute.
- Check the condition of the grass catcher bags frequently. For your safety, replace any bag that is worn or deteriorated.
- Always empty the grass catcher bags when mowing is completed. Damp, decomposing grass clippings generate heat and can become a fire hazard.
- To reduce the possibility of fire, allow the engine and exhaust system to cool before storing the mower in an enclosed space or near combustible materials.

2. COMPONENT IDENTIFICATION

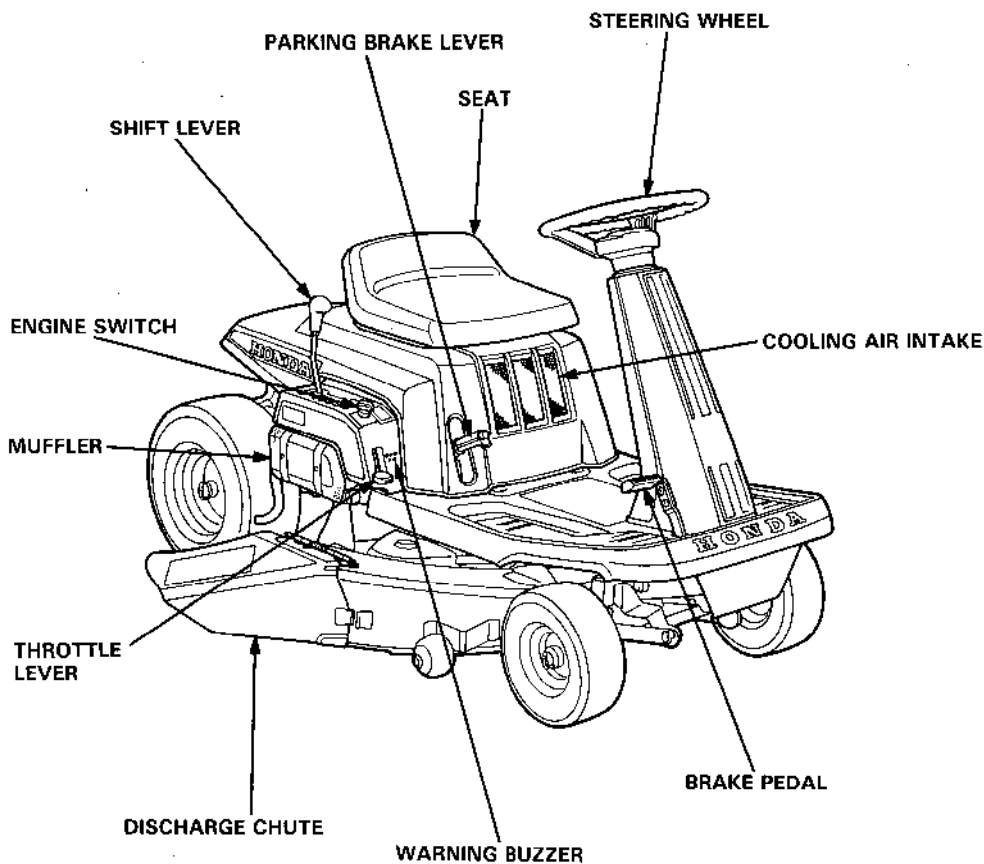

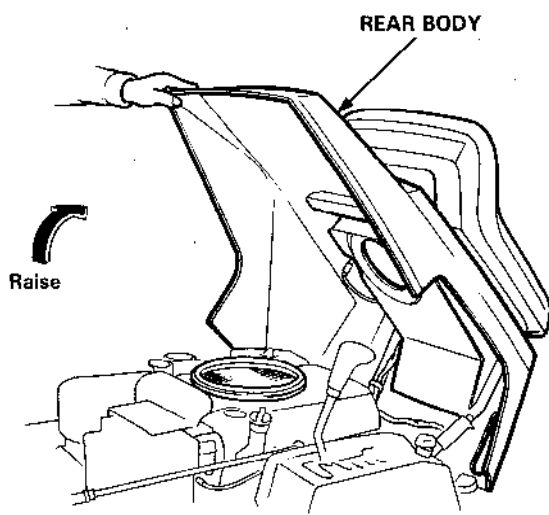
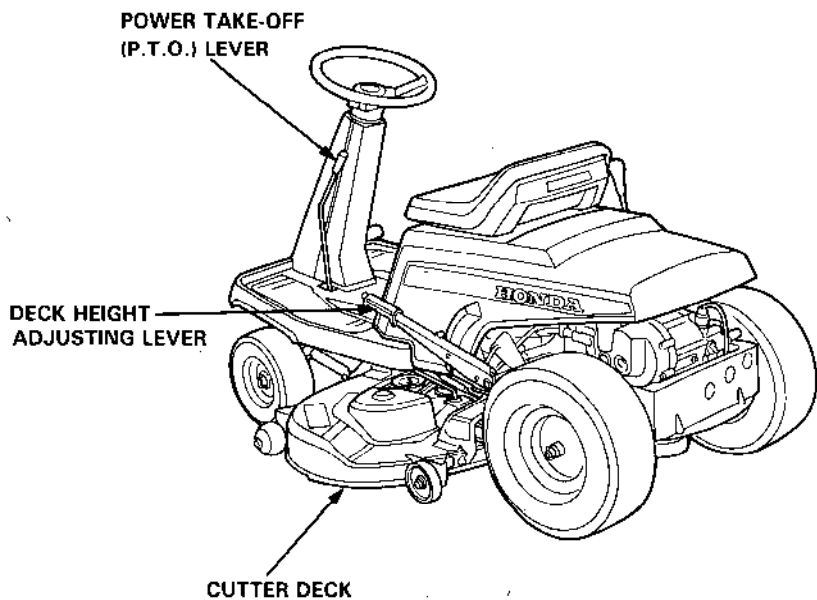

Engine compartment

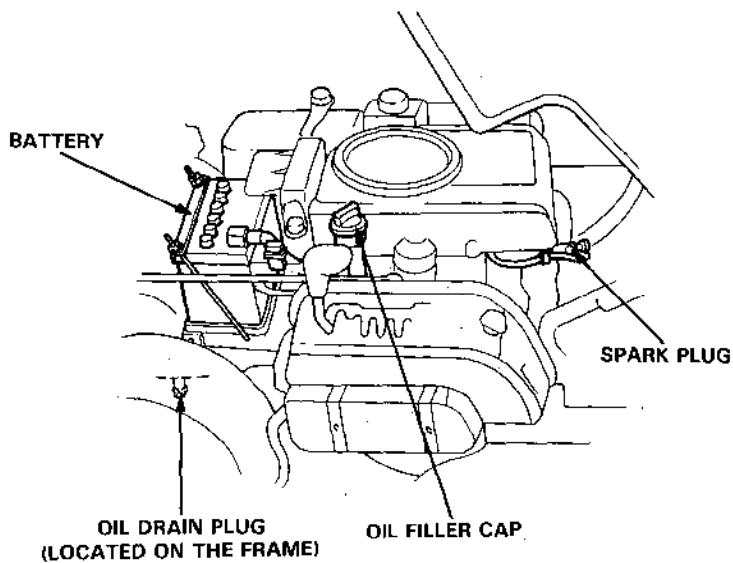
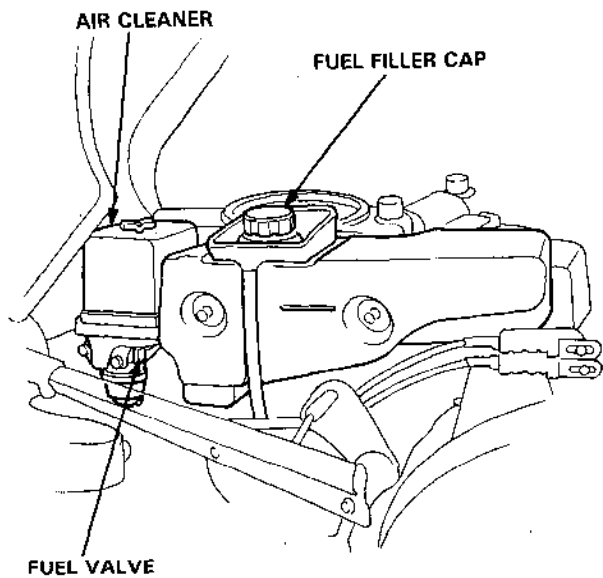

3. CONTROLS

1. Engine switch

WARNING Always remove the key from the engine switch whenever the riding mower is unattended to prevent children or unauthorized persons from starting the engine.

This riding mower is equipped with an automotive type ignition switch, which controls all the electrical circuits. The switch is located on the right-hand side in front of the gear shift lever.

Key positions: "START" to start the engine
"ON" to run the engine after starting
"OFF" to stop the engine.

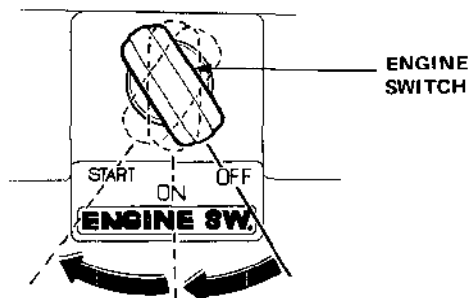

NOTE: The starter motor will not work unless the shift lever is in NEUTRAL and the P.T.O lever is in the OFF (Disengaged) position.

2. Throttle lever

The throttle lever controls engine speed from SLOW (idle) to FAST (max speed). START (CHOKE) is for starting a cold engine.

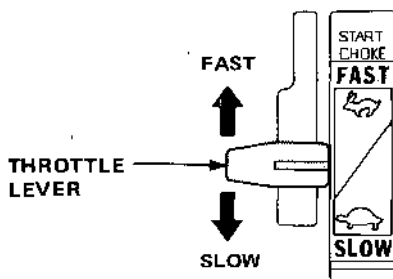

3. Cutter deck height adjusting lever

This lever is used to raise and lower the cutter deck. To adjust the cutting height, squeeze the handle lock and then press in and hold the set button. Raise or lower the lever until the desired cutting height appears on the indicator. At that point, release the set button and the handle lock. Be sure the handle lock returns to its normal position when released.

Cutting height: 1.0, 1.5, 2.0, 2.5, 3.0, 3.5 in. (Approx)

CAUTION:

- To avoid damage to the cutter deck, always raise it fully when driving the lawn tractor to and from the mowing area; this provides maximum ground clearance.
- To avoid damaging or disabling the handle locking mechanism, never attempt to screw the adjusting lever's set button in or out.

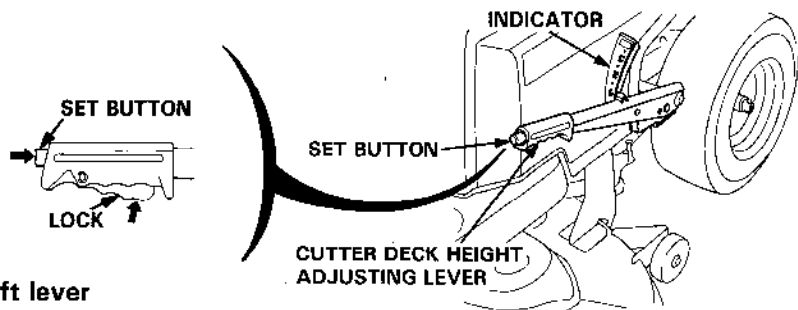

4. Shift lever

This lever is used to select one of the five forward speeds, neutral, or reverse. The drive clutch automatically disengages while the lever is being moved. The clutch will then engage automatically when put into gear unless the brake pedal is depressed.

WARNING Do not operate the shift lever on a slope.

CAUTION: Bring the riding mower to a complete stop before shifting from a forward speed to reverse, or from reverse to a forward speed. Shifting between forward and reverse speeds while the riding mower is moving can cause transmission damage.

When shifting from one forward speed range to another while moving, do not force the shift lever and do not shift up or down more than one slot at a time.

NOTE: The riding mower will pull away from a stop in any speed range. No shifting is necessary.

5th speed is not recommended for mowing but may be used for driving the riding mower from one area to another.

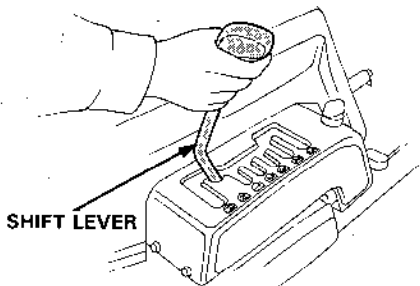

5. Power Take-Off (P.T.O.) lever

This lever engages and disengages the power take-off clutch to drive the blade.

Lever positions: ON (Engaged) Blade turns
OFF (Disengaged) Blade stops

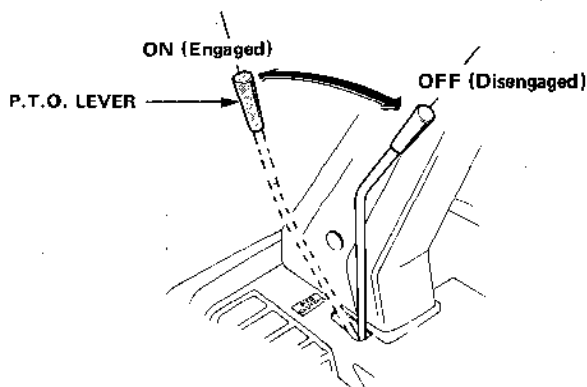

NOTE: An interlock switch prevents the engine from starting unless the P.T.O. lever is in the OFF position.

6. Brake pedal

Depressing the pedal will first disengage the riding mower drive clutch. As you continue to depress the pedal, the brake will be applied to stop the riding mower.

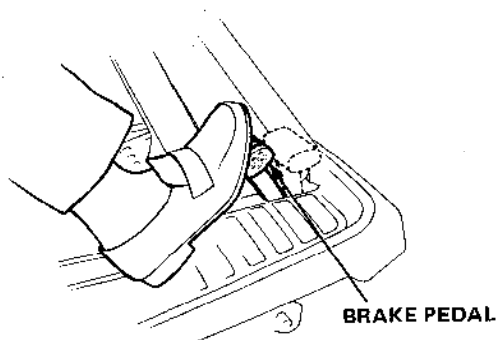

When the clutch pedal is released, the clutch will automatically engage smoothly.

CAUTION: Releasing the brake pedal too slowly can cause the clutch to *slip*, and may lead to premature clutch wear.

7. Warning buzzer

The warning buzzer has two functions which are described below.

A. Low oil level alarm (intermittent beeping sound)

If the oil level falls to a predetermined level while the engine is running, the warning buzzer will beep on and off. If this happens, stop the engine immediately, check the engine oil level and add enough of the recommended oil to bring the level to the upper mark on the dipstick (See page 16).

CAUTION: Running the engine with insufficient oil can cause serious engine damage.

B. Parking brake reminder (steady buzzing sound)

The warning buzzer will sound continuously if the transmission is shifted into gear while the parking brake is engaged. If you hear a steady buzz from the warning buzzer, release the parking brake or shift the transmission into neutral immediately (See page 14).

WARNING Operating the riding mower with the parking brake set will result in severe damage to the brake lining, and could lead to a complete brake system failure.

CAUTION: If the alarm changes from a steady buzz to an on and off beep when the parking brake is released, stop the engine immediately, and check the engine oil level.

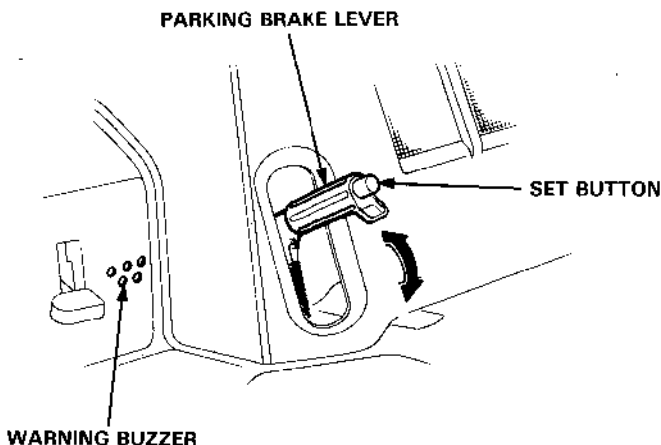

8. Parking brake lever

This lever is used to set the brake when the riding mower is parked. Pull the lever fully up until the ratchet locks.

NOTE: The parking brake lever does not operate the automatic clutch. Always put the transmission in neutral, or turn off the engine switch before setting the parking brake. A steady warning buzzer will sound if the parking brake is engaged while the transmission is in gear and the engine switch is ON.

CAUTION:

- When washing the riding mower, do not allow water to get into the warning buzzer holes.
- Never park the riding mower on a slope.

To release, pull the lever up slightly and press the lever set button, lower the lever while holding the button in.

WARNING Operating the riding mower with the parking brake set will result in severe damage to the brake lining, and could lead to a complete brake system failure.

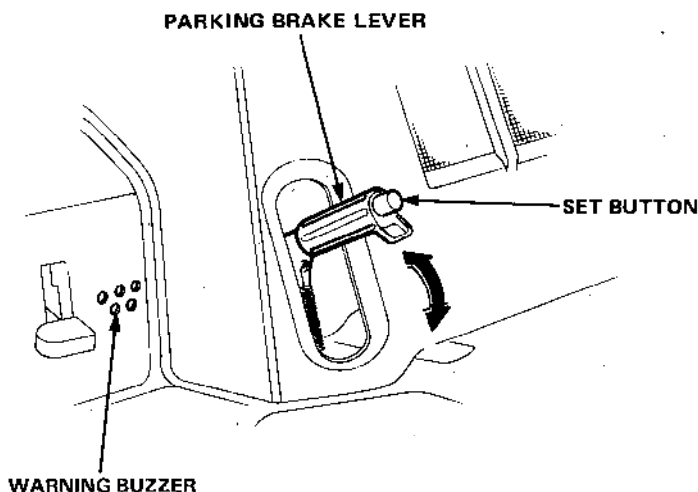

4. PRE-OPERATION CHECKS

WARNING To prevent accidental start-up, remove the engine switch key, and disconnect the spark plug cap before performing the pre-operation inspection.

1. Make sure the cooling air intake screens are clean.

CAUTION: If the cooling air intake screens are blocked the engine may overheat.

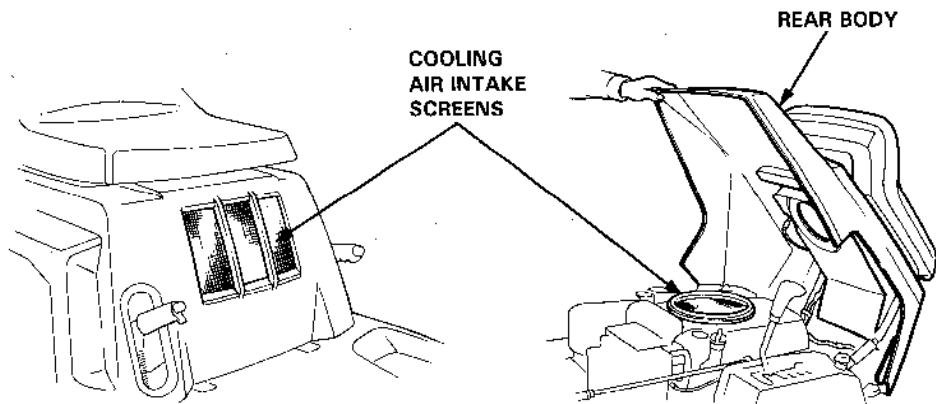

2. Check the engine oil level

CAUTION:

- Engine oil is a major factor affecting engine performance and service life. Non-detergent oil and 2-stroke engine oil are not recommended.
- Running the engine with insufficient oil can cause serious engine damage.

- Place the riding mower on a level surface.
- Lift the rear body, wipe dust and dirt from around the oil filler cap, remove the cap and wipe the dipstick clean.
- Insert the dipstick into the oil filler neck, but do not screw it in.
- Check the oil level shown on the dipstick. If near or below the lower level mark, fill to the upper level mark with the recommended oil.

Use Honda 4-stroke oil, or an equivalent high detergent, premium quality motor oil certified to meet or exceed U.S. automobile manufacturers' requirements for service classification SE or SF (Motor oils classified SE or SF will show this designation on the container).

SAE 10W-40 is recommended for general, all-temperature use.

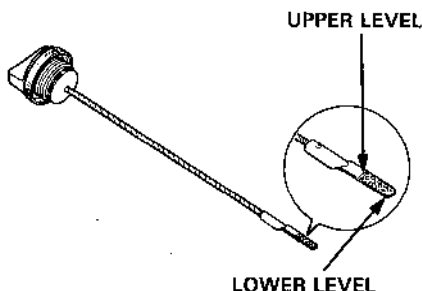
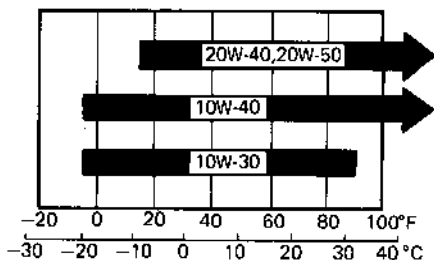
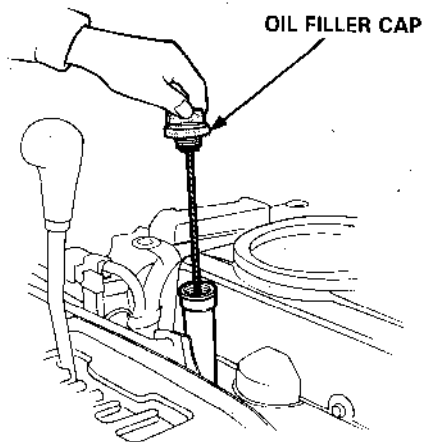

3. Check the fuel level

Raise the rear body and check the fuel level.

Refill the tank to the upper level mark if necessary.

Your engine is designed to use any gasoline that has a pump octane number $\left(\frac{R + M}{2}\right)$ of 86 or higher, or that has a research octane number of 91 or higher. Gasoline pumps at service station normally display the pump octane number.

We recommend that you use unleaded fuel because it produces fewer engine and spark plug deposits and extends the life of exhaust system components.

Never use stale or contaminated gasoline or an oil/gasoline mixture. Avoid getting dirt, dust or water in the fuel tank. Use of a lower octane gasoline can cause persistent "pinging" or heavy "spark knock" (a metallic rapping noise) which, if severe, can lead to engine damage.

CAUTION: If "spark knock" or "pinging" occurs at a steady engine speed under normal load, change brands of gasoline. If spark knock or pinging persists, consult your authorized Honda dealer. Failure to do so is considered misuse, and damage caused by misuse is not covered by Honda's Limited Warranty.

Occasionally you may experience light spark knock while operating under heavy loads. This is no cause for concern, it simply means your engine is operating efficiently.

After refueling, be sure to tighten the fuel tank cap firmly.

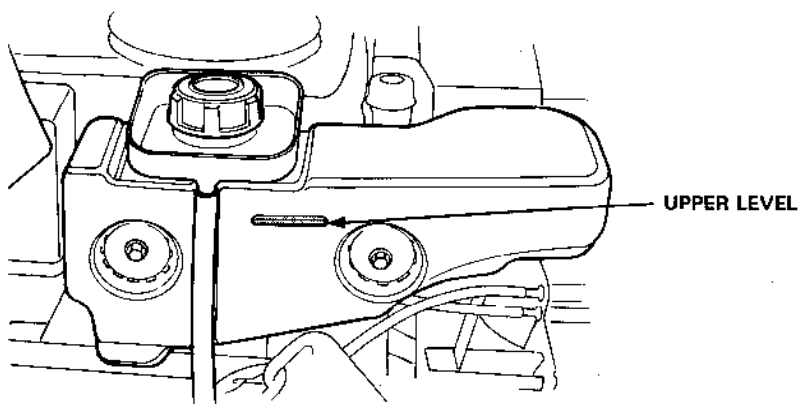

 **WARNING**

- Gasoline is extremely flammable and is explosive under certain conditions.
- Refuel in a well-ventilated area with the engine stopped. Do not smoke or allow flames or sparks in the area where the engine is refueled or where gasoline is stored.
- Do not overfill the fuel tank (there should be no fuel in the filler neck). After refueling, make sure the tank cap is closed properly and securely.
- Be careful not to spill fuel when refueling. Spilled fuel or fuel vapor may ignite. If any fuel is spilled, make sure the area is dry before starting the engine.
- Avoid repeated or prolonged contact with skin or breathing of vapor. **KEEP OUT OF REACH OF CHILDREN.**

GASOLINES CONTAINING ALCOHOL

If you decide to use a gasoline containing alcohol (gasohol), be sure it's octane rating is at least as high as that recommended by Honda. There are two types of "gasohol": one containing ethanol, and the other containing methanol. Do not use gasohol that contains more than 10% ethanol. Do not use gasoline containing methanol (methyl or wood alcohol) that does not also contain cosolvents and corrosion inhibitors for methanol. Never use gasoline containing more than 5% methanol, even if it has cosolvents and corrosion inhibitors.

NOTE:

- Fuel system damage or engine performance problems resulting from the use of fuels that contain alcohol is not covered under the warranty. Honda cannot endorse the use of fuels containing methanol since evidence of their suitability is as yet incomplete.
- Before buying fuel from an unfamiliar station, try to find out if the fuel contains alcohol, if it does, confirm the type and percentage of alcohol used. If you notice any undesirable operating symptoms while using a gasoline that contains alcohol, or one that you think contains alcohol, switch to a gasoline that you know does not contain alcohol.

4. Check the air cleaner elements

1. Raise the rear body.
2. Remove the two wing nuts to remove the air cleaner cover and air cleaner elements.

If the elements are dirty, follow the cleaning procedure described on page 39.

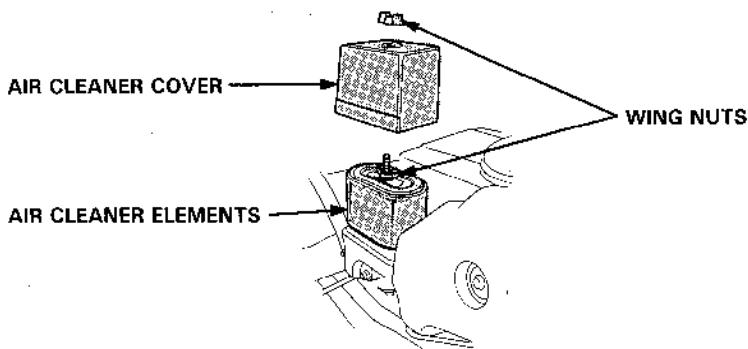

5. Check brake lining wear

Inspect brake lining condition every time the riding mower is used.

Firmly set the parking brake, and then check the position of the brake wear indicator. If the indicator is near the wear limit, take the riding mower to an Authorized Honda Power Equipment Dealer for repair.

CAUTION: Under no circumstances should the riding mower be operated if the brake lining is at the service limit.

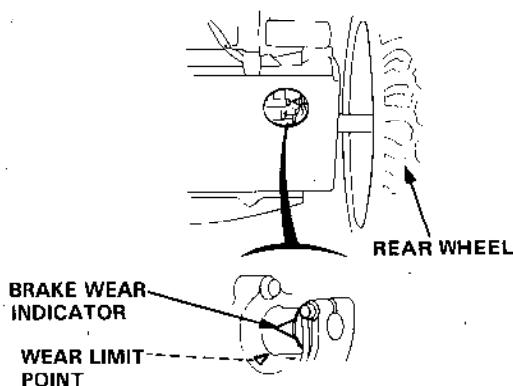
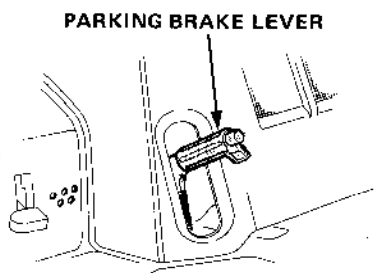

6. Deck belt, primary belt and blade belt inspection

■ Wear or damage

1. Lower the cutter deck as far as it will go with the cutter deck height adjusting lever.
2. Inspect both belts for wear and damage. If the belts are worn or damaged, replace them according to the instructions on pages 47—50.

■ Blade belt tension

1. Move the P.T.O. lever to the ON (Engaged) position.
2. Raise the cutter deck as far as it will go with the cutter deck height adjusting lever.
3. If the index mark on the tensioner arm aligns with or goes inward past the wear indicator on the cutter deck, adjust the belt tension according to the instructions on page 47.

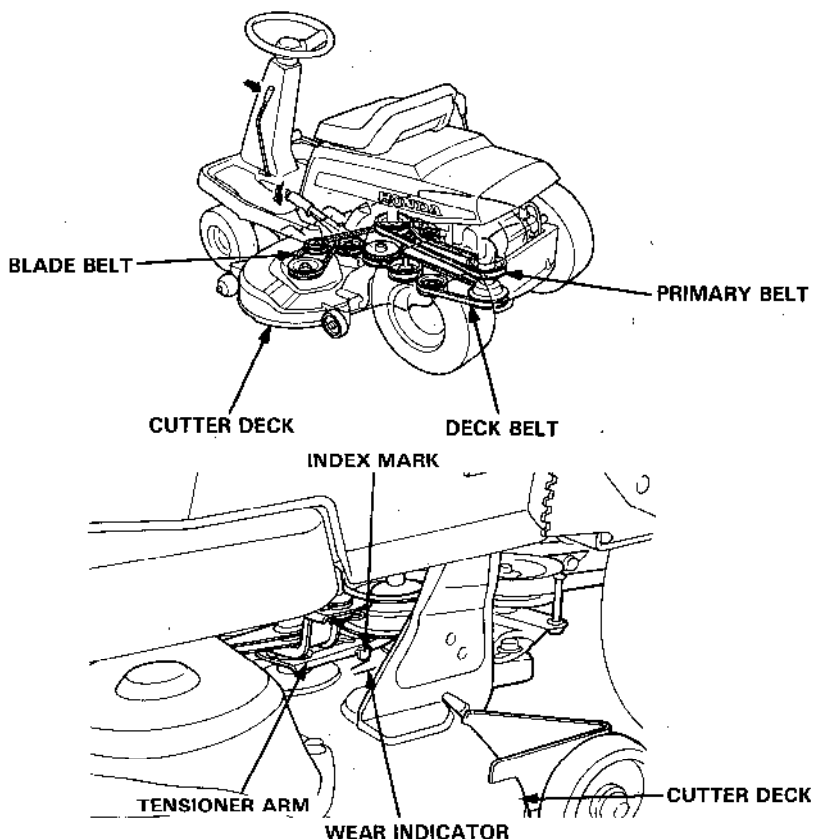

7. Check the battery

Raise the rear body, remove the battery cover and check the battery electrolyte level.

The electrolyte level must be maintained between the upper and lower level lines on the side of the battery.

If the electrolyte level is low, remove the battery filler caps and carefully add distilled water to the upper level line.

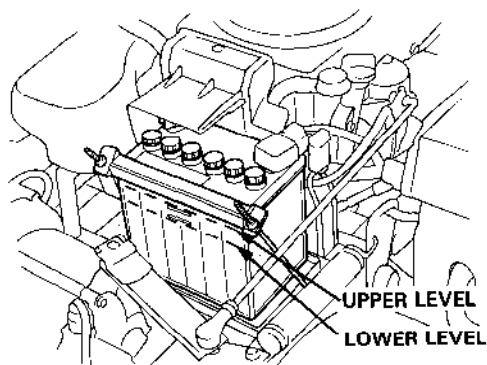

WARNING

- The battery gives off explosive gases; keep sparks, flames and cigarettes away. Provide adequate ventilation when charging or using batteries in an enclosed space.
- The battery contains sulfuric acid (electrolyte). Contact with skin or eyes may cause severe burns. Wear protective clothing and a face shield.
 - If electrolyte gets on your skin, flush with water.
 - If electrolyte gets in your eyes, flush with water for at least 15 minutes and call a physician immediately.
- Electrolyte is poisonous.
 - If swallowed, drink large quantities of water or milk and follow with milk of magnesia or vegetable oil and call a physician.
- KEEP OUT OF REACH OF CHILDREN.

CAUTION:

- Use only distilled water in the battery. Tap water will shorten the service life of the battery.
- Filling the battery above the UPPER LEVEL line may cause the electrolyte to overflow, resulting in corrosion to engine or nearby parts. Immediately wash off any spilled electrolyte.

8. Adjust the seat position

1. Raise the rear body.
2. Disconnect the 2-pin connectors.
3. Loosen the four seat mounting nuts.
4. Move the seat to a position that allows you to reach all controls easily and comfortably.
5. Tighten the seat mounting nuts securely. Be sure to re-connect the 2pin connectors.

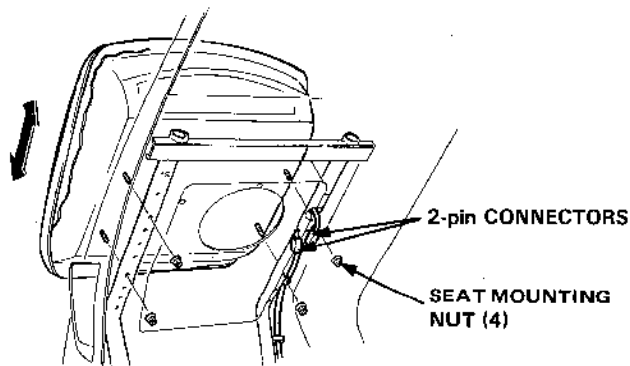

9. Check the tire pressure

CAUTION: Improper inflation may lead to premature tire failure. Never exceed the manufacturer's maximum tire pressure specification.

Check the tire pressure with an air pressure gauge.

Pressure: Front1.0 kg/cm² (14.2 psi)

Rear0.7 kg/cm² (9.96 psi)

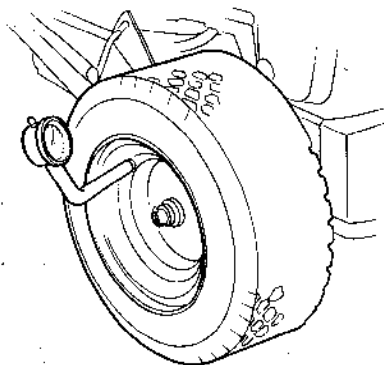

Starting the engine

WARNING Exhaust gas contains poisonous carbon monoxide. Never run the engine in an enclosed area. Be sure to provide adequate ventilation.

1. Raise the rear body, turn the fuel valve ON and close the rear body.

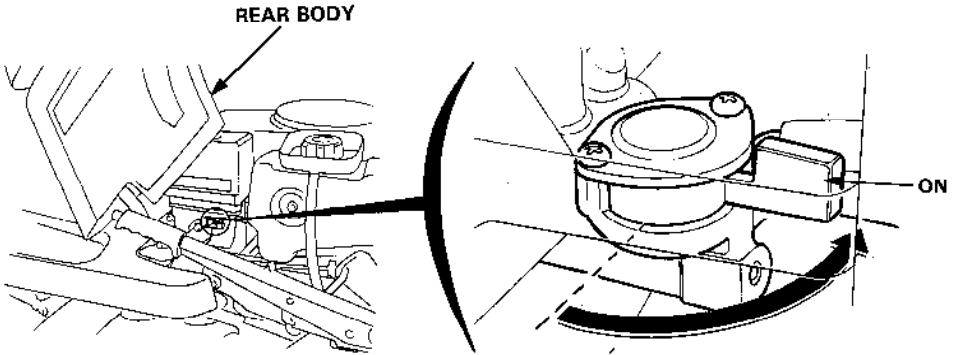

2. Sit on the seat and check that the parking brake lever is set, the transmission is in neutral and the P.T.O. lever is in the OFF (Disengaged) position.
3. Move the throttle lever to the START (CHOKE) position.

NOTE: When the engine is warm or the air temperature is high, move the throttle to SLOW.

START
(CHOKE)

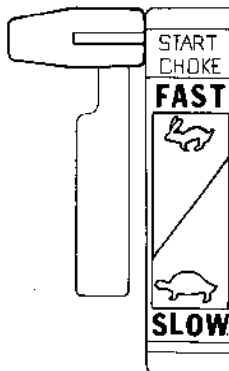

4. Turn the engine switch to START.

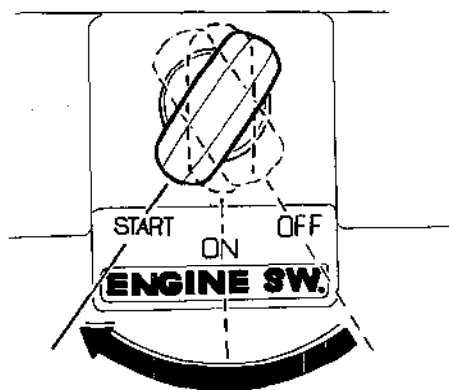

CAUTION: Do not use the starter motor for more than 5 seconds. If the engine fails to start, release the key, and wait at least 10 seconds before operating the starter motor again.

5. After the engine starts, let the engine switch return to ON.

6. After the engine warms up, move the throttle lever to the SLOW position.

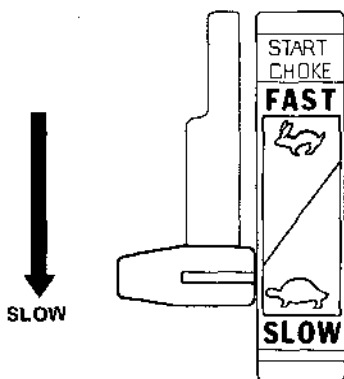

7. Seat safety switch operation check.

1. Move the P.T.O. lever to ON (Engaged).

Rise off the seat — the engine should stop immediately.

2. Return the P.T.O. lever to OFF (Disengaged) and restart the engine.

Release the parking brake and place the shift lever in the 1st speed range.

While driving slowly, rise off the seat — the engine should stop immediately.

CAUTION: Perform this check on level ground, never on a slope.

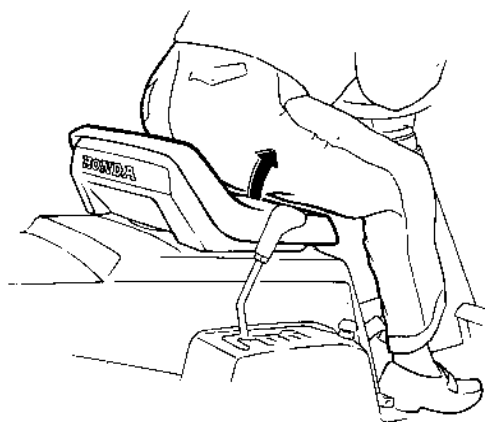

Mowing

WARNING Before operating this riding mower you should read and understand the safe operating rules. See page 4.

CAUTION: In tall grass, first mow with the cutter deck fully raised (3½ in); this will expose any hidden obstacles. When you are sure the area is completely cleared, re-mow at the desired height.

NOTE: For best results, wait until the lawn is dry before mowing.

1. Set the cutter deck height adjusting lever to the desired cutting height.

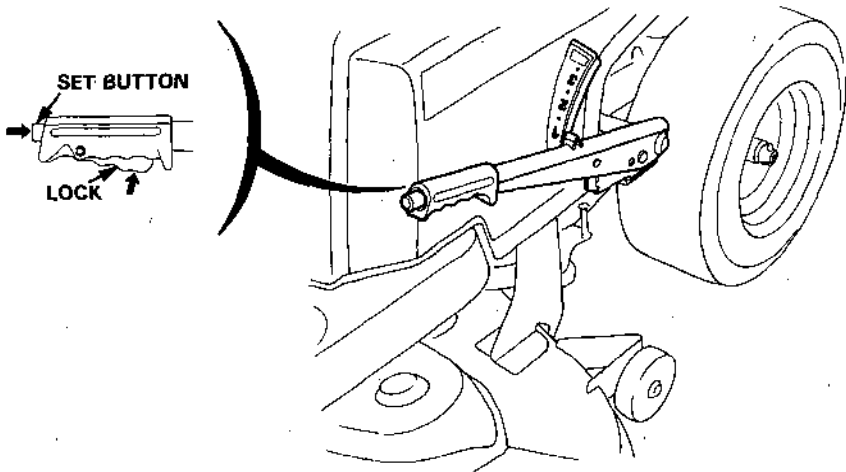

2. Move the throttle lever to the FAST position.

CAUTION: When mowing over rough ground or on hillsides, select the gear that will give a safe ground speed when the engine is operating at full throttle.

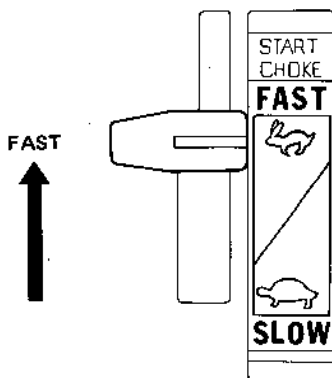

NOTE: The riding mower can be operated at intermediate throttle settings if desired, but always maintain sufficient engine speed for good pulling power and efficient blade operation. Use the shift lever to select the desired driving speed range.

3. Move the P.T.O. lever to the ON (Engaged) position.

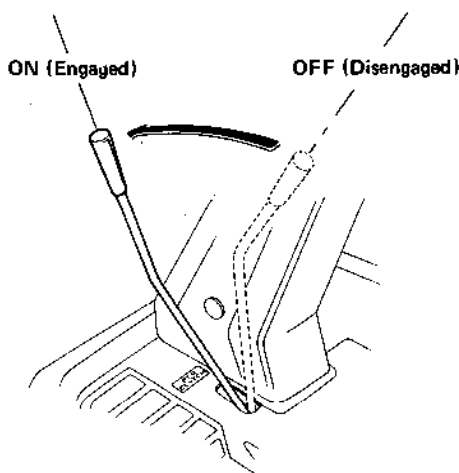

-
4. Move the shift lever to select the desired gear position. The clutch will engage automatically in about one second.

CAUTION: If clutch engagement occurs immediately or takes longer than one second, have the riding mower serviced by your HONDA dealer.

 **WARNING**

- Be sure the area behind the mower is clear of people, pets and other obstacles before backing up.
- Operate the mower at low speed until you become familiar with all of its operating characteristics.

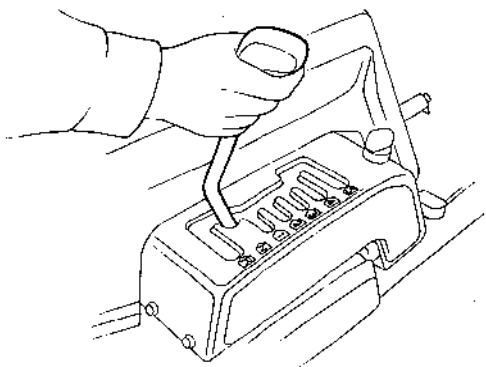

UPHILL STARTING PROCEDURE

 **WARNING**

If possible, avoid stopping the riding mower while driving uphill. However, if it is necessary to stop, follow this special procedure:

- A. Set parking brake.
- B. Apply pressure to the brake pedal.
- C. Move the throttle lever to mid range.
- D. Shift the transmission to 1st gear position.
- E. Release the brake pedal.
- F. Wait until the clutch engages.
- G. Then release the parking brake lever.

 **WARNING**

If the parking brake lever is released before the brake pedal, the riding mower may roll downhill before the clutch engages. This may cause the riding mower to tip over.

5. Cutting Patterns

WARNING These cutting patterns are only recommended for a flat, level lawn surface. See safe operating rules page 4.

- In a small area

First make 2 or 3 turns in a clockwise direction; then turn around and continue cutting in the reverse direction.

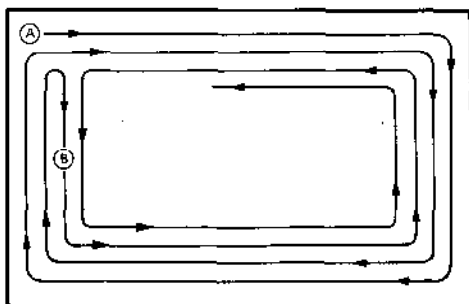

- In a large area

The first round of cuts is the key to making a neat finish. First, make 2 or 3 turns in a clockwise direction. As you reach the center of the area, turn to the right and continue cutting in a counterclockwise direction until you have finished the upper half of the area. Cut the grass in the remaining half in a counterclockwise direction.

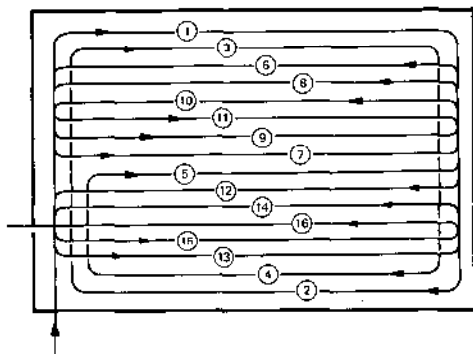

Stopping the engine

- In an emergency;
Turn the engine switch OFF.
- In normal use;
(1) Move the P.T.O. lever to
OFF (Disengaged).

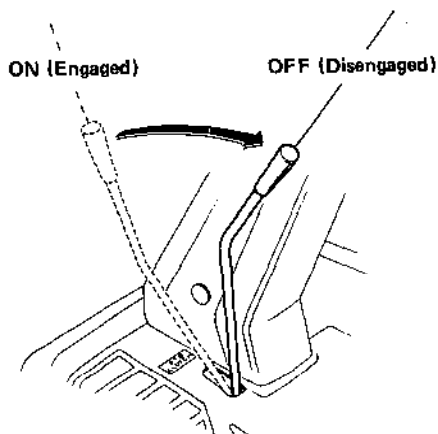

- (2) Move the shift lever to the Neutral position.
- (3) Set the parking brake.
- (4) Turn the engine switch OFF.
- (5) Raise the rear body, turn the fuel valve OFF and close the rear body.

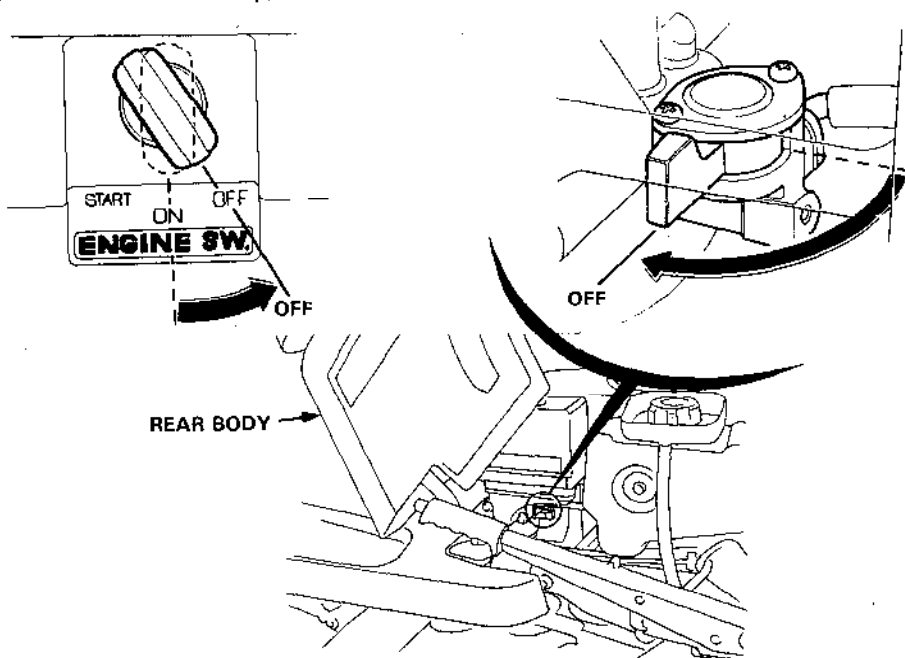

High altitude operation

At high altitude, the standard carburetor air-fuel mixture will be excessively rich. Performance will decrease, and fuel consumption will increase.

High altitude performance can be improved by installing a smaller diameter main fuel jet in the carburetor and readjusting the pilot screw. If you always operate the riding mower at altitudes higher than 6,000 feet above sea level, have your authorized Honda Riding Mower dealer perform these carburetor modifications.

Even with suitable carburetor jetting, engine horsepower will decrease approximately 3.5% for each 1,000 foot increase in altitude. The affect of altitude on horsepower will be greater than this if no carburetor modification is made.

CAUTION: Operation of the riding mower at an altitude lower than the carburetor is jetted for may result in reduced performance, overheating, and serious engine damage caused by an excessively lean air/fuel mixture.

6. TRANSPORTING/STORAGE

Transporting

Transport the riding mower on a flat, level trailer or pick-up truck, with suitable tie down points.

Turn the fuel valve OFF and set the parking brake lever.

Tie the riding mower down securely, using the tie down points shown below.

CAUTION: To avoid damaging the tie-rods, be careful not to put the rope around or near them when securing the front end.

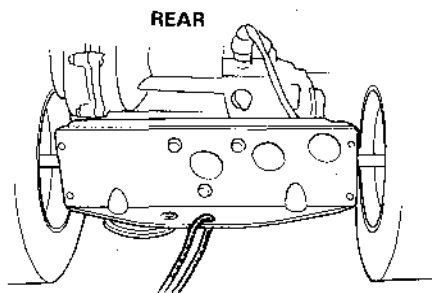
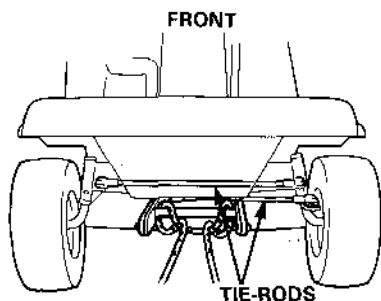

PROPER TIE-DOWN POINTS



WARNING Spilled fuel may ignite. To avoid fuel and oil spillage, keep the riding mower level when transporting.

CAUTION: Do not pull the riding mower behind any other vehicle, and do not use the riding mower to push another vehicle.

Preparation for storage

CAUTION: If the riding mower has been running, the engine will be very hot; allow to cool before proceeding.

The following steps should be taken to protect the riding mower whenever it will be stored for longer than 30 days.

1. Drain all gasoline from the fuel tank into an approved gasoline container.

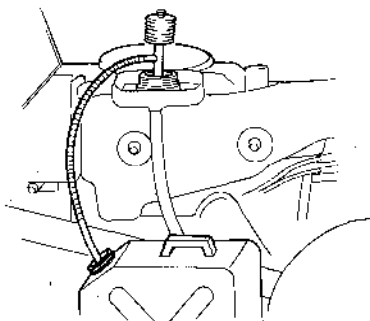

Turn the fuel valve ON, loosen the carburetor drain screw, and drain the fuel into an approved gasoline container. After draining tighten the drain screw securely.



WARNING Gasoline is extremely flammable and explosive under certain conditions. Do not smoke or allow flames or sparks in the area.

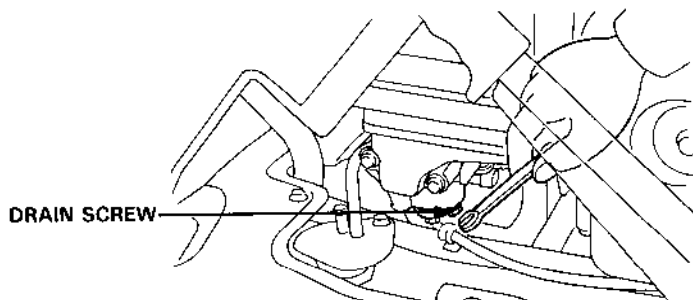

2. Change the engine oil (see page 40).

NOTE: If the riding mower will be stored for longer than 3 months, raise the rear body and remove the spark plug and pour three tablespoons (approximately 1 oz.) of clean motor oil into the cylinder.

Place the P.T.O. lever in the OFF position and the shift lever in the N position. With the parking brake applied, lower the cutter deck to the bottom. Reaching from the rear of the mower, grasp the primary belt at point A, and slowly pull it toward you to turn the engine. Reinstall the spark plug.

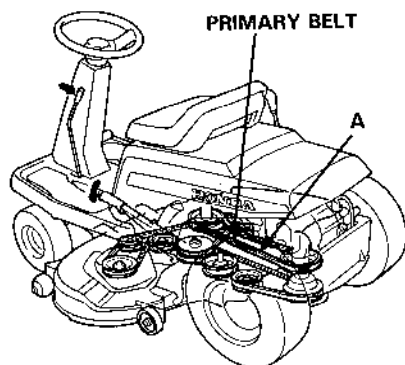
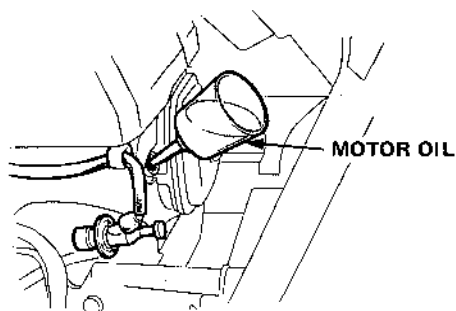

CAUTION: Be sure to wear heavy gloves when pulling the primary belt. If the riding mower has been running, the engine will be very hot. Allow it to cool before proceeding.

3. Remove the battery and store in a cool, dry place. Recharge it once a month.

4. Remove the cutter deck:

4-1. Lower the cutter deck and be sure the P.T.O. lever is in the OFF position. Turn the front wheels all the way to the left, and then remove the belt stopper.

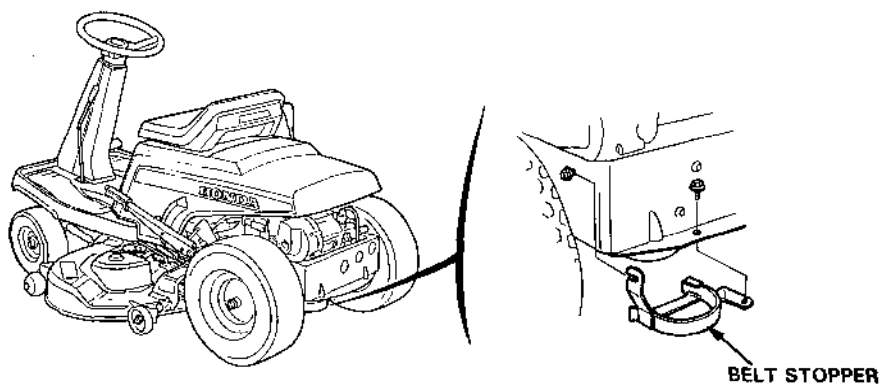

4-2. Remove the primary belt from the pulley on the underside of the transmission.

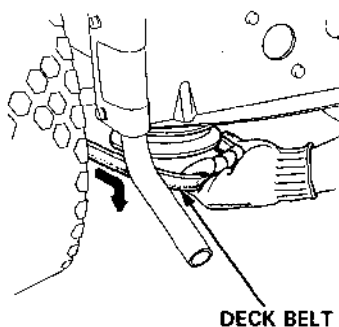

CAUTION: When the cutter deck is removed, the return spring will cause the deck height adjusting lever to snap upward when the release button is pressed. Hold the lever firmly, and carefully return it to the UPPER position after removing the deck.

- 4-3. Remove the 7 mm lock pin collar and washer from the P.T.O. clutch rod.
- 4-4. Remove the four 14 mm lock pins and washers from the right and left of the cutter deck.

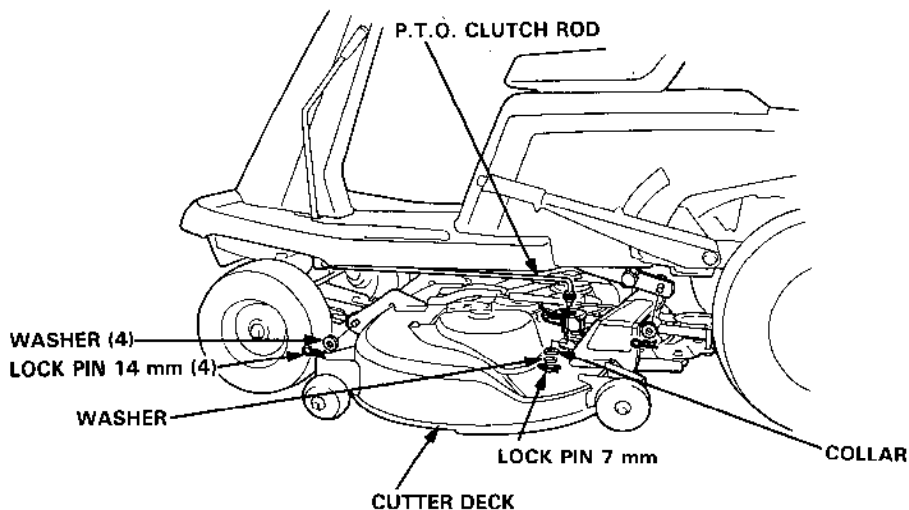

- 4-5. Remove the front deck arms from the frame body by removing the two lock pins and washers.

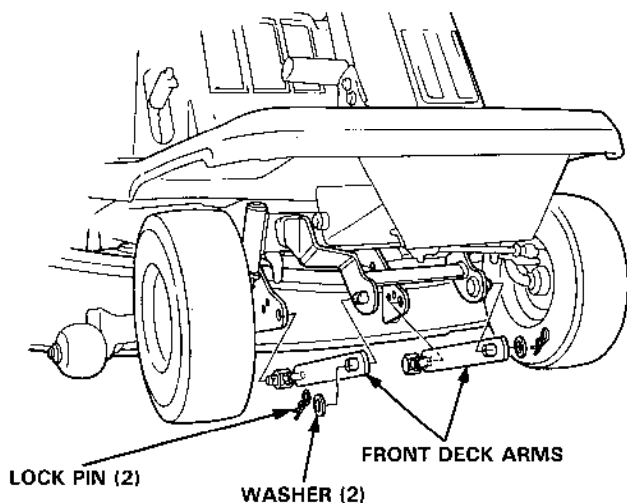

- 4-6. Disengage the cutter deck from the rear deck arms by moving it from side to side.

- 4-7. With the steering wheel all the way to the left, pull the cutter deck to the right and back.

CAUTION: Be careful to avoid hitting the muffler with the cutter deck during removal.

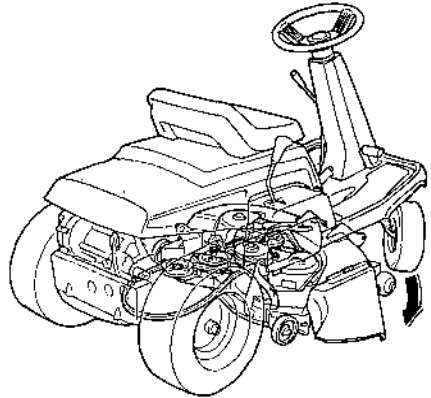

5. Turn the cutter deck upside down. Clean the underside of the deck with water, and dry thoroughly.
6. For longer service and greater efficiency, keep the underside of the mower housing clean and free of accumulated grass clippings by washing it down with a hose after use and/or cleaning it with a wire brush and scraper. Remove any rust and apply a rust-resistant paint. Cleaning and rust prevention are especially important before seasonal storage.
7. Reinstall the cutter deck by reversing the removal procedure.

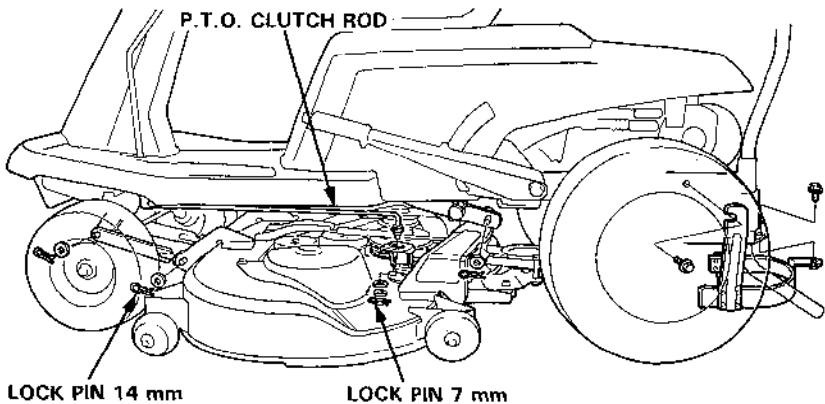

8. Store the riding mower on a level surface in a dry, dust-free area with the parking brake lever set.
9. Cover the riding mower to keep out dust.
10. Check tire air pressure regularly during storage and inflate if necessary.

Removal from storage

1. Check the battery electrolyte level (see page 21). Fully recharge the battery, and install it in the riding mower.
2. Remove the spark plug and check that it is clean and properly gapped (see page 42).
Turn the engine a few revolutions with the starter motor before reinstalling the spark plug.
3. Thread the spark plug in as far as possible by hand, then tighten it $1/8$ to $1/4$ turn further with the plug wrench.
4. Check the engine oil level (see page 16).
5. Fill the fuel tank, and start the engine by following the starting instructions (see page 23).

NOTE: If the cylinder was coated with oil, the engine will smoke at start up; this is normal.

7. MAINTENANCE

WARNING

- Shut off the engine and set the parking brake before performing any maintenance.
- To prevent accidental start-up, remove the engine switch key and disconnect the spark plug cap.
- The riding mower should be serviced by an authorized HONDA dealer unless the owner has proper tools and service data and feels he is mechanically qualified.

CAUTION: Use only genuine Honda parts or their equivalent for maintenance or repair. Replacement parts which are not of equivalent quality may damage the riding mower.

Periodic inspection and adjustment of the Honda HT-R3811 is essential if high level performance is to be maintained. Regular maintenance will also ensure a long service life. The required service intervals and the kind of maintenance to be performed are described on the following page.

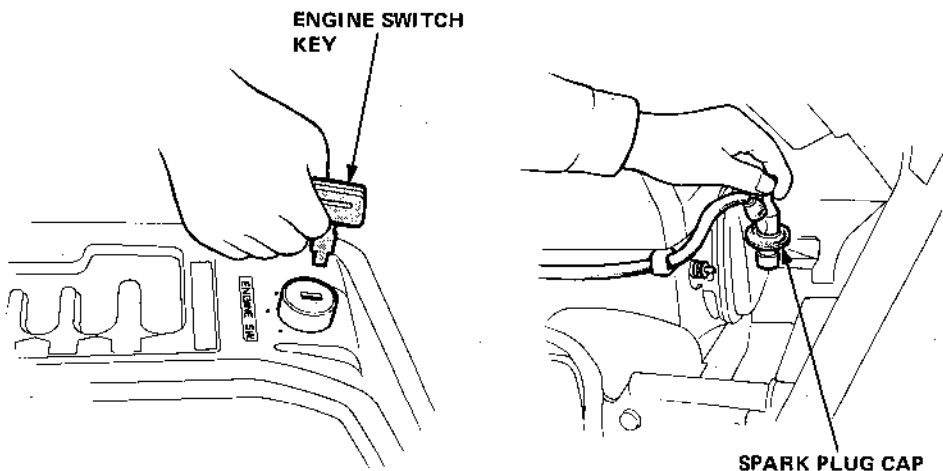

MAINTENANCE SCHEDULE

ITEM	REGULAR SERVICE PERIOD		EACH USE	FIRST 3 MONTHS OR 20 HRS (3)	EVERY 6 MONTHS OR 50 HRS (3)	EVERY YEAR OR 100 HRS (3)	EVERY 3 YEARS OR 300 HRS (3)
	Perform at every indicated month or operating hour interval, whichever comes first.						
Engine oil	Check level		○				
	Change			○		○	
Air cleaner	Check		○				
	Clean				○ (1)		
Seat switch operation	Check		○			○ (2)	
Cooling air intake	Clean		○				
Parking brake buzzer operation	Check		○		○ (2)		
Battery electrolyte	Check level		○				
	Check level and gravity				○ (2)		
Tire pressure	Check		○				
Deck belt	Check		○				
	Adjust			○	○		
Primary belt, blade belt	Check		○				
Grass bag (optional part)	Clean		○				
Foot brake	Check		○				
Blade bolt tightness and blade condition	Check			○ (2)	○ (2)		
Brake and clutch (fastener tightness)	Check			○ (2)		○ (2)	
Parking brake	Check				○ (2)		
Spark plug	Clean-Readjust					○	
Spark arrester (optional part)	Clean					○	
Drive clutch	Check-Adjust					○ (2)	
Fuel tank and filter	Clean					○ (2)	
Throttle cable	Check-Adjust					○ (2)	
Front axle	Grease					○ (2)	
Fuel line	Check (Replace if necessary)						○ (2)
Valve clearance	Check-Readjust						○ (2)
Engine fins and shroud	Clean						○ (2)

NOTE: (1) Service the air cleaner more frequently when used in dusty areas.

(2) These items should be serviced by an authorized Honda dealer, unless the owner has proper tools and is mechanically proficient.

(3) For professional commercial use, log hours of operation to determine proper maintenance intervals.

1. Engine oil change

NOTE: Drain the oil while the engine is still warm to assure rapid and complete draining.

1. Raise the rear body.
2. Remove the oil filler cap and the drain plug, and drain the oil into a suitable container.
3. Retighten the drain bolt securely.

NOTE: Before refilling the crankcase, check the operation of the Low Oil Level Alarm. Remove the spark plug cap, shift the transmission into neutral and turn the ignition key to the ON position. The warning buzzer should beep on and off; if it does not beep, take the riding mower to an authorized Honda riding mower dealer for repair.

4. Refill to the upper level mark on the dipstick with the recommended oil (see p. 15). Tighten the oil filler cap securely.

OIL CAPACITY: 1.1ℓ (1.2 US qt)

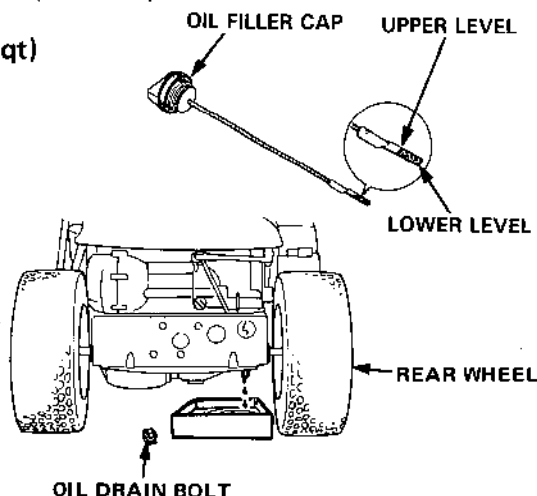
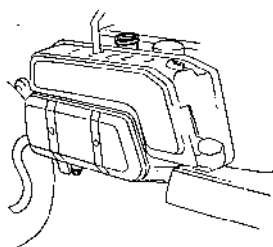

CAUTION: Used motor oil may cause skin cancer if repeatedly left in contact with the skin for prolonged periods. Although this is unlikely unless you handle used oil on a daily basis, it is still advisable to thoroughly wash your hands with soap and water as soon as possible after handling used oil.

NOTE: Please dispose of used motor oil in a manner that is compatible with the environment. We suggest you take it in a sealed container to your local service station for reclamation. Do not throw it in the trash or pour it on the ground.

2. Air cleaner service

A dirty air cleaner will restrict air flow to the carburetor. To prevent carburetor malfunction, service the air cleaner regularly. Service more frequently when operating the riding mower in extremely dusty areas.

WARNING Never use gasoline or low flash point solvents for cleaning the air cleaner element. A fire or explosion could result.

CAUTION: Never run the engine without the air cleaner. Rapid engine wear will result.

1. Raise the rear body.
2. Remove the wing nuts and the air cleaner cover. Remove the elements and separate them. Carefully check both elements for holes or tears and replace if damaged.
3. Foam element: Clean in warm soapy water, rinse and allow to dry thoroughly. Or clean in high flash-point solvent and allow to dry. Dip the element in clean engine oil and squeeze out all the excess. The engine will smoke during initial start-up if too much oil is left in the foam.
4. Paper element: Tap the element lightly several times on a hard surface to remove excess dirt, or blow compressed air through the filter from the inside out. Never try to brush the dirt off; brushing will force dirt into the fibers.

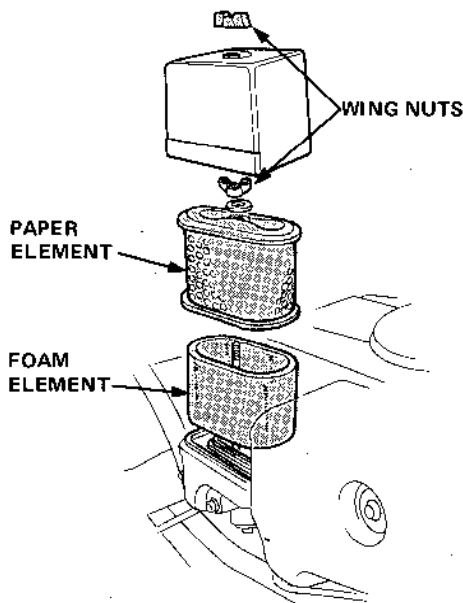

3. Spark plug service.

**Recommended spark plug: BPR5ES (NGK)
W16EPR-U (ND)**

To ensure proper engine operation, the spark plug must be properly gapped and free of deposits.

1. Raise the rear body and remove the spark plug cap.
2. Clean any dirt from around the spark plug base.
3. Use a spark plug wrench to remove the spark plug.

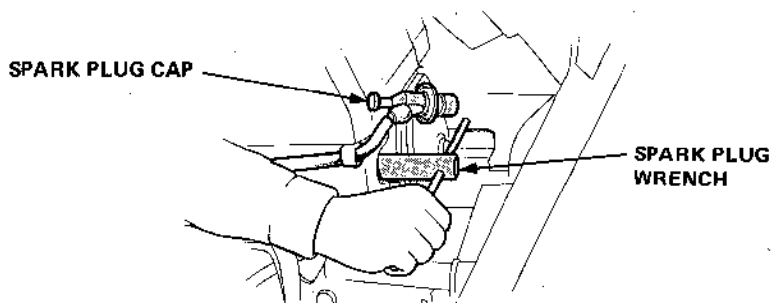

4. Visually inspect the spark plug. Discard it if the insulator is cracked or chipped. Clean the spark plug with a wire brush if it is to be reused.
5. Measure the plug gap with a feeler gauge.
The gap should be 0.7 – 0.8 mm (0.028 – 0.031 in). Correct as necessary by carefully bending the side electrode.

0.7 – 0.8 mm
(0.028 – 0.031 in)

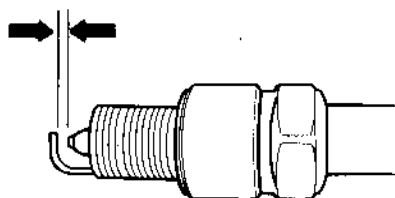

6. Thread the plug in by hand to prevent cross threading.

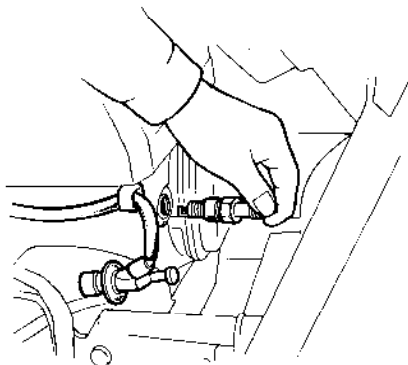

7. After a new spark plug has been seated by hand, it should be tightened 1/2 turn with a wrench to compress its washer.

If a used plug is being reinstalled, it should only require 1/8 to 1/4 turn after being seated.

CAUTION:

- The spark plug must be securely tightened. An improperly tightened plug can become very hot and possibly damage the engine.
- Never use a spark plug with an improper heat range.

4. Battery electrolyte level check

Raise the rear body, remove the battery cover and check the electrolyte level in each battery cell. Fill the battery with distilled water to the upper level line. Never overfill the battery.

Any corrosion around the positive and negative terminals should be washed off with a solution of baking soda and warm water. Dry the terminals and retighten the terminal bolts if necessary, then coat the terminals with grease.

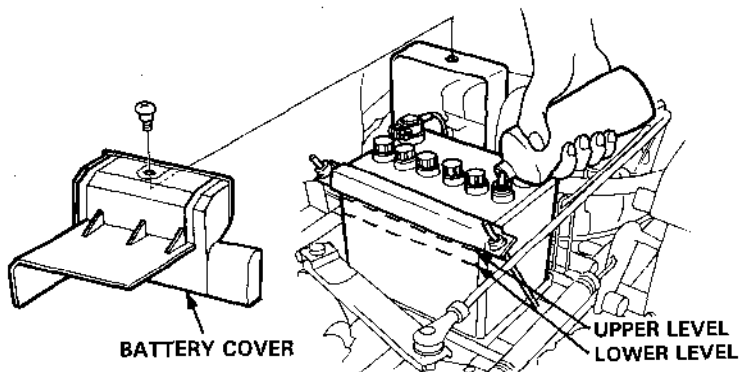

WARNING

- The battery gives off explosive gases; keep sparks, flames and cigarettes away. Provide adequate ventilation when charging or using batteries in an enclosed space.
- The battery contains sulfuric acid (electrolyte). Contact with skin or eyes may cause severe burns. Wear protective clothing and a face shield.
 - If electrolyte gets on your skin, flush with water.
 - If electrolyte gets in your eyes, flush with water for at least 15 minutes and call a physician immediately.
- Electrolyte is poisonous.
 - If swallowed, drink large quantities of water or milk and follow with milk of magnesia or vegetable oil and call a physician.
- KEEP OUT OF REACH OF CHILDREN.

CAUTION:

- Use only distilled water in the battery. Tap water will shorten the service life of the battery.
- Filling the battery above the UPPER LEVEL line may cause the electrolyte to overflow, resulting in corrosion to engine or nearby parts. Immediately wash off any spilled electrolyte.

5. Drive clutch inspection

1. Place the shift lever in the "2" position.
2. Using light pressure, push the clutch arm toward the front of the riding mower until you feel resistance. At this point the index mark on the clutch arm should be between the two notches on the clutch cable joint. If the index mark moves to the service limit notch, the clutch disk may be worn out; consult your authorized Honda dealer.

NOTE: Do not force the clutch arm during this inspection, or a false failure indication will result.

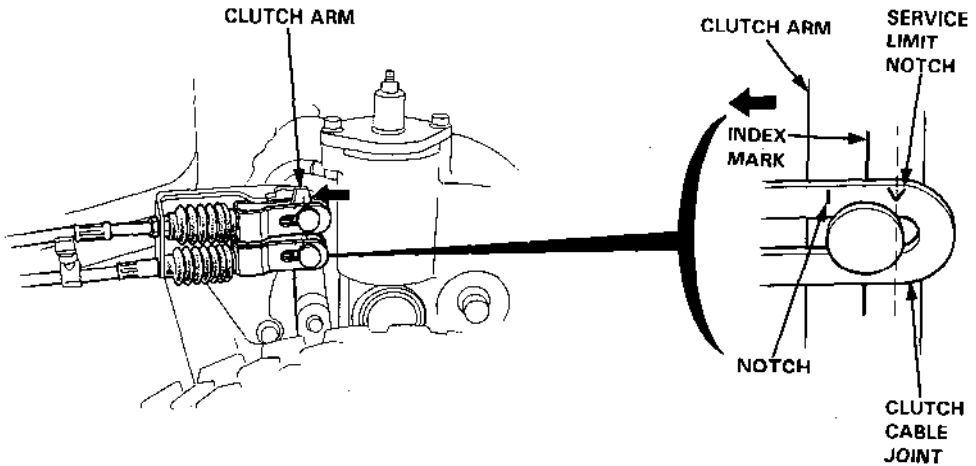

6. Wheel removal

WARNING

- Do not attempt to remove a wheel unless the riding mower is on firm and level ground.
- Do not attempt to remove or replace a tire unless you have the equipment and knowledge to do so properly.

Block the wheels securely.

Front wheel

1. Remove the cotter pin.
2. Jack up the front of the mower and remove the 12 mm wheel hub nut, washer and the front wheel.
3. Install the front wheel in the reverse order of removal. Be sure to use a new cotter pin and bend it properly as shown.

Rear wheel

1. Remove the cotter pin.
2. Jack up the rear of the mower and remove the 14 mm wheel hub, washer nut and the rear wheel.
3. Apply a thin coat of grease to the axle (splined portion) before installing the rear wheel.
4. Install the rear wheel in the reverse order of removal. Be sure to use a new cotter pin and bend it properly as shown.

[JACK POINTS]

FRONT

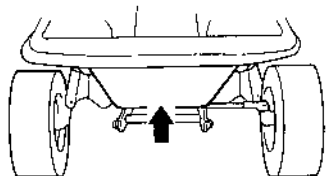

REAR

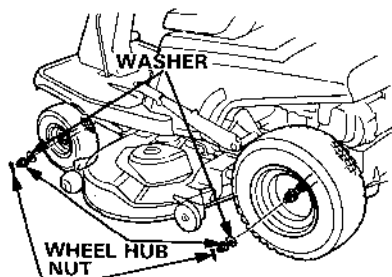
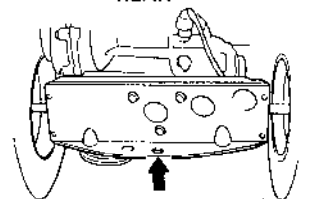

COTTER PIN

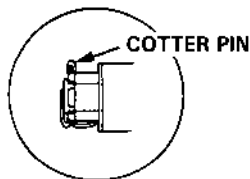

COTTER PIN

7. Deck belt adjustment/replacement



WARNING Never attempt to change a belt while the engine is running. Remove the engine key from the ignition and disconnect the spark plug cap to prevent accidental start up.

CAUTION: Wear heavy gloves to protect your hands when replacing belts or when working with the cutter blade.

■ Adjustment

1. Set the steering wheel in the straight-ahead position.
2. Move the P.T.O. lever to the ON (Engaged) position.
3. Lower the cutter deck as far as it will go with the cutter deck height adjusting lever.
4. Loosen the 8 x 16 mm flange bolt, and pull the tensioner pulley outward until the index mark on the tensioner arm aligns with the tension alignment mark on the cutter deck. Hold the tensioner pulley in place, and retighten the bolt.

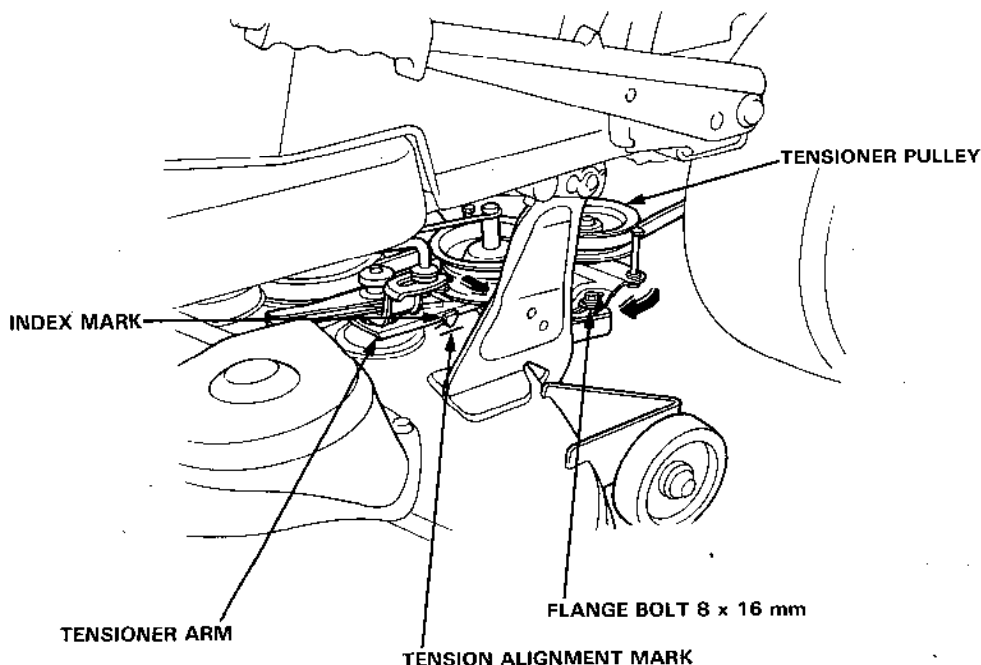

■ Replacement

1. Remove the cutter deck (see pages 34 thru. 36).
2. Remove the blade belt (see page 49).
3. Hold the bracket and move the knob to the right so that the tensioner arm moves in the direction indicated by the arrow.

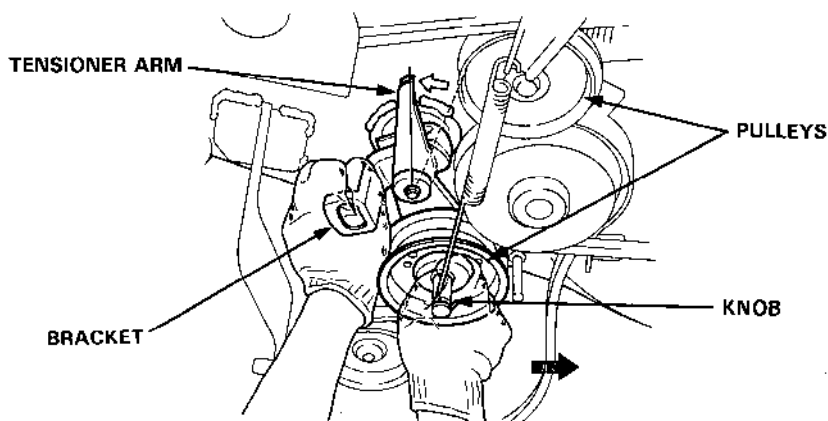

CAUTION:

- Wear heavy gloves to protect your hands when replacing the blade belt, and don't put your hands between the pulleys.
- Grasp the knob on the tensioner pulley firmly, and return the tensioner arm slowly; don't let it snap back.

4. Remove the belt guide plate by removing the two 8 mm bolts.
5. Remove the two belt guide bolts and remove the deck belt.
6. The installation sequence is essentially the reverse order of removal.

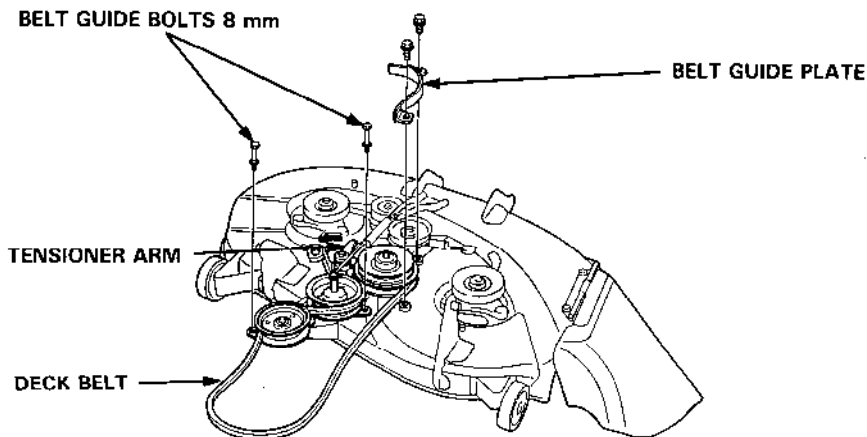

8. Blade belt replacement

1. Remove the cutter deck (see pages 34 thru. 36).
2. Remove the pulley covers by removing the one 8 mm bolt and three 8 mm nuts.
3. Pull the A portion of the blade belt toward the direction indicated by the arrow and remove the blade belt from the pulley A.
4. Install a new blade belt in the reverse order of removal.
5. Rotate the pulley to check that the belt moves smoothly after assembly.

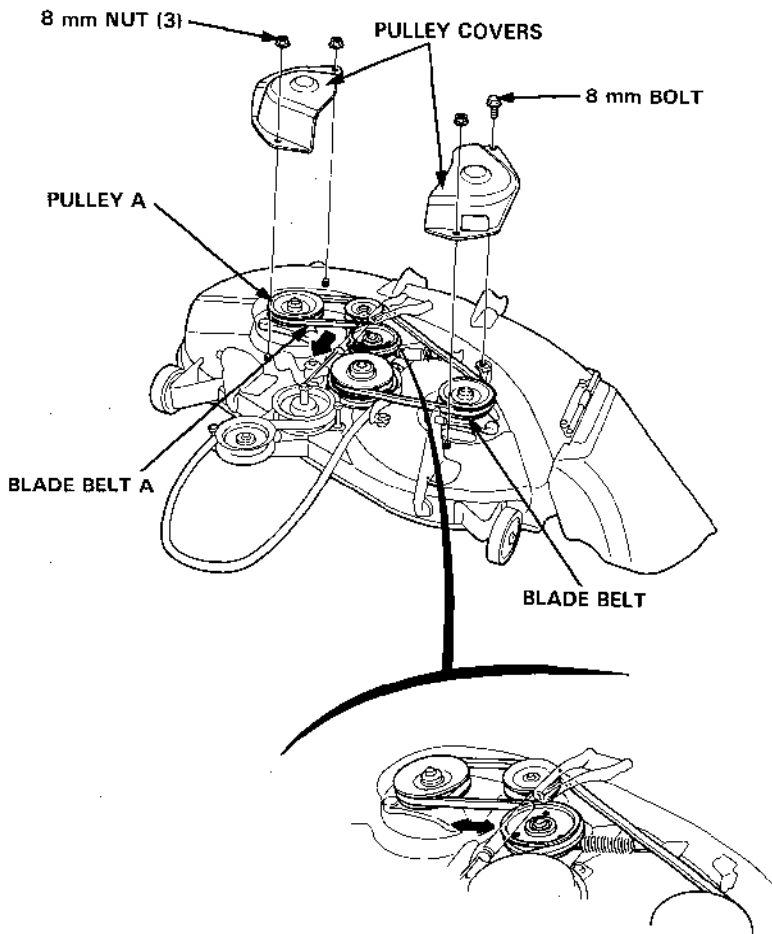

9. Primary belt replacement

CAUTION: Wear heavy gloves to protect your hands when replacing the belt.

1. Remove the cutter deck (see page 34 thru. 36).
2. Remove the primary belt from the pulley on the belt tensioner arm while pressing out on the arm by hand. Then, remove the primary belt from the pulley on the engine.
3. Remove the tensioner arm by removing the 10 mm bolt and remove the primary belt by pulling it out by hand.
4. Install a new primary belt. Install the remaining parts in the reverse order of removal.

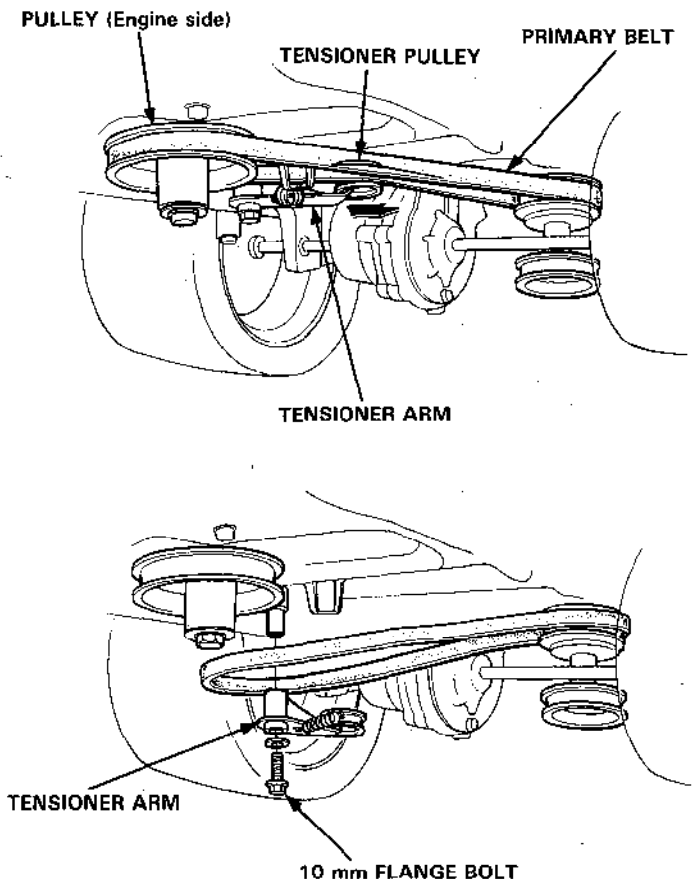

10. Blade inspection, sharpening and replacement

WARNING Never attempt to change a blade while the engine is running. Remove the ignition key from the ignition and disconnect the spark plug cap to prevent accidental start up.

CAUTION: Always wear heavy gloves to protect your hands when working with the cutter blade.

■ Blade inspection

1. Remove the cutter deck from the riding mower (see page 34 thru. 36).
2. Inspect the blade for cracks, bends or signs of wear. If the blade is bent, damaged or badly worn, replace it.

CAUTION: Use only genuine Honda replacement blade or their equivalent.

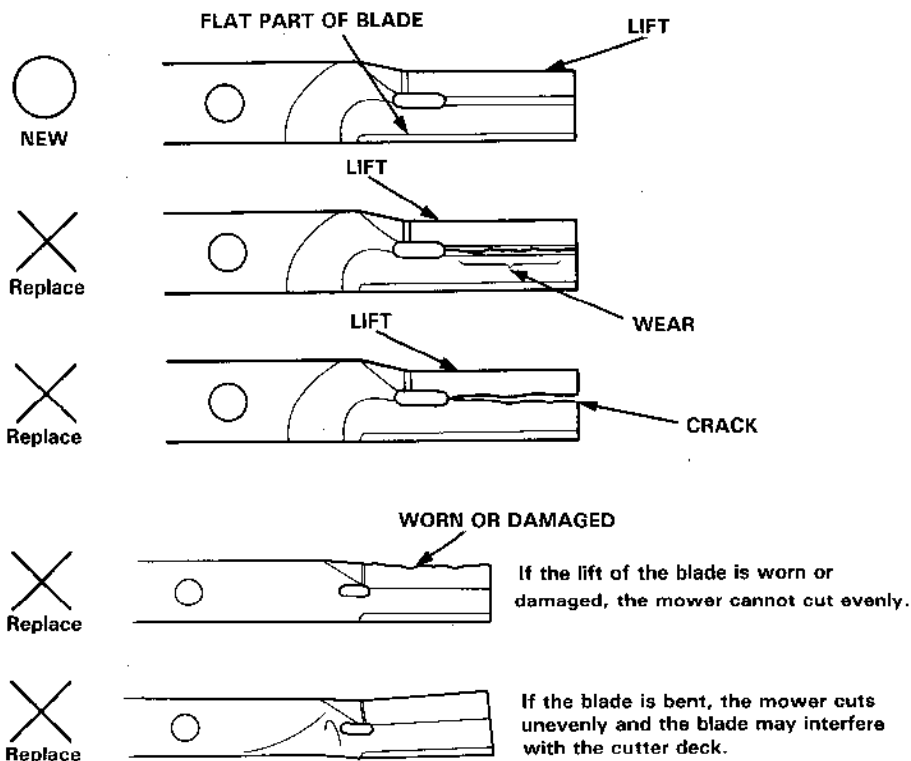

■ Blade sharpening

CAUTION: Always wear heavy gloves to protect your hands when working with the cutter blade.

1. Remove the cutter deck (see page 34 thru. 36), and turn it upside down.
2. Remove the blade bolts and the blade.

CAUTION: To avoid damaging the blade, be sure to hold it securely while dressing or resharpening it.

3. Maintain the original cutting edge bevel when resharpening or dressing the blade. Leave a $1/64$ inch (0.4mm) flat face on the cutting edge; a razor-sharp edge will chip easily, and will become dull quickly.

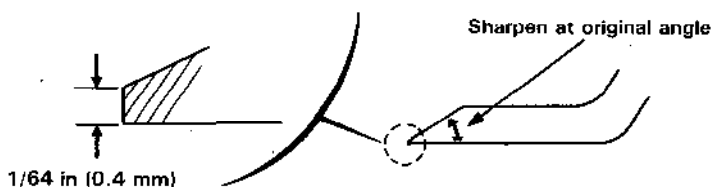

4. When resharpening, do not file the blade parallel to the original edge. Instead, file the blade on an angle as shown, and do not extend the cutting edge any farther toward the center of the blade. Be sure to remove equal amounts of material from each end of the blade to maintain proper balance.

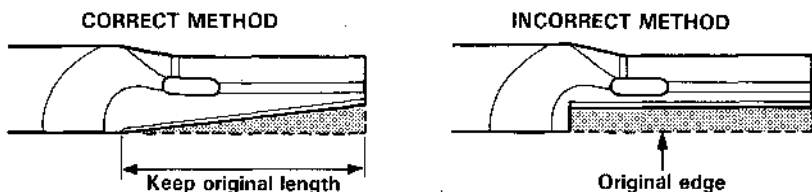

5. After sharpening, test the blade's balance using a screwdriver as shown. If either side dips slightly below horizontal, file that side. Replace the blade if it dips excessively.

CAUTION: An unbalanced blade will cause abnormal vibration, and eventual mower damage.

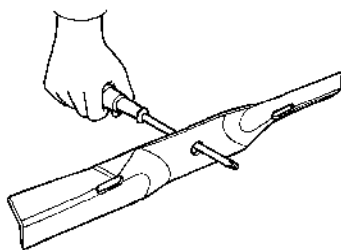

■ Blade replacement

CAUTION: Always wear heavy gloves to protect your hands when working with the cutter blade.

1. Hold the blade firmly, and remove the blade bolt, washer and blade.

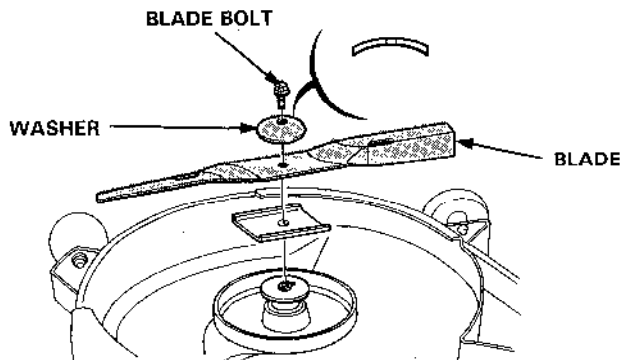

2. Clean any dirt and grass from around the blade shaft and inside the deck.
3. Install a new blade onto the shaft and secure it with the blade bolt and washer. Tighten the bolts securely and install the mower deck.

Blade bolt tightening torque: 4.5–5.5 kg-m (32.55–39.78 ft-lb)

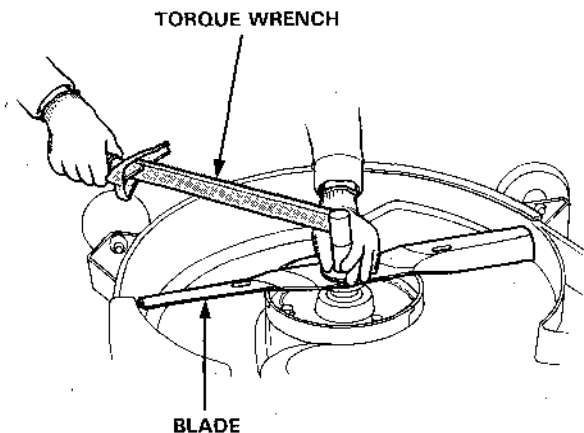

11. Spark arrester maintenance (optional part)

You can purchase an optional, U.S.D.A. qualified spark arrester from your authorized Honda Power Equipment dealer. Spark arrester are required in some areas; check local laws and regulations before operating your riding mower.

WARNING The muffler becomes very hot during operation and remains hot for a while after the engine stops. Be careful not to touch the muffler while it is hot. Allow it to cool before proceeding.

CAUTION: The spark arrester must be serviced every 100 hours to maintain its efficiency.

1. Remove the three 6 mm bolts and 8 mm bolt that hold the shift lever guide stay, and then remove the stay.
2. Remove the two 6 mm bolts from the exhaust pipe tip. Remove the exhaust pipe tip and spark arrester (be careful not to damage the spark arrester screen).
3. Use a wire brush to remove carbon deposits from the spark arrester screen.

NOTE: Inspect the spark arrester, and replace it if the screen is broken or torn.

4. Reinstall all parts in the reverse order of removal.

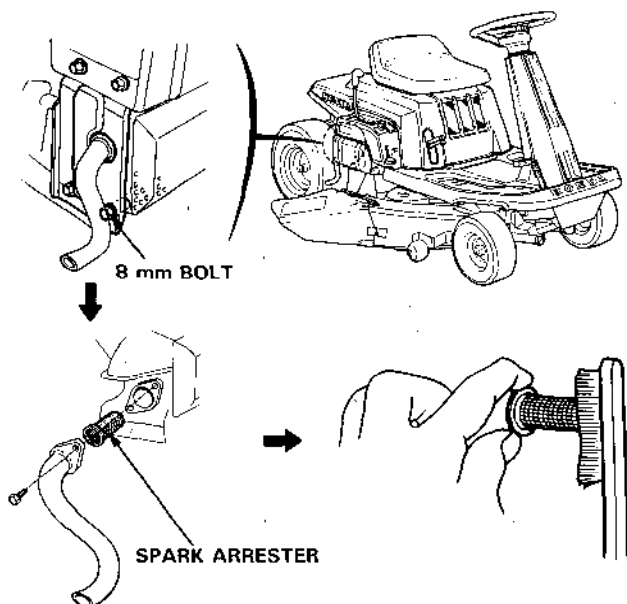

8. TROUBLESHOOTING

Engine fails to start;

1. No fuel. —————> Add fuel.
2. Shift lever in gear. —————> Position shift lever in NEUTRAL.
3. P.T.O. lever engaged. —————> Position blade (P.T.O.) lever in DISENGAGE.
4. Spark plug faulty or improperly gapped. —————> Regap plug or replace (see p. 42).
5. Spark plug wire loose or disconnected. —————> Check spark plug wire.
6. Fuel not reaching carburetor. —————> Check the position of the fuel valve (see p. 23). If that's not the problem, see your authorized HONDA dealer.
7. Discharged battery or loose terminal. —————> Charge battery or retighten terminal. (see p. 44).

Engine loses power;

1. Dirty air cleaner elements. —————> Clean or replace elements (see p. 41).
2. Spark plug faulty or improperly gapped. —————> Regap plug or replace. (see p. 42).
3. Engine overloaded. —————> Shift to lower speed.

Engine overheats;

1. Cooling air intake plugged. —————> Clean cooling air intake (see p. 15).
2. Engine overloaded. —————> Shift to lower speed.
3. Spark plug improperly gapped. —————> Regap plug or replace (see p. 42).
4. Cooling fan damage —————> See your authorized HONDA dealer.

Erratic operation;

1. Dirty fuel. —————> See your HONDA dealer.
2. Dirty air cleaner elements. —————> Clean air cleaner elements (see p. 41).
3. Spark plug faulty or —————> Regap plug or replace (see p. 42).
improperly gapped.

Excessive vibration;

1. Loose blade or engine —————> Retighten blade bolts or engine
mounting hardware. mounting hardware to the specified
torque.
2. Blade damaged or out of —————> Replace blades.
balance.

Battery will not charge;

1. Dead cell in battery. —————> Replace battery.
2. Loose electrical connec- —————> Check connections and lines.
tions or broken wire.

Uneven mowing;

1. Riding mower speed too fast —————> Shift to lower speed.
2. Grass accumulation —————> Clean deck inside (see p. 36).
inside deck.
3. Dull blade. —————> Sharpen blade or replace.
4. Tires improperly inflated. —————> Check tire inflation (see p. 22).
5. Mower not level. —————> Check cutter deck mounting.
See your authorized HONDA dealer.
6. Wrong cutter deck height. —————> Change to proper height.
7. Chute clogged (if equipped —————> Empty grass bag and chute.
with optional grass bag).

Clogged cutter deck discharge chute.

1. Wrong blades —————> Use genuine Honda blades or equivalent.
2. Deck too low. —————> Raise deck and adjust deck height properly.
3. Engine overloaded. —————> Operate at full throttle. Use lower speed range. Set cutter deck higher than desired height for first pass, then cut to desired height on second pass.
4. Grass bags full —————> Empty grass bags.
(Optional part).

Blades do not rotate or stop.

1. Blade belt worn or broken. —————> Replace with new belt (see p. 47–50).
2. P.T.O. lever malfunction —————> See your authorized HONDA dealer.

Riding mower does not move, or clutch does not engage properly when the transmission is shifted into gear.

1. Faulty clutch assy. —————> See your authorized HONDA dealer.
2. Transmission does not —————> See your authorized HONDA dealer.
shift gear.
3. Abnormal clutch engage- —————> See your authorized HONDA dealer.
ment.

9. SPECIFICATIONS

MODEL	HT-R3811
Power products description code	MABT
ENGINE	
Model	GXV340
Type	4-stroke, overhead valve, 1 cylinder
Displacement	337 cm ³ (20.6 cu in)
Bore and stroke	82 x 64 mm (3.2 x 2.5 in)
Ignition timing	20° BTDC
Ignition system	Transistorized magneto
Cooling system	Forced air
Engine oil capacity	1.1 ℓ (1.2 US qt)
Spark plug	BPR5ES (NGK), W16EPR-U (ND)
FRAME	
Dimensions	
Length x Width x Height	1535 x 1260 x 1000 mm (60.4 x 49.6 x 39.4 in)
Wheel tread	
Front	570 mm (22.4 in)
Rear	635 mm (25.0 in)
Wheel base	1100 mm (43.3 in)
Cutting width	970 mm (38.0 in)
Cutting height	1, 1½, 2, 2½, 3, 3½ in. (Approx)
Dry weight	177 kg (390.2 lb)
Tire size	Front 11 x 4.00 – 5 Rear 16 x 6.50 – 8
Air pressure	Front 1.0 kg/cm ² , Rear 0.7 kg/cm ²
Gear selections	5 Forward, 1 Reverse
Travel speed (3300 rpm)	
First	2.4 km/h (1.5 mile/h)
Second	3.7 km/h (2.3 mile/h)
Third	5.7 km/h (3.5 mile/h)
Fourth	7.0 km/h (4.3 mile/h)
Fifth	7.9 km/h (4.9 mile/h)
Reverse	2.8 km/h (1.7 mile/h)
Fuel tank capacity	2.0 ℓ (0.53 US gal)
Battery	12V 22AH

NOTE: Specifications are subject to change without notice.

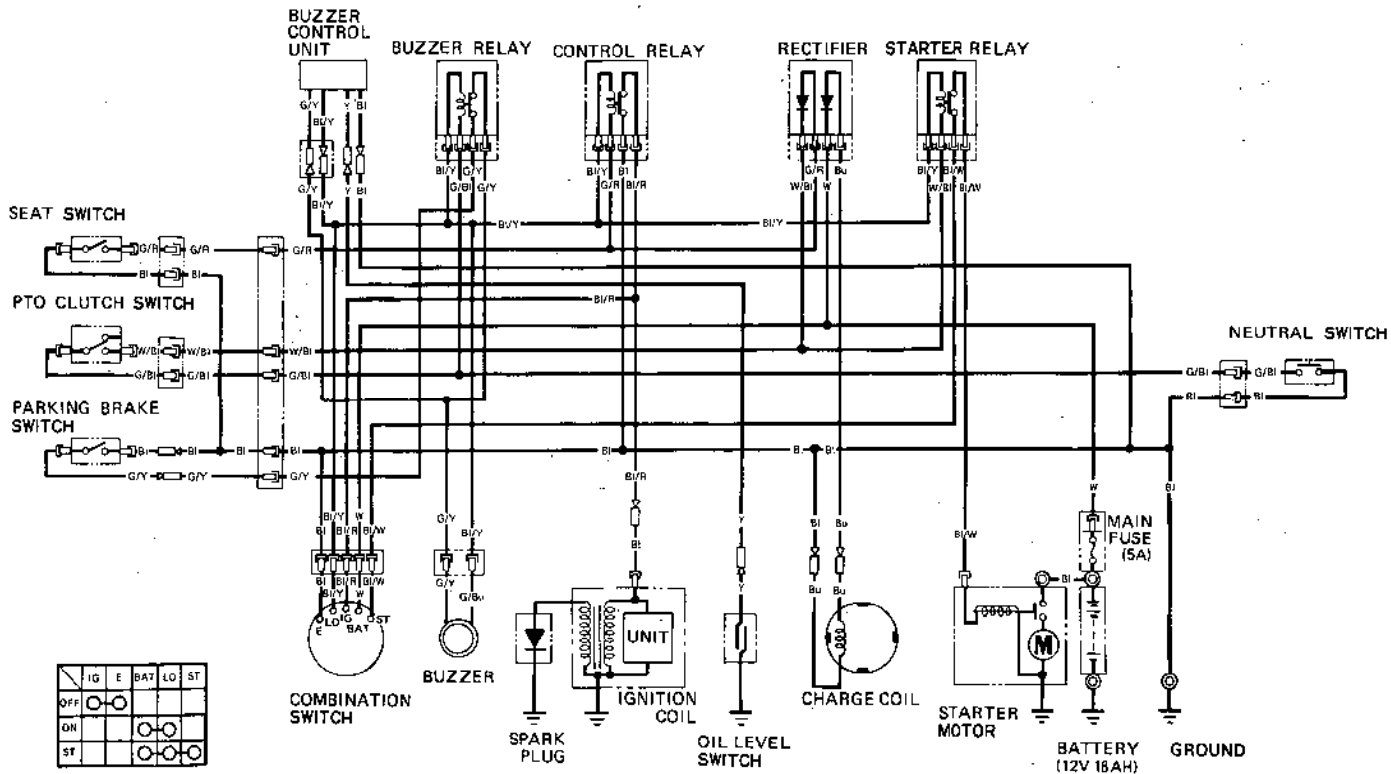

	IG	E	BAT	LO	ST
OFF	○	○			
ON			○	○	
ST					○

BI	BLACK	Br	BROWN
Y	YELLOW	O	ORANGE
Bu	BLUE	Lb	LIGHT BLUE
G	GREEN	Lg	LIGHT GREEN
R	RED	P	PINK
W	WHITE	Gr	GRAY

0030Z-751-7000

11. WARRANTY SERVICE

Owner Satisfaction

Your satisfaction and goodwill are important to your dealer and to us. All Honda warranty details are explained in the Distributor's Limited Warranty. Normally, any problems concerning the product will be handled by your dealer's service department. If you have a warranty problem that has not been handled to your satisfaction, we suggest you take the following action:

- Discuss your problem with a member of dealership management. Often complaints can be quickly resolved at that level. If the problem has already been reviewed with the Service Manager, contact the owner of the dealership or the General Manager.
- If your problem still has not been resolved to your satisfaction, contact the Power Equipment Customer Relations Department of American Honda Motor Co., Inc.

American Honda Motor Co., Inc.
Power Equipment Customer Relations Department
P.O. Box 50
Gardena, California 90247-0805
Telephone: (213) 604-2400

We will need the following information in order to assist you:

- Your name, address, and telephone number
- Product model and serial number
- Date of purchase
- Dealer name and address
- Nature of the problem

After reviewing all the facts involved, you will be advised of what action can be taken. Please bear in mind that your problem will likely be resolved at the dealership, using the dealer's facilities, equipment, and personnel, so it is very important that your initial contact be with the dealer.

Your purchase of a Honda product is greatly appreciated by both your dealer and American Honda Motor Co., Inc. We want to assist you in every way possible to assure your complete satisfaction with your purchase.

Current customer service contact information:

United States, Puerto Rico, and U.S. Virgin Islands:

Honda Power Equipment dealership personnel are trained professionals. They should be able to answer any question you may have. If you encounter a problem that your dealer does not solve to your satisfaction, please discuss it with the dealership's management. The Service Manager or General Manager can help. Almost all problems are solved in this way.

If you are dissatisfied with the decision made by the dealership's management, contact the Honda Power Equipment Customer Relations Office. You can write:

American Honda Motor Co., Inc.
Power Equipment Division
Customer Relations Office
4900 Marconi Drive
Alpharetta, GA 30005-8847

Or telephone: (770) 497-6400 M-F, 8:30 am - 7:00 pm EST

When you write or call, please provide the following information:

- Model and serial numbers
- Name of the dealer who sold the Honda power equipment to you
- Name and address of the dealer who services your equipment
- Date of purchase
- Your name, address, and telephone number
- A detailed description of the problem

MEMO

MEMO

MEMO

MEMO

HONDA

P/N 31751703
00X31-751-7030



Printed on
Recycled Paper

KINKO'S 50.2003.04
PRINTED IN U.S.A.