

**HONDA**  
**SNOWBLOWER**  
**HS55**



**OWNER'S MANUAL**

---

Thank you for purchasing a Honda snowblower.

This manual covers operation and maintenance of the HS55 snowblower. All information in this publication is based on the latest product information available at the time of approval for printing.

Honda Motor Co., Ltd. reserves the right to make changes at any time without notice and without incurring any obligation.

No part of this publication may be reproduced without written permission.

This manual should be considered a permanent part of the snowblower and remain with the snowblower when sold.

Pay special attention to statements preceded by the following words:

 **WARNING** Indicates a strong possibility of severe personal injury or loss of life if instructions are not followed.

**CAUTION:** Indicates a possibility of personal injury or equipment damage if instructions are not followed.

**NOTE:** Gives helpful information.

If a problem should arise, or if you have any questions about the snowblower consult an authorized Honda dealer.

 **WARNING** The Honda snowblower is designed to give safe and dependable service if operated according to instructions. Read and understand the Owner's Manual before operating the snowblower. Failure to do so could result in personal injury or equipment damage.

# CONTENTS

---

1. SAFETY INSTRUCTIONS .....	3
2. WARNING LABEL LOCATION .....	5
3. COMPONENT IDENTIFICATION AND FUNCTION.....	6
ENGINE SWITCH .....	8
FUEL VALVE.....	8
CHOKE LEVER .....	9
STARTER GRIP .....	9
THROTTLE LEVER (ENGINE SPEED).....	10
SHIFT LEVER .....	10
AUGER CLUTCH LEVER AND DRIVE CLUTCH LEVER.....	11
CHUTE CRANK .....	12
CHUTE GUIDE.....	12
SKID PLATE.....	13
HEIGHT ADJUSTMENT PEDAL (TRACK MODEL ONLY) .....	14
4. PRE-OPERATION CHECK .....	15
FUEL LEVEL.....	15
ENGINE OIL LEVEL.....	16
5. STARTING THE ENGINE .....	17
6. SNOWBLOWER OPERATION.....	20
7. STOPPING THE ENGINE .....	22
8. MAINTENANCE .....	23
MAINTENANCE SCHEDULE .....	24
TOOL KIT .....	25
ENGINE OIL CHANGE.....	26
SPARK PLUG SERVICE.....	27
TRACK ADJUSTMENT (TRACK MODEL ONLY) .....	28
9. STORAGE .....	29
10. TROUBLESHOOTING .....	32
11. SPECIFICATIONS .....	33
12. WARRANTY SERVICE.....	34

# 1. SAFETY INSTRUCTIONS

## WARNING

To ensure safe operation—

- Read this owner's manual thoroughly and understand the operating procedure before using the snowblower. Never permit anyone to operate the snowblower without proper instructions.
- Do not allow children to operate the snowblower. Keep children and pets away from the area of operation.
- Be properly dressed in winter clothing. Wear slip-proof winter boots.
- Before operating the snowblower, inspect the area you are going to clear of snow. Remove doormats, sleds, sticks, boards, wires and other obstacles before using the snowblower.
- Never use the snowblower to clear snow from a gravel road or drive, as rocks may be picked up and thrown.
- Don't use the snowblower where visibility is bad, or at nighttime under poor lighting conditions.
- Inspect the snowblower before operating it. If it is malfunctioning, repair it before operating it.
- Be careful in turning the direction of the snowblower, while operating it on a slope. Do not use the snowblower to remove snow from roofs and from steep slopes.
- The snowblower may not stand by itself on slopes; do not leave it unattended.

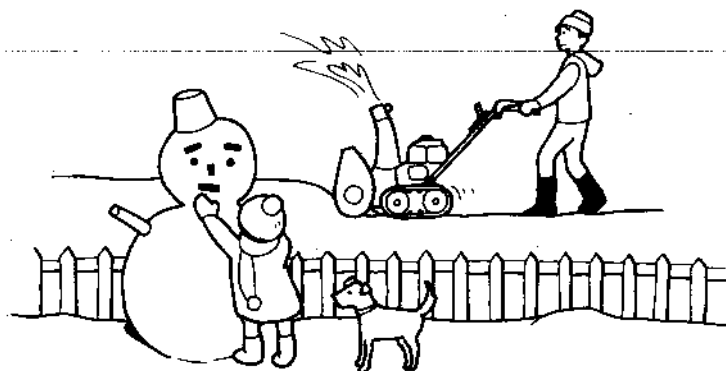

**WARNING**

- **Adjust the snow chute to avoid hitting bystanders, windows, etc. with thrown snow. Stay clear of the discharge opening.**
- **While operating the snowblower, always hold the handle firmly and walk, don't run.**
- **If people or pets suddenly appear in front of the snowblower, while it is in operation, immediately release the auger and drive clutch levers.**
- **If you hit an obstacle while operating the snowblower, stop the engine immediately and check the machinery for damage. Don't operate a damaged machine because you may cause an accident.**
- **Before unclogging the discharge guide, turn the engine OFF.**
- **Exhaust gas contains poisonous carbon monoxide.**  
Never run the snowblower in an enclosed area.  
Be sure to provide adequate ventilation.
- **Gasoline is extremely flammable and explosive under certain conditions. Refuel in a well ventilated area with the engine stopped.**
- **When transporting the snowblower, turn the fuel valve OFF and keep the snowblower level to prevent fuel spillage.**

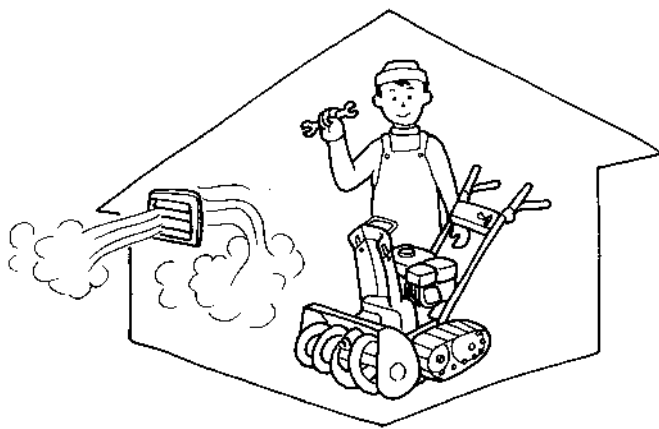

## 2. WARNING LABEL LOCATION

**WARNING**

**DO NOT OVERFILL.**



**WARNING**

- KEEP HANDS OUT OF DISCHARGE CHUTE.
- KEEP CLEAR OF THIS COLLECTOR AND DISCHARGE CHUTE WHILE ENGINE IS RUNNING.
- DO NOT DIRECT DISCHARGE AT BYSTANDERS OR WINDOW.
- BEFORE LEAVING OPERATOR'S POSITION
  1. DISENGAGE THROWER CLUTCH.
  2. STOP ENGINE.
- STOP ENGINE, WAIT FOR ALL MOVEMENT TO STOP AND REMOVE SPARK PLUG IGNITION WIRE BEFORE SERVICING MACHINE.

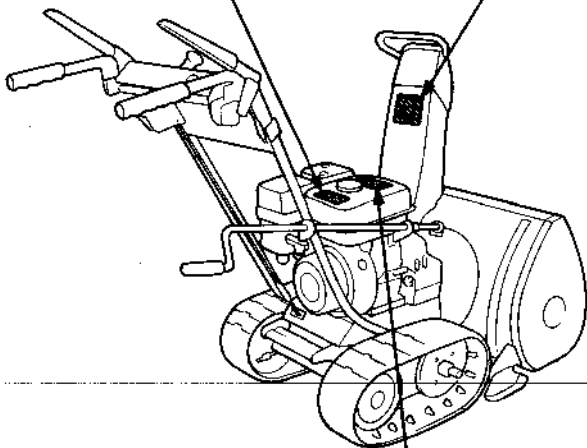

- CHECK FOR SPILLED FUEL OR FUEL LEAKS. STOP ENGINE BEFORE REFUELING.
- CONTRÔLER QU'IL N'Y A NI FUITE NI ESSENCE REPANDUE SUR L'APPAREIL. ARRÊTER LE MOTEUR AVANT DE REFAIRE LE PLEIN.
- INSPECCIONAR PARA COMBUSTIBLE DERRAMADO O ESCAPE. PARAR MOTOR ANTES DE ECHAR.

### 3. COMPONENT IDENTIFICATION AND FUNCTION

#### 《WHEEL TYPE》

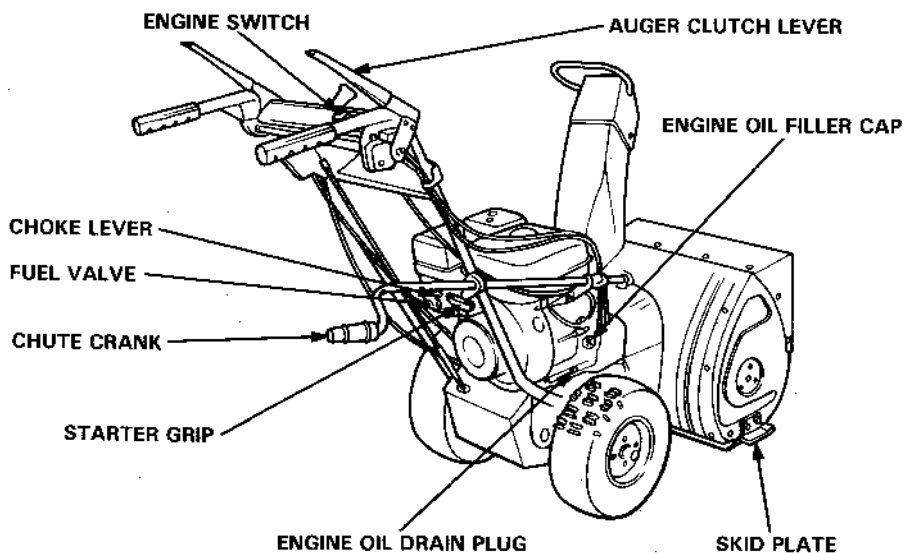
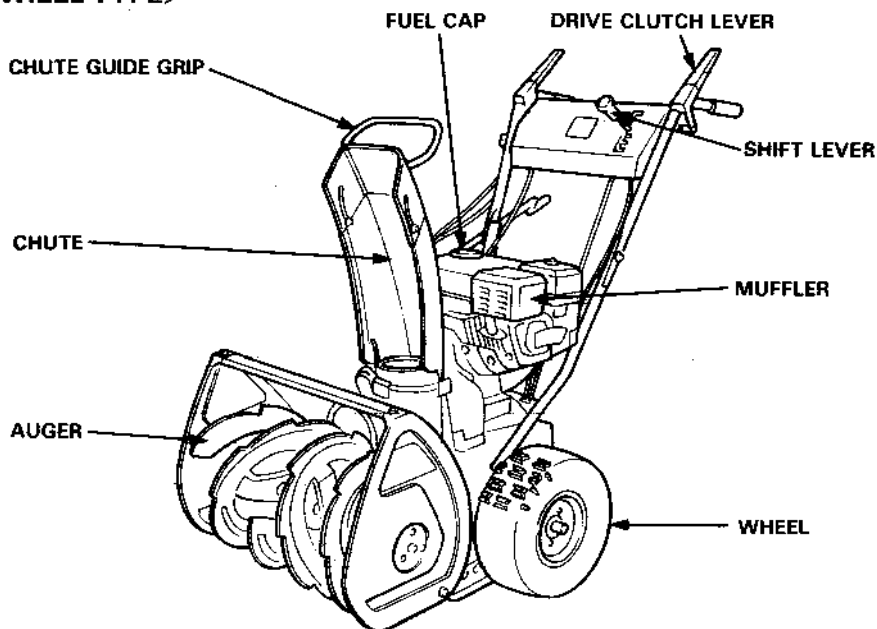

◀TRACK TYPE▶

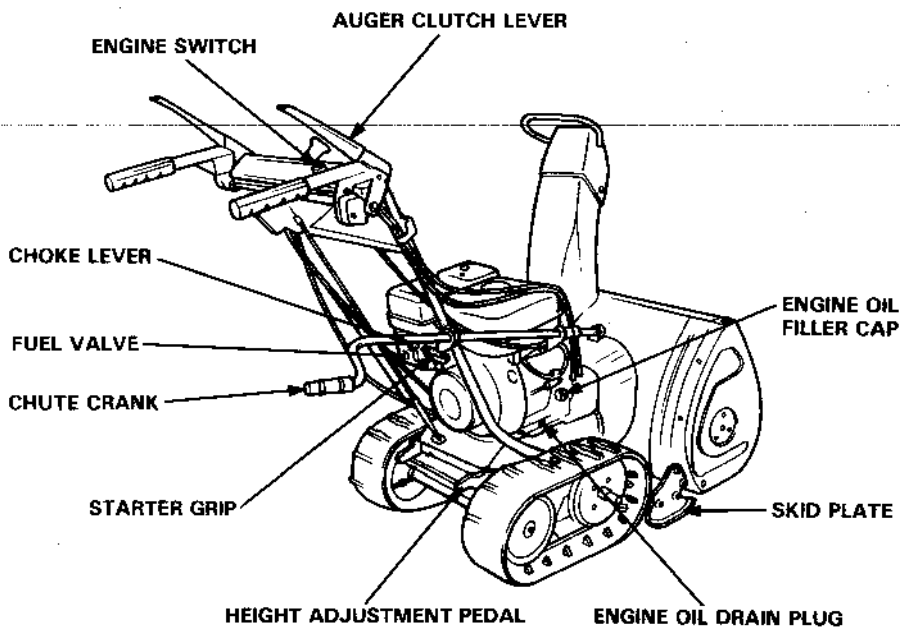
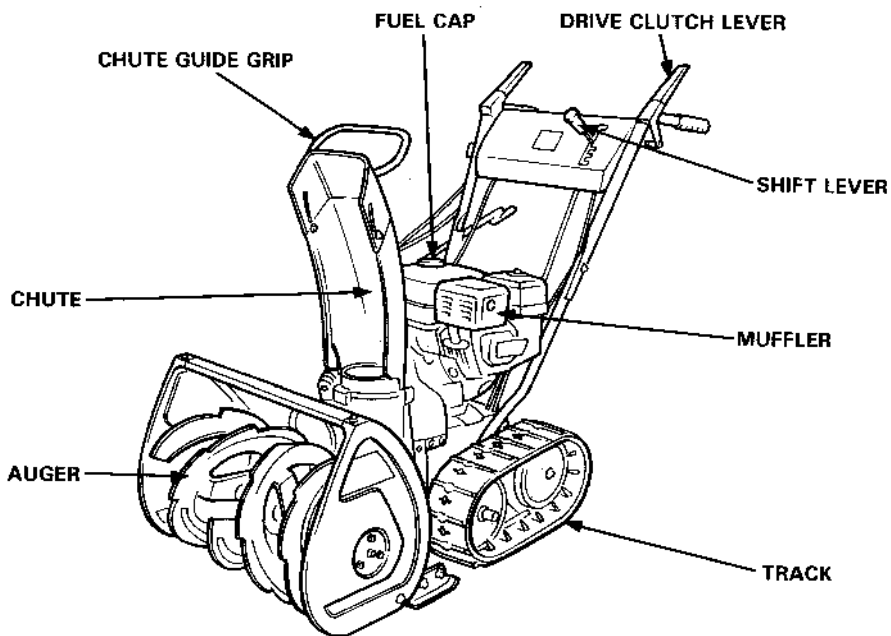



---

## ENGINE SWITCH

Use the engine switch to START and STOP the engine.

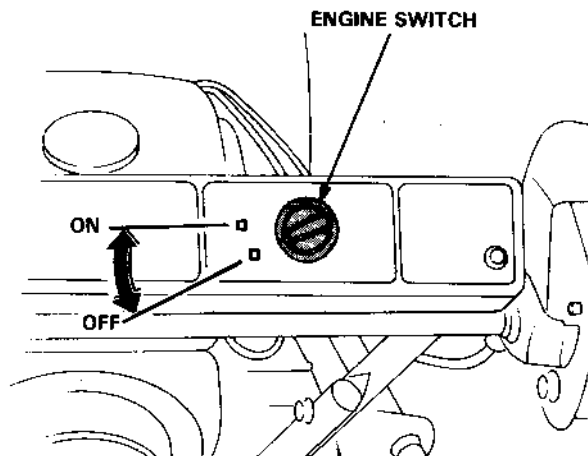

## FUEL VALVE

The fuel valve opens and closes the fuel line leading from the fuel tank to the carburetor. Make sure that the valve is positioned exactly at either the ON or OFF position.

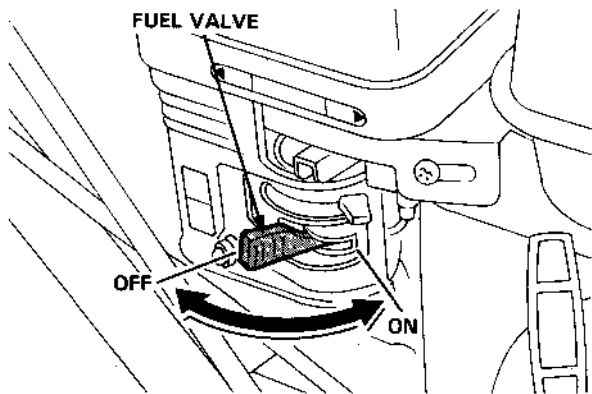

**NOTE:** Before transporting the snowblower, be sure to turn the fuel valve to OFF to prevent possible fuel leaks.

## CHOKE LEVER

Use the choke lever when the engine is cold or difficult to start.

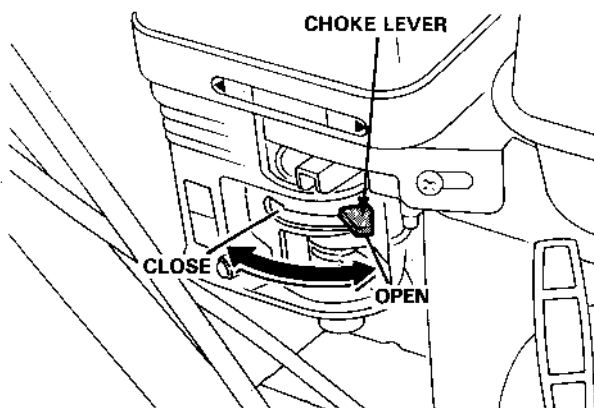

## STARTER GRIP

Pull this grip to start the engine.

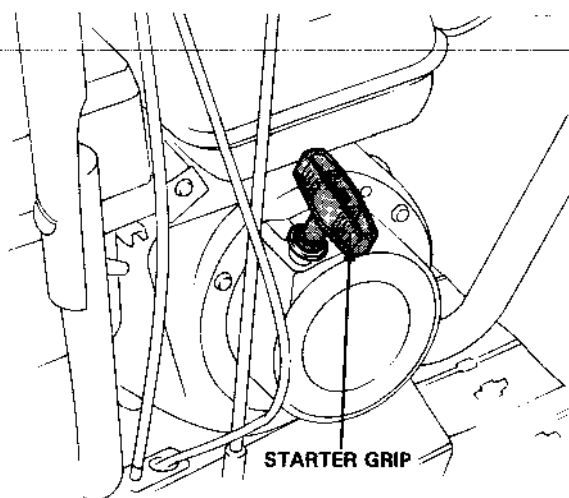

---

## THROTTLE LEVER (ENGINE SPEED)

Use the throttle lever to select engine speed. In normal operation, use the FAST position.

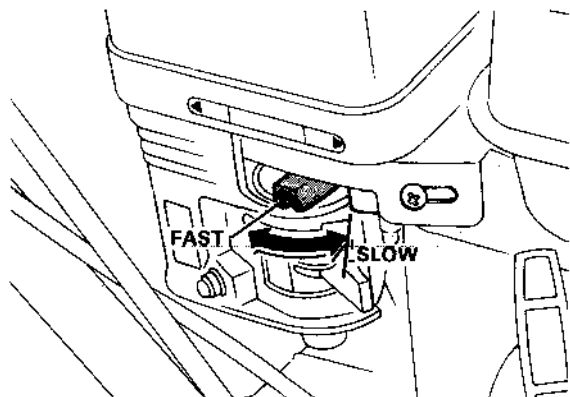

## SHIFT LEVER

Use the shift lever to select drive speed or direction.

- 1: LOW SPEED
- 2: MEDIUM SPEED
- 3: HIGH SPEED
- R: REVERSE

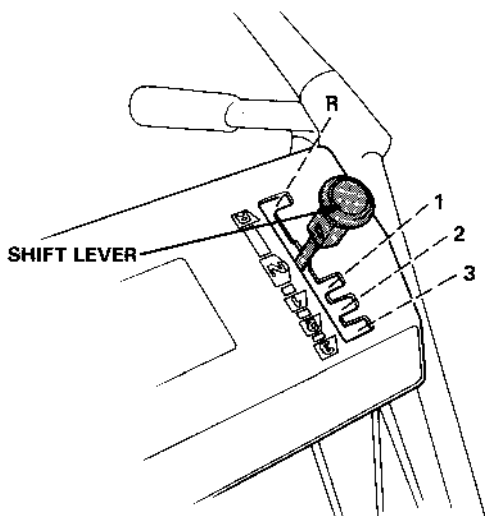

## AUGER CLUTCH LEVER AND DRIVE CLUTCH LEVER

Use these controls to engage the snow blowing mechanism and/or the drive mechanism.

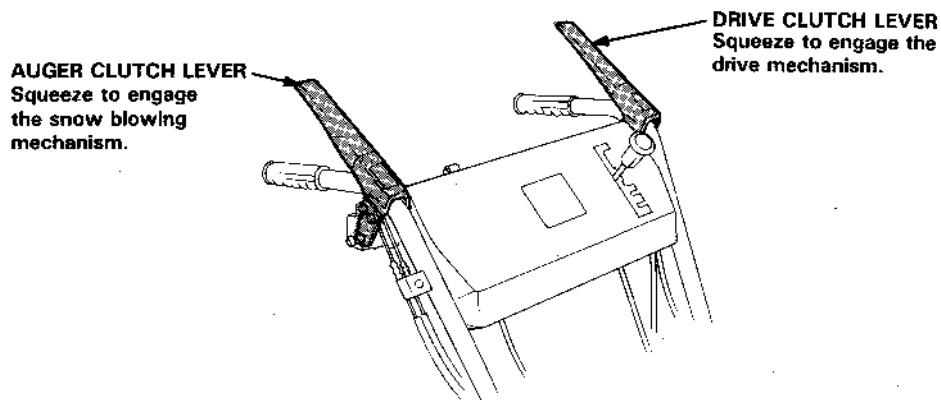

**NOTE:** When both levers are squeezed, the drive clutch lever locks the auger clutch lever down. Releasing the drive clutch lever then unlocks and releases the auger clutch lever.

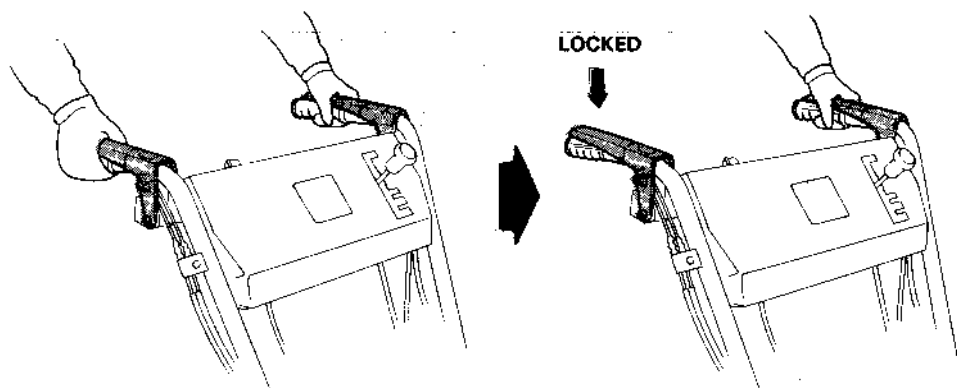

**Both levers squeezed**

The auger clutch lever remains locked down so long as one hand continues to squeeze the drive clutch lever.

---

## CHUTE CRANK

Use the chute crank to turn the snow discharge chute right or left.

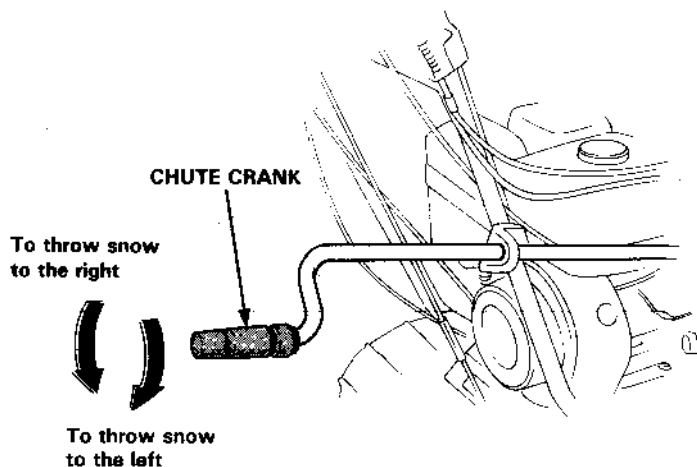

## CHUTE GUIDE

The chute guide controls the snow discharge angle.

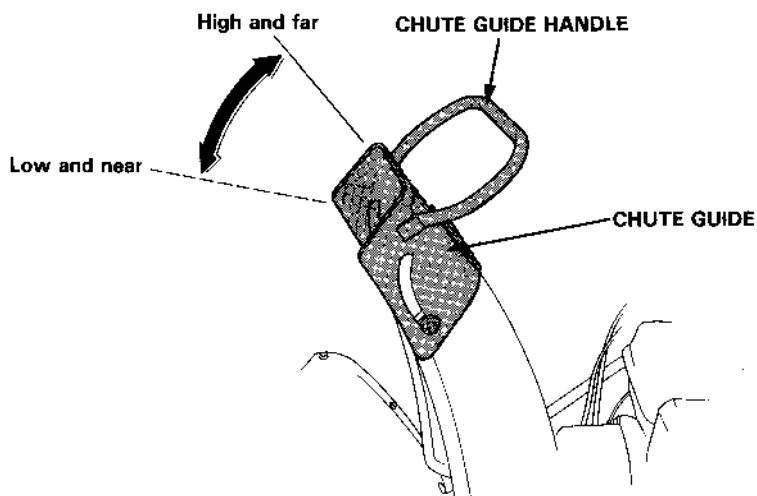

## SKID PLATE

Adjust the skid plates for the auger housing ground clearance best suited to your snow removal conditions.

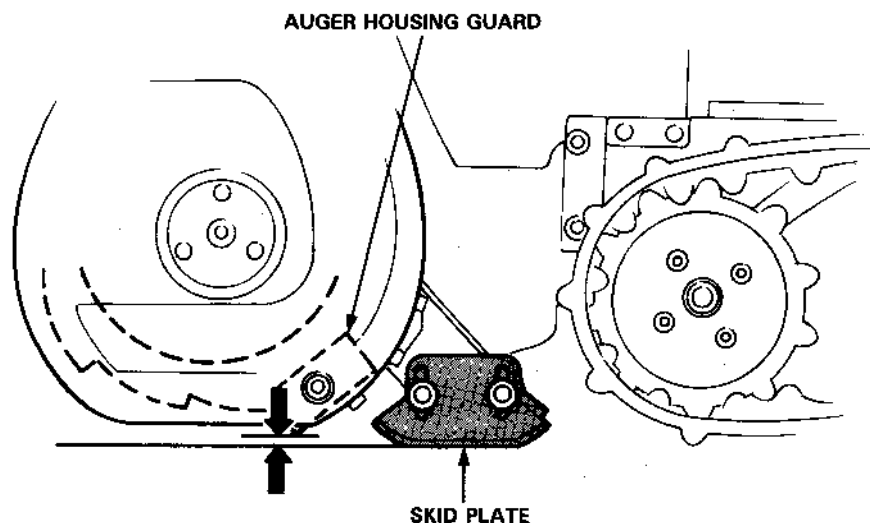

SNOW REMOVAL CONDITIONS	RECOMMENDED AUGER HOUSING GROUND CLEARANCE
For general use	6– 8 mm (0.24–0.31 in)
For use on uneven surfaces	10–30 mm (0.39–1.18 in)
For use on flat surfaces	0– 5 mm (0–0.20 in)

NOTE: Track model only – The position of the height adjustment pedal (p. 14) also affects auger housing ground clearance. Set the height adjustment pedal in the middle position before adjusting the skid plates.

---

## HEIGHT ADJUSTMENT PEDAL (Track model only)

Use the pedal for adjusting the height and angle of the machine in relation to the tracks.

1. Hold the handles and step on the pedal.
2. Raise or lower the machine to the desired position and release the pedal.

**LOW** : Hard snow or fine finish

**MIDDLE**: Normal use

**HIGH** : Deep snow or for transporting the HS55.

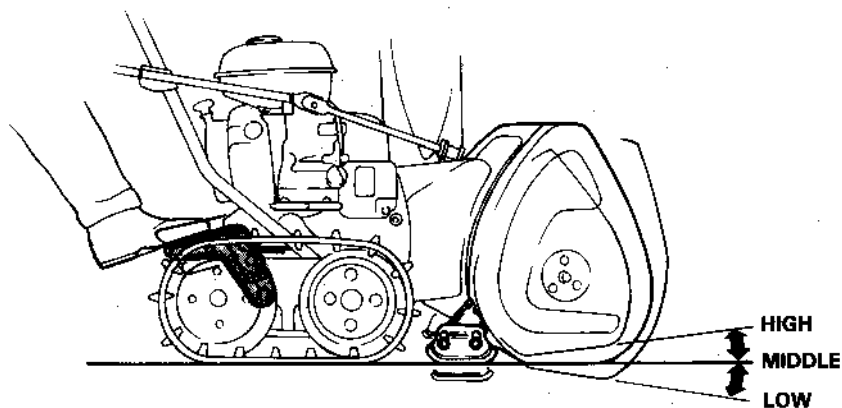

## 4. PRE-OPERATION CHECK

### FUEL LEVEL

#### Inspection:

Unscrew the fuel cap. Check the fuel level.

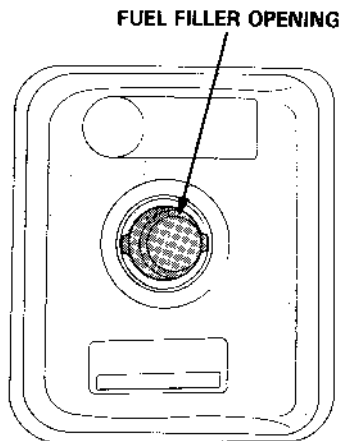

#### Refueling:

Use any regular grade automotive gasoline (unleaded gasoline is preferred) with a pump octane rating of 86 or higher. Never use an oil/gasoline mixture. Prevent dirt, dust or water from entering the fuel tank.

**CAUTION:** Gasoline substitutes are not recommended: they may be harmful to the fuel system components.

**FUEL TANK CAPACITY:** 3.5ℓ (0.92 US gal, 0.77 Imp gal)

#### WARNING

- Gasoline is extremely flammable and explosive under certain conditions. Refuel in a well ventilated area with the engine stopped.
- Do not smoke or allow flames or sparks in the area where the snow blower is being refueled or where gasoline is stored.
- Be careful not to spill fuel when refueling. Fuel vapor or spilled fuel may ignite. Make sure the area is dry of spilled fuel before starting the engine.
- Do not overfill the tank (there should be no fuel in the filler neck). After refueling, make sure the fuel cap is closed securely.
- Do not refuel in snow because snow will get into the fuel tank and cause an engine malfunction.



## ENGINE OIL LEVEL

### Inspection:

With the snowblower on a level surface, remove the oil filler cap and check the oil level.

If the level is low, fill to the top of the oil filler neck with the recommended oil.

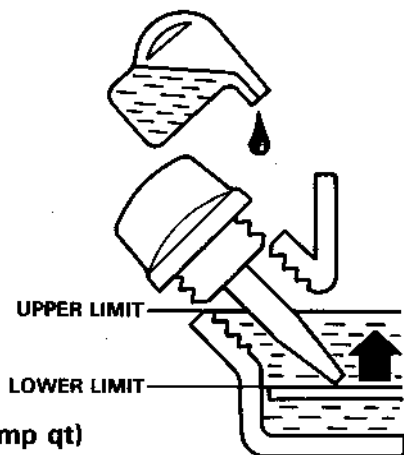
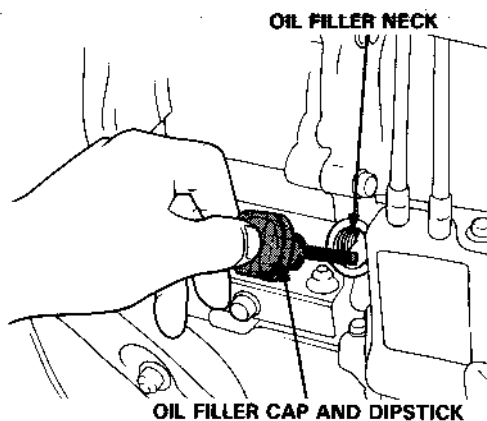
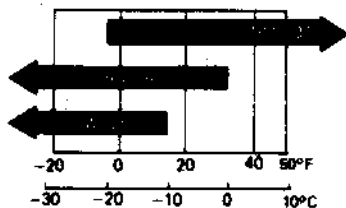

**OIL CAPACITY:** 0.6l (0.63 US qt, 0.53 Imp qt)

### RECOMMENDED OIL:

Use high detergent, premium quality motor oil certified to meet or exceed U.S. automobile manufacturers' requirements for service classification SE or SF (Motor oils classified SE or SF will show this designation on the container.) Select the appropriate oil viscosity for the average temperature in your area, as shown in this chart. SAE 5W-30 is recommended for general, all-temperature use.

### CAUTION:

- Engine oil is a major factor affecting engine performance and service life. Non-detergent or vegetable oils are not recommended.
- Running the engine with insufficient oil can cause serious engine damage.

## 5. STARTING THE ENGINE

1. Turn the engine switch to the ON position.

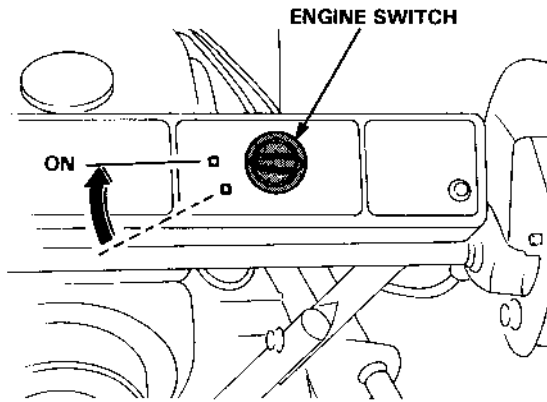

2. Turn the fuel valve to the ON position.

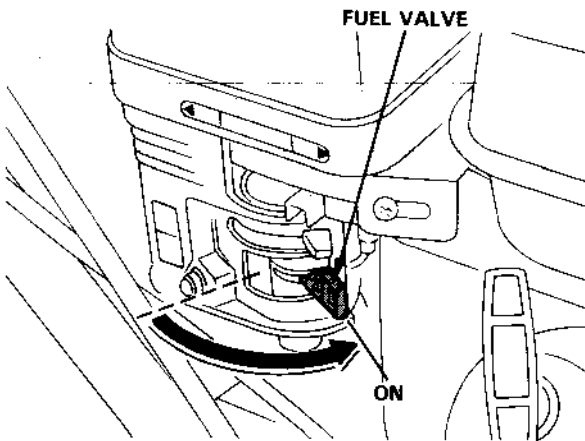

3. In cold weather and when the engine is cold, turn the choke lever to the CLOSE position.

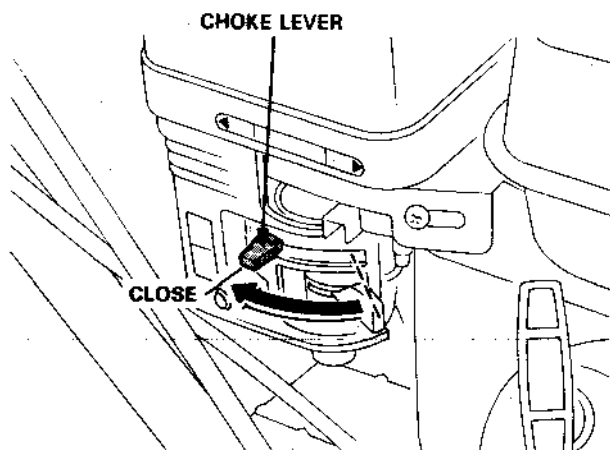

4. Pull the starter grip lightly until you feel resistance, then pull briskly.

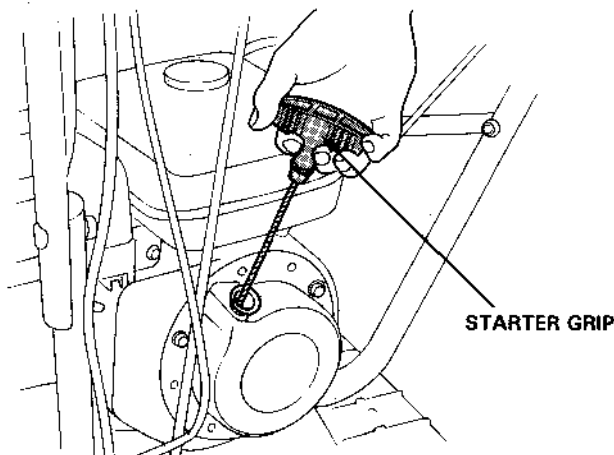

**NOTE:** Don't allow the rope to snap back; return it gently by hand. Otherwise, the starting mechanism might be damaged. While the engine is in operation, don't pull the starter grip or damage may result.

5. Let the engine warm up for several minutes. If the choke has been turned to the **CLOSE** position, return it gradually to the **OPEN** position as the engine warms up.

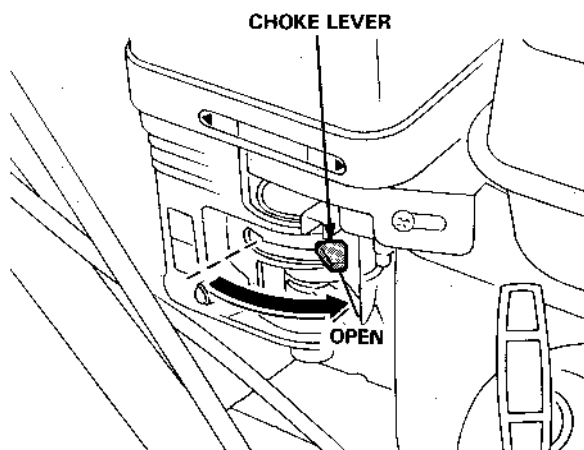

## 6. SNOWBLOWER OPERATION

---

1. Move the throttle lever (p. 10) to the FAST position for normal operation.
2. Move the shift lever (p. 10) to select the desired drive speed.

( DRIVE SPEED WITH THROTTLE  
LEVER IN THE FAST POSITION )

	Wheel type	Track type
1	0.43 m/s (1.41 ft/s)	0.28 m/s (0.92 ft/s)
2	0.74 m/s (2.43 ft/s)	0.48 m/s (1.57 ft/s)
3	1.01 m/s (3.31 ft/s)	1.10 m/s (3.61 ft/s)
R	0.68 m/s (2.23 ft/s)	0.74 m/s (2.43 ft/s)

**CAUTION:** Be sure to set the shift lever into the groove. Do not change direction while the machine is in motion.

**NOTE:** Low speed (1) is recommended for removing deep or hard-packed snow.

3. Track model only — Use the height adjustment pedal (p. 14) to adjust the height and angle of the machine.
4. Adjust the chute direction (p. 12) and chute guide angle (p. 12).
5. Squeeze the auger clutch lever and drive clutch lever (p. 11) to propel the machine and commence snow clearing.

### High Altitude Operation

When operating this snowblower at high altitude, the air-fuel mixture becomes overly rich; engine performance may be reduced and fuel consumption increased.

See your authorized HONDA dealer for high altitude adjustment.

**NOTE:**

- To move the machine without engaging the snow-blowing mechanism, squeeze the drive clutch lever only. Do this when moving the machine to or from the area to be cleared.
- To engage the snow-blowing mechanism without using the drive mechanism, squeeze the auger clutch lever only. Do this if you wish to maneuver the machine manually while clearing snow.
- Squeeze both levers to propel the machine and clear snow simultaneously. When both levers are squeezed, the drive clutch lever locks the auger clutch lever down (p. 11). The auger clutch lever remains locked down so long as one hand continues to squeeze the drive clutch lever. Releasing the drive clutch lever then unlocks and releases the auger clutch lever.
- If the snow is deeper than the height of the auger, move the machine back and forth to remove snow gradually.
- For best efficiency, clear snow before it melts, refreezes and hardens.

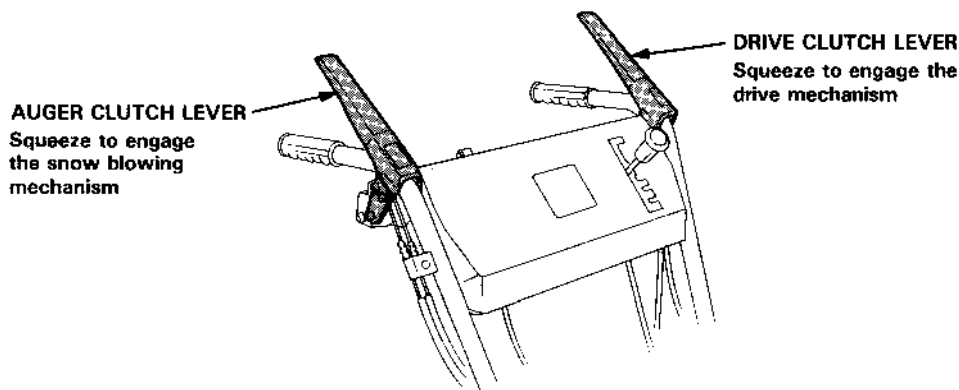

## 7. STOPPING THE ENGINE

---

1. Turn the throttle lever to the SLOW position and turn the engine switch to the OFF position.

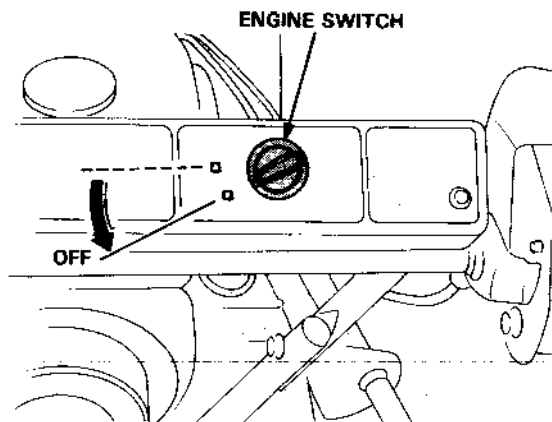

2. Turn the fuel valve to the OFF position.

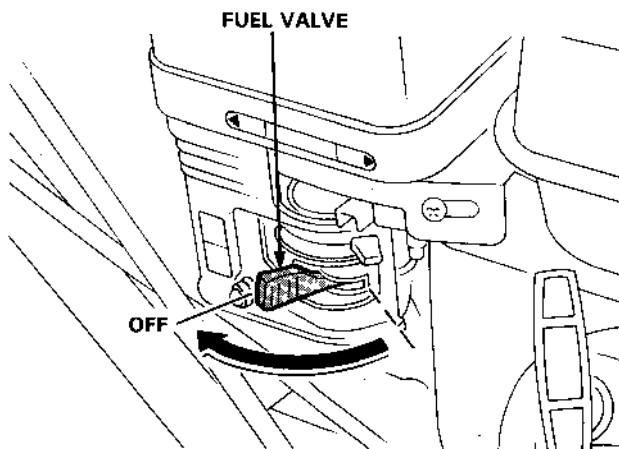

The purpose of inspection and maintenance is to keep the snowblower in the best operating condition.

Inspect or service as scheduled in the table on the next page.

 **WARNING** Shut off the engine before performing inspection and maintenance, and remove the spark plug wire from the plug so the engine cannot be started. If the engine must be run, make sure the area is well ventilated. The exhaust contains poisonous carbon monoxide gas.

### CAUTION:

- Place the snowblower on a level surface before performing inspection and maintenance.
- Use only genuine HONDA parts or their equivalent. The use of replacement parts which are not of equivalent quality may damage the snowblower.



## MAINTENANCE SCHEDULE

SERVICE PERIOD		EACH USE	EVERY YEAR		EVERY 5 YEARS
			BEFORE OPERATION	BEFORE STORAGE	
Engine oil	Check level	○			
	Change	First 20 hours operation			
Auger and blower	Check	○	○		
	Apply oil			○	
Spark plug	Clean-Readjust		○		
Auger clutch cable	Adjust		○		○ (1) (2)
Drive clutch cable	Adjust		○		○ (1) (2)
Track	Adjust		○		
Drive belt	Check		○		
	Change				○ (1) (2)
Nuts, bolts, fasteners	Check		○		
Fuel tank and carburetor	Drain			○	
Friction disc rubber	Check			○ (1) (2)	
Fuel line	Check (Replace if necessary)		Every 3 years		
Valve clearance	Check-Readjust				○ (2)
Fuel tank	Clean				○ (2)

- (1) These parts may require more frequent inspection and replacement under heavy use.
- (2) These items should be serviced by an authorized Honda dealer, unless the owner has the proper tools and is mechanically proficient. See the Honda Shop Manual for service information.

---

## TOOL KIT

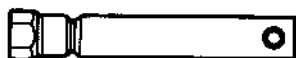

SPARK PLUG WRENCH



WRENCH HANDLE

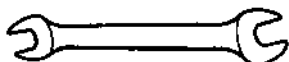

14 X 10 mm WRENCH

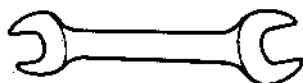

14 X 12 mm WRENCH

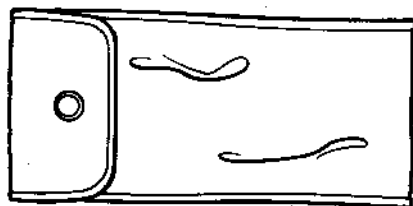

TOOL BAG

## ENGINE OIL CHANGE

Drain the oil while the engine is still warm to assure rapid and complete draining.

1. Remove the drain plug and filler cap, and drain the oil. Retighten the plug securely.
2. Fill the crankcase with the recommended oil (see page 16) and check the level.

**OIL CAPACITY: 0.6<sup>l</sup> (0.63 US qt, 0.53 Imp qt)**

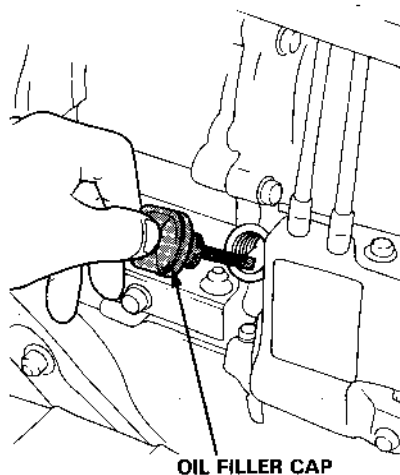
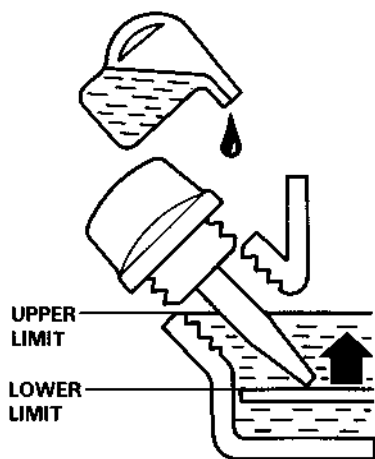
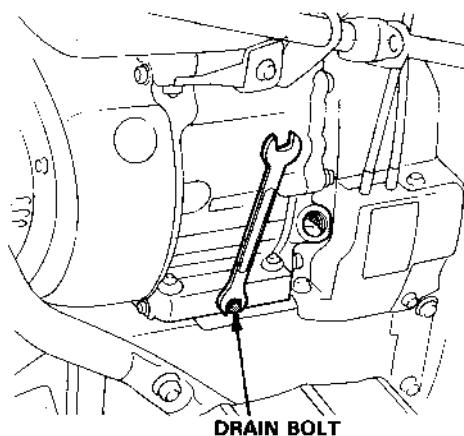

## SPARK PLUG SERVICE

### Recommended spark plug: BPR5ES (NGK)

To ensure proper engine operation, the spark plug must be properly gapped and free of deposits.

1. Remove the spark plug cap.
2. Use the wrench supplied in the tool kit to remove the spark plug.
3. Visually inspect the spark plug. Discard it if the insulator is cracked or chipped.
4. Measure the plug gap with a feeler gauge.  
The gap should be 0.7–0.8 mm (0.027–0.031 in). Correct as necessary by bending the side electrode.
5. Attach the plug washer. Thread the plug in by hand to prevent cross-threading.
6. Tighten a new spark plug 1/2 turn with the wrench to compress the washer.  
If you are reusing a plug, it should only take 1/8–1/4 turn after the plug seats.

### CAUTION:

- The spark plug must be securely tightened. An improperly tightened plug can become very hot and possibly damage the engine.
- Never use a spark plug with an improper heat range.

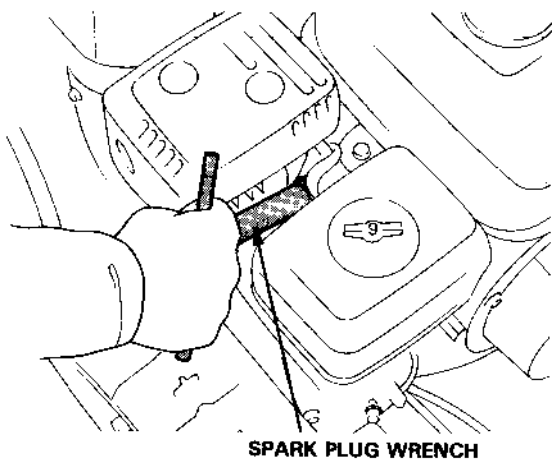

SPARK PLUG WRENCH

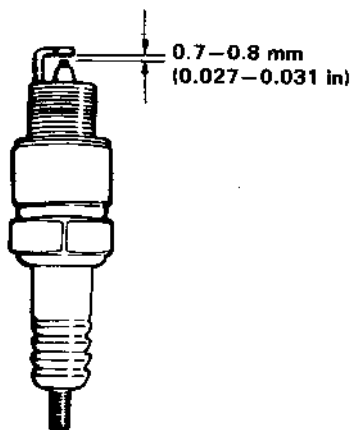

## TRACK-ADJUSTMENT (Track model only)

Clean and thaw the tracks before adjustment. The tracks cannot be correctly adjusted if clogged with snow or debris, or coated with ice.

Check track deflection midway between the wheels. When correctly adjusted, the track will deflect 19–25 mm (3/4–1 in) when pressed with a force of 15 Kg (33 lb).

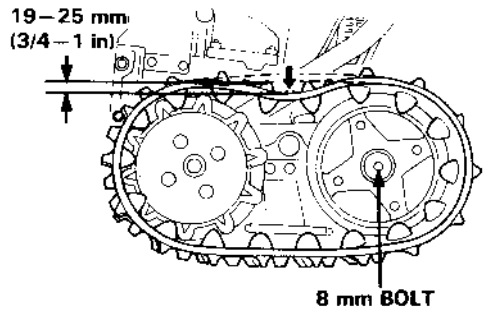

### Adjustment:

1. Loosen the 8 mm bolt at the center of each rear wheel.
2. Loosen the left and right tension bolt lock nuts at the rear axle, and turn the adjusting nuts to correctly tension both tracks.
3. After adjustment, retighten the lock nuts and rear wheel bolts.

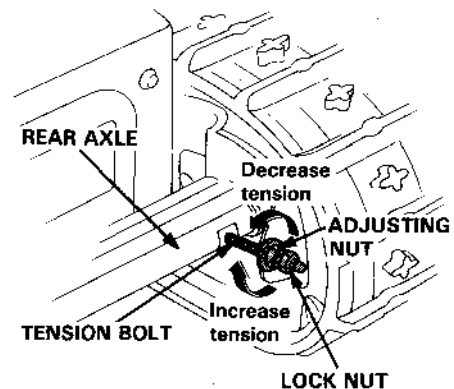

## 9. STORAGE

Before storing the snowblower for an extended period:

1. Be sure the storage area is free of excessive humidity and dust.
2. Drain the fuel—

**WARNING** Gasoline is extremely flammable and explosive under certain conditions. Do not smoke or allow flames or sparks in the area.

- a. Turn the fuel valve ON.

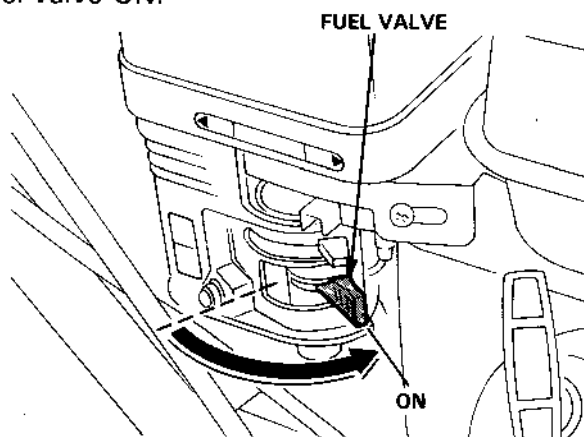

- b. Loosen the carburetor drain screw, and drain the gasoline into a suitable container. After draining, retighten the drain screw and turn the fuel valve OFF.

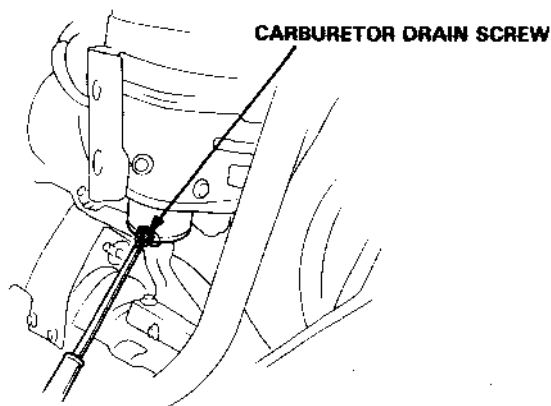

---

Remove the spark plug and pour three tablespoonsful of clean motor oil into the cylinder. Pull the starter rope slowly two or three times to distribute the oil. Reinstall the spark plug.

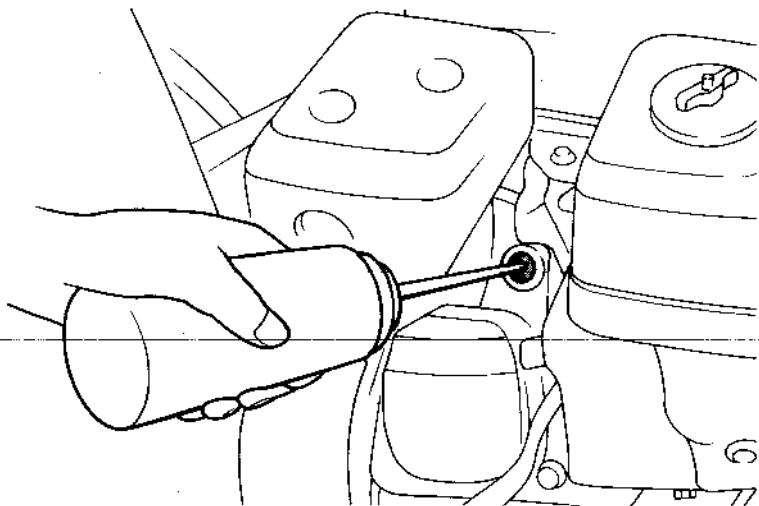

Pull the starter grip until resistance is felt. This closes the valves and protects them from dust and corrosion.

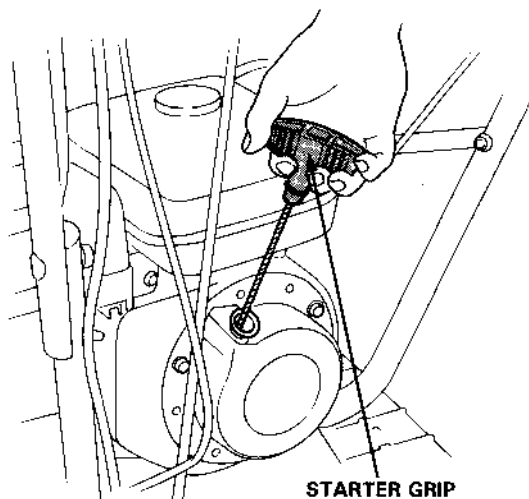

Apply oil to the following parts for lubrication and rust prevention.

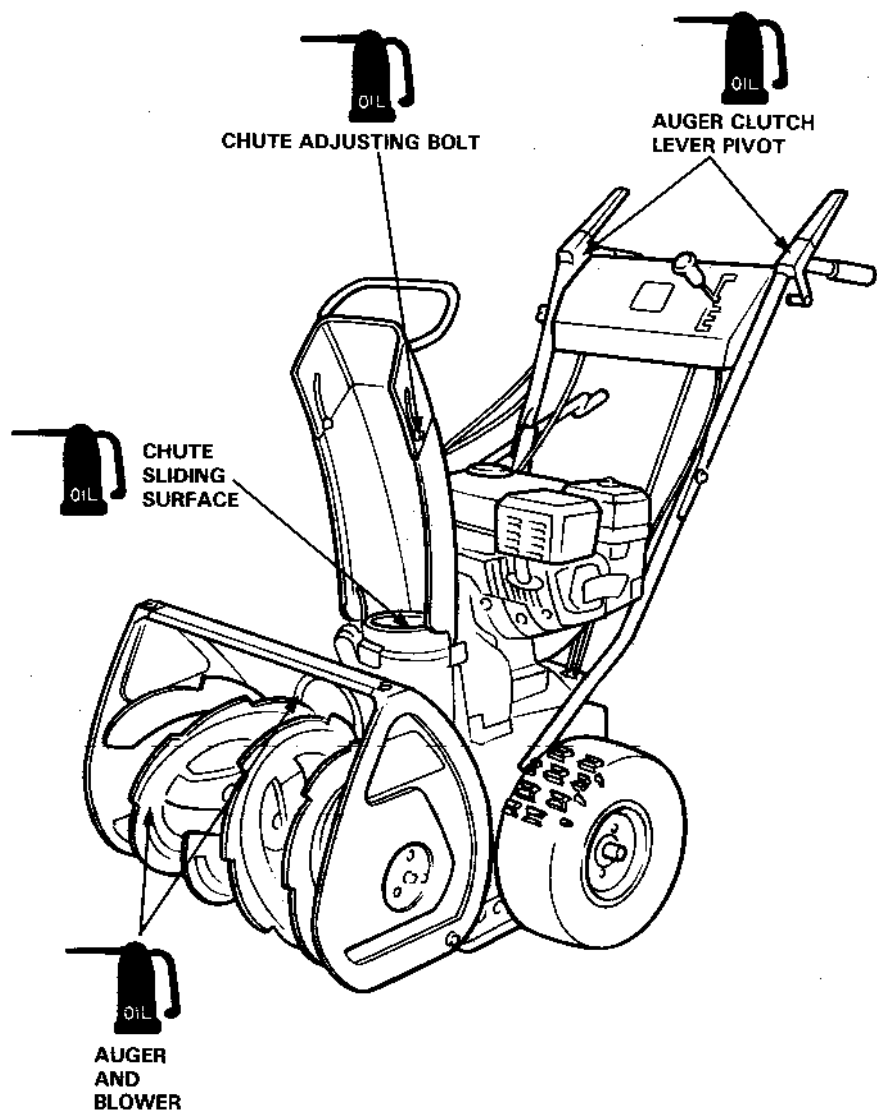



## 10. TROUBLESHOOTING

When the engine will not start:

1. Is there enough fuel?
2. Is the fuel valve on?
3. Is gasoline reaching the carburetor?

To check, loosen the drain screw with the fuel valve on.

**WARNING** If any fuel is spilled, make sure the area is dry before testing the spark plug or starting the engine. Fuel vapor or spilled fuel can ignite.

4. Is the engine switch on?
5. Is there a spark at the spark plug?
  - a. Remove the spark plug cap. Clean any dirt from around the spark plug base, then remove the spark plug.
  - b. Install the spark plug in the plug cap.
  - c. Turn the engine switch on.
  - d. Grounding the side electrode to any engine ground, crank the engine to see if sparks jump across the gap.
  - e. If there are no sparks, replace the plug.If OK, try to start the engine according to the instructions.
6. If the engine still does not start, take the snowblower to the dealer.

When the auger or blower will not operate:

Check the shear bolts and replace if broken off.

Secure the shear bolts with 6 mm nuts.

Three spare shear bolts are supplied with the HS55 snowblower.

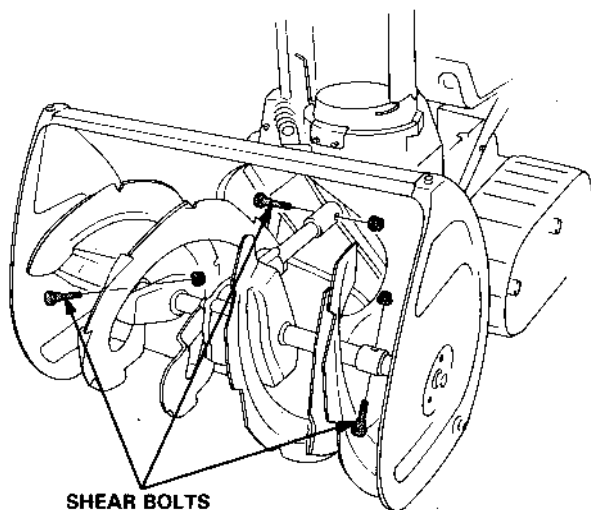

SHEAR BOLTS

# 11. SPECIFICATIONS

## Engine

Model:	HONDA GX140
Maximum output:	5.5 HP/4200 r.p.m
Displacement:	144 cm <sup>3</sup> (8.8 cu. in)
Bore x stroke:	64 X 45 mm (2.5 X 1.8 in)
Starting method:	Recoil starter
Ignition system:	Transistorized magneto
Oil capacity:	0.6ℓ (0.63 US qt, 0.53 Imp qt)
Fuel tank capacity:	3.5ℓ (0.92 US gal, 0.77 Imp gal)
Spark plug:	BPR5ES (NGK)

## Frame

Items	Type	Wheel type	Track type
Overall length		1310 mm (51.6 in)	1235 mm (48.6 in)
Overall width		663 mm (26.1 in)	550 mm (21.7 in)
Overall height		1029 mm (40.5 in)	975 mm (38.4 in)
Dry weight		80 kg (173 lb)	76 kg (168 lb)
Width of snow clearance		605 mm (23.8 in)	550 mm (21.7 in)
Height of snow clearance		470 mm (18.5 in)	415 mm (16.3 in)
Snow throwing distance (differs according to the kind of snow)		Max. 12 m (39.4 ft)	Max. 12 m (39.4 ft)
Clearing capacity		37 Ton/hour	35 Ton/hour
Continuous operating time		3 hours	3 hours

## 12. WARRANTY SERVICE

---

### Owner Satisfaction

Your satisfaction and goodwill are important to your dealer and to us. Normally, any problems with the product will be handled by your dealer's service department. Sometimes, however, despite the best intentions of all concerned, misunderstandings can occur. If your problem has not been handled to your satisfaction, we suggest you take the following action:

- Discuss your problem with a member of dealership management. Of ten complaints can be quickly resolved at that level. If the problem has already been reviewed with the Service Manager, contact the owner of the dealership or the General Manager.
- If your problem still has not been resolved to your satisfaction, contact the ~~Customer Relations Department at the regional office of American Honda Motor Co., Inc.~~ in your area. Regional office locations are shown on the following page. We will need the following information in order to assist you:
  - Your name, address, and telephone number
  - Product model and serial number
  - Date of purchase
  - Dealer name and address
  - Nature of the problem

After reviewing all the facts involved, you will be advised of what action can be taken. Please bear in mind that your problem will likely be resolved at the dealership, using the dealer's facilities, equipment, and personnel, so it is very important that your initial contact be with the dealer.

Your purchase of a Honda product is greatly appreciated by both the dealer and American Honda Motor Co., Inc. We want to assist you in every way possible to assure your complete satisfaction with your purchase.

## **Current customer service contact information:**

### **United States, Puerto Rico, and U.S. Virgin Islands:**

Honda Power Equipment dealership personnel are trained professionals. They should be able to answer any question you may have. If you encounter a problem that your dealer does not solve to your satisfaction, please discuss it with the dealership's management. The Service Manager or General Manager can help. Almost all problems are solved in this way.

If you are dissatisfied with the decision made by the dealership's management, contact the Honda Power Equipment Customer Relations Office. You can write:

American Honda Motor Co., Inc.  
Power Equipment Division  
Customer Relations Office  
4900 Marconi Drive  
Alpharetta, GA 30005-8847

Or telephone: (770) 497-6400 M-F, 8:30 am - 7:00 pm EST

When you write or call, please provide the following information:

- Model and serial numbers
- Name of the dealer who sold the Honda power equipment to you
- Name and address of the dealer who services your equipment
- Date of purchase
- Your name, address, and telephone number
- A detailed description of the problem

## Regional Office Locations

### **NORTHWEST REGIONAL OFFICE** (includes Alaska)

American Honda Motor Co., Inc.  
Customer Relations Department  
P.O. Box 30286  
Portland, Oregon 97220  
Telephone: (503) 256-1186

**MIDWEST REGIONAL OFFICE**  
American Honda Motor Co., Inc.  
Customer Relations Department  
P.O. Box 22  
Greendale, Wisconsin 53129  
Telephone: (414) 421-9300

**NORTHEAST REGIONAL OFFICE**  
American Honda Motor Co., Inc.  
Customer Relations Department  
P.O. Box 749  
Moorestown, New Jersey 08067  
Telephone: (609) 778-1100



### **WESTERN REGIONAL OFFICE** (includes Hawaii)

American Honda Motor Co., Inc.  
Customer Relations Department  
P.O. Box 420  
Gardena, California 90247  
Telephone: (213) 604-2524

**SOUTHWEST REGIONAL OFFICE**  
American Honda Motor Co., Inc.  
Customer Relations Department  
P.O. Box 5408  
Irving, Texas 75062  
Telephone: (214) 258-8883

### **SOUTHEAST REGIONAL OFFICE** (includes Puerto Rico)

American Honda Motor Co., Inc.  
Customer Relations Department  
6684 Jimmy Carter Boulevard  
Norcross, Georgia 30071  
Telephone: (404) 448-1982



**HONDA**

HONDA MOTOR CO., LTD. TOKYO, JAPAN

31736000  
00X31-736-0000

英 ¥35008406  
PRINTED IN JAPAN