

**HONDA**

**Power**

**Equipment**

# Owner's Manual

## GENERATOR

### EU3000i *Handi*

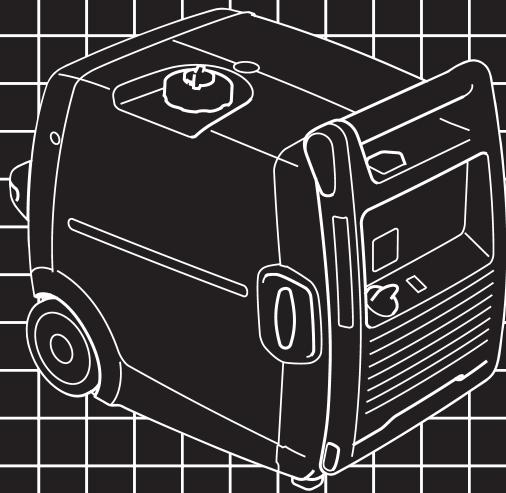



## **WARNING:**



The engine exhaust from this product contains chemicals known to the State of California to cause cancer, birth defects or other reproductive harm.

### **California Proposition 65**

This product contains or emits chemicals known to the state of California to cause cancer, birth defects or other reproductive harm

## **⚠ WARNING**

Exhaust contains poisonous carbon monoxide gas that can build up to dangerous levels in closed areas.

Breathing carbon monoxide can cause unconsciousness or death.

Never run the generator in a closed, or even partly closed area where people may be present.

Keep this owner's manual handy, so that you can refer to it any time. This owner's manual is considered a permanent part of the generator and should remain with the generator if resold.

The information and specifications included in this publication were in effect at the time of approval for printing. Honda Motor Co., Ltd. reserves the right, however, to discontinue or change specifications or design at any time without notice and without incurring any obligation whatsoever.

# INTRODUCTION

Congratulations on your selection of a Honda generator. We are certain you will be pleased with your purchase of one of the finest generators on the market.

We want to help you get the best results from your new generator and to operate it safely. This manual contains the information on how to do that; please read it carefully.

As you read this manual, you will find information preceded by a **NOTICE** symbol. That information is intended to help you avoid damage to your generator, other property, or the environment.

We suggest you read the *Distributor's Limited Warranty* (see page 76) to fully understand its coverage and your responsibilities of ownership.

When your generator needs scheduled maintenance, keep in mind that your Honda servicing dealer is specially trained in servicing Honda generators and is supported by the parts and service divisions of American Honda. Your Honda servicing dealer is dedicated to your satisfaction and will be pleased to answer your questions and concerns.

Best Wishes,  
Honda Motor Co., Ltd.

---

## A FEW WORDS ABOUT SAFETY

Your safety and the safety of others are very important. And using this generator safely is an important responsibility.

To help you make informed decisions about safety, we have provided operating procedures and other information on labels and in this manual. This information alerts you to potential hazards that could hurt you or others.

Of course, it is not practical or possible to warn you about all the hazards associated with operating or maintaining a generator. You must use your own good judgement.

You will find important safety information in a variety of forms, including:

- **Safety Labels** — on the generator.
- **Safety Messages** — preceded by a safety alert symbol  and one of three signal words, DANGER, WARNING, or CAUTION.

These signal words mean:

 **DANGER**

You **WILL** be **KILLED** or **SERIOUSLY HURT** if you don't follow instructions.

 **WARNING**

You **CAN** be **KILLED** or **SERIOUSLY HURT** if you don't follow instructions.

 **CAUTION**

You **CAN** be **HURT** if you don't follow instructions.

- **Safety Headings** — such as *IMPORTANT SAFETY INFORMATION*.
- **Safety Section** — such as *GENERATOR SAFETY*.
- **Instructions** — how to use this generator correctly and safely.

This entire book is filled with important safety information — please read it carefully.

# CONTENTS

<b>GENERATOR SAFETY</b> .....	<b>6</b>
<b>IMPORTANT SAFETY INFORMATION</b> .....	<b>6</b>
Operator Responsibility .....	6
Carbon Monoxide Hazards.....	6
Electric Shock Hazards .....	7
Fire and Burn Hazards .....	7
Refuel With Care .....	8
<b>SAFETY LABEL LOCATIONS</b> .....	<b>9</b>
<b>CONTROLS &amp; FEATURES</b> .....	<b>10</b>
<b>COMPONENT &amp; CONTROL LOCATIONS</b> .....	<b>10</b>
<b>CONTROLS</b> .....	<b>12</b>
Engine Switch .....	12
Starter Grip.....	12
Fuel Filler Cap Vent Lever.....	13
Eco-Throttle Switch .....	13
Parallel Operation Outlets .....	14
AC Circuit Protectors .....	14
DC Receptacle .....	15
DC Circuit Protector .....	15
Folding Handle .....	16
<b>FEATURES</b> .....	<b>17</b>
Ground Terminal .....	17
Output Indicator .....	18
Overload Indicator .....	19
Oil Alert Indicator.....	19
<b>BEFORE OPERATION</b> .....	<b>20</b>
<b>ARE YOU READY TO GET STARTED?</b> .....	<b>20</b>
Knowledge.....	20
<b>IS YOUR GENERATOR READY TO GO?</b> .....	<b>20</b>
Check the Engine .....	21

# CONTENTS

---

<b>OPERATION .....</b>	<b>22</b>
SAFE OPERATING PRECAUTIONS.....	22
STARTING THE ENGINE .....	23
STOPPING THE ENGINE .....	26
AC OPERATION.....	28
AC Applications.....	29
AC PARALLEL OPERATION.....	30
AC Parallel Operation Applications .....	32
DC OPERATION.....	34
ECO-THROTTLE SYSTEM .....	37
STANDBY POWER .....	38
Connections to a Building's Electrical System .....	38
System Ground .....	38
Special Requirements.....	39
<b>SERVICING YOUR GENERATOR.....</b>	<b>40</b>
THE IMPORTANCE OF MAINTENANCE.....	40
MAINTENANCE SAFETY.....	41
Safety Precautions .....	41
MAINTENANCE SCHEDULE .....	42
REFUELING .....	43
FUEL RECOMMENDATIONS.....	45
ENGINE OIL LEVEL CHECK .....	46
ENGINE OIL CHANGE.....	48
ENGINE OIL RECOMMENDATIONS .....	50
AIR CLEANER SERVICE .....	51
AIR FILTER CLEANING .....	53
SPARK PLUG SERVICE.....	54
SPARK ARRESTER SERVICE.....	56
<b>STORAGE.....</b>	<b>58</b>
STORAGE PREPARATION.....	58
Cleaning.....	58
Fuel.....	58
Engine Oil .....	61
Engine Cylinder .....	61
STORAGE PRECAUTIONS .....	62
REMOVAL FROM STORAGE.....	62

<b>TRANSPORTING</b> .....	<b>63</b>
<b>TAKING CARE OF UNEXPECTED PROBLEMS</b> .....	<b>64</b>
ENGINE WILL NOT START.....	64
ENGINE LACKS POWER .....	65
NO POWER AT THE AC RECEPTACLES .....	66
NO POWER AT THE DC RECEPTACLE .....	66
<b>TECHNICAL INFORMATION</b> .....	<b>67</b>
Serial Number Location .....	67
Carburetor Modification for High Altitude Operation.....	68
Emission Control System Information.....	69
Air Index .....	71
Specifications .....	72
Wiring Diagram .....	73
<b>CONSUMER INFORMATION</b> .....	<b>74</b>
Dealer Locator Information .....	74
Honda Publications .....	74
Customer Service Information.....	75
Distributor's Limited Warranty .....	76
Emission Control System Warranty.....	81
<b>INITIAL USE INSTRUCTIONS</b> .....	<b>86</b>
ENGINE OIL .....	86
FUEL .....	87
BEFORE OPERATION .....	89
REGISTRATION.....	89
<b>INDEX</b> .....	<b>90</b>
<b>QUICK REFERENCE INFORMATION</b> .....	<b>Inside back cover</b>

# GENERATOR SAFETY

## IMPORTANT SAFETY INFORMATION

Honda generators are designed for use with electrical equipment that has suitable power requirements. Other uses can result in injury to the operator or damage to the generator and other property.

Most injuries or property damage can be prevented if you follow all the instructions in this manual and on the generator. The most common hazards are discussed below, along with the best way to protect yourself and others.

### Operator Responsibility

- Know how to stop the generator quickly in case of emergency.
- Understand the use of all generator controls, output receptacles, and connections.
- Be sure that anyone who operates the generator receives proper instruction. Do not let children operate the generator without parental supervision.

### Carbon Monoxide Hazards

A generator's exhaust contains toxic carbon monoxide, which you cannot see or smell. Breathing carbon monoxide can **KILL YOU IN MINUTES**. To avoid carbon monoxide poisoning, follow these instructions when operating a generator:

- Only run a generator **OUTSIDE**, far away from windows, doors, and vents.
- Never operate a generator inside a house, garage, basement, crawl space, or any enclosed or partially enclosed space.
- Never operate a generator near open doors or windows.
- Get fresh air and seek medical attention immediately if you suspect you have inhaled carbon monoxide.

Early symptoms of carbon monoxide exposure include headache, fatigue, shortness of breath, nausea, and dizziness. Continued exposure to carbon monoxide can cause loss of muscular coordination, loss of consciousness, and then death.



To alert you to potentially dangerous levels of carbon monoxide coming from a generator operating outside or from other sources, install battery operated carbon monoxide alarms or plug-in carbon monoxide alarms with battery back-up on every level of the home and outside sleeping areas, according to the manufacturer's instructions.

## **Electric Shock Hazards**

- The generator produces enough electric power to cause a serious shock or electrocution if misused.
- Using a generator or electrical appliance in wet conditions, such as rain or snow, or near a pool or sprinkler system, or when your hands are wet, could result in electrocution. Keep the generator dry.
- If the generator is stored outdoors, unprotected from the weather, check all of the electrical components on the control panel before each use. Moisture or ice can cause a malfunction or short circuit in electrical components that could result in electrocution.
- Do not connect to a building's electrical system unless an isolation switch has been installed by a qualified electrician.
- Use only a Honda approved parallel operation cable kit (optional equipment) when connecting two EU3000i generators for parallel operation.
- Never connect different generator models.

## **Fire and Burn Hazards**

- The exhaust system gets hot enough to ignite some materials.
  - Keep the generator at least 3 feet (1 meter) away from buildings and other equipment during operation.
  - Do not enclose the generator in any structure.
  - Keep flammable materials away from the generator.
- The muffler becomes very hot during operation and remains hot for a while after stopping the engine. Be careful not to touch the muffler while it is hot. Let the engine cool before storing the generator indoors.

# GENERATOR SAFETY

---

## Refuel With Care

Gasoline is extremely flammable, and gasoline vapor can explode.

Do not refuel during operation.

Allow the engine to cool if it has been in operation.

Refuel only outdoors in a well-ventilated area and on a level surface.

Never smoke near gasoline, and keep other flames and sparks away.







Do not overfill the fuel tank.

Make sure that any spilled fuel has been wiped up and cleaned before starting the engine.

Always store gasoline in an approved container.

## SAFETY LABEL LOCATIONS

These labels warn you of potential hazards that can cause serious injury. Read them carefully. If a label comes off or becomes hard to read, contact your Honda servicing dealer for a replacement.

<b>⚠ DANGER</b> Using a generator indoors CAN KILL YOU IN MINUTES. Generator exhaust contains carbon monoxide. This is a poison you cannot see or smell.	
 <b>NEVER</b> use inside a home or garage, <b>EVEN IF</b> doors and windows are open.	 Only use <b>OUTSIDE</b> and far away from windows, doors, and vents.
<b>⚠ WARNING</b> Gasoline is highly flammable and explosive. You could be burned or seriously injured if the gasoline is ignited. <ul style="list-style-type: none"><li>■ Before refueling, stop the engine and keep heat, sparks, and flame away.</li><li>■ Handle fuel only outdoors.</li><li>■ Do not fill the fuel tank above the upper limit line.</li><li>■ Wipe up spills immediately.</li><li>■ After operation, turn the engine switch and fuel tank cap lever to the "OFF" position prevent fuel leakage.</li></ul>	
	Exhaust contains poisonous carbon monoxide gas that can build up to dangerous levels in closed areas. Breathing carbon monoxide can cause unconsciousness or death. <ul style="list-style-type: none"><li>■ Never run the generator in a closed, or even partly closed area where people may be present.</li></ul>
	Improper connections to a building can allow electrical current to backfeed into utility lines, creating an electrocution hazard. <ul style="list-style-type: none"><li>■ Connections to a building must isolate generator power from utility power and comply with all applicable laws and electrical codes.</li></ul>
	The generator is a potential source of electrical shock if not kept dry. <ul style="list-style-type: none"><li>■ Do not expose the generator to moisture, rain or snow.</li><li>■ Do not operate the generator with wet hands.</li></ul>
	Read owner's manual carefully before operation.

<b>⚠ WARNING</b> Operation of This Equipment May Create Sparks That Can Start Fires Around Dry Vegetation. A Spark Arrestor May be Required. The Operator Should Contact Local Fire Agencies For Laws or Regulations Relating to Fire Prevention Requirements. <small>Per California Public Resources Code 4442.6</small>	
	<b>⚠ CAUTION</b> A hot exhaust system can cause serious burns. <ul style="list-style-type: none"><li>■ Avoid contact if the engine has been running.</li></ul>

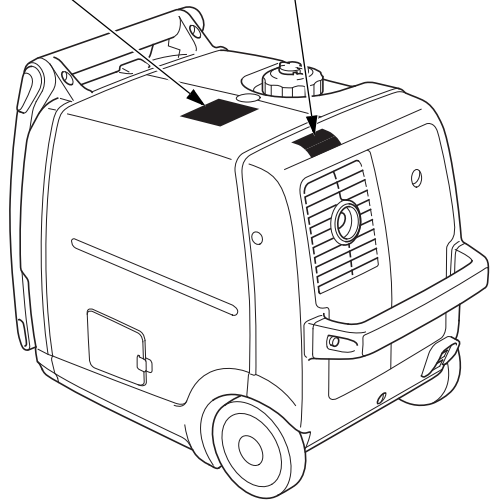

# CONTROLS & FEATURES

## COMPONENT & CONTROL LOCATIONS

Use the illustrations on these pages to locate and identify the most frequently used controls.

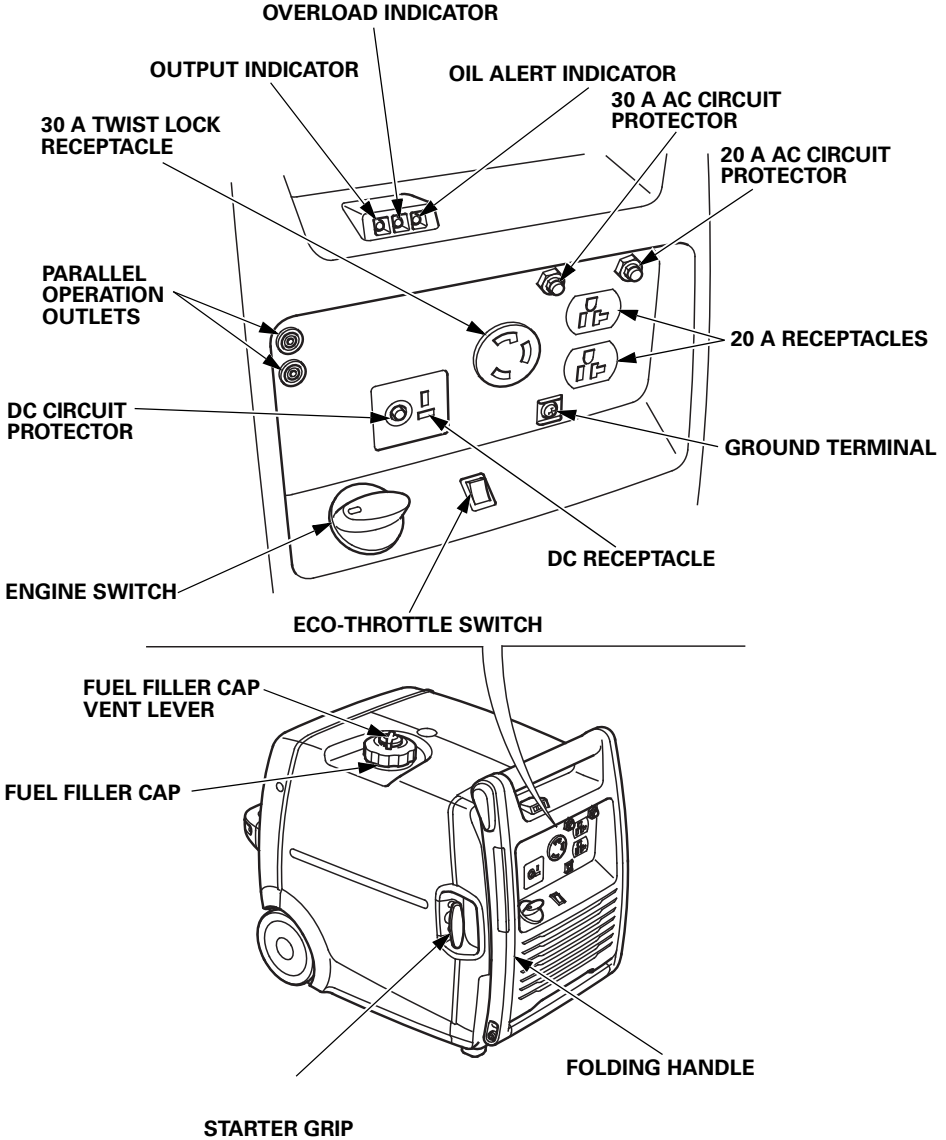

# CONTROLS & FEATURES

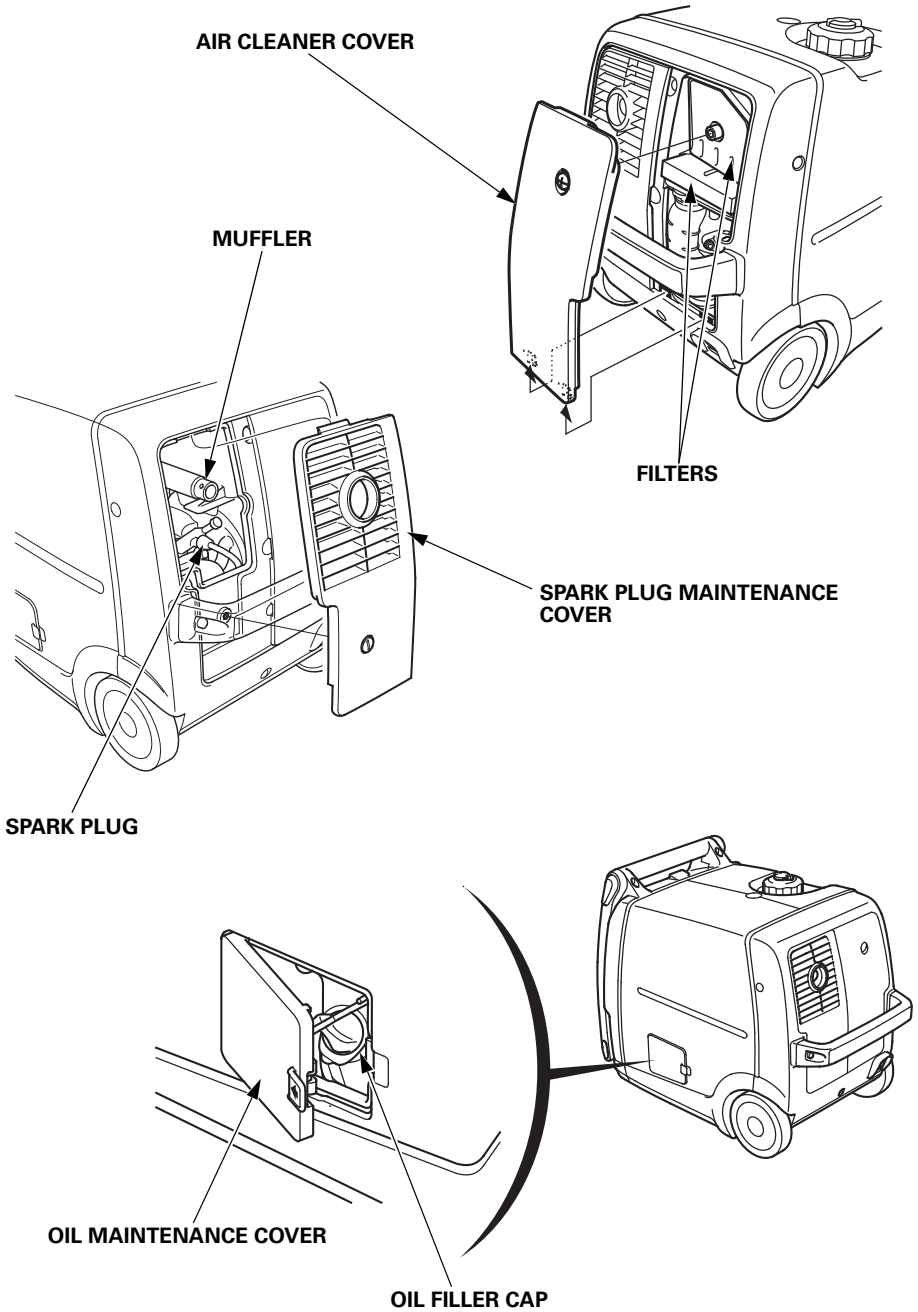

# CONTROLS & FEATURES

## CONTROLS

### Engine Switch

The engine switch controls the ignition system, fuel valve and choke valve.

**OFF** – Stops the engine and closes the fuel valve.

**ON** – Running position; opens the fuel valve and allows the engine to be started.

**CHOKE** – Closes choke valve. The choke is used to provide proper starting mixture when the engine is cold.

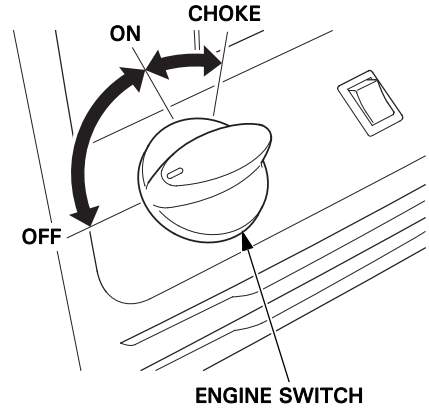

### Starter Grip

Pulling the starter grip operates the recoil starter to crank the engine.

#### NOTICE

*Do not allow the starter grip to snap back against the generator. Return it gently to prevent damage to the starter.*

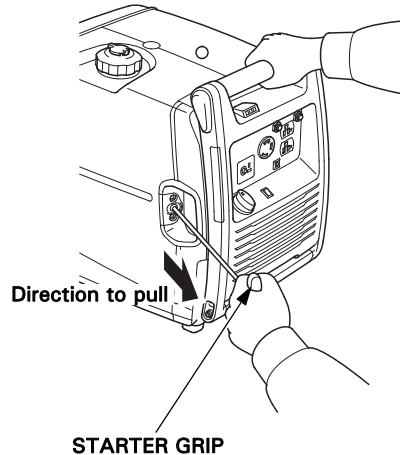

## Fuel Filler Cap Vent Lever

The fuel filler cap is provided with a vent lever to seal the fuel tank.

The vent lever must be in the ON position for the engine to run.

When the engine is not in use, leave the vent lever in the OFF position to reduce the possibility of fuel leakage. Allow the engine to cool well before turning the vent lever to the OFF position.

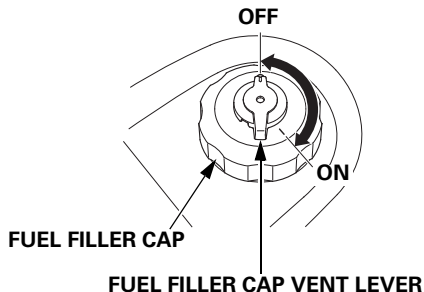

## Eco-Throttle™ Switch

The Eco-Throttle™ system automatically reduces engine speed when loads are turned off or disconnected. When appliances are turned on or reconnected, the engine returns to the proper speed to power the electrical load.

If high electrical loads are connected simultaneously, turn the Eco-Throttle switch to the OFF position to reduce voltage changes. When using the DC output, turn the Eco-Throttle switch to the OFF position.

**ON:** Recommended to minimize fuel consumption and further reduce noise levels when less than a full load is applied to the generator.

**OFF:** The Eco-Throttle system does not operate.

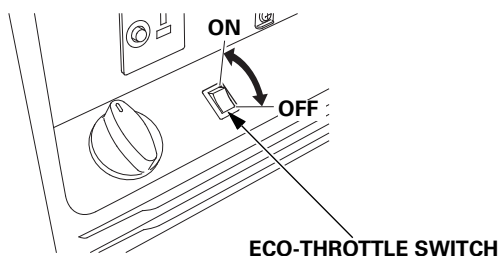

# CONTROLS & FEATURES

## Parallel Operation Outlets

These outlets are used for connecting two EU3000i generators for parallel operation (see page 30). A Honda approved parallel operation cable kit (optional equipment) is required for parallel operation. This kit can be purchased from an authorized Honda generator dealer.

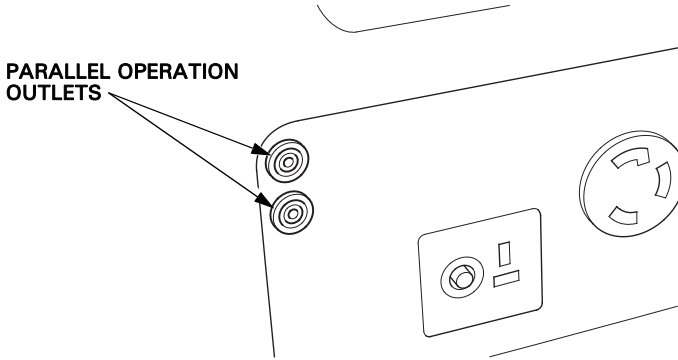

## AC Circuit Protectors

The AC circuit protectors will automatically switch to OFF if there is a short circuit or a significant overload of the generator at the 120 V 20 A receptacle or 120 V 30 A twist lock receptacle. If an AC circuit protector switches OFF automatically, check that the appliance is working properly and does not exceed the rated load capacity of the circuit before resetting the AC circuit protector ON.

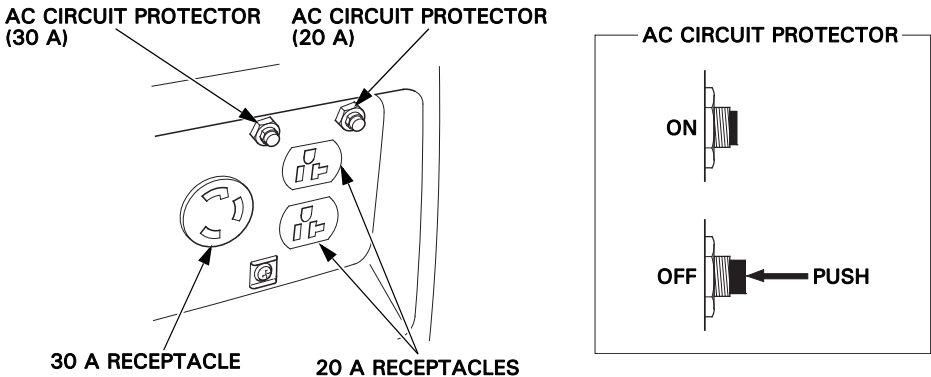



## DC Receptacle

The DC receptacle should **ONLY** be used for charging 12-volt automotive type batteries. The DC charging output is not regulated.

## DC Circuit Protector

The DC circuit protector automatically shuts off the DC battery charging circuit when the DC charging circuit is overloaded, when there is a problem with the battery, or when the connections between the battery and the generator are improper. However, the DC circuit protector does not prevent overcharging.

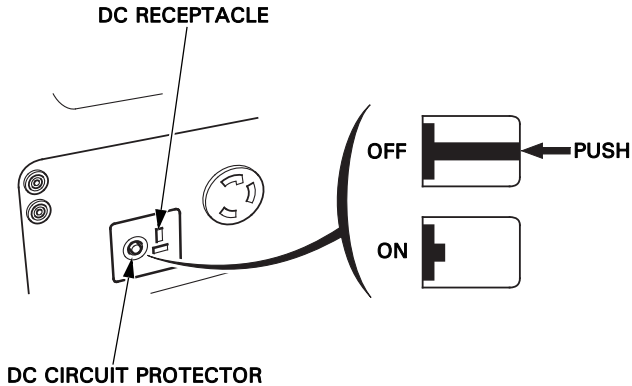

# CONTROLS & FEATURES

## Folding Handle

The foldable handle is intended for ease of transportation and should be folded when the generator is stationary. Do not rest objects on the handle when in the transport position.



### To Extend The Handle

Lift the handle upward with both hands.

### To Fold The Handle

Lower the handle with both hands until it clicks into place.

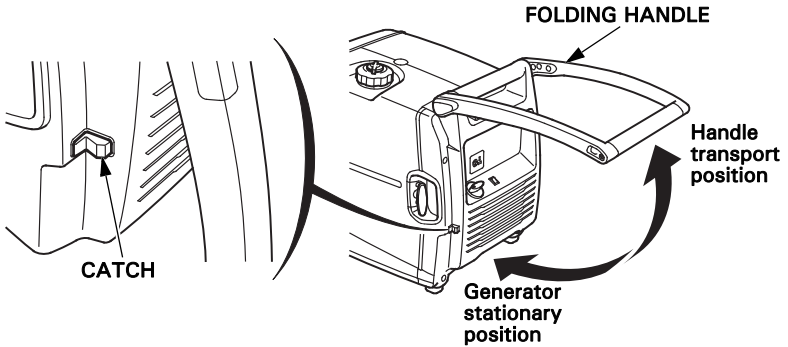

### NOTICE

*To avoid overturning or damage:*

- Do not use the folding handle when moving the generator over rough surfaces.
- When two people carry the generator, close the folding handle.
- Do not place any objects on the generator.

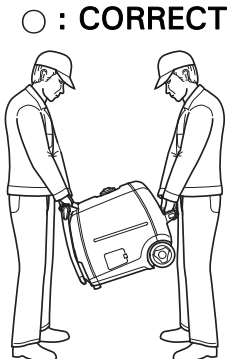

## FEATURES

### Ground Terminal

The generator ground terminal is connected to the frame of the generator, the metal non-current-carrying parts of the generator, and the ground terminals of each receptacle.

Before using the ground terminal, consult a qualified electrician, electrical inspector, or local agency having jurisdiction for local codes or ordinances that apply to the intended use of the generator.

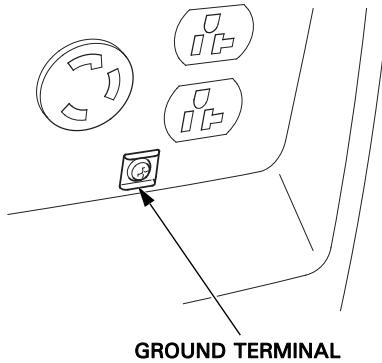

# CONTROLS & FEATURES

---

## Output Indicator

The output indicator (green) is illuminated when the generator is operating normally. It indicates that the generator is producing electrical power at the receptacles.

In addition, the output indicator has a simplified hour meter function. When you start the engine, the indicator blinks according to the generator's cumulative operating hours as follows:

- No blinks: 0–100 hours
- 1 blink: 100–200 hours
- 2 blinks: 200–300 hours
- 3 blinks: 300–400 hours
- 4 blinks: 400–500 hours
- 5 blinks: 500 or more hours

**OUTPUT INDICATOR  
(GREEN)**

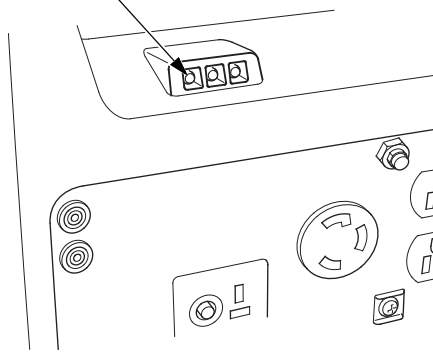

## Overload Indicator

If the generator is overloaded (in excess of 3.0 kVA), or if there is a short circuit in a connected appliance, the overload indicator (red) will come on. If the overload indicator (red) stays on continuously for more than 4 seconds, current to the connected appliance(s) will shut off, and the output indicator (green) will go off. However, the engine will continue to run.

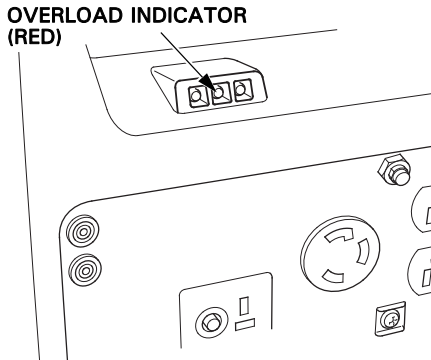

## Oil Alert® Indicator

The Oil Alert® system is designed to prevent engine damage caused by an insufficient amount of oil in the crankcase. Before the oil level in the crankcase can fall below a safe limit, the Oil Alert indicator (red) comes on and the Oil Alert system automatically will stop the engine (the engine switch will remain in the ON position).

If the engine stops or the Oil Alert indicator (red) comes on when you pull the starter grip, check the engine oil level (see page 46) before troubleshooting in other areas.

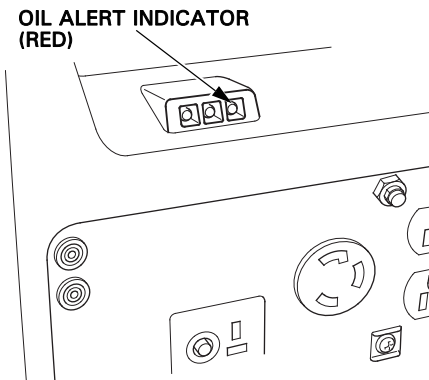

# BEFORE OPERATION

## ARE YOU READY TO GET STARTED?

Your safety is your responsibility. A little time spent in preparation will significantly reduce your risk of injury.

### Knowledge

Read and understand this manual. Know what the controls do and how to operate them.

Familiarize yourself with the generator and its operation before you begin using it. Know how to quickly shut off the generator in case of an emergency.

If the generator is being used to power appliances, be sure that they do not exceed the generator's load rating (see pages 29 and 33).

## IS YOUR GENERATOR READY TO GO?

For your safety, to ensure compliance with environmental regulations, and to maximize the service life of your equipment, it is very important to take a few moments before you operate the generator to check its condition. Be sure to take care of any problem you find, or have your servicing dealer correct it, before you operate the generator.

### **WARNING**

Failure to properly maintain this generator, or failing to correct a problem before operation, could result in a significant malfunction.

Some malfunctions can seriously hurt or kill you.

Always perform a pre-operation inspection before each operation and correct any problems.

To prevent a possible fire, keep the generator at least 3 feet (1 meter) away from building walls and other equipment during operation. Do not place flammable objects close to the engine.

Before beginning your pre-operation checks, be sure the generator is on a level surface and the engine switch is in the OFF position.

## **Check the Engine**

- Before each use, look around and underneath the engine for signs of oil or gasoline leaks.
- Check the oil level (see page 46). A low oil level will cause the Oil Alert system to shut down the engine.
- Check the air filter (see page 51). A dirty air filter will restrict air flow to the carburetor, reducing engine and generator performance.
- Check the fuel level (see page 43). Starting with a full tank will help to eliminate or reduce operating interruptions for refueling.

# OPERATION

## SAFE OPERATING PRECAUTIONS

Before operating the generator for the first time, review chapters *GENERATOR SAFETY* (see page 6) and *BEFORE OPERATION* (see page 20).

For your safety, do not operate the generator in an enclosed area such as a garage. Your generator's exhaust contains poisonous carbon monoxide gas that can collect rapidly in an enclosed area and cause illness or death.

### **WARNING**

Exhaust contains poisonous carbon monoxide gas that can build up to dangerous levels in closed areas.

Breathing carbon monoxide can cause unconsciousness or death.

Never run this product's engine in a closed, or even partly closed area where people may be present.

Before connecting an AC appliance or power cord to the generator:

- Use grounded 3-prong extension cords, tools, and appliances, or double-insulated tools and appliances.
- Inspect cords and plugs, and replace if damaged.
- Make sure that the appliance is in good working order. Faulty appliances or power cords can create a potential for electric shock.
- Make sure the electrical rating of the tool or appliance does not exceed the rated power of the generator or the receptacle being used.
- Operate the generator at least 3 feet (1 meter) away from buildings and other equipment.
- Do not operate the generator in an enclosed structure.
- Do not place flammable objects close to the engine or locate the generator near flammable materials.



## STARTING THE ENGINE

To prevent a possible fire, keep the generator at least 3 feet (1 meter) away from building walls and other equipment during operation. Do not place flammable objects close to the engine.

### NOTICE

*Operating this generator less than 3 feet (1 meter) from a building or other obstruction can cause overheating and damage the generator. For proper cooling, allow at least 3 feet (1 meter) of empty space above and around the generator.*

Refer to *SAFE OPERATING PRECAUTIONS* on page 22 and perform the *IS YOUR GENERATOR READY TO GO* checks (see page 20). Refer to *AC OPERATION* (see page 28) or *DC OPERATION* (see page 34) for connecting loads to the generator.

1. Make sure that all appliances are disconnected from the AC receptacle.
2. Turn the fuel filler cap vent lever to the ON position.

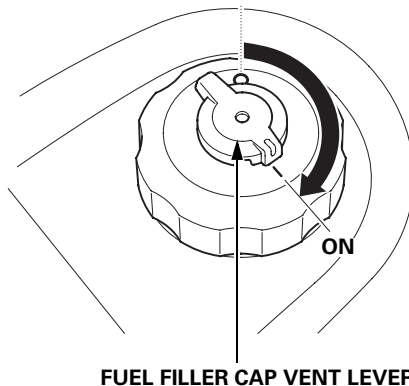

# OPERATION

3. Make sure the Eco-Throttle switch is in the OFF position.

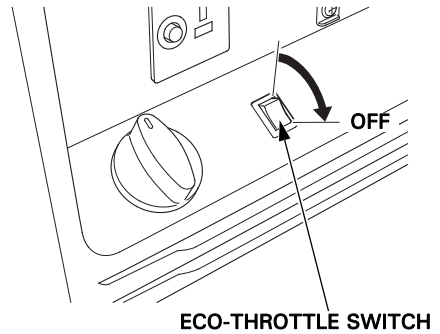

4. Turn the engine switch to the ON position.  
To start a cold engine, turn the engine switch to the CHOKE position.  
To restart a warm engine, leave the engine switch in the ON position.

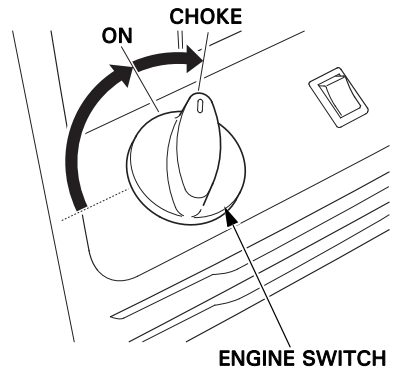

5. Pull the starter grip lightly until you feel resistance; then pull briskly in the direction of the arrow as shown.

**NOTICE**

*Do not allow the starter grip to snap back against the generator. Return it gently to prevent damage to the starter.*

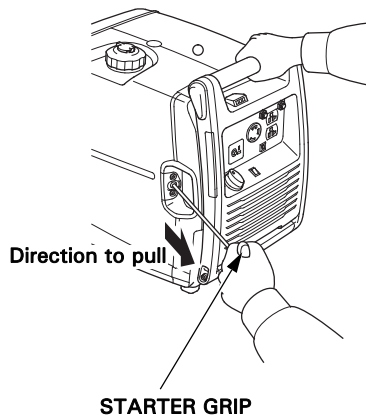

6. If the engine switch was turned to the CHOKE position to start the engine, turn it to the ON position as the engine warms up.

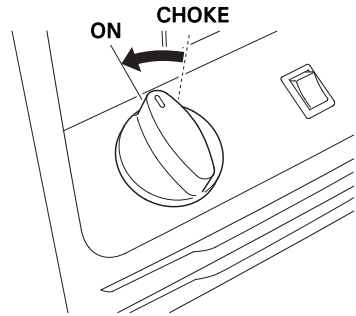

7. If you wish to use the Eco-Throttle system, turn the Eco-Throttle switch to the ON position after the engine has warmed up for 2 or 3 minutes.

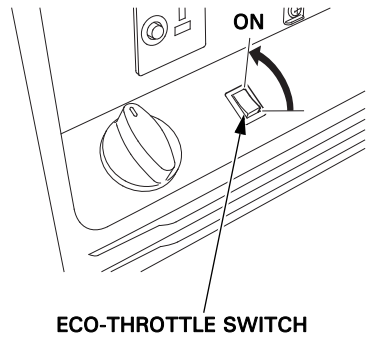

# OPERATION

---

## STOPPING THE ENGINE

To stop the engine in an emergency, simply turn the engine switch to the OFF position. Under normal conditions, use the following procedure.

1. Turn off or disconnect all appliances that are connected to the generator.
2. Turn the engine switch to the OFF position.

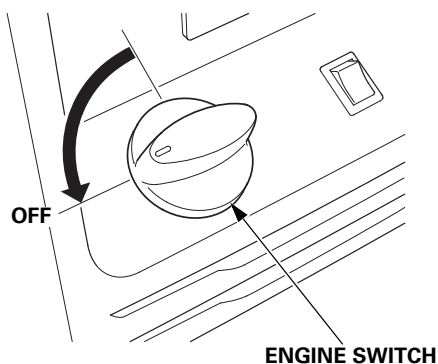

3. Allow the engine to cool, and then turn the fuel filler cap vent lever to the OFF position.

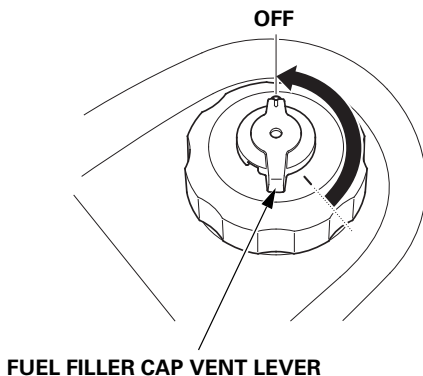

4. If two generators were connected for parallel operation, disconnect the parallel operation cable after stopping the engines if you do not wish to resume parallel operation.

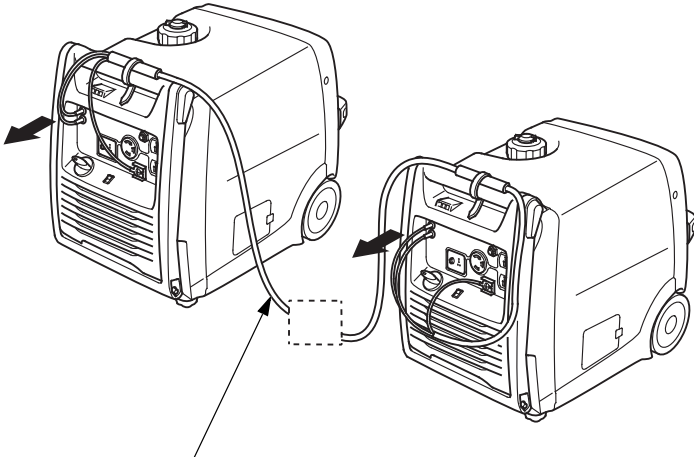

**PARALLEL OPERATION CABLE**  
(optional equipment)

# OPERATION

---

## AC OPERATION

Before connecting an appliance to the generator, make sure that the appliance is in good working order and that its electrical rating does not exceed that of the receptacle.

Most motorized appliances require more than their electrical rating for startup. When an electric motor is started, the overload indicator (red) may come on. This is normal if the overload indicator (red) goes off within 9 seconds. If the overload indicator (red) stays on, consult your generator dealer.

1. Start the engine (see page 23) and make sure the output indicator (green) comes on.

OUTPUT INDICATOR  
(GREEN)

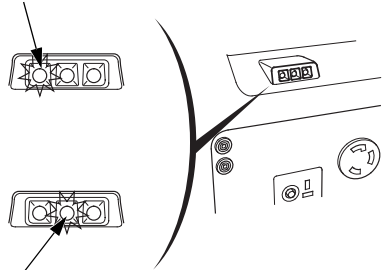

2. Plug an appliance into the appropriate receptacle.

OVERLOAD INDICATOR  
(RED)

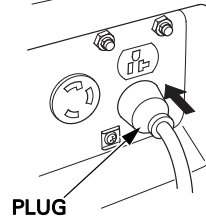

3. Turn on the appliance.

If the generator is overloaded (see page 29), or if there is a short circuit in a connected appliance, the overload indicator (red) will come on. If the overload indicator (red) stays on continuously for more than 4 seconds, current to the connected appliance(s) will shut off, and the output indicator (green) will go off. Stop the engine and investigate the problem.

Determine if the cause is a short circuit in a connected appliance or an overload. Correct the problem and restart the generator.

## AC Applications

Before connecting an appliance or power cord to the generator:

- Make sure that it is in good working order. A faulty appliance or power cord can create a potential for electrical shock.
- If an appliance begins to operate abnormally, becomes sluggish, or stops suddenly, turn it off immediately. Disconnect the appliance, and determine whether the problem is the appliance or the rated load capacity of the generator has been exceeded.

Most appliance motors require more than their rated wattage for startup.

Make sure the electrical rating of the tool or appliance does not exceed the maximum power rating of the generator.

Maximum power is:

3.0 kVA

For continuous operation, do not exceed the rated power.

Rated power is:

2.6 kVA

In either case, the total power requirements (VA) of all appliances connected must be considered. Appliance and power tool manufacturers usually list rating information near the model number or serial number.

### NOTICE

*Substantial overloading will open the circuit protector. Slightly overloading the generator may not switch the circuit protector OFF, but will shorten the service life of the generator.*

# OPERATION

---

## AC PARALLEL OPERATION

Before connecting an appliance to either generator, make sure that the appliance is in good working order and that its electrical rating does not exceed that of the receptacle.

Most motorized appliances require more than their electrical rating for startup. When an electric motor is started, the overload indicator (red) may come on. This is normal if the overload indicator (red) goes off within 9 seconds. If the overload indicator (red) stays on, consult your generator dealer.

During parallel operation, the Eco-Throttle switch should be in the same position on both generators.

1. Connect the parallel operation cable kit between the two EU3000i generators following the instructions supplied with the kit.

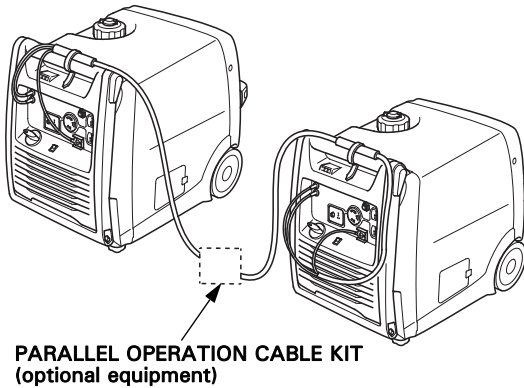

2. Start the engines (see page 23) and make sure the output indicator (green) on each generator comes on.

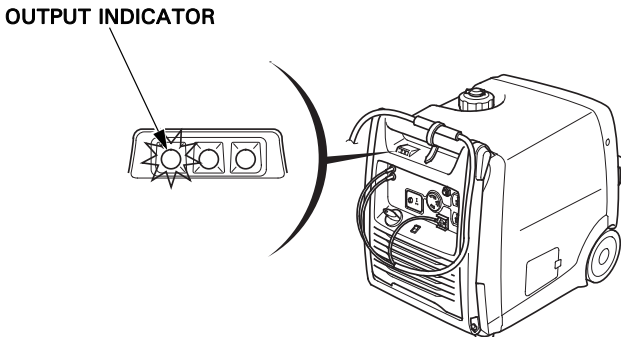



3. Plug in the appliance following the instruction provided with the parallel operation cable kit.

4. Turn on the appliance.

If the generators are overloaded (see page 33), or if there is a short circuit in a connected appliance, the overload indicator (red) will come on. If the overload indicator (red) stays on continuously for more than 4 seconds, current to the connected appliance(s) will shut off, and the output indicator (green) will go off. Stop both engines and investigate the problem.

Determine if the cause is a short circuit in a connected appliance or an overload. Correct the problem and restart the generator.

**OVERLOAD INDICATOR**

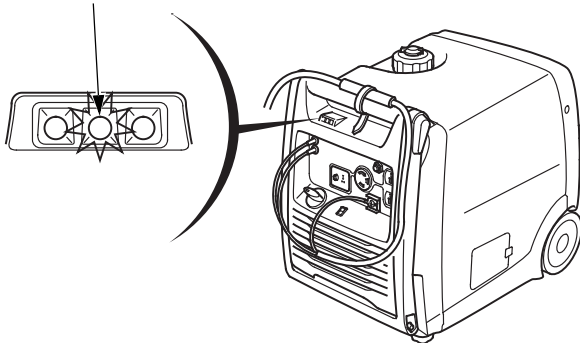

# OPERATION

---

## AC Parallel Operation Applications

Follow the instructions included with the parallel operation cable kit.

Before connecting an appliance or power cord to the generator:

- Make sure that it is in good working order. A faulty appliance or power cord can create a potential for electrical shock.
- If an appliance begins to operate abnormally, becomes sluggish, or stops suddenly, turn it off immediately. Disconnect the appliance, and determine whether the problem is the appliance or the rated load capacity of the generator has been exceeded.
- Never connect different generator models.
- Use only a Honda approved parallel operation kit (optional equipment) when connecting two EU3000i Handi generators for parallel operation.
- Never connect or remove the parallel operation cable when the generator is running.
- For single generator operation, the parallel operation cable must be removed.

Most appliance motors require more than their rated wattage for startup.

Make sure the electrical rating of the tool or appliance does not exceed the maximum power rating of the generator.

Maximum power in parallel operation is:

6.0 kVA

For continuous operation, do not exceed the rated power.

Rated power in parallel operation is:

5.2 kVA

In either case, the total power requirements (VA) of all appliances connected must be considered. Appliance and power tool manufacturers usually list rating information near the model number or serial number.

**NOTICE**

*Substantial overloading that continuously lights the overload indicator (red) may damage the generator. Marginal overloading that temporarily lights the overload indicator (red) may shorten the service life of the generator.*

# OPERATION

---

## DC OPERATION

The DC receptacle should **ONLY** be used for charging 12-volt automotive type batteries. The DC charging output is not regulated.

The DC receptacle can be used while the AC power is in use. When using the AC power together with DC power, do not exceed 20.8 ampere AC load.

When using the DC output, turn the Eco-Throttle switch to the OFF position.

### Connecting the battery charging cable (optional equipment):

1. Before connecting the battery charging cable to a battery that is installed in a vehicle, disconnect the vehicle battery ground cable from the negative (-) battery terminal.

#### **WARNING**

The battery gives off explosive hydrogen gas during normal operation.

A spark or flame can cause the battery to explode with enough force to kill or seriously hurt you.

Wear protective clothing and a face shield, or have a skilled mechanic perform the battery maintenance.

**WARNING:** Battery posts, terminals, and related accessories contain lead and lead components. **Wash hands after handling.**

2. Plug the battery charging cable into the DC receptacle of the generator.

3. Connect the red lead of the battery charging cable to the positive (+) battery terminal and the black lead to the negative (-) battery terminal.

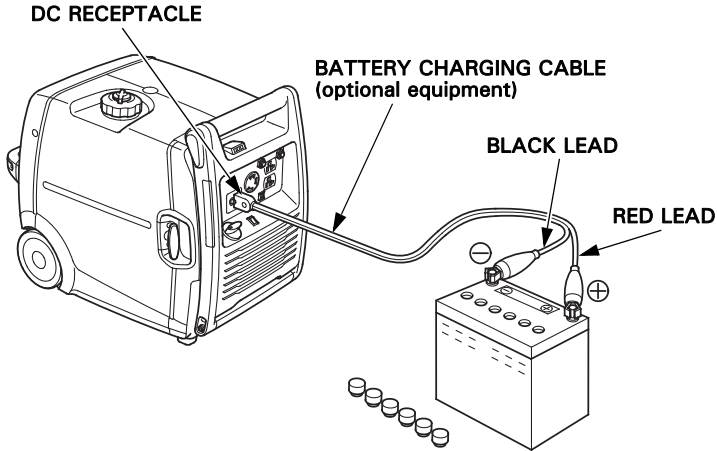

4. Start the generator (see page 23).

## NOTICE

*Do not start the vehicle while the battery charging cable is connected and the generator is running. The vehicle or the generator may be damaged.*

An overloaded DC circuit, excessive current draw by the battery, or a wiring problem will trip the DC circuit protector (PUSH button extends out). If this happens, wait a few minutes before pushing in the circuit protector to resume operation. If the DC circuit protector continues to go OFF, discontinue charging and see your authorized Honda generator dealer. The circuit protector does not prevent overcharging the battery.

## DC CIRCUIT PROTECTOR

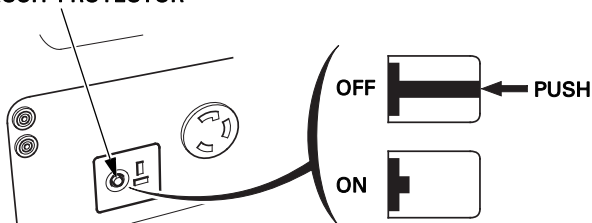

# OPERATION

---

## Disconnecting the battery charging cable:

1. Stop the engine.
2. Disconnect the black lead of the battery charging cable from the negative (-) battery terminal.
3. Disconnect the red lead of the battery charging cable from the positive (+) battery terminal.
4. Disconnect the battery charging cable from the DC receptacle of the generator.
5. Connect the vehicle battery ground cable to the negative (-) battery terminal.

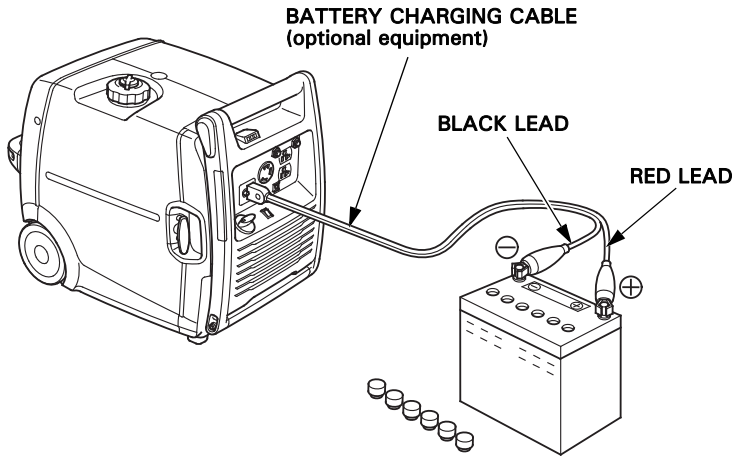

## ECO-THROTTLE™ SYSTEM

With the switch in the ON position, engine speed is automatically lowered when loads are reduced, turned off, or disconnected. When appliances are turned on or reconnected, the engine returns to the proper speed to power the electrical load. In the OFF position, the Eco-Throttle™ system does not operate.

Appliances with large start-up power demands may not allow the engine to reach normal operating rpm when they are connected to the generator. Turn the Eco-Throttle switch to the OFF position and connect the appliance to the generator. If the engine still will not reach normal operating speed, check that the appliance does not exceed the rated load capacity of the generator.

If high electrical loads are connected simultaneously, turn the Eco-Throttle switch to the OFF position to reduce voltage changes.

The Eco-Throttle system is not effective for use with appliances or tools that require only momentary power. If the tool or appliance will be turned ON and OFF quickly, the Eco-Throttle switch should be in the OFF position.

When using the DC output, turn the Eco-Throttle switch to the OFF position.

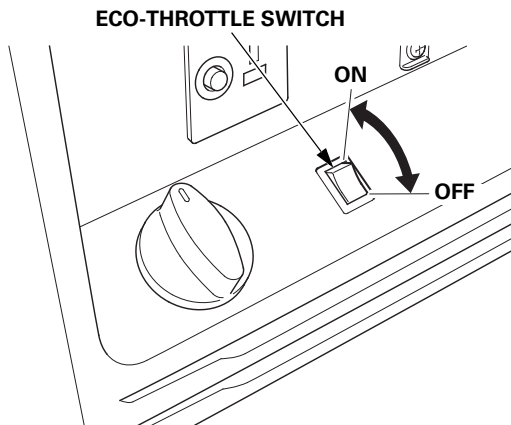

# OPERATION

---

## STANDBY POWER

### Connections to a Building's Electrical System

Connections for standby power to a building's electrical system must be made by a qualified electrician. The connection must isolate the generator power from utility power, and must comply with all applicable laws and electrical codes.

#### **⚠ WARNING**

Improper connections to a building's electrical system can allow current from the generator to backfeed into the utility lines.

Such backfeed may electrocute utility company workers or others who contact the lines during a power outage, and the generator may explode, burn, or cause fires when utility power is restored.

Consult the utility company or a qualified electrician prior to making any power connections.

In some areas, generators are required by law to be registered with local utility companies. Check local regulations for proper registration and use procedures.

### System Ground

This generator has a system ground that connects the generator frame components to the ground terminals in the AC output receptacles. The system ground is not connected to the AC neutral wire.



## Special Requirements

### NOTICE

*Keep all cooling holes open and clear of debris, mud, water, etc. Cooling holes are located on the front panel, rear panel, and the bottom of the generator. If the cooling holes are blocked, the generator may overheat and damage the engine, inverter, or windings.*

### NOTICE

*Do not lay the generator on its side when moving, storing, or operating it. Oil may leak and damage the engine or your property.*

There may be Federal or State Occupational Safety and Health Administration (OSHA) regulations, local codes, or ordinances that apply to the intended use of the generator. Please consult a qualified electrician, electrical inspector, or the local agency having jurisdiction.

- In some areas, generators are required to be registered with local utility companies.
- If the generator is used at a construction site, there may be additional regulations that must be observed.

# SERVICING YOUR GENERATOR

## THE IMPORTANCE OF MAINTENANCE

Good maintenance is essential for safe, economical, and trouble free operation. It will also help reduce air pollution.

To help you properly care for your generator, the following pages include a maintenance schedule, routine inspection procedures, and simple maintenance procedures using basic hand tools. Other service tasks that are more difficult or require special tools are best handled by professionals and are normally performed by a Honda technician or other qualified mechanic.

The maintenance schedule applies to normal operating conditions. If you operate your generator under unusual conditions, such as sustained high-load or high-temperature operation, or use it in dusty conditions, consult your servicing dealer for recommendations applicable to your individual needs and use.

### **WARNING**

Failure to properly maintain this generator, or failing to correct a problem before operation, could result in a significant malfunction.

Some malfunctions can seriously hurt or kill you.

Always follow the inspection and maintenance recommendations and schedules in this owner's manual.

Remember that an authorized Honda servicing dealer knows your generator best and is fully equipped to maintain and repair it.

To ensure the best quality and reliability, use only new, Honda Genuine parts or their equivalents for repair and replacement.

**Maintenance, replacement, or repair of the emission control devices and systems may be performed by any engine repair establishment or individual, using parts that are “certified” to EPA standards.**

## MAINTENANCE SAFETY

Some of the most important safety precautions follow. However, we cannot warn you of every conceivable hazard that can arise in performing maintenance. Only you can decide whether or not you should perform a given task.

### **WARNING**

Improper maintenance can cause an unsafe condition.

Failure to properly follow maintenance instructions and precautions can cause you to be seriously hurt or killed.

Always follow the procedures and precautions in this owner's manual.

## Safety Precautions

Make sure the engine is off before you begin any maintenance or repairs. This will eliminate several potential hazards:

- **Carbon monoxide poisoning from engine exhaust.**  
Operate outside away from open windows or doors.
- **Burns from hot parts.**  
Let the engine and exhaust system cool before touching.
- **Injury from moving parts.**  
Do not run the engine unless instructed to do so.
- Read the instructions before you begin, and make sure you have the tools and skills required.
- To reduce the possibility of fire or explosion, be careful when working around gasoline. Use only a non-flammable solvent, not gasoline, to clean parts. Keep cigarettes, sparks, and flames away from all fuel-related parts.

# SERVICING YOUR GENERATOR

## MAINTENANCE SCHEDULE

REGULAR SERVICE PERIOD (3) Perform at every indicated month or operating hour interval, whichever comes first.		Each use	First month or 20 Hrs.	Every 3 months or 50 Hrs.	Every 6 months or 100 Hrs.	Every year or 300 Hrs.	Page	
ITEM								
Engine oil	Check level	o					46	
	Change		o		o		48	
Air cleaner	Check	o					51	
	Clean			o (1)			53	
Spark plug	Check-adjust				o		54	
	Replace					o	54	
Spark arrester	Clean				o		56	
Valve clearance	Check-adjust					o (2)	—	
Combustion chamber	Clean	After every 500 Hrs. (2)						—
Fuel tank and filter	Clean					o (2)	—	
Fuel tube	Check	Every 2 years (Replace if necessary) (2)						—

(1) Service more frequently when used in dusty areas.

(2) These items should be serviced by your Honda servicing dealer, unless you have the proper tools and are mechanically proficient. Refer to the Honda shop manual for service procedures. See "Honda Publications" on page 74 for ordering information.

(3) For commercial use, log hours of operation to determine proper maintenance intervals.

Failure to follow this maintenance schedule could result in non-warrantable failures.

## REFUELING

With the engine stopped, remove the fuel filler cap and check the fuel level. Refill the fuel tank if the fuel level is low.

### **WARNING**

Gasoline is highly flammable and explosive.

You can be burned or seriously injured when handling fuel.

- Stop the engine and keep heat, sparks, and flame away when refueling.
- Handle fuel only outdoors.
- Wipe up spills immediately.

### **NOTICE**

*Fuel can damage paint and plastic. Be careful not to spill fuel when filling your fuel tank. Damage caused by spilled fuel is not covered under warranty.*

Refuel in a well-ventilated area before starting the engine. If the engine has been running, allow it to cool. Refuel carefully to avoid spilling fuel. Do not fill above the upper level mark.

Never refuel the engine inside a building where gasoline fumes may reach flames or sparks. Keep gasoline away from appliance pilot lights, barbecues, electric appliances, power tools, etc.

Spilled fuel is not only a fire hazard, it causes environmental damage. Wipe up spills immediately.

# SERVICING YOUR GENERATOR

---

When fueling an empty fuel tank, fill the tank up to the upper level mark. The generator will not start if there is not enough fuel in the tank.

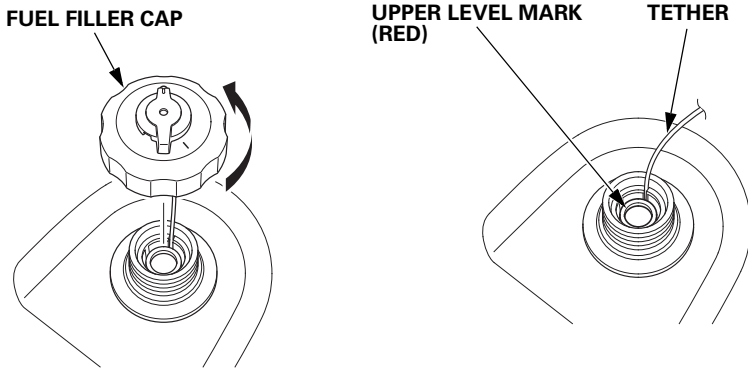

After refueling, tighten the fuel filler cap until it clicks.

## FUEL RECOMMENDATIONS

This engine is certified to operate on regular unleaded gasoline with a pump octane rating of 86 or higher.

Never use gasoline that is stale, contaminated, or mixed with oil. Avoid getting dirt or water in the fuel tank.

You may use regular unleaded gasoline containing no more than 10% ethanol (E10) or 5% methanol by volume. In addition, methanol must contain cosolvents and corrosion inhibitors.

Use of fuels with content of ethanol or methanol greater than shown above may cause starting and/or performance problems. It may also damage metal, rubber, and plastic parts of the fuel system.

Engine damage or performance problems that result from using a fuel with percentages of ethanol or methanol greater than shown above are not covered under warranty.

If your equipment will be used on an infrequent basis, please refer to the fuel section of the STORAGE chapter (see page 58) for additional information regarding fuel deterioration.

# SERVICING YOUR GENERATOR

---

## ENGINE OIL LEVEL CHECK

Check the engine oil level with the generator on a level surface and the engine stopped.

1. Pull the knob and remove the oil maintenance cover.

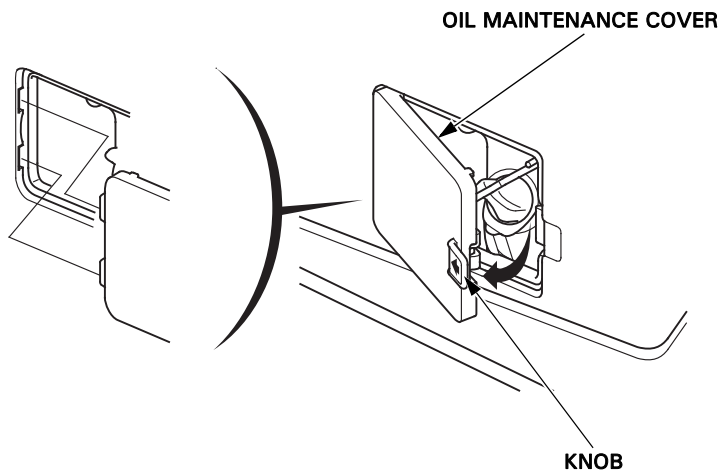



# SERVICING YOUR GENERATOR

2. Remove the oil filler cap.
3. Check the oil level. If it is below the upper limit, fill with the recommended oil (see page 50) to the upper limit.
4. Reinstall the oil filler cap securely.
5. Reinstall the oil maintenance cover.

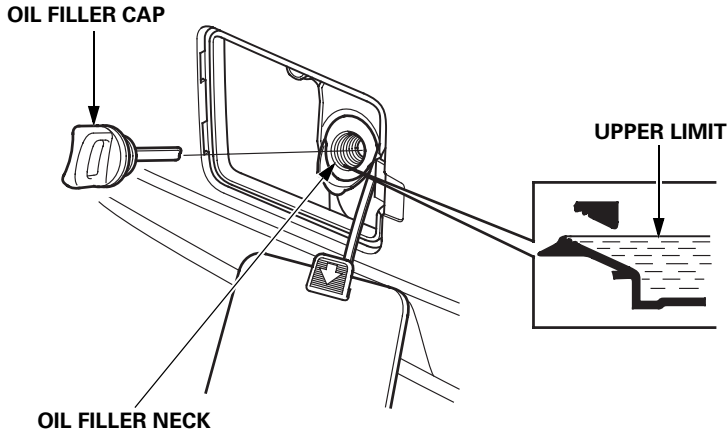

The Oil Alert system will automatically stop the engine before the oil level falls below safe limits. However, to avoid the inconvenience of an unexpected shutdown, check the oil level regularly.

# SERVICING YOUR GENERATOR

---

## ENGINE OIL CHANGE

Drain the oil while the engine is warm to assure rapid and complete draining.

1. Turn the engine switch and fuel filler cap vent lever to the OFF position (see page 26) to reduce the possibility of fuel leakage.
2. Place wood blocks 3.5 in (90 mm) or greater under the generator as shown.

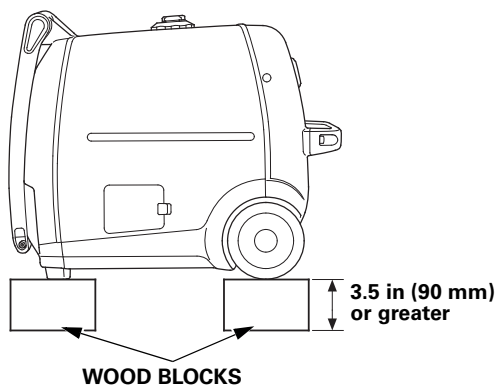

3. Remove the engine oil maintenance cover and oil filler cap.

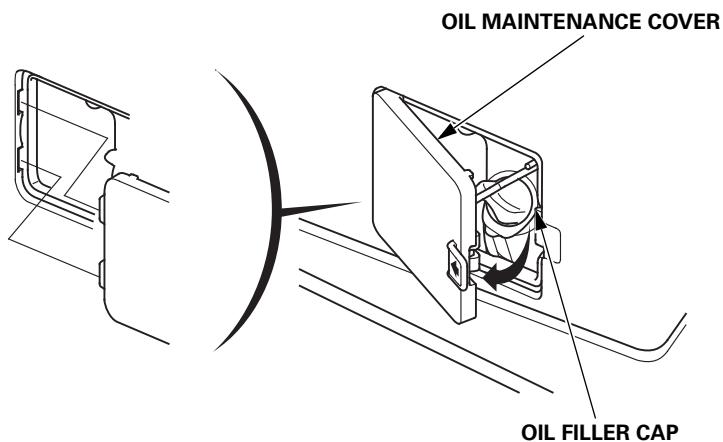

# SERVICING YOUR GENERATOR

4. Open the oil drain plug cover from the bottom of the generator.
5. Place a suitable container below the engine to catch the used oil.
6. Remove the oil drain plug and sealing washer and drain the oil.
7. Reinstall the oil drain plug and a new sealing washer. Tighten the plug securely.
8. Close the oil drain plug cover.

## NOTICE

*Improper disposal of engine oil can be harmful to the environment. If you change your own oil, please dispose of the used oil properly. Put it in a sealed container, and take it to a recycling center. Do not discard it in a trash bin, dump it on the ground, or pour it down the drain.*

9. With the generator in a level position, fill with the recommended oil (see page 50) to the upper limit of the oil filler neck.

**Maximum oil capacity:** 17 oz (0.53 L)

10. Reinstall the oil filler cap securely.
11. Reinstall the oil maintenance cover.

Wash your hands with soap and water after handling used oil.

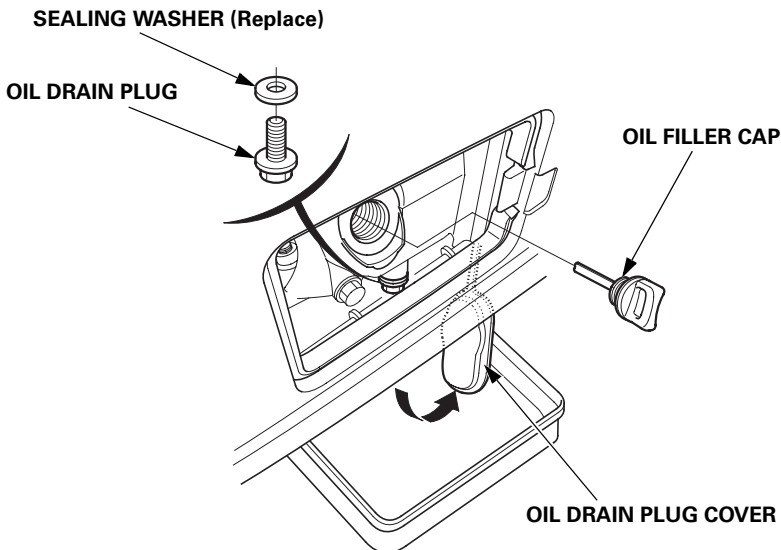

# SERVICING YOUR GENERATOR

---

## ENGINE OIL RECOMMENDATIONS

Oil is a major factor affecting performance and service life. Use 4-stroke automotive detergent oil.

SAE 10W-30 is recommended for general use. Other viscosities shown in the chart may be used when the average temperature in your area is within the recommended range.

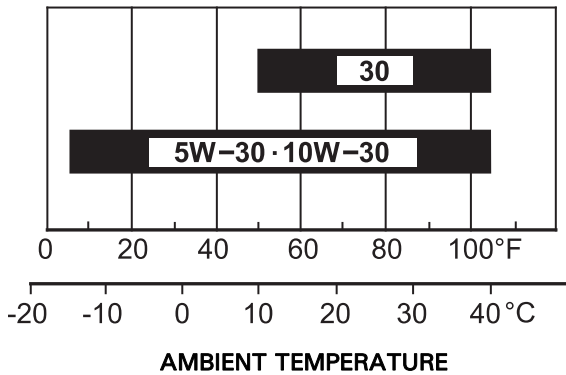

The SAE oil viscosity and service category are in the API label on the oil container. Honda recommends that you use API service category SJ or later (or equivalent) oil.

# SERVICING YOUR GENERATOR

## AIR CLEANER SERVICE

1. Loosen the air cleaner cover screw, and remove the air cleaner cover.

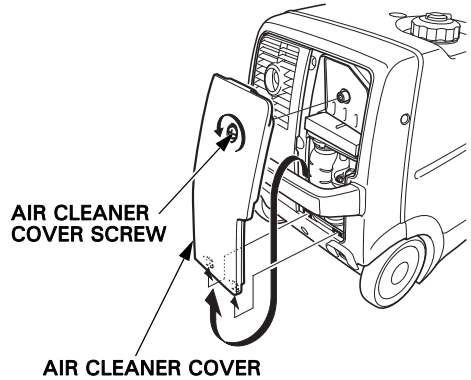

2. Remove the main and outer filters from the air cleaner case.

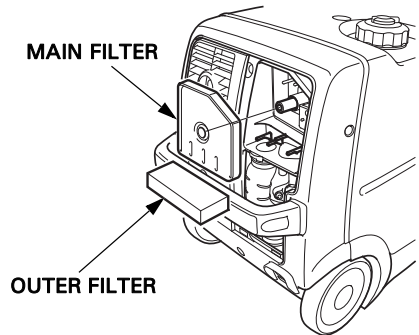

3. Check the main and outer filters to be sure they are clean and in good condition. If the main and outer filters are dirty, clean them as described on page 53. Replace the main and outer filters if they are damaged.

# SERVICING YOUR GENERATOR

4. Make sure that the rubber seal is set in the groove of the air cleaner case. Replace the rubber seal if it is damaged.

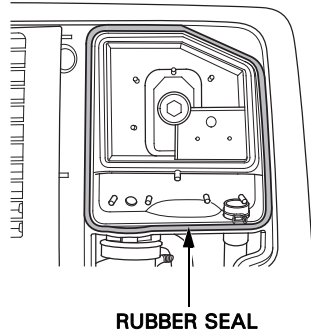

5. Reinstall the air filters. Put the outer filter into the ribs on the air cleaner case.

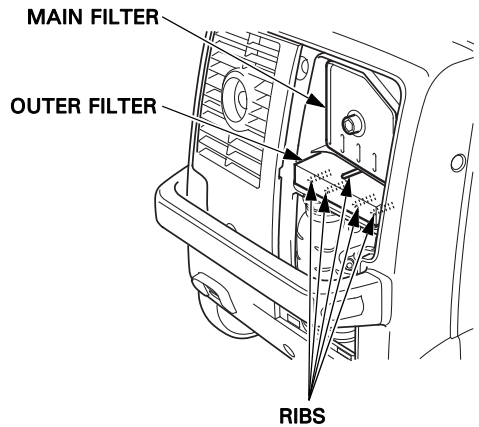

6. Reinstall the air cleaner cover, and tighten the air cleaner cover screw.

## NOTICE

*Operating the engine without an air filter or with a damaged air filter will allow dirt to enter the engine, causing rapid engine wear. This type of damage is not covered by the Distributor's Limited Warranty.*

# SERVICING YOUR GENERATOR

## AIR FILTER CLEANING

A dirty main and outer filters will restrict air flow to the carburetor, reducing engine performance. If you operate the generator in very dusty areas, clean the main and outer filters more frequently than specified in the Maintenance Schedule.

1. Wash the main and outer filters in a solution of household detergent and warm water, then rinse thoroughly, or wash in nonflammable or high flash point solvent. Allow the air filters to dry thoroughly.
2. Soak the main and outer filters in clean engine oil and squeeze out the excess oil. The engine will smoke during initial startup if too much oil is left in the air filters.

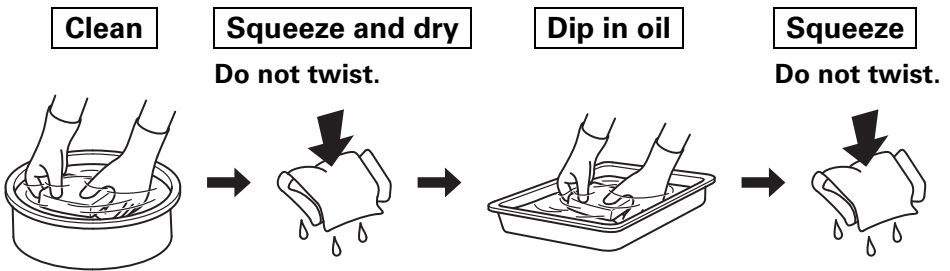

3. Wipe dirt from the air cleaner case and cover using a moist rag. Be careful to prevent dirt from entering the air duct that leads to the carburetor.

# SERVICING YOUR GENERATOR

## SPARK PLUG SERVICE

In order to service the spark plug, you will need a spark plug wrench (commercially available).

**Recommended spark plug:** BPR6ES (NGK)  
W20EPR-U (DENSO)

To ensure proper engine operation, the spark plug must be properly gapped and free of deposits.

### NOTICE

*An incorrect spark plug can cause engine damage.*

If the engine is hot, allow it to cool before servicing the spark plug.

1. Loosen the cover screw and remove the spark plug maintenance cover.

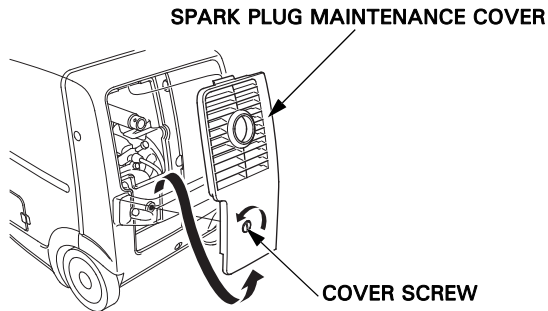

2. Remove the spark plug cap.
3. Clean any dirt from around the spark plug base.
4. Use a spark plug wrench to remove the spark plug.

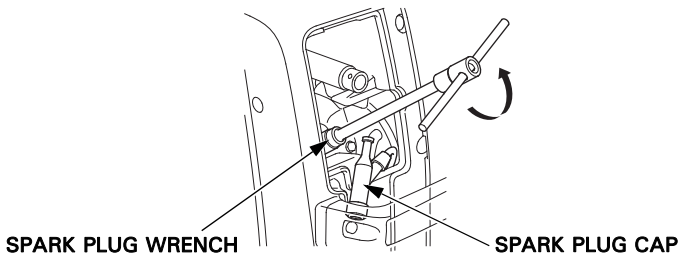



# SERVICING YOUR GENERATOR

5. Inspect the spark plug. Replace it if the electrodes are worn or if the insulator is cracked, chipped, or fouled.

6. Measure the spark plug electrode gap with a wire-type feeler gauge. Correct the gap, if necessary, by carefully bending the side electrode.

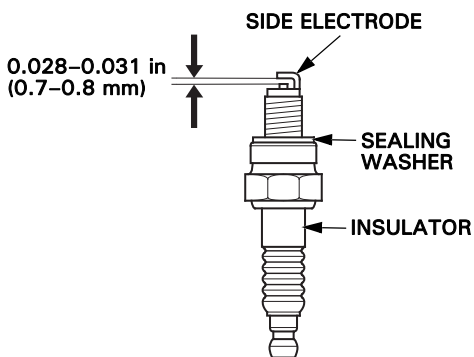

The gap should be:

0.028–0.031 in (0.7–0.8 mm)

7. Make sure that the spark plug sealing washer is in good condition, and thread the spark plug in by hand to prevent cross-threading.

8. After the spark plug is seated, tighten with a spark plug wrench to compress the sealing washer.

If reinstalling a used spark plug, tighten 1/8–1/4 turn after the spark plug seats.

If installing a new spark plug, tighten 1/2 turn after the spark plug seats.

## NOTICE

*A loose spark plug can overheat and damage the engine.*

*Overtightening the spark plug can damage the threads in the cylinder head.*

9. Reinstall the spark plug cap on the spark plug securely.

10. Reinstall the spark plug maintenance cover.

# SERVICING YOUR GENERATOR

---

## SPARK ARRESTER SERVICE

The spark arrester must be serviced every 100 hours to keep it functioning as designed.

If the engine has been running, the muffler will be very hot. Allow the muffler to cool before servicing the spark arrester.

Clean the spark arrester as follows:

1. Loosen the cover screw and remove the spark plug maintenance cover.

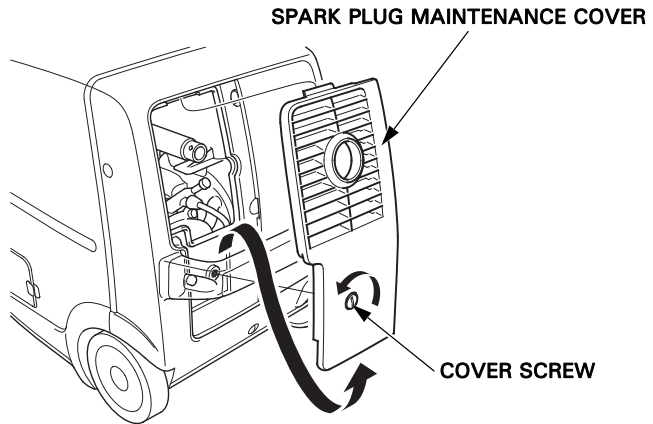

2. Remove the 4 mm self-tapping screw and the spark arrester.

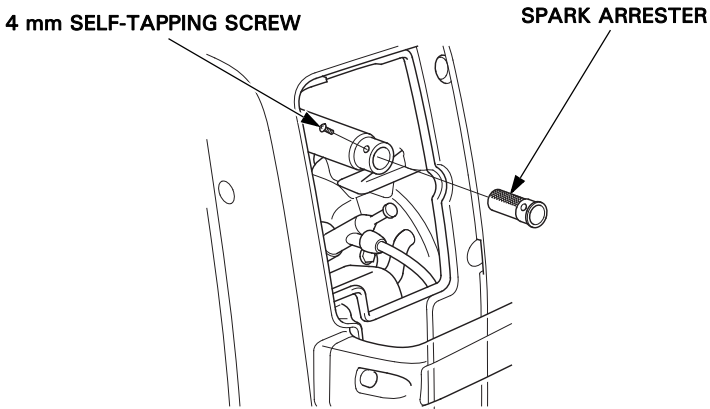

# SERVICING YOUR GENERATOR

---

3. Use a brush to remove carbon deposits from the spark arrester screen.

Be careful to avoid damaging the screen.

The spark arrester must be free of breaks and tears. Replace the spark arrester if it is damaged.



4. Reinstall the spark arrester and spark plug maintenance cover.

# STORAGE

## STORAGE PREPARATION

Proper storage preparation is essential for keeping your generator trouble-free and looking good. The following steps will help to keep rust and corrosion from impairing your generator's function and appearance, and will make the engine easier to start when you use the generator again.

### Cleaning

Wipe the generator with a moist cloth. After the generator has dried, touch up any damaged paint, and coat other areas that may rust with a light film of oil.

### Fuel

#### NOTICE

*Depending on the region where you operate your equipment, fuel formulations may deteriorate and oxidize rapidly. Fuel deterioration and oxidation can occur in as little as 30 days and may cause damage to the carburetor and/or fuel system. Please check with your servicing dealer for local storage recommendations.*

Gasoline will oxidize and deteriorate in storage. Old gasoline will cause hard starting, and it leaves gum deposits that clog the fuel system. If the gasoline in your generator deteriorates during storage, you may need to have the carburetor and other fuel system components serviced or replaced.

The length of time that gasoline can be left in your fuel tank and carburetor without causing functional problems will vary with such factors as gasoline blend, your storage temperatures, and whether the fuel tank is partially or completely filled. The air in a partially filled fuel tank promotes fuel deterioration. Very warm storage temperatures accelerate fuel deterioration. Fuel deterioration problems may occur within a few months, or even less if the gasoline was not fresh when you filled the fuel tank.

The *Distributor's Limited Warranty* does not cover fuel system damage or engine performance problems resulting from neglected storage preparation.

You can extend fuel storage life by adding a gasoline stabilizer that is formulated for that purpose, or you can avoid fuel deterioration problems by draining the fuel tank and carburetor.

Service according to the table below:

<b>STORAGE TIME</b>	<b>RECOMMENDED SERVICE PROCEDURE TO PREVENT HARD STARTING</b>
Less than 1 month	No preparation required
1 to 2 months	Fill with fresh gasoline and add gasoline stabilizer* .
2 months to 1 year	Fill with fresh gasoline and add gasoline stabilizer* . Drain the carburetor float bowl (see page 60 steps 2 ~ 7).
1 year or more	Drain the fuel tank and carburetor (p.60). Change the engine oil and lubricate the cylinder (p.61).
* Use gasoline stabilizers that are formulated to extend storage life. Follow the manufacturer's instructions for use. Contact your authorized Honda generator dealer for stabilizer recommendations.	

## Draining the Fuel Tank and Carburetor

### **⚠ WARNING**

Gasoline is highly flammable and explosive.

You can be burned or seriously injured when handling fuel.

- Stop the engine and keep heat, sparks, and flame away.
- Handle fuel only outdoors.
- Wipe up spills immediately.

1. Unscrew the fuel filler cap (see page 44), remove the fuel filter, and empty the fuel tank into an approved gasoline container. We recommend using a commercially available gasoline hand pump to empty the tank. Do not use an electric pump. Reinstall the fuel filter, and the fuel filler cap.
2. Loosen the cover screw and remove the air cleaner cover (see page 51).
3. Place a suitable container under the drain tube.
4. Turn the engine switch to the ON position to finish draining the fuel tank.  
Leave the engine switch in the OFF position if you are only draining the carburetor (see page 24).
5. Loosen the carburetor drain screw and drain the gasoline from the carburetor.
6. After all the fuel has drained, tighten the drain screw securely.
7. Reinstall the air cleaner cover and turn the engine switch OFF position.

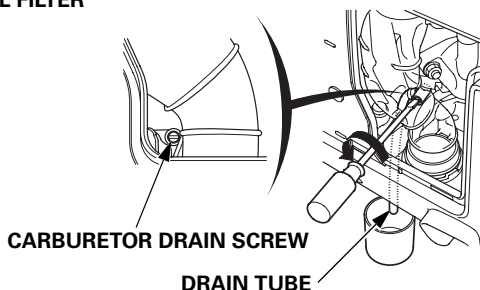
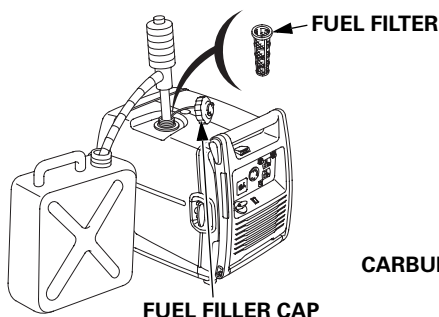

## Engine Oil

Change the engine oil (see page 48).

## Engine Cylinder

1. Remove the spark plug (see page 54), and pour approximately one teaspoon (5 cc) of clean engine oil into the cylinder. Crank the engine several revolutions to distribute the oil, then reinstall the spark plug.
2. Reinstall the spark plug cap on the spark plug securely.
3. Reinstall the spark plug maintenance cover.
4. Pull the starter grip (see page 24) slowly until you feel resistance, then return the starter grip gently. This closes the valves so moisture cannot enter.

# STORAGE

---

## STORAGE PRECAUTIONS

If your generator will be stored with gasoline in the fuel tank and carburetor, it is important to reduce the hazard of gasoline vapor ignition.

Select a well ventilated storage area away from any appliance that operates with a flame, such as a furnace, water heater, or clothes dryer. Also avoid any area with a spark-producing electric motor, or where power tools are operated.

If possible, avoid storage areas with high humidity, because that promotes rust and corrosion.

Unless all fuel has been drained from the fuel tank, leave the engine switch in the OFF position, and the fuel filler cap vent lever in the OFF position (see page 26) to reduce the possibility of leakage.

Place the generator on a level surface. Tilting or laying it on its side can cause fuel or oil leakage.

With the engine and exhaust system cool, cover the generator to keep out dust. A hot engine and exhaust system can ignite or melt some materials.

Do not use a plastic sheet as a dust cover. A nonporous cover will trap moisture around the generator, promoting rust and corrosion.

## REMOVAL FROM STORAGE

Check your generator as described in the *BEFORE OPERATION* chapter of this manual (see page 20).

If the fuel was drained during storage preparation, fill the tank with fresh gasoline. If you keep a container of gasoline for refueling, be sure that it contains only fresh gasoline. Gasoline oxidizes and deteriorates over time, causing hard starting.

If the cylinder was coated with oil during storage preparation, the engine may smoke briefly at startup. This is normal.



# TRANSPORTING

## NOTICE

*Do not lay the generator on its side when moving, storing, or operating it. Oil may leak and damage the engine or your property.*

If the generator has been used, allow it cool for at least 15 minutes before loading the generator on the transport vehicle. A hot engine and exhaust system can burn you and can ignite some material.

To prevent fuel spillage when transporting, the generator should be secured upright in its normal operating position, with the engine switch OFF and the fuel filler cap vent lever turned fully counterclockwise to the OFF position (see page 26).

Take care not to drop or strike the generator when transporting. Do not place heavy objects on the generator.

When using ropes or tie-down straps to secure the generator for transportation, be sure to only use the front and rear handles as attachment points. Do not fasten ropes or straps to any portions of the generator body or the folding handle.

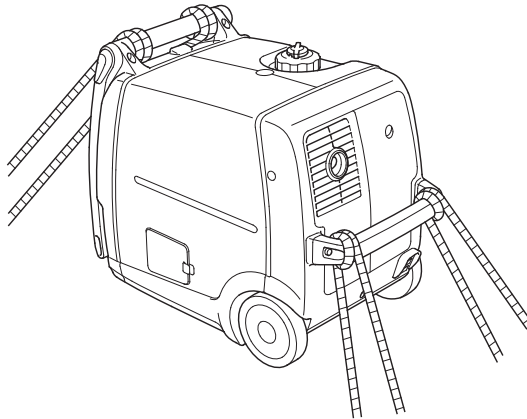

# TAKING CARE OF UNEXPECTED PROBLEMS

## ENGINE WILL NOT START

Possible Cause	Correction
Fuel filler cap vent lever OFF.	Turn lever ON (p. 23).
Engine switch OFF.	Turn engine switch to ON (p. 24).
Out of fuel.	Refuel (p. 43).
Bad fuel; generator stored without treating or draining gasoline, or refueled with bad gasoline.	Drain fuel tank and carburetor (p. 60). Refuel with fresh gasoline (p. 43).
Low oil level caused Oil Alert to stop engine.	Add oil (p. 46). Turn engine switch to OFF and then restart the engine.
Spark plug faulty, fouled, or improperly gapped.	Gap or replace spark plug (p. 54).
Spark plug wet with fuel (flooded engine).	Dry and reinstall spark plug.
Fuel filter restricted, carburetor malfunction, ignition malfunction, valves stuck, etc.	Take the generator to an authorized Honda servicing dealer, or refer to the shop manual.

# TAKING CARE OF UNEXPECTED PROBLEMS

---

## ENGINE LACKS POWER

Possible cause	Correction
Air filter restricted.	Clean or replace air filter (p. 51).
Bad fuel; generator stored without treating or draining gasoline, or refueled with bad gasoline.	Drain fuel tank and carburetor (p. 60). Refuel with fresh gasoline (p. 43).
Fuel filter restricted, carburetor malfunction, ignition malfunction, valves stuck, etc.	Take the generator to an authorized Honda servicing dealer, or refer to the shop manual.

# TAKING CARE OF UNEXPECTED PROBLEMS

---

## NO POWER AT THE AC RECEPTACLES

Possible Cause	Correction
Output indicator is OFF, and overload indicator is ON.	Check AC load. Stop and restart the engine.
	Check the cooling air inlet. Stop and restart the engine.
AC circuit protector tripped.	Check AC load and reset circuit protector (p. 14).
Faulty power tool or appliance.	Replace or repair power tool or appliance. Stop and restart the engine.
Faulty generator.	Take the generator to an authorized Honda servicing dealer, or refer to the shop manual.

## NO POWER AT THE DC RECEPTACLE

Possible Cause	Correction
DC circuit protector OFF.	Turn DC circuit protector ON (p. 15).
Faulty generator.	Take the generator to an authorized Honda servicing dealer, or refer to the shop manual.

# TECHNICAL INFORMATION

## Serial Number Location

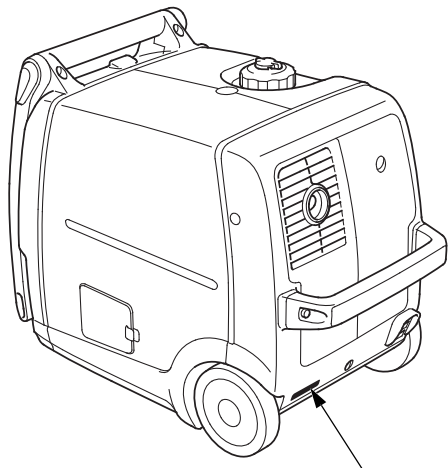

**FRAME SERIAL NUMBER**

Record the frame serial number and date purchased in the spaces below. You will need this information when ordering parts and when making technical or warranty inquiries.

Frame serial number: \_\_\_\_\_

Date purchased: \_\_\_\_\_

# TECHNICAL INFORMATION

---

## Carburetor Modification for High Altitude Operation

At high altitude, the standard carburetor air-fuel mixture will be too rich. Performance will decrease, and fuel consumption will increase. A very rich mixture will also foul the spark plug and cause hard starting. Operation at an altitude that differs from that at which this engine was certified, for extended periods of time, may increase emissions.

High altitude performance can be improved by specific modifications to the carburetor. If you always operate your generator at altitudes above 5,000 feet (1,500 meters), have your authorized Honda servicing dealer perform this carburetor modification. This engine, when operated at high altitude with the carburetor modifications for high altitude use, will meet each emission standard throughout its useful life.

Even with carburetor modification, engine horsepower will decrease about 3.5% for each 1,000-foot (300-meter) increase in altitude. The effect of altitude on horsepower will be greater than this if no carburetor modification is made.

### NOTICE

*When the carburetor has been modified for high altitude operation, the air/fuel mixture will be too lean for low altitude use. Operation at altitudes below 5,000 feet (1,500 meters) with a modified carburetor may cause the engine to overheat and result in serious engine damage. For use at low altitudes, have your servicing dealer return the carburetor to original factory specifications.*

## Emission Control System Information

### Source of Emissions

The combustion process produces carbon monoxide, oxides of nitrogen, and hydrocarbons. Control of hydrocarbons and oxides of nitrogen is very important because, under certain conditions, they react to form photochemical smog when subjected to sunlight. Carbon monoxide does not react in the same way, but it is toxic.

Honda utilizes appropriate air/fuel ratios and other emissions control systems to reduce the emissions of carbon monoxide, oxides of nitrogen, and hydrocarbons.

Additionally, Honda fuel systems utilize components and control technologies to reduce evaporative emissions.

### The U.S. and California Clean Air Acts

EPA and California regulations require all manufacturers to furnish written instructions describing the operation and maintenance of emission control systems.

The following instructions and procedures must be followed in order to keep the Honda engine emissions within the emission standards.

### *Tampering and Altering*

**NOTICE**

*Tampering is a violation of Federal and California law.*

Tampering with or altering the emission control system may increase emissions beyond the legal limit. Among those acts that constitute tampering are:

- Removal or alteration of any part of intake, fuel, or exhaust systems.
- Altering or defeating the governor linkage or speed-adjusting mechanism to cause the engine to operate outside its design parameters.

# TECHNICAL INFORMATION

---

## *Problems That May Affect Emissions*

If you are aware of any of the following symptoms, have your engine inspected and repaired by your authorized Honda servicing dealer.

- Hard starting or stalling after starting.
- Rough idle.
- Misfiring or backfiring under load.
- Afterburning (backfiring).
- Black exhaust smoke or high fuel consumption.

## *Replacement Parts*

The emission control systems on your new Honda engine were designed, built, and certified to conform with applicable emission regulations. We recommend the use of Honda Genuine parts whenever you have maintenance done. These original-design replacement parts are manufactured to the same standards as the original parts, so you can be confident of their performance. The use of replacement parts that are not of the original design and quality may impair the effectiveness of your emission control system.

A manufacturer of an aftermarket part assumes the responsibility that the part will not adversely affect emission performance. The manufacturer or rebuilder of the part must certify that use of the part will not result in a failure of the engine to comply with emission regulations.

## *Maintenance*

Follow the *MAINTENANCE SCHEDULE* on page 42. Remember that this schedule is based on the assumption that your machine will be used for its designed purpose. Sustained high-load or high-temperature operation, or use in dusty conditions, will require more frequent service.



## Air Index (Models sold in California)

An Air Index Information label is applied to engines certified to an emission durability time period in accordance with the requirements of the California Air Resources Board.

The bar graph is intended to provide you, our customer, the ability to compare the emissions performance of available engines. The lower the Air Index, the less pollution.

The durability description is intended to provide you with information relating to the engine's emission durability period. The descriptive term indicates the useful life period for the engine's emission control system. See your *Emission Control System Warranty* (see page 81) for additional information.

Descriptive Term	Applicable to Emission Durability Period
Moderate	50 hours (0–80 cc, inclusive) 125 hours (greater than 80 cc)
Intermediate	125 hours (0–80 cc, inclusive) 250 hours (greater than 80 cc)
Extended	300 hours (0–80 cc, inclusive) 500 hours (greater than 80 cc) 1,000 hours (225 cc and greater)

# TECHNICAL INFORMATION

## Specifications

### Dimensions

Model	EU3000iK1
Description code	EAVJ
Length	24.5 in (622 mm)
Width	14.9 in (379 mm)
Height	19.3 in (489 mm)
Dry mass [weight]	77.6 lbs (35.2 kg)

### Engine

Model	GX160T2
Engine type	4-stroke, overhead valve, single cylinder
Displacement [Bore x Stroke]	9.9 cu-in (163 cm <sup>3</sup> ) [2.68 x 1.77 in (68.0 x 45.0 mm)]
Compression ratio	9.0:1
Engine speed	3,600 – 4,000 rpm (with Eco-Throttle switch OFF)
Cooling system	Forced air
Ignition system	Full transistor
Oil capacity	17 oz (0.53 L)
Fuel tank capacity	1.56 US gal (5.9 L)
Spark plug	BPR6ES (NGK), W20EPR-U (DENSO)

### Generator

Model	EU3000iK1	
Type	A type	
AC output	Rated voltage	120 V
	Rated frequency	60 Hz
	Rated current	21.7 A
	Rated output	2.6 kVA
	Maximum output	3.0 kVA
DC output	Only for charging 12 V automotive batteries. Maximum charging output = 8.3 A	

### Tuneup Specifications

ITEM	SPECIFICATION	MAINTENANCE
Spark plug gap	0.028 – 0.031 in (0.7 – 0.8 mm)	Refer to page 54
Valve clearance (cold)	IN: 0.08 ± 0.02 mm EX: 0.10 ± 0.02 mm	See your authorized Honda dealer.
Other specifications	No other adjustments needed.	

Specifications may vary according to the types, and are subject to change without notice.



# CONSUMER INFORMATION

## Dealer Locator Information

To find an authorized Honda Servicing Dealer anywhere in the United States:

Visit our website:

<http://powerequipment.honda.com/dealer-locator>

## Honda Publications

### ***Shop Manual***

This manual covers complete maintenance and overhaul procedures. It is intended to be used by a skilled technician.

Available through your Honda dealer or visit

<http://powerequipment.honda.com/support/shop-manuals>

### ***Parts Catalog***

This manual provides complete, illustrated parts lists. Available through your Honda dealer.

### ***Accessories***

Your authorized Honda power equipment dealer offers a wide selection of accessories (optional equipment) to make your Generator even more useful.

Visit <http://powerequipment.honda.com/generators/accessories> and click on Generators and Welders to see the entire catalog of accessories.

## Customer Service Information

Honda Power Equipment dealership personnel are trained professionals. They should be able to answer any question you may have. If you encounter a problem that your dealer does not solve to your satisfaction, please discuss it with the dealership's management. The Service Manager or General Manager can help. Almost all problems are solved in this way.

If you are dissatisfied with the decision made by the dealership's management, contact the Honda Power Equipment Customer Relations Office. You can write to:

American Honda Motor Co., Inc.  
Power Equipment Division  
Customer Relations Office  
4900 Marconi Drive  
Alpharetta, Georgia 30005-8847

Or telephone: (770) 497-6400 8:30 am to 7:00 pm ET

When you write or call, please give us this information:

- Model and serial numbers (see page 67)
- Name of the dealer who sold the Generator to you
- Name and address of the dealer who services your Generator
- Date of purchase
- Your name, address, and telephone number
- A detailed description of the problem

# CONSUMER INFORMATION

---

## Distributor's Limited Warranty

This warranty is limited to the following Honda Power Equipment products when distributed by American Honda Motor Co., Inc., Power Equipment Division, 4900 Marconi Drive, Alpharetta, Georgia 30005. The following warranty applies to products purchased at retail or placed in rental service on or after January 1, 2010.

PRODUCTS COVERED BY WARRANTY	LENGTH OF WARRANTY (from date of original retail purchase)	
	PRIVATE RESIDENTIAL (1)	COMMERCIAL/ RENTAL/INSTITUTIONAL
EU3000i generator	36 months	36 months

(1) Private residential: Used in maintaining owner's primary and/or secondary residence. Any other use, including but not limited to informal "for hire" use, is considered commercial/rental/institutional use.

### ***To Qualify for This Warranty:***

The product must be purchased in the United States, Puerto Rico, or the U.S. Virgin Islands from American Honda or a dealer authorized by American Honda to sell those products. This warranty applies to first retail purchaser and each subsequent owner during the applicable warranty time period.

### ***What American Honda Will Repair or Replace Under Warranty:***

American Honda will repair or replace, at its option, any part that is proven to be defective in material or workmanship under normal use during the applicable warranty time period. Warranty repairs and replacements will be made without charge for parts or labor. Anything replaced under warranty becomes the property of American Honda Motor Company, Inc. All parts replaced under warranty will be considered as part of the original product, and any warranty on those parts will expire coincident with the original product warranty.

***To Obtain Warranty Service:***

You must, at your expense, take the Honda Power Equipment product, accessory, replacement part, apparel, or the power equipment on which the accessory or replacement part is installed, and proof of purchase to any Honda Power Equipment dealer in the United States, Puerto Rico, or the U.S. Virgin Islands who is authorized to sell and/or service that product, during the dealer's normal business hours. To locate a dealer near you, visit our web site at <http://powerequipment.honda.com/dealer-locator/>. If you are unable to obtain warranty service or are dissatisfied with the warranty service you receive, contact the owner of the dealership involved; normally this will resolve the problem. However, if you should require further assistance, write or call the Power Equipment Customer Relations Department of American Honda Motor Co., Inc. at the following address:

American Honda Motor Co., Inc.  
Power Equipment Customer Relations Dept.  
4900 Marconi Drive  
Alpharetta, GA 30005-8847 Telephone: (770) 497-6400

# CONSUMER INFORMATION

---

## ***Exclusions:***

1. Any damage or deterioration resulting from the following:
  - Neglect of the periodic maintenance as specified in the product owner's manual
  - Improper repair or maintenance
  - Operating methods other than those indicated in the product owner's manual
  - The use of non-genuine Honda parts and accessories other than those approved by Honda (other than recommended lubricants and fluids)
  - Exposure of the product to soot and smoke, chemical agents, bird droppings, sea water, sea breeze, salt, or other environmental phenomena
  - Collision, fuel contamination or deterioration, neglect, unauthorized alteration, misuse, incorporation or use of unsuitable attachments or parts
  - Normal wear and tear (normal fading of painted or plated surfaces, sheet peeling and other natural deterioration)
2. Consumable parts: Honda does not warrant parts deterioration due to normal wear and tear. The parts listed below are not covered by warranty (unless they are needed as a part of another warranty repair):
  - Spark plug, fuel filter, air cleaner element, clutch disc, tire, wheel bearing, recoil starter rope, cable, belt, cutter blade
  - Lubricant: oil and grease
3. Cleaning, adjustment, and normal periodic maintenance work (carburetor cleaning, engine oil draining, blade sharpening, belt and cable adjustments).
4. Any product that has ever been declared a total loss or sold for salvage by a financial institution or insurer.
5. Auger and paddle assemblies of snowthrowers, tiller tines of rototillers, mower blades and mower deck housings, are specifically not warranted against impact damage, including but not limited to, abrasive damage.

## ***Disclaimer of Consequential Damage and Limitation of Implied Warranties:***

American Honda disclaims any responsibility for loss of time or use of the product, transportation, commercial loss, or any other incidental or consequential damage. Any implied warranties are limited to the duration of this written limited warranty. Some states do not allow limitations on how long an implied warranty lasts and/or do not allow the exclusion or limitation of incidental or consequential damages, so the above exclusions and limitations may not apply to you. This warranty gives you specific legal rights, and you may also have other rights, which vary from state to state.



## Honda Parts, Accessories, and Apparel

This warranty is limited to Honda Power Equipment parts, accessories, and apparel when distributed by American Honda Motor Co., Inc., 4900 Marconi Drive, Alpharetta, Georgia 30005-8847.

PRODUCTS COVERED BY WARRANTY	LENGTH OF WARRANTY (from date of original retail purchase)	
	PRIVATE RESIDENTIAL	COMMERCIAL/ RENTAL/INSTITUTIONAL
Accessories	12 months	3 months
Parts	6 months	3 months
Apparel	6 months	3 months

### *To Qualify for This Warranty:*

1. The parts, accessories, or apparel must be purchased from American Honda or a dealer authorized by American Honda to sell those products in the United States, Puerto Rico, and the U.S. Virgin Islands. Parts and accessories must be purchased for installation on original Honda equipment or engines to be eligible for warranty coverage. Installing parts and accessories on non-Honda products or engines voids this warranty.
2. You must be the first retail purchaser. This warranty is not transferable to subsequent owners.

### *What American Honda Will Repair or Replace Under Warranty:*

American Honda will repair or replace, at its option, any Honda Power Equipment parts, accessories, or apparel that are proven to be defective in material or workmanship under normal use during the applicable warranty time period. Anything replaced under warranty becomes the property of American Honda Motor Company, Inc. The warranty on all parts, accessories, and apparel replaced under warranty will expire coincident with the original warranty on the replaced parts, accessories, or apparel.

Parts and accessories installed by a dealer who is authorized by American Honda to sell them will be repaired or replaced under warranty without charge for parts or labor. If installed by anyone else, parts and accessories will be repaired or replaced under warranty without charge for parts, but any labor charges will be the responsibility of the purchaser. Apparel will be repaired or replaced under warranty without any charge.

# CONSUMER INFORMATION

---

## ***To Obtain Warranty Service:***

You must, at your expense, take the Honda Power Equipment part, accessory, or apparel, or the Honda Power Equipment on which the accessory or part is installed, and proof of purchase to any Honda Power Equipment dealer in the United States, Puerto Rico, or the U.S. Virgin Islands who is authorized to sell that product, during the dealer's normal business hours. To locate a dealer near you, visit our web site at <http://powerequipment.honda.com/dealer-locator/>. If you are unable to obtain warranty service or are dissatisfied with the warranty service you receive, contact the owner of the dealership involved; normally this will resolve the problem. However, if you should require further assistance, write or call the Power Equipment Customer Relations Department of American Honda Motor Co., Inc. Refer to page 77 for contact information.

## ***Exclusions:***

This warranty does not extend to parts, accessories, or apparel affected or damaged by collision, normal wear, use in an application for which the product was not designed, or any other misuse, neglect, incorporation or use of unsuitable attachments or parts, unauthorized alteration, improper installation, or any causes other than defects in material or workmanship of the product. Installing parts and accessories on non-Honda products or engines voids this warranty.

## ***Disclaimer of Consequential Damage and Limitation of Implied Warranties:***

American Honda disclaims any responsibility for loss of time or use of the product, or the power equipment on which the product is installed, transportation, commercial loss, or any other incidental or consequential damage. Any implied warranties are limited to the duration of this written warranty. Some states do not allow limitations on how long an implied warranty lasts and/or do not allow the exclusion or limitation of incidental or consequential damages, so the above exclusions and limitations may not apply to you. This warranty gives you specific legal rights, and you may also have other rights, which vary from state to state.

## **Emission Control System Warranty**

Your new Honda Power Equipment engine complies with the U.S. EPA, Environment Canada, and State of California (models certified for sale in California only) emission regulations. American Honda Motor Co., Inc. provides the emission warranty coverage for engines in the United States and its territories. Honda Canada Inc. provides the emission warranty for engines in the 13 provinces and territories of Canada. In the remainder of this Emission Control System Warranty, American Honda Motor Company Inc. and Honda Canada Inc. will be referred to as Honda.

### ***Your Warranty Rights And Obligations***

#### ***California***

The California Air Resources Board and Honda are pleased to explain the emission control system warranty on your 2015 and later Honda Power Equipment engine. In California, new spark-ignited small off-road equipment engines must be designed, built, and equipped to meet the state's stringent anti-smog standards. Specific Honda products that do not meet the California emissions regulations can be identified by a "Not for Sale in California" decal.

#### ***Other States, U.S. territories, and Canada***

In other areas of the United States and in Canada, your engine must be designed, built, and equipped to meet the U.S. EPA and Environment Canada emission standards for spark-ignited engines at or below 19 kilowatts.

#### ***All of the United States and Canada***

Honda must warrant the emission control system on your power equipment engine for the period of time listed below, provided there has been no abuse, neglect, or improper maintenance of your power equipment engine. Where a warrantable condition exists, Honda will repair your power equipment engine at no cost to you including diagnosis, parts, and labor.

Your emission control system may include such parts as the carburetor or fuel injection system, the ignition system, and catalytic converter. Also included may be hoses, connectors, and other emission-related assemblies (see page 85 for additional covered parts).

# CONSUMER INFORMATION

---

## *Owner's Warranty Responsibility*

As the power equipment engine owner, you are responsible for completing all required maintenance listed in your owner's manual. Honda recommends that you retain all receipts covering maintenance on your power equipment engine, but Honda cannot deny warranty coverage solely for the lack of receipts or for your failure to ensure that all scheduled maintenance has been completed.

As the power equipment engine owner, you should however be aware Honda may deny you warranty coverage if your power equipment engine or a part has failed due to abuse, neglect, improper maintenance, or unapproved modifications.

You are responsible for presenting your power equipment engine to a Honda Power Equipment dealer as soon as a problem exists. The emission related warranty repairs should be completed in a reasonable amount of time, not to exceed 30 days.

If you have any questions regarding your emission warranty rights and responsibilities, you should contact the Honda Office in your region:

American Honda Motor Co., Inc.  
Power Equipment Customer  
Relations  
4900 Marconi Drive  
Alpharetta, Georgia 30005-8847  
Telephone: (888) 888-3139  
Email: [powerequipmentemissions@ahm.honda.com](mailto:powerequipmentemissions@ahm.honda.com)

Honda Canada Inc.  
Power Equipment  
Customer Relations  
or 180 Honda Blvd,  
Markham, ON L6C 0H9  
Telephone: (888) 946-6329

## ***Warranty Coverage***

Honda power equipment engines sold in the United States and Canada are covered by this warranty for a period of two years from the date of delivery to the original retail purchaser or the length of the *Honda Distributor's Limited Warranty*, whichever is longer. This warranty is transferable to each subsequent purchaser for the duration of the warranty period.

If any emission-related part on your engine is defective, the part will be repaired or replaced by Honda without charge for diagnosis, parts, or labor. All defective parts replaced under this warranty become the property of Honda. Only Honda-approved replacement parts may be used in the performance of any warranty repairs and must be provided without charge to the owner. A list of warranted parts is on page 85. Normal maintenance items, such as spark plugs and filters, that are on the warranted parts list are warranted up to their required replacement interval only.

Honda will also replace other engine components damaged by a failure of any warranted part during the warranty period.

The use of replacement parts not equivalent to the original parts may impair the effectiveness of your engine emission control system. If such a replacement part is used in the repair or maintenance of your engine, and an authorized Honda dealer determines it is defective or causes a failure of a warranted part, your claim for repair of your engine may be denied. If the part in question is not related to the reason your engine requires repair, your claim will not be denied.

# CONSUMER INFORMATION

---

## To Obtain Warranty Service

You must, at your own expense, take your Honda Power Equipment engine or the product on which it is installed, along with your sales registration card or other proof of original purchase date, to any Honda Power Equipment dealer who is authorized by Honda to sell and service that Honda product during their normal business hours.

Claims for repair or adjustment found to be caused solely by defects in material or workmanship will not be denied because the engine was not properly maintained and used.

If you are unable to obtain emission warranty service or are dissatisfied with the warranty service you received, contact the owner of the dealership involved. Normally this should resolve your problem. However, if you require further assistance, contact the Honda office in your region:

American Honda Motor Co., Inc.  
Power Equipment Customer  
Relations

4900 Marconi Drive  
Alpharetta, Georgia 30005-8847  
Telephone: (888) 888-3139

Email: [powerequipmentemissions@ahm.honda.com](mailto:powerequipmentemissions@ahm.honda.com)

or

Honda Canada Inc.  
Power Equipment  
Customer Relations

180 Honda Blvd,  
Markham, ON L6C 0H9  
Telephone: (888) 946-6329

## Exclusions

Failures other than those resulting from defects in material or workmanship are not covered by this warranty. This warranty does not extend to emission control systems or parts that are affected or damaged by owner abuse, neglect, improper maintenance, misuse, misfueling, improper storage, collision, the incorporation of, or use of, unsuitable attachments, or the unauthorized alteration of any part.

This warranty does not cover replacement of expendable maintenance items made in connection with required maintenance service after the item's first scheduled replacement as listed in the maintenance section of the product owner's manual, such as: spark plugs and filters.

# CONSUMER INFORMATION

## ***Disclaimer of Consequential Damage and Limitation of Implied Warranties***

American Honda Motor Co., Inc. and Honda Canada Inc. disclaim any responsibility for incidental or consequential damages such as loss of time or the use of the power equipment, or any commercial loss due to the failure of the equipment; and any implied warranties are limited to the duration of this written warranty. This warranty is applicable only where the California, U.S. EPA, or Environment Canada emission control system warranty regulation is in effect.

## ***Emission Control System Warranty Parts***

<b>SYSTEMS COVERED BY THIS WARRANTY:</b>	<b>PARTS DESCRIPTION:</b>
Fuel Metering	Carburetor assembly, (includes starting enrichment system), Oxygen sensor, Throttle body, Engine temperature sensor, Engine control module, Fuel injector, Fuel regulator, Intake manifold
Evaporative	Fuel tank, Fuel cap, Fuel hoses, Vapor hoses, Carbon canister, Canister mounting brackets, Fuel strainer, Fuel valve, Fuel pump, Fuel hose joint, Canister purge hose joint
Exhaust	Catalyst, Exhaust pipe, Muffler (with catalyst)
Air Induction	Air cleaner case, Air cleaner element*
Ignition	Flywheel comp., Flywheel magneto, Ignition pulse generator, Crankshaft position sensor, Power coil, Ignition coil assembly, Ignition control module, Spark plug cap, Spark plug*
Crankcase Emission Control	Crankcase breather tube, Breather valve assembly, Oil filler cap
Miscellaneous Parts	Tubeing, fittings, seals, gaskets, and clamps associated with these listed systems.

Note: This list applies to parts supplied by Honda and does not cover parts supplied by the equipment manufacturer. Please see the original equipment manufacturer's emissions warranty for non-Honda parts.

\* Covered up to the first required replacement only.

See the *MAINTENANCE SCHEDULE* on page 42.

# INITIAL USE INSTRUCTIONS

## ENGINE OIL

The generator is shipped **WITHOUT OIL** in the engine.

1. Place the generator on a level surface.
2. Pull the knob and remove the oil maintenance cover.

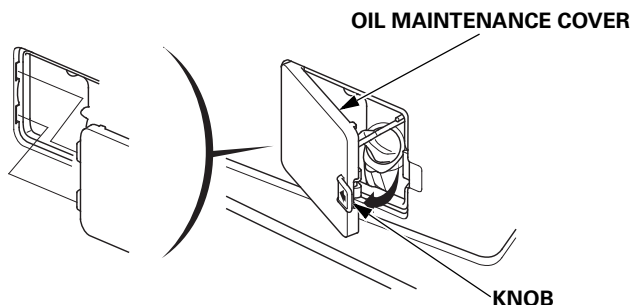

3. Remove the oil filler cap and add enough SAE 10W-30 API service category SJ or later (or equivalent) oil to bring the oil level to the upper limit of the oil filler neck. SAE 10W-30 oil is recommended for general use; for additional recommendations, see page 50.

**Maximum oil capacity:** 17 oz (0.53 L)

Do not overfill the engine with oil. If the engine is overfilled, the excess oil may be transferred to the air cleaner case and air filter.

4. Screw in the oil filler cap securely.

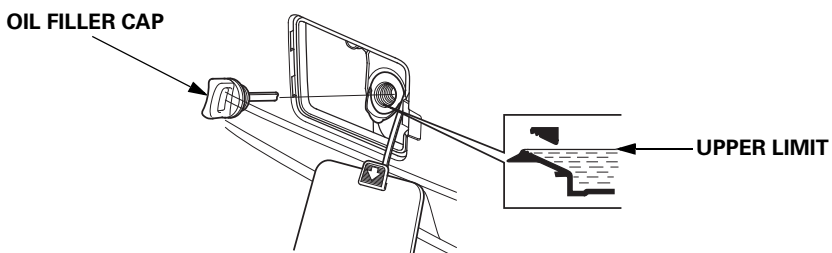

5. Reinstall the oil maintenance cover.



# INITIAL USE INSTRUCTIONS

## FUEL

Add fuel to the generator in a well-ventilated area. Never refuel the engine inside a building where gasoline fumes may reach flames or sparks. Keep gasoline away from appliance pilot lights, barbecues, electric appliances, power tools, etc. Spilled fuel is not only a fire hazard, it causes environmental damage. Wipe up spills immediately.

This engine is certified to operate on unleaded gasoline with a pump octane rating of 86 or higher. Refer to page 45 for additional fuel recommendations.

### **⚠ WARNING**

Gasoline is highly flammable and explosive.

You can be burned or seriously injured when handling fuel.

- Stop the engine and keep heat, sparks, and flame away when refueling.
- Handle fuel only outdoors.
- Wipe up spills immediately.

1. Remove the fuel filler cap.

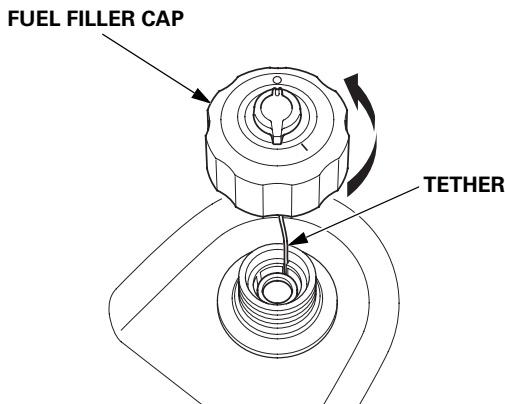

# INITIAL USE INSTRUCTIONS

2. Fuel carefully to avoid spilling fuel. Do not fill the fuel tank above the upper level mark (red) on the fuel strainer.

When fueling an empty fuel tank, fill the tank up to the upper level mark. The generator will not start if there is not enough fuel in the tank.

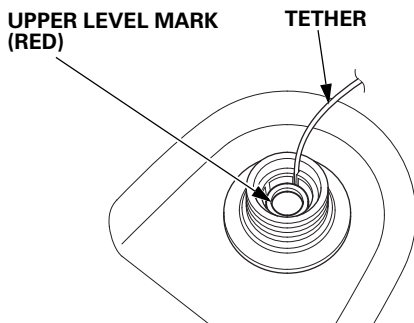

## NOTICE

*Fuel can damage paint and plastic. Be careful not to spill fuel when filling your fuel tank. Damage caused by spilled fuel is not covered under warranty.*

3. After refueling, tighten the fuel filler cap securely until it clicks. Keep the fuel filler cap vent lever OFF for storage or transport, and ON to run the generator.

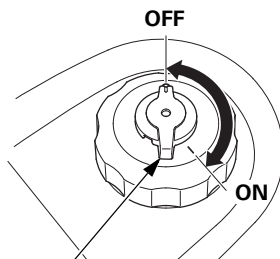

FUEL FILLER CAP VENT LEVER

Move the generator at least 10 feet (3 meters) away from the fueling source and site before starting the engine.

After initial fueling (or anytime the generator is run completely out of fuel), starting the engine may require additional pulls of the starter grip. This generator utilizes a vacuum operated fuel pump and may require additional pulls to draw fuel into the carburetor.

## BEFORE OPERATION

Before using the generator, all generator operators must read the following chapters and sections:

- **GENERATOR SAFETY** (pages 6–9)
- **CONTROLS & FEATURES** (pages 10–19)
- **BEFORE OPERATION** (pages 20–21)
- **OPERATION** (page 22)
- **STARTING THE ENGINE** (pages 23–25)
- **STOPPING THE ENGINE** (pages 26–27)
- **MAINTENANCE SCHEDULE** (page 42)

## REGISTRATION

### **Please Register Your Generator**

If your dealer did not collect registration information from you, please take a few minutes and register your purchase with Honda. This allows us to contact you with any important updates regarding your generator. Please note registration is not required to obtain warranty service. You can register your generator by visiting the Honda Power Equipment website, <http://powerequipment.honda.com/support> and click on Product Registration. Your information will remain confidential. It will not be released to any other company or organization.

# INDEX

<b>A</b>	
AC Applications .....	29
AC Circuit Protectors .....	14
AC OPERATION .....	28
AC PARALLEL OPERATION .....	30
AC Parallel Operation Applications .....	32
AIR CLEANER SERVICE .....	51
AIR FILTER CLEANING .....	53
Air Index .....	71
ARE YOU READY TO GET STARTED? .....	20
<b>B</b>	
BEFORE OPERATION .....	20, 89
<b>C</b>	
Carbon Monoxide Hazards .....	6
Carburetor Modification for High Altitude Operation .....	68
Check the Engine .....	21
Cleaning .....	58
COMPONENT & CONTROL LOCATIONS .....	10
Connections to a Building's Electrical System .....	38
CONSUMER INFORMATION .....	74
CONTENTS .....	3
CONTROLS .....	12
CONTROLS & FEATURES .....	10
Customer Service Information .....	75
<b>D</b>	
DC Circuit Protector .....	15
DC OPERATION .....	34
DC Receptacle .....	15
Dealer Locator Information .....	74
Distributor's Limited Warranty .....	76

<b>E</b>	
Eco-Throttle Switch .....	13
ECO-THROTTLE SYSTEM.....	37
Electric Shock Hazards .....	7
Emission Control System Information.....	69
Emission Control System Warranty .....	81
Engine Cylinder.....	61
ENGINE LACKS POWER.....	65
Engine Oil.....	61, 86
ENGINE OIL CHANGE.....	48
ENGINE OIL LEVEL CHECK .....	46
ENGINE OIL RECOMMENDATIONS .....	50
Engine Switch .....	12
ENGINE WILL NOT START .....	64
<b>F</b>	
FEATURES.....	17
Fire and Burn Hazards.....	7
Folding Handle.....	16
Fuel .....	58, 87
FUEL RECOMMENDATIONS.....	45
Fuel Filler Cap Vent Lever .....	13
<b>G</b>	
GENERATOR SAFETY.....	6
Ground Terminal.....	17
<b>H</b>	
Honda Publications.....	74
<b>I</b>	
IMPORTANT SAFETY INFORMATION .....	6
INITIAL USE INSTRUCTIONS .....	86
IS YOUR GENERATOR READY TO GO?.....	20
<b>K</b>	
Knowledge .....	20

# INDEX

---

<b>M</b>	
MAINTENANCE SAFETY .....	41
MAINTENANCE SCHEDULE .....	42
<b>N</b>	
NO POWER AT THE AC RECEPTACLES .....	66
NO POWER AT THE DC RECEPTACLE .....	66
<b>O</b>	
Oil Alert Indicator .....	19
OPERATION.....	22
Operator Responsibility .....	6
Output Indicator .....	18
Overload Indicator .....	19
<b>P</b>	
Parallel Operation Outlets .....	14
<b>Q</b>	
QUICK REFERENCE INFORMATION .....	Inside back cover
<b>R</b>	
REFUELING.....	43
Refuel With Care .....	8
REGISTRATION.....	89
REMOVAL FROM STORAGE .....	62

<b>S</b>	
SAFE OPERATING PRECAUTIONS .....	22
SAFETY LABEL LOCATIONS .....	9
Safety Precautions .....	41
Serial Number Location .....	67
SERVICING YOUR GENERATOR .....	40
SPARK ARRESTER SERVICE .....	56
SPARK PLUG SERVICE .....	54
Special Requirements .....	39
Specifications .....	72
STANDBY POWER .....	38
Starter Grip .....	12
STARTING THE ENGINE .....	23
STOPPING THE ENGINE .....	26
STORAGE .....	58
STORAGE PRECAUTIONS .....	62
STORAGE PREPARATION .....	58
System Ground .....	38
<b>T</b>	
TAKING CARE OF UNEXPECTED PROBLEMS .....	64
TECHNICAL INFORMATION .....	67
THE IMPORTANCE OF MAINTENANCE .....	40
TRANSPORTING .....	63
<b>W</b>	
Wiring Diagram .....	73

---

**MEMO**



---

## MEMO

---

## MEMO

# QUICK REFERENCE INFORMATION

Fuel	Type	Regular unleaded gasoline with an ethanol content of no more than 10% and a pump octane rating of 86 or higher
Engine Oil	Type	SAE 10W-30, API SJ or later (or equivalent), for general use (page 50) Maximum oil capacity: 17 oz (0.53 L)
Spark Plug	Type	BPR6ES (NGK) W20EPR-U (DENSO)
	Electrode Gap	0.028–0.031 in (0.7–0.8 mm)
Maintenance	Before each use	Check engine oil level. Check air filter.
	First 20 hours	Change engine oil.
	Subsequent	See Maintenance Schedule (page 42)

# HONDA

The Power of Dreams

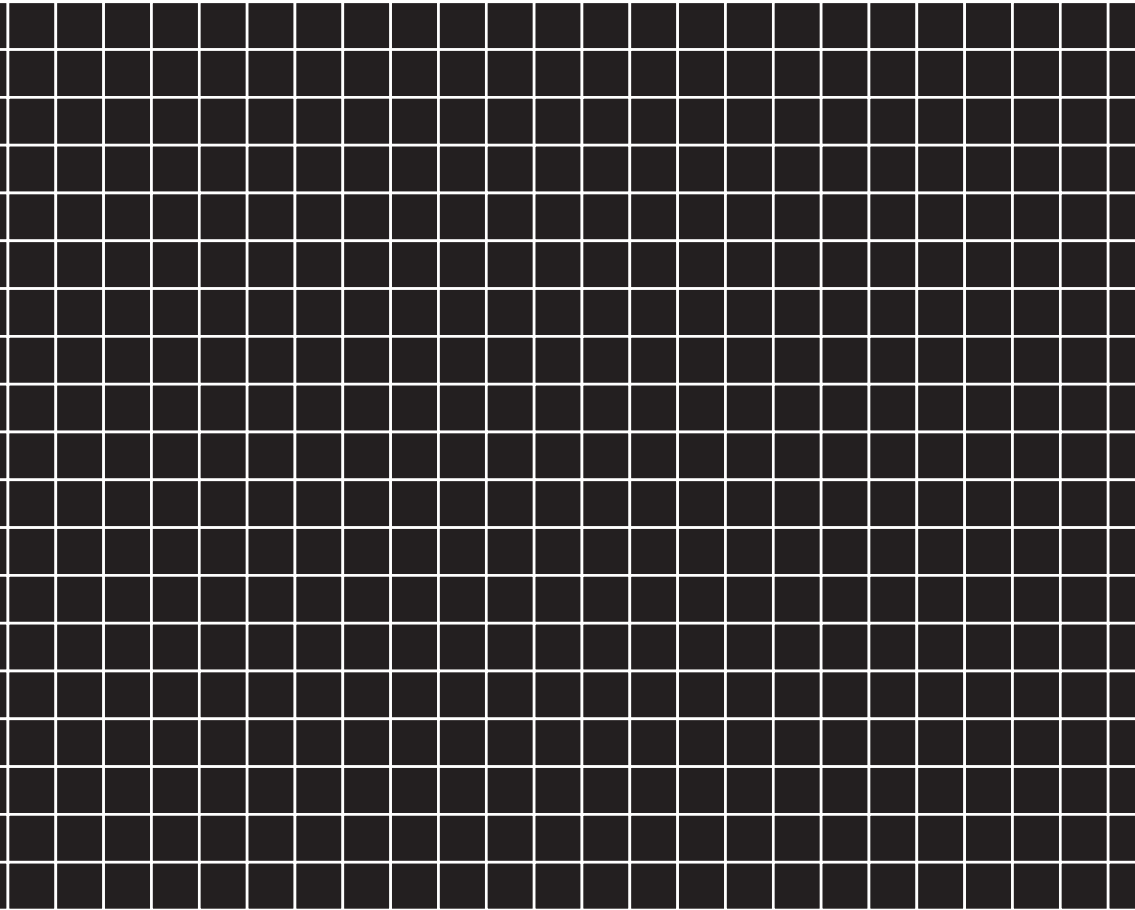

HFZG Î FG  
€YHFZG Æ FGE

EM4

AH 英 Y  
Hi

HC Hcecefi H  
Printed in China

K1