

HONDA

Power

Equipment

Owner's Manual
SNOW BLOWER
HSS928A•HSS1332A

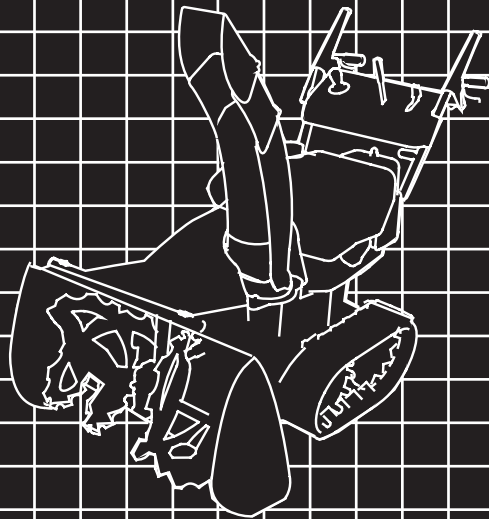

00X31V45 A140



WARNING:



The engine exhaust from this product contains chemicals known to the State of California to cause cancer, birth defects or other reproductive harm.

California Proposition 65

This product contains or emits chemicals known to the state of California to cause cancer, birth defects or other reproductive harm

Keep this owner's manual handy, so you can refer to it any time. This owner's manual is considered a permanent part of the snow blower and should remain with the snow blower if resold.

INTRODUCTION

Congratulations on your selection of a Honda snow blower! We are certain you will be pleased with your purchase of one of the finest snow blowers on the market.

We want to help you get the best results from your new snow blower and to operate it safely. This manual contains the information on how to do that; please read it carefully.

As you read this manual, you will find information preceded by a **NOTICE** symbol. That information is intended to help you avoid damage to your snow blower, other property, or the environment.

We suggest you read the warranty policy to fully understand its coverage and your responsibilities of ownership. The warranty policy is located in the back of this manual.

When your snow blower needs scheduled maintenance, keep in mind that your Honda servicing dealer is specially trained in servicing Honda snow blowers. Your Honda servicing dealer is dedicated to your satisfaction and will be pleased to answer your questions and concerns.

Best Wishes,
American Honda Motor Co., Inc.

INTRODUCTION

A FEW WORDS ABOUT SAFETY

Your safety and the safety of others are very important. And using this snowblower safely is an important responsibility.

To help you make informed decisions about safety, we have provided operating procedures and other information on labels and in this manual. This information alerts you to potential hazards that could hurt you or others.

Of course, it is not practical or possible to warn you about all the hazards associated with operating or maintaining a snow blower. You must use your own good judgment.

You will find important safety information in a variety of forms, including:

- **Safety Labels** — on the snow blower.
- **Safety Messages** — preceded by a safety alert symbol  and one of three signal words, DANGER, WARNING, or CAUTION.

These signal words mean:

 **DANGER**

You **WILL** be KILLED or SERIOUSLY HURT if you don't follow instructions.

 **WARNING**

You **CAN** be KILLED or SERIOUSLY HURT if you don't follow instructions.

 **CAUTION**

You **CAN** be HURT if you don't follow instructions.

- **Safety Headings** — such as *IMPORTANT SAFETY INFORMATION*.
- **Safety Section** — such as *SNOW BLOWER SAFETY*.
- **Instructions** — how to use this snow blower correctly and safely.

This entire book is filled with important safety information — please read it carefully.

CONTENTS

SNOW BLOWER SAFETY	5
IMPORTANT SAFETY INFORMATION.....	5
SAFETY LABEL LOCATIONS.....	8
INITIAL USE INSTRUCTIONS	9
LIST OF LOOSE PARTS.....	9
ADD ENGINE OIL.....	10
REGISTER YOUR SNOW BLOWER	11
BEFORE USING YOUR SNOW BLOWER.....	11
CONTROLS & FEATURES	12
COMPONENT & CONTROL LOCATIONS.....	12
CONTROLS.....	14
Engine Switch.....	14
Auger Lock Indicator HSS1332A (ATD only).....	14
Fuel Valve Lever and Fuel Gauge	15
Throttle Lever and Choke Knob	16
Shift Lever	17
Chute Joystick Control.....	17
Drive Clutch Lever and Auger Clutch Lever	18
Steering Control Levers	19
Height Adjust Lever (AT, ATD track models).....	21
FEATURES	22
LED Work Light.....	22
Snow Clearing Bar.....	22
Hour Meter HSS1332A (ATD only)	23
Auger Lock Indicator HSS1332A (ATD only).....	24
BEFORE OPERATION	25
ARE YOU READY TO GET STARTED?.....	25
IS YOUR SNOW BLOWER READY TO GO?	25
Check the General Condition of the Snow Blower:.....	26
CHECK YOUR WORK AREA.....	27
OPERATION	28
SNOW BLOWING PRECAUTIONS	28
STARTING THE ENGINE	29
STOPPING THE ENGINE	32
CLEARING SNOW.....	35
SNOW-CLEARING TIPS	37
REMOVING OBSTRUCTIONS	38
SERVICING YOUR SNOW BLOWER	39
THE IMPORTANCE OF MAINTENANCE	39
MAINTENANCE SAFETY	40
TOOL KIT	41
MAINTENANCE SCHEDULE	42

CONTENTS

REFUELING.....	44
FUEL RECOMMENDATIONS.....	45
ENGINE OIL LEVEL CHECK	46
ENGINE OIL CHANGE.....	47
ENGINE OIL RECOMMENDATIONS	48
SPARK PLUG SERVICE.....	49
TRACK ADJUSTMENT	51
TIRE INSPECTION.....	52
AUGER AND BLOWER INSPECTION.....	52
SHEAR BOLT REPLACEMENT	53
SKID SHOES AND SCRAPER.....	54
STORAGE.....	56
STORAGE PREPARATION.....	56
Cleaning.....	56
Fuel.....	57
Draining Fuel Tank and Carburetor	59
Engine Oil.....	60
Tires.....	60
Battery Service (ATD, AWD).....	60
STORAGE PRECAUTIONS	63
REMOVAL FROM STORAGE	63
TRANSPORTING.....	64
BEFORE LOADING	64
LOADING	65
TAKING CARE OF UNEXPECTED PROBLEMS	67
ENGINE PROBLEMS	67
DRIVE PROBLEMS	68
SNOW BLOWER PROBLEMS	68
TECHNICAL INFORMATION	70
Serial Number Locations.....	70
Carburetor Modification for High Altitude Operation	71
Emission Control System Information.....	72
Air Index	74
Specifications	75
CONSUMER INFORMATION	77
Dealer Locator Information	77
Honda Publications	77
Customer Service Information	78
DISTRIBUTOR'S LIMITED WARRANTY	80
EMISSION CONTROL SYSTEM WARRANTY	82
QUICK REFERENCE INFORMATION.....	Inside back cover

SNOW BLOWER SAFETY

IMPORTANT SAFETY INFORMATION

Honda snow blowers are designed to clear snow from driveways and walkways. Other uses can result in injury to the operator or damage to the snow blower and other property.

Most injuries or property damage with snow blowers can be prevented if you follow all instructions in this manual and on the snow blower. The most common hazards are discussed below, along with the best way to protect yourself and others.

Avoid Rotating Impeller and Auger

Hand contact with the rotating impeller inside the discharge chute is the most common cause of injury associated with snow blowers. The snow blower auger can also cause serious injury. Keep away from the impeller and auger whenever the engine is running. If you need to work around the snow blower to clear snow for any reason, always shut off the engine. If the snow discharge chute becomes clogged, stop the engine and disconnect the spark plug cap. Use the snow clearing bar to remove the obstructions. Never put your hand into the snow discharge chute while the engine is running; serious personal injury could result.

Clear Operation Area

The snow blower can throw rocks and other objects with enough force to cause serious injury. Before operating the snow blower, carefully inspect the area and remove any visible stones, sticks, newspapers, pieces of wire, and other loose objects. Never use the snow blower to clear snow from a gravel road or driveway, as rocks may be picked up and ejected. They may cause injury to bystanders.

SNOW BLOWER SAFETY

Keep Shields in Place

Guards and shields are designed to protect you from being hit by thrown objects and to keep you from touching hot engine parts and moving components. For your safety and the safety of others, keep all shields in place when the engine is running.

Adjust the snow discharge chute to avoid hitting the operator, bystanders, windows, and other objects with ejected snow. Stay clear of the snow discharge chute while the engine is running.

Children and pets must be kept away from the area of operation to avoid injury from flying debris and contact with the snow blower.

Refuel with Care

Gasoline is extremely flammable, and gasoline vapor can explode. Allow the engine to cool if the snow blower has been in operation. Refuel only outdoors in a well-ventilated area with the engine OFF. Do not overfill the fuel tank. Never smoke near gasoline, and keep other flames and sparks away. Always store gasoline in an approved container. Make sure that any spilled fuel has been wiped up before starting the engine.

Turn Engine OFF When Not Operating the Snow Blower

If you need to leave the snow blower for any reason, even just to inspect the area ahead, always turn the engine off.

Operation on Slopes

To avoid overturning, be careful when changing the direction of the snow blower while operating it on a slope. Do not use the snow blower to remove snow from angled roof tops. The snow blower may overturn on steep slopes if left unattended, causing injury to the operator or bystanders.

Do not use the snow blower on a slope greater than 20 degrees.

Operating Conditions

Do not use the snow blower when visibility is poor. Under conditions of poor visibility, there is a greater risk of striking an obstacle or causing injury. Adjust the snow discharge chute to avoid hitting bystanders or vehicles.

Stay clear of the snow discharge chute while the engine is running and be aware that loose clothing can get drawn into the moving parts.

Operating Near Roads

Always watch for vehicle traffic when operating the snow blower near roads and driveways.

Operator Responsibility

Know how to stop the snow blower quickly in case of emergency. Understand the use of all snow blower controls.

Never permit anyone to operate the snow blower without proper instruction. Do not let children operate the snow blower. If people or pets suddenly appear in front of the snow blower while it is in operation, immediately release the auger and drive clutch levers to stop the snow blower and avoid possible injury from rotating auger blades.

While operating the snow blower, hold the handle firmly and walk, don't run. Wear suitable winter boots that resist slipping.

Wear safety glasses or eye shields during operation to protect eyes from thrown objects.

Exercise caution on slippery surfaces to avoid falling, especially when operating in reverse.

SNOW BLOWER SAFETY

SAFETY LABEL LOCATIONS

These labels warn you of potential hazards that can cause serious injury. Read them carefully.

If a label comes off or becomes hard to read, contact your Honda snow blower dealer for a replacement.

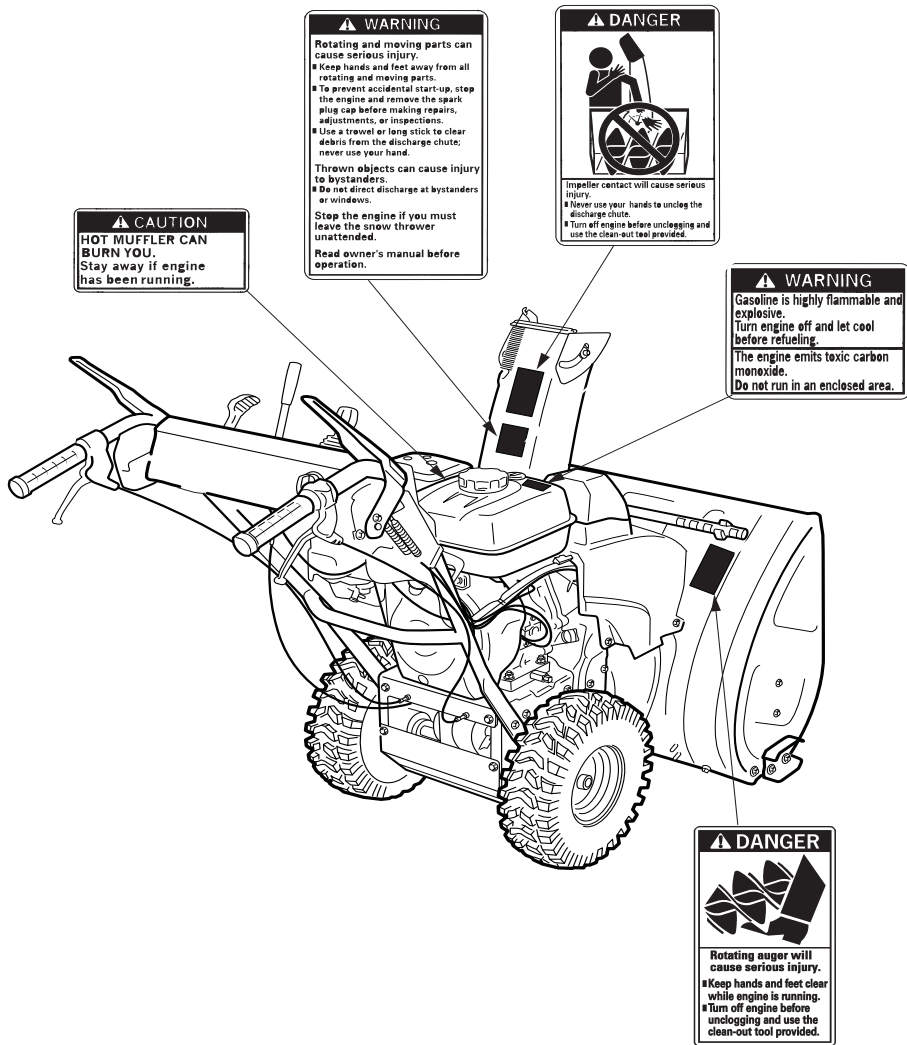

INITIAL USE INSTRUCTIONS

LIST OF LOOSE PARTS

Remove the loose parts carton and compare the loose parts against the following list. Contact an authorized Honda dealer from whom you purchased the snow blower if any of the loose parts shown are not included with your snow blower.

Ref No.	Description	Qty.
①	Tool kit (see page 41)	1
②	Bottle of oil (16 oz) HSS928A	2
	Bottle of oil (16 oz) HSS1332A	2
③	Skid shoes (AW, AWD) (see page 54)	2
④	Ignition key	2
⑤	Owner's manual	1

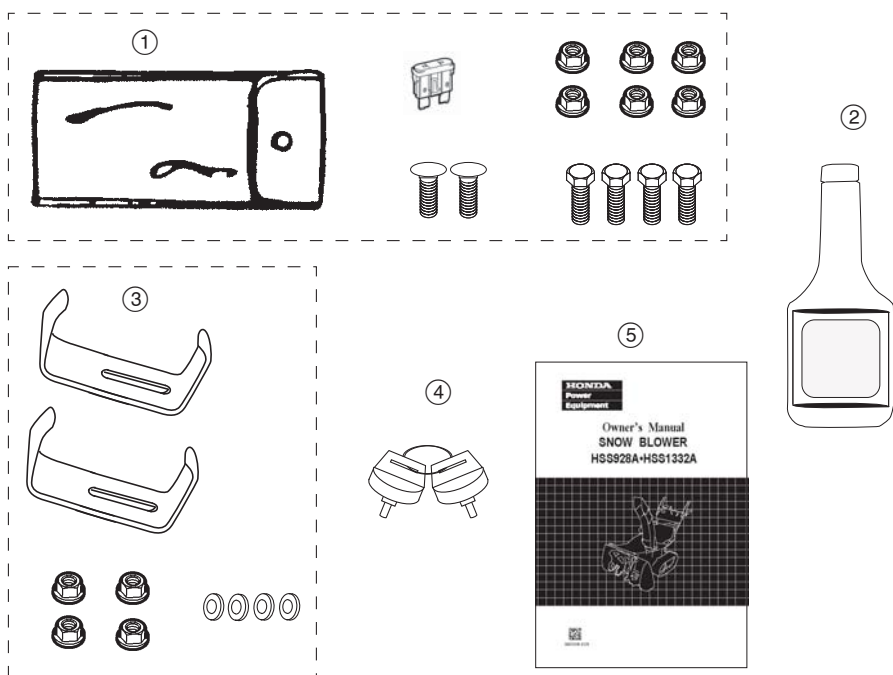

INITIAL USE INSTRUCTIONS

ADD ENGINE OIL

The snow blower is shipped **WITHOUT OIL** in the engine.

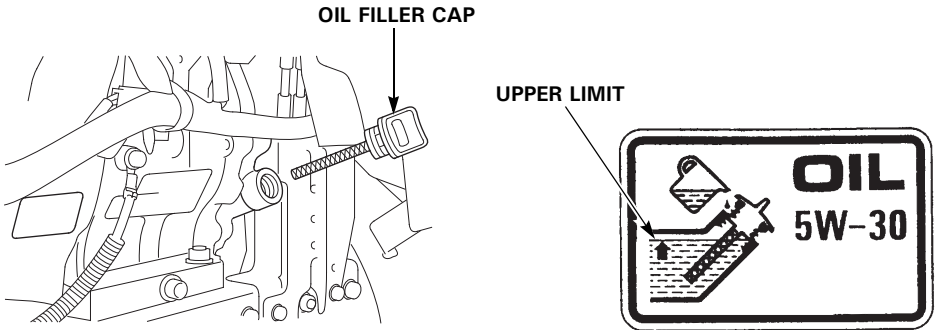

1. With the snow blower on a level surface, remove the oil filler cap/dipstick.
2. Add oil from the included bottle(s) of oil into the oil filler opening until it reaches the upper limit mark on the dipstick. Do not thread the dipstick in when checking the oil level.

All Honda engines are run at the factory prior to packaging. Most of the oil is removed prior to shipment; however, some oil remains in the engine. The amount of oil left in the engine varies.

3. If you don't use the supplied oil, add enough recommended oil (page 48) to bring the oil level to the upper mark on the dipstick. Do not thread the dipstick in when checking the oil level.
4. **Do not overfill the engine with oil.** After filling the engine with oil, screw the filler cap/dipstick in and remove the hang tag near the recoil starter grip that says "*The engine has no oil.*"

INITIAL USE INSTRUCTIONS

PLEASE REGISTER YOUR SNOW BLOWER

Please take a few minutes and register your purchase with Honda. You can register by:

- Completing and mailing the registration card included with your snow blower
- Going online to powerequipment.honda.com and click on Product Registration shown at the bottom of the page
- Scanning the QR code to the right and completing the online form



BEFORE USING YOUR SNOW BLOWER

All snow blower operators must read the following sections:

- **SNOW BLOWER SAFETY** (page 5)
- **BEFORE OPERATION** (page 25)
- **OPERATION** (page 28)
- **MAINTENANCE SCHEDULE** (page 42)

CONTROLS & FEATURES

COMPONENT & CONTROL LOCATIONS

Use the illustrations on these pages to locate and identify the most frequently used controls.

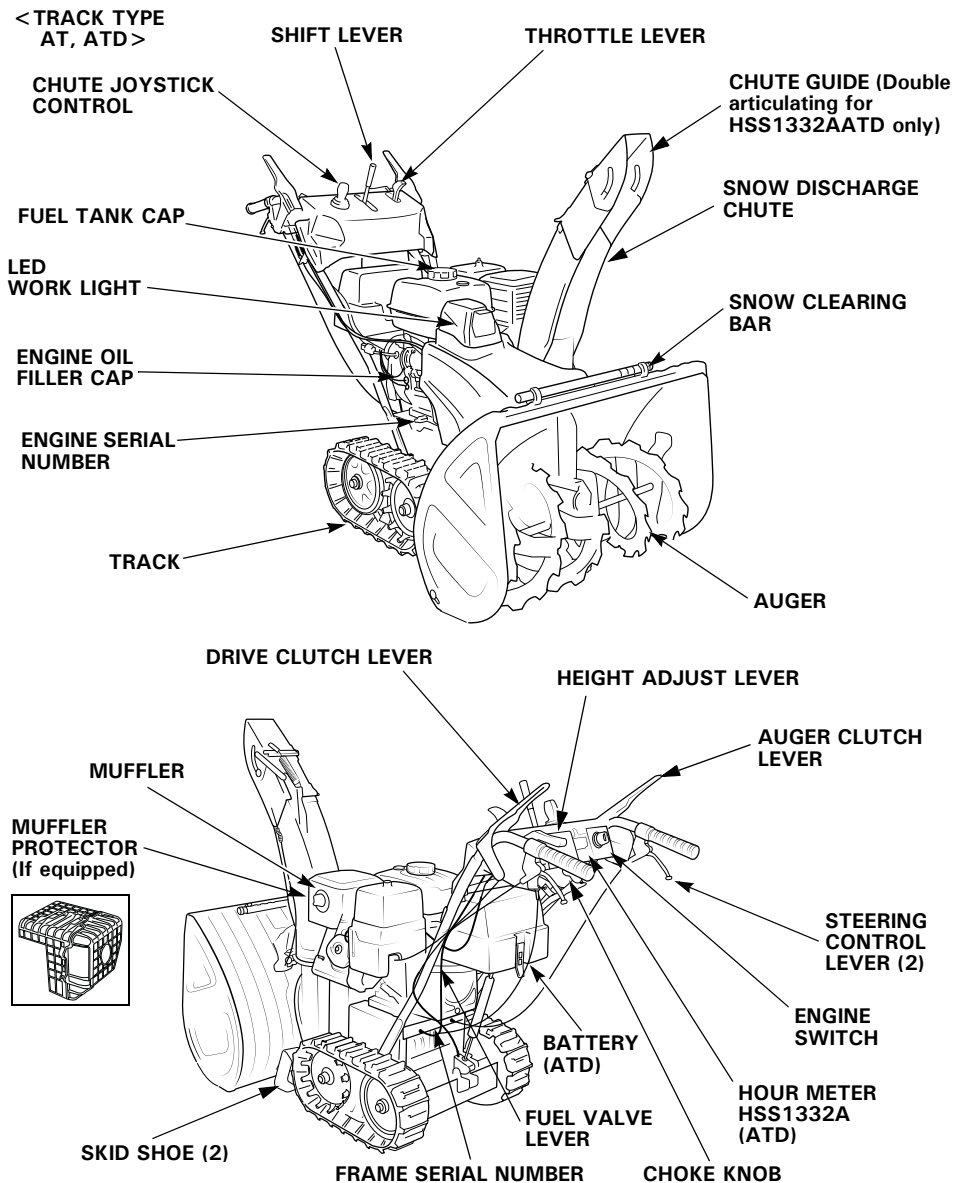

CONTROLS & FEATURES

< WHEEL TYPE: AW, AWD >

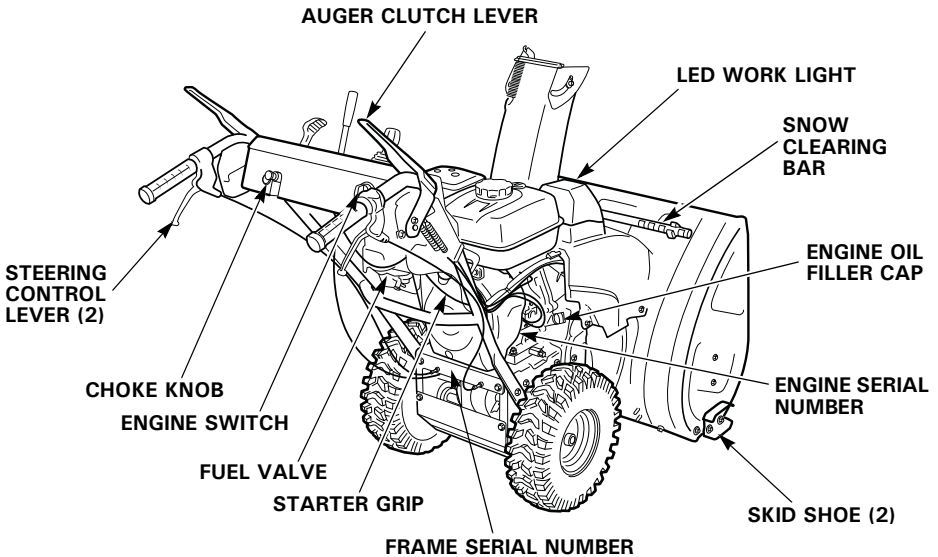
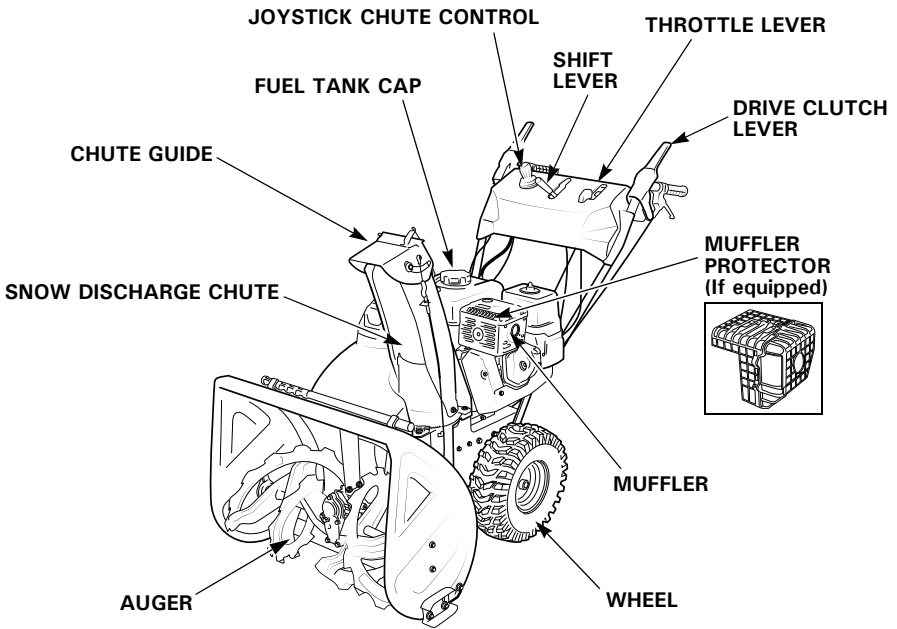

CONTROLS & FEATURES

CONTROLS

Engine Switch

The engine switch controls the ignition system. The key can only be inserted and removed when turned to OFF.

Recoil Starter (AT, AW)

OFF – Stops the engine.

ON – Running position, and for starting with the recoil starter.

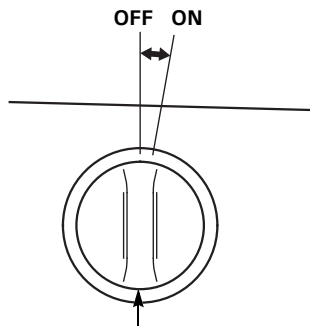

RECOIL ENGINE SWITCH

DC Electric Starter (ATD, AWD)

OFF – Stops the engine.

ON – Running position, and for starting with the recoil starter.

START - Use this position to start the engine with the DC electric starter. The switch returns to the ON position when you let go of the key.

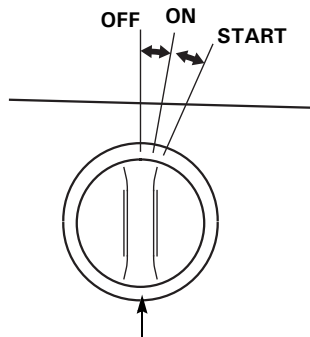

DC ELECTRIC ENGINE SWITCH

Auger-Lock Indicator (Electric Starter HSS1332A ATD)

OFF – The auger-lock indicator is off.

ON – The auger-lock indicator comes on.

START – After starting the auger-lock indicator goes off.

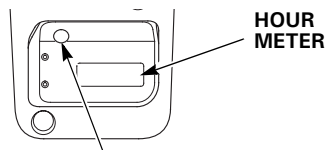

AUGER-LOCK INDICATOR

Hour Meter (HSS1332A ATD)

OFF – The accumulated engine running time indicator is OFF.

ON – The hour meter comes on, then the accumulated engine running time is shown.

START – After starting, the dot of the hour meter blinks and the engine running time is accumulated.

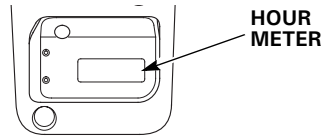

Fuel Valve Lever

The fuel valve opens and closes the fuel line leading from the fuel tank to the carburetor. Make sure that the fuel valve lever is positioned exactly at either the ON or OFF position. When the snow blower is not in use, always leave the fuel valve lever in the OFF position to reduce the possibility of fuel leakage.

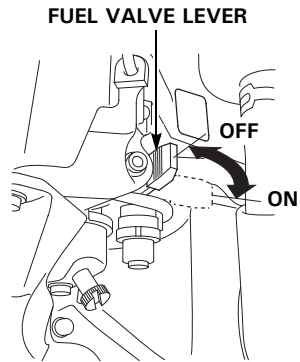

Fuel Gauge

The fuel gauge indicates the amount of fuel in the tank. When the fuel gauge needle enters the EMPTY position, refill the tank as soon as possible.

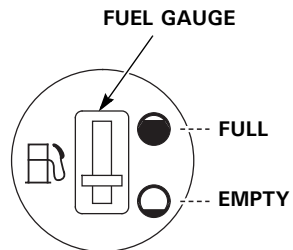

Starter Grip

Pull the starter grip to start the engine.
See page [29](#) for detailed starting procedures.

CONTROLS & FEATURES

Throttle Lever

The throttle lever controls engine speed from SLOW to FAST, and it will stay in any designated position.

NOTE: For best snow blowing performance, keep the throttle lever in the FAST position.

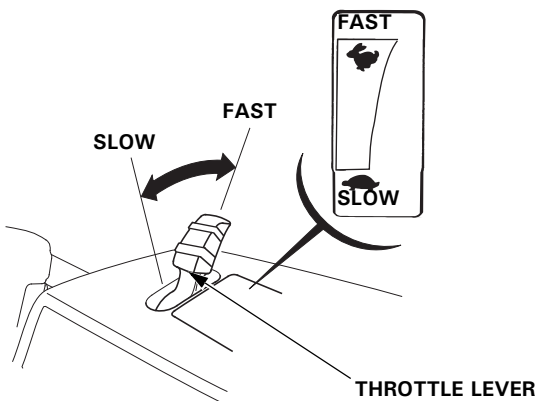

Choke Knob

The choke knob opens and closes the choke valve in the carburetor.

The CLOSED position enriches the fuel mixture for starting a cold engine.

The OPEN position provides the correct fuel mixture for operation after starting, and for restarting a warm engine.

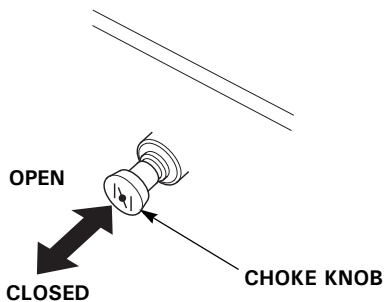

Shift Lever

Forward and reverse directions can be selected by shifting the shift lever. The lever will remain in any designated position. Actual movement of the snow blower takes affect when the drive clutch lever is engaged.

Set the lever in "N" (Neutral) when the snow blower is not in use and when starting.

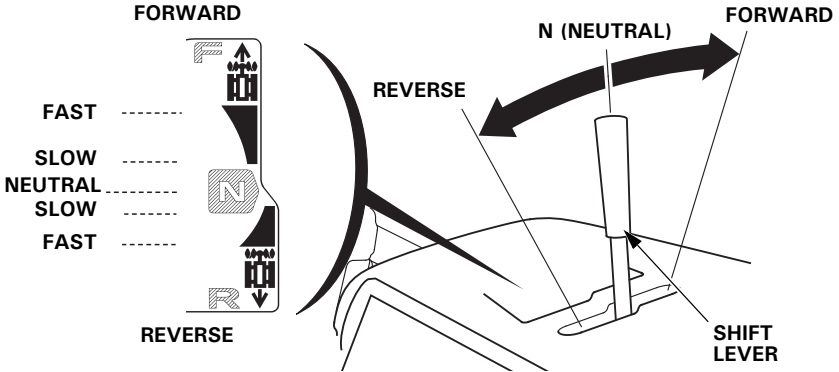

Chute Joystick Control

Use the chute joystick control to turn the snow discharge chute right or left and up or down.

The engine must be running to operate the chute joystick control. Chute movement speed will increase with engine speed. For maximum speed, move the throttle to the fastest position when using the chute joystick.

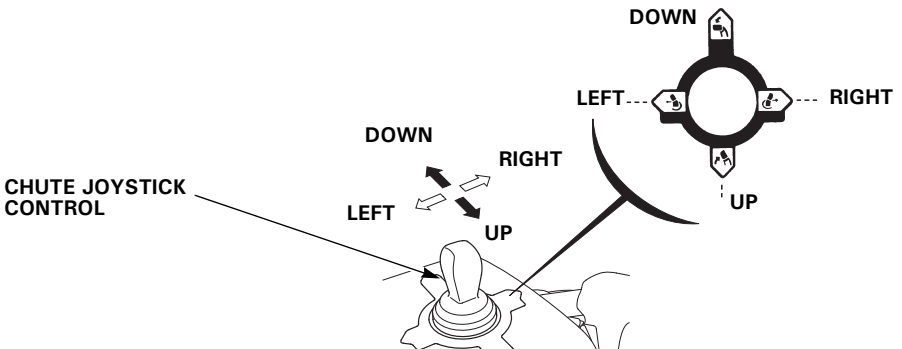

CONTROLS & FEATURES

Drive Clutch Lever

Depress the drive clutch lever to move the snow blower forward or backward based on the position of the shift lever (see previous page). When transporting the snow blower, depress the drive clutch lever without the auger clutch lever.

DRIVE CLUTCH
LEVER

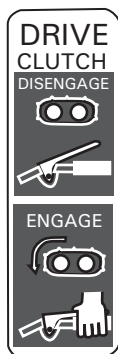
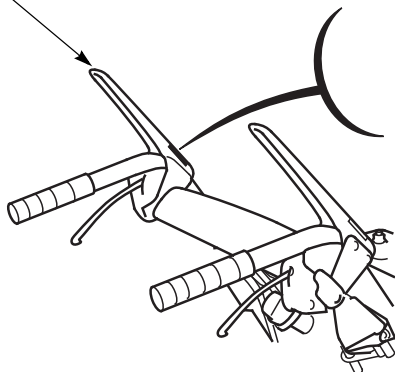

Auger Clutch Lever

Depress the auger clutch lever to start the snow blowing mechanism. If the drive clutch lever is engaged, the auger clutch lever will lock engaged when it is depressed. However, the auger clutch lever will unlock when the drive clutch lever is released.

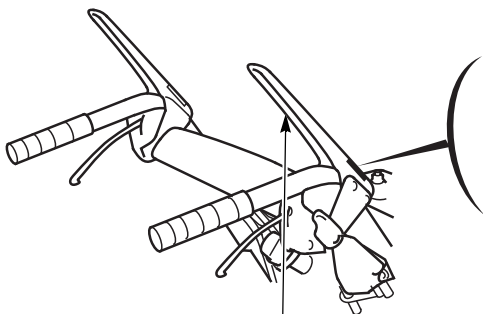

AUGER CLUTCH LEVER



CONTROLS & FEATURES

When both levers are depressed, the drive clutch lever locks the auger clutch lever down. Releasing the drive clutch lever then unlocks and releases the auger clutch lever.

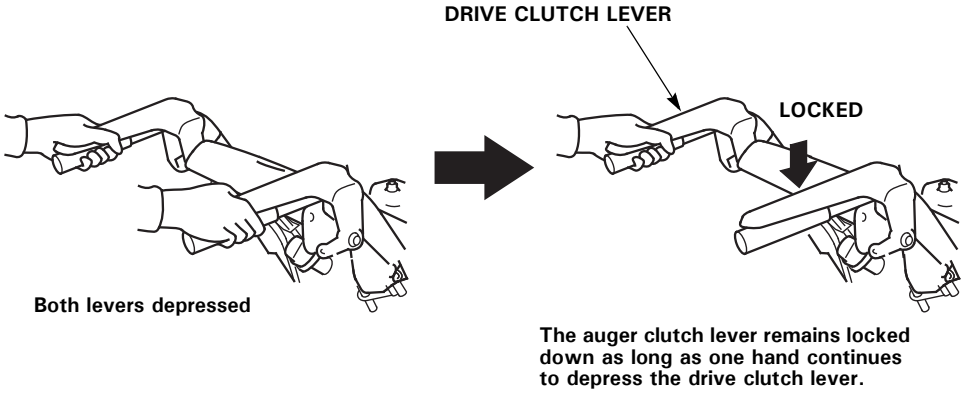

Steering Control Levers

The steering control levers are located under the handlebar grips. With both steering control levers released, the snow blower will advance in a straight line in either a forward or reverse direction depending on the position of the shift lever.

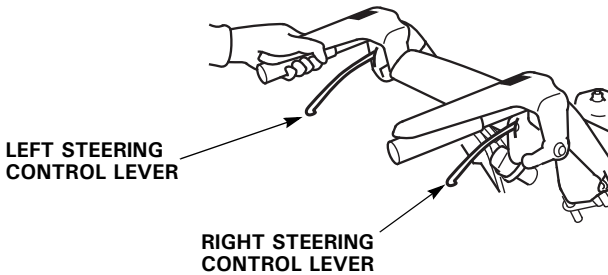

CONTROLS & FEATURES

Pull the left steering control lever against the handlebar to turn the snow blower to the left.

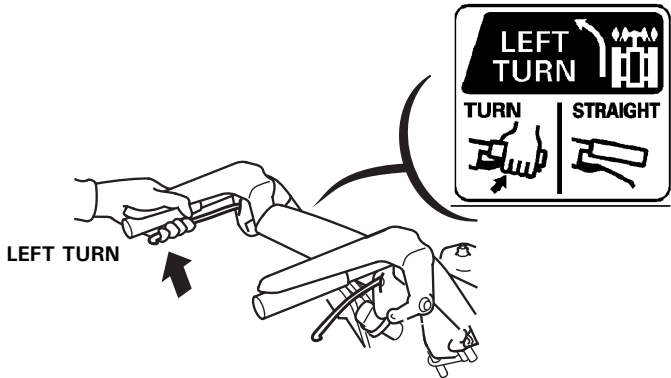

Pull the right steering control lever against the handlebar to turn the snow blower to the right.

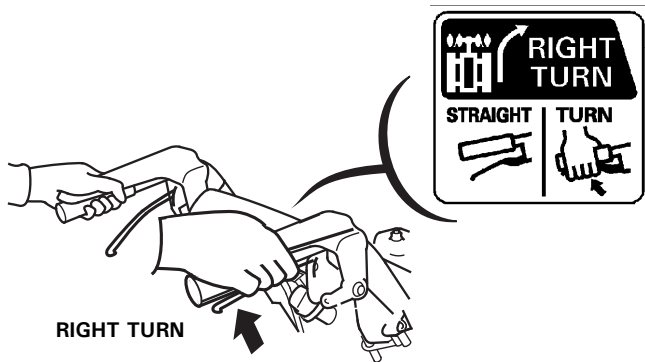

Do not partially engage or release the steering control levers. Always fully engage or fully release the levers.

Pull both steering control levers at the same time to momentarily disengage the transmission. With the transmission disengaged, the snow blower is free to maneuver (push or pull) by hand with or without the engine running.

Note: Engaging the steering control levers only stops power transmission to the track or wheel; it does not apply a brake. Under high traction conditions, such as on asphalt or concrete, steering movement will be subtle and may require additional force be applied by the user to turn the snow blower.

Height Adjust Lever (track models AT, ATD)

Use the infinitely variable height adjust lever to change the height of the auger housing.

1. Hold the handlebar with both hands and depress the lever with your left thumb.
2. Move the handle up or down as needed to obtain the desired auger height position.
3. Release the lever to lock the height of the auger in position.
 - LOWER: Hard snow or fine finish
 - MIDDLE: Normal use
 - HIGHER: Deep snow or for transporting the snow thrower.

If the handlebar is lifted while depressing the height adjust lever, the auger can contact the ground. This may be desirable under certain conditions to achieve maximum snow removal from the surface; however, be sure the surface is very smooth and ice covered. Otherwise, the auger teeth may become damaged. Under most conditions use the middle position by simply depressing the lever and allowing the auger to rest on the ground, without lifting the handlebars.

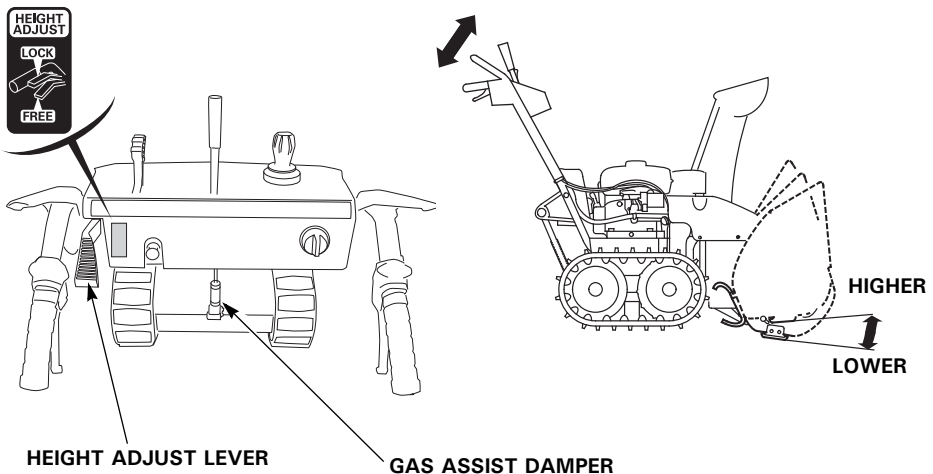

NOTICE

Do not pull on the gas assisted damper or tie it with a rope, or it may cause a functional damage of the assembly.

CONTROLS & FEATURES

FEATURES

LED Work Light

The LED work light comes ON while the engine is running, and it goes OFF when the engine stops. The light does not come ON when the engine switch is turned ON unless the engine is started.

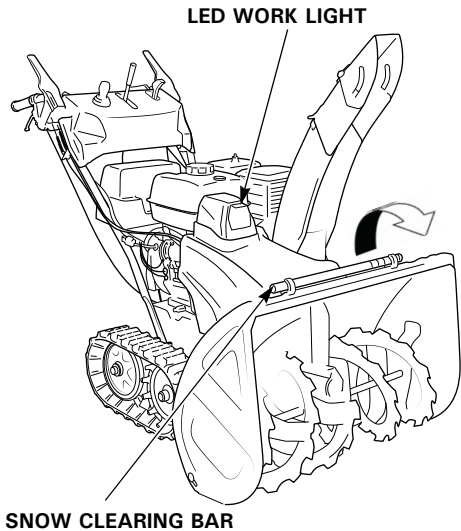

Snow Clearing Bar

If the snow discharge chute or snow blowing mechanism becomes restricted, stop the engine and make sure all rotating parts have come to a complete stop. Remove the spark plug cap from the spark plug.

Use the snow clearing bar to remove the obstruction.

⚠ WARNING

An obstructed auger or blower could suddenly move when the obstruction is cleared.

Sudden auger or blower movement could cause severe injury if your hands are being used to clear the area.

Never clear the discharge chute or auger area with your hands, and always stop the engine, remove the spark plug cap, and clear obstructions with the clearing bar.

After clearing the obstruction, wipe the bar clean and store it in the holders. Replace the spark plug cap.

Hour Meter HSS1332A (ATD only)

The hour meter shows the accumulated engine running time of the snow blower. Use it as a guide for inspection or maintenance.

When the engine switch is turned to the "ON" position, the total accumulated engine running time is shown.

After starting the engine, the dot blinks and the engine running time starts to accumulate.

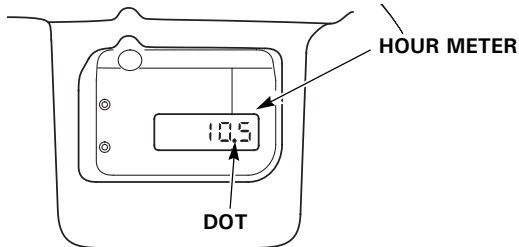

Five digits are provided to show running time (to 9,999.9 hours), and the right end digit displays tenths of an hour (0.1 = 6 minutes).

The engine running time indication goes off when the engine stops for more than 5 minutes with the engine switch positioned in the "ON" position. The running time indication comes on again when restarting the engine.

NOTE:

The battery will discharge if the engine switch is in the "ON" position without the engine running.

CONTROLS & FEATURES

Auger-Lock Indicator HSS1332A (ATD only)

The auger-lock indicator comes on when the engine switch is turned to the "ON" position, then goes off after starting the engine.

To prevent damage to the auger and/or auger transmission, the snow blower stops the engine and blinks the red auger-lock indicator under following conditions:

- A foreign object (for example: stone) is lodged in the rotating auger.
- The auger contacts a curb.
- The auger is forcibly thrust into hard-packed snow.

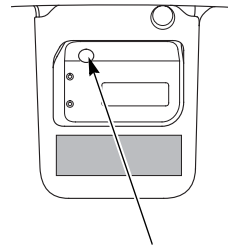

AUGER-LOCK INDICATOR

To remove a foreign object, follow the instructions shown on page 38.

When the engine stops due to overload or lack of fuel, the auger-lock indicator comes on. In this case, remove the obstruction or fill the fuel tank with gasoline before restarting the engine.

To prevent accidental starting while removing a foreign object from the auger, turn the engine switch to the "OFF" position and disconnect the spark plug cap.

Make sure that all rotating parts are stopped completely before removing a foreign object.

BEFORE OPERATION

ARE YOU READY TO GET STARTED?

Your safety is your responsibility. A little time spent in preparation will significantly reduce the risk of injury.

Knowledge

Read and understand this manual. Know what the controls do and how to operate them.

Familiarize yourself with the snow blower and its operation before you begin using it. Know how to quickly shut off the snow blower in case of an emergency.

IS YOUR SNOW BLOWER READY TO GO?

For your safety, and to maximize the service life of your equipment, it is very important to take a few moments before you operate the snow blower to check its condition. Be sure to take care of any problem you find, or have your servicing dealer correct it, before you operate the snow blower.

WARNING

Improperly maintaining this snow blower, or failing to correct a problem before operation, could cause a significant malfunction.

Some malfunctions can seriously hurt or kill you.

Always perform a pre-operation inspection before each operation, and correct any problem.

Before beginning your pre-operation checks, be sure the snow blower is on a level surface and the engine switch is in the OFF position.

BEFORE OPERATION

Check the General Condition of the Snow Blower:

- Before each use, look around and underneath the snow blower for signs of oil or gasoline leaks.
- Check the auger housing and the discharge chute for accumulation of packed snow or ice. Clean the auger housing and discharge chute before starting the snow blower.
- Look for signs of damage.
- Check each control for proper operation.
- Check the auger and blower for loose or broken bolts. If broken, replace them with new ones.
- Check the skid shoes and scraper for wear. Replace them if necessary (see page [54](#)).
- Check that all nuts, bolts, and screws are tightened.

Check the Engine

- Check the oil level (see page [46](#)).
- Check the fuel level (see page [44](#)). Starting with a full tank will help to eliminate or reduce operating interruptions for refueling.

CHECK YOUR WORK AREA

For your safety and the safety of others, always inspect the area before operating the snow blower.

Objects

Anything that can be picked up by the auger and thrown is a potential hazard to you and others. Thoroughly inspect the area where the equipment is to be used and remove all doormats, newspapers, sleds, boards, wires, stones, and nails from the work area.

People and Pets

People and animals near the work area can move into your snow blower's path or into a position where they could be struck by thrown objects. Clear the area of people, especially children, and pets. Their safety is your responsibility.

Work Area

Check the condition of the snow. Adjust your snow blower ground speed (not engine speed) and snow blowing swath accordingly.

Check the skid shoes for proper adjustment. Adjust the skid shoes to obtain the proper auger ground clearance for the surface on which you are operating (see page [54](#)).

OPERATION

SNOW BLOWING PRECAUTIONS

Before operating the snow blower for the first time, please review both the *SNOW BLOWER SAFETY* chapter (see page 5) and the *BEFORE OPERATION* chapter (see page 25).

Even if you have operated other snow blowers, take time to become familiar with how this snow blower works, and practice in a safe area until you build up your skills.

Never tamper with or alter any of the controls or safety devices on the snow blower. Tampering is a violation of federal and California law.

For your safety, do not start or operate the engine in an enclosed area such as a garage. Your snow blower's exhaust contains poisonous carbon monoxide gas that can collect rapidly in an enclosed area and cause illness or death.

WARNING

Exhaust contains poisonous carbon monoxide gas that can build up to dangerous levels in closed areas.

Breathing carbon monoxide can cause unconsciousness or death.

Never run the engine in a closed, or even partly closed area where people may be present.

STARTING THE ENGINE

1. Move the shift lever to "N" (Neutral) position.

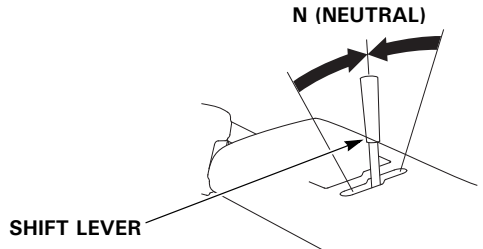

2. Be sure that the drain knob is tightened securely. Turn the fuel valve to the ON position.

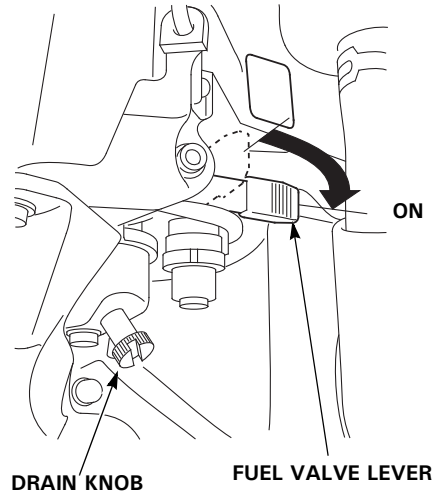

3. In cold weather or when the engine is cold, pull the choke knob to the CLOSED position and move the throttle lever to the FAST position.

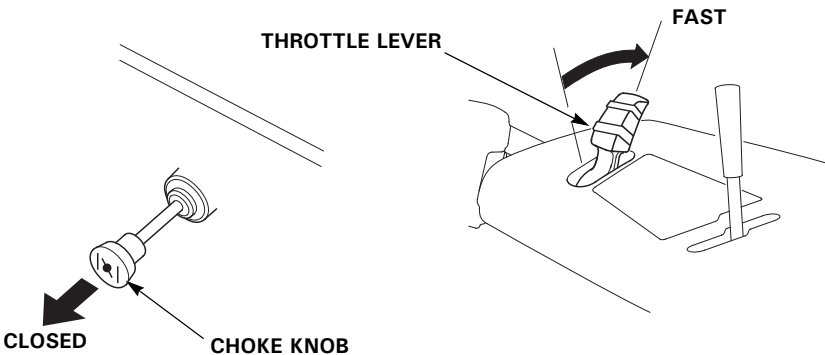

4. Start the engine.

OPERATION

Electric-start Models (ATD, AWD type)

Turn the engine switch to the START position and release the switch after the engine has started. The switch automatically returns to the ON position.

NOTICE

Do not operate the starter for more than one minute. If the engine fails to start, release the button and allow the starter to cool for 15 minutes before operating it again.

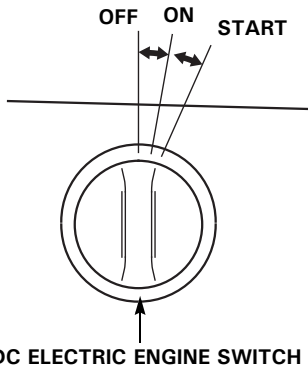

Manual Starting only

- Turn the engine switch to the ON position.
- Pull the starter grip lightly until you feel resistance, then pull briskly in the direction of the arrow as shown.
- Return the starter grip gently to the engine.

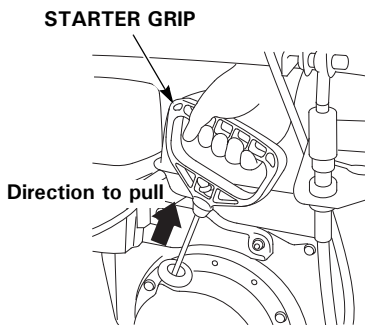

NOTICE

Do not allow the starter grip to snap back against the engine. Return it gently to prevent damage to the starter.

Do not pull the starter grip while the engine is running. The starter could be damaged.

5. Let the engine warm up for several minutes.

If the choke knob has been pulled to the CLOSED position to start the engine, gradually push it to the OPEN position as the engine warms up. Move the throttle lever to the SLOW position.

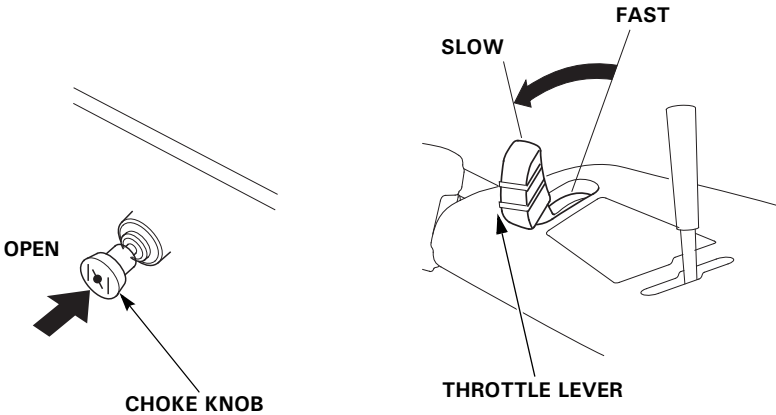

6. While warming the engine up, also warm the transmission as follows:

a. Check that the shift lever is in the "N" (Neutral) position.

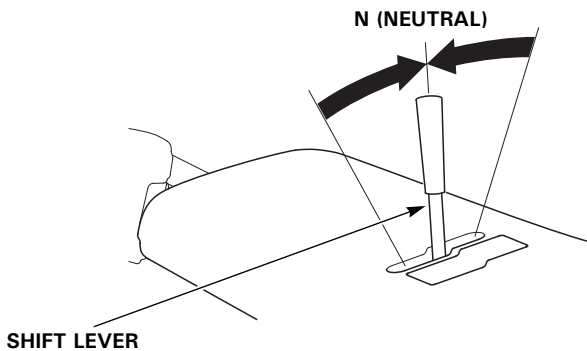

OPERATION

- b. Squeeze the drive clutch lever for about 30 seconds to warm up the transmission fluid.

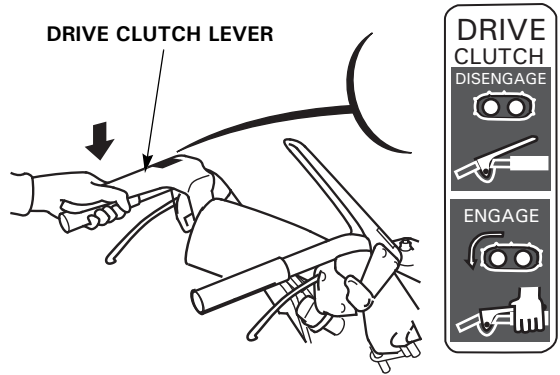

STOPPING THE ENGINE

To stop the engine in an emergency, simply turn the engine switch to the OFF position.

Under normal conditions, use the following procedure.

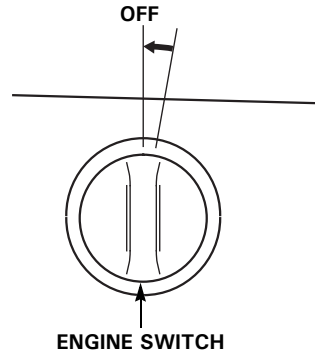

1. Release the auger and drive clutch levers. The drive and snow blowing mechanism will stop operation.

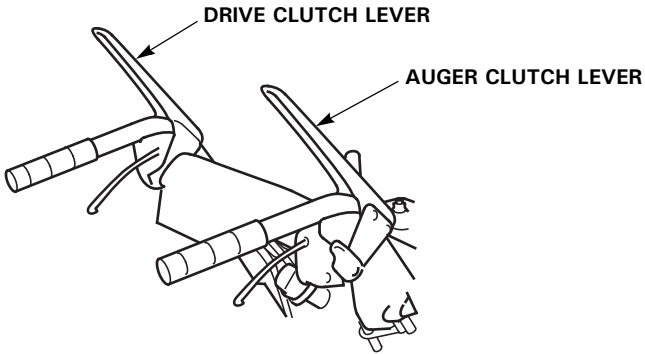

2. Move the shift lever to "N" (Neutral) position.

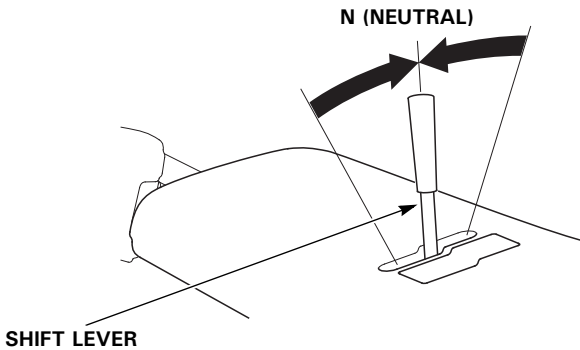

3. Turn the throttle lever to the SLOW position.

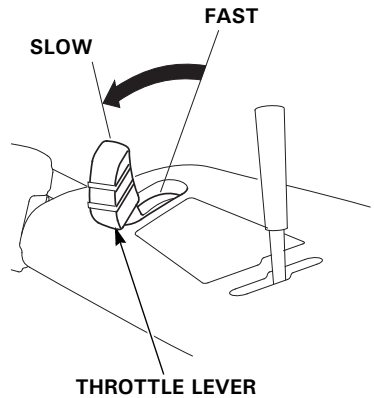

OPERATION

4. Turn the engine switch to the OFF position.

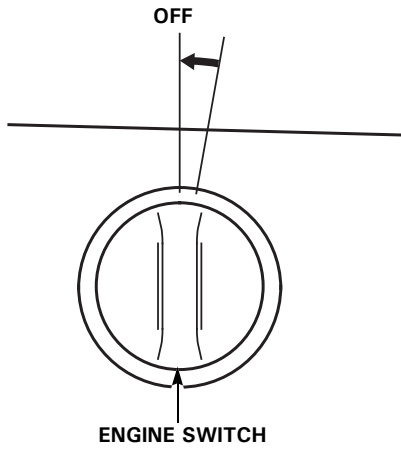

5. Turn the fuel valve lever to the OFF position.

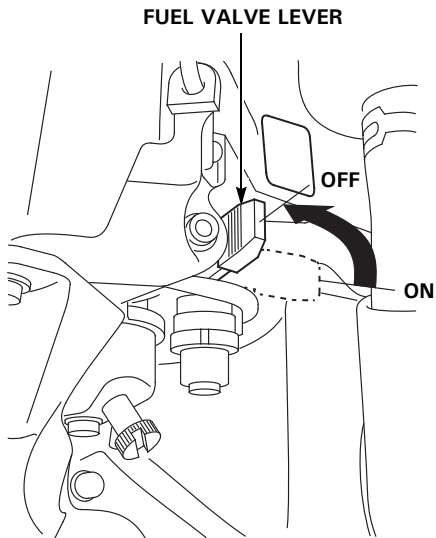

CLEARING SNOW

1. Move the throttle lever to the FAST position for normal operation.

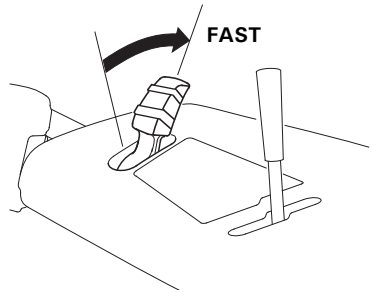

2. Release the auger clutch lever, and move the shift lever to select the desired drive speed.

Slower speed is recommended for removing deep or hard-packed snow.

Faster speed is recommended for heavy wet snow conditions.

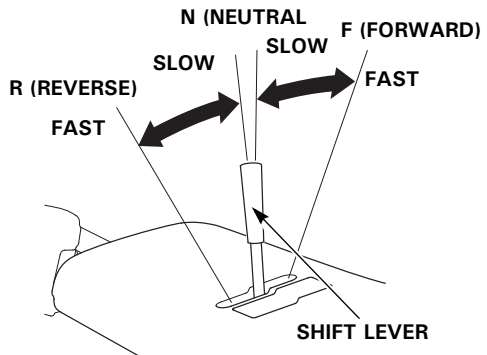

3. AT, ATD only: Set the auger height to the desired position (see page 21).

4. Adjust the throwing direction by using the chute joystick control (see page 17).

5. Depress the auger clutch lever. The auger will rotate and the machine will clear snow when you depress the auger clutch lever.

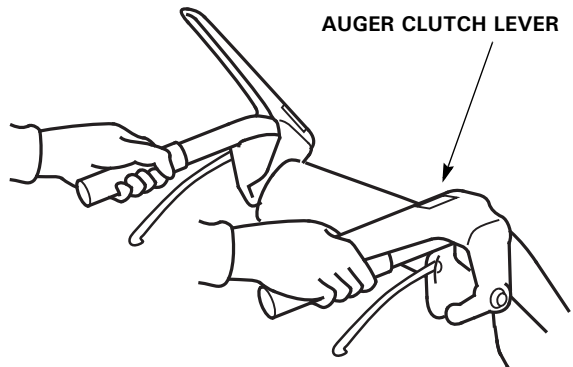

OPERATION

6. Depress the drive clutch lever to self-propel the snow blower.

If the transmission shift lever (see page 35) is in the "F" (FORWARD) position, the hydrostatic drive will propel the snow blower forward when you squeeze the drive clutch lever.

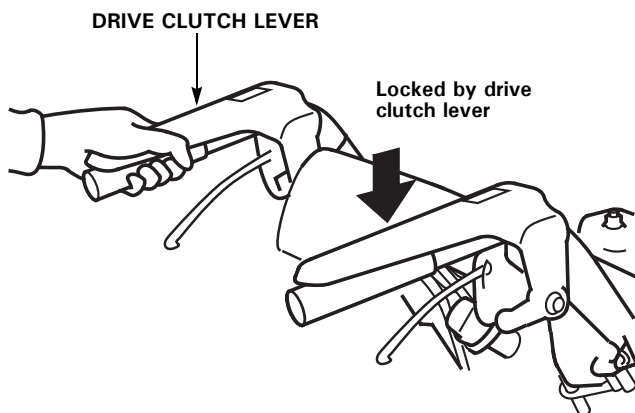

When both levers are depressed, the drive clutch lever locks the auger clutch lever down. This frees your right hand to operate the other snow blower controls. Releasing the drive clutch lever unlocks and releases the auger clutch lever.

To move from one place to another or to change direction, use the drive clutch lever only. Release both the drive clutch lever and auger clutch lever, and then depress the drive clutch lever.

7. Release both clutch levers to stop clearing and moving.

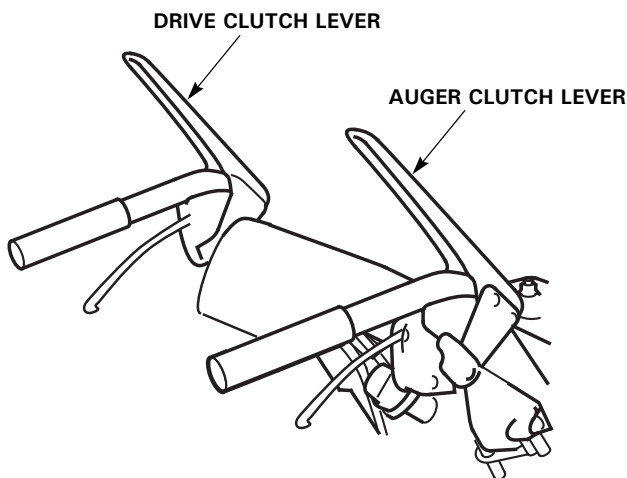

SNOW-CLEARING TIPS

For best efficiency, clear snow before it hardens and turns to ice. Do not reduce engine speed while clearing snow.

Operating tips for clearing hard or deep snow:

- Reduce forward speed. If that is not sufficient, use the shift lever to clear snow with a back and forth motion.
- Clear a narrower swath. Make several passes with the auger overlapping the cleared areas.
- If the snow is deeper than the height of the auger, remove it in several steps, as shown below, or install the drift-breaker kit (optional part) that is available from your authorized Honda snow blower dealer.

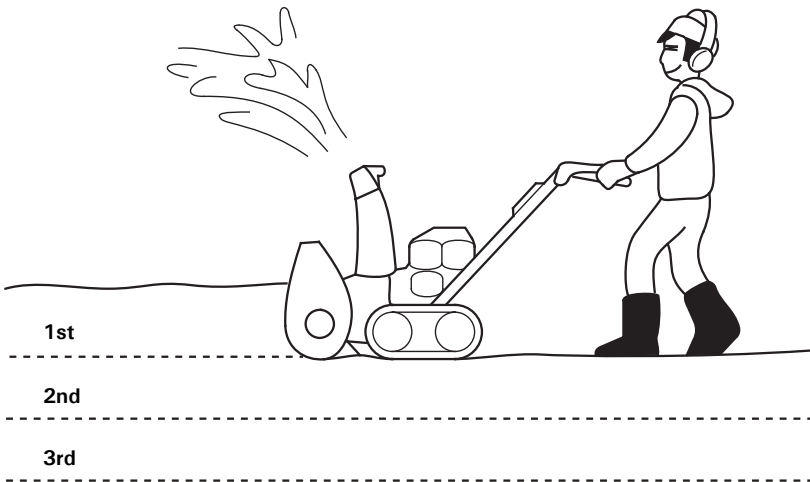

OPERATION

REMOVING OBSTRUCTIONS

If the snow discharge chute or snow blowing mechanism becomes restricted, review snow clearing tips (see page 37) to reduce the possibility of reoccurring obstructions.

1. Before removing the obstruction, be sure to stop the engine and ensure all rotating parts have come to a complete stop. Remove the spark plug cap from the spark plug (see page 49).
2. Remove the snow clearing bar to clear the obstruction.

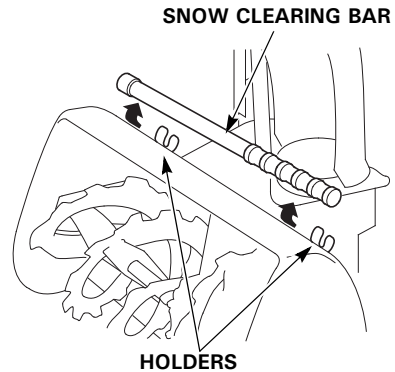

⚠ WARNING

An obstructed auger or blower could suddenly move when the obstruction is cleared.

Sudden auger or blower movement could cause severe injury if your hands are being used to clear the area.

Never clear the discharge chute or auger area with your hands, and always stop the engine, remove the spark plug cap, and clear obstructions with the clearing bar.

3. After unclogging, wipe the bar clean, and secure it in the holders.
4. Reinstall the spark plug cap on the spark plug.

SERVICING YOUR SNOW BLOWER

THE IMPORTANCE OF MAINTENANCE

Good maintenance is essential for safe, economical, and trouble-free operation. It will also help reduce air pollution.

To help you properly care for your snow blower, the following pages include a maintenance schedule, routine inspection procedures, and simple maintenance procedures using basic hand tools. Other service tasks that are more difficult, or require special tools, are best handled by professionals and are normally performed by a Honda technician or other qualified mechanic.

The maintenance schedule applies to normal operating conditions. If you operate your snow blower under unusual conditions, consult your servicing dealer for recommendations applicable to your individual needs and use.

Remember that your authorized Honda servicing dealer knows your snow blower best and is fully equipped to maintain and repair it.

WARNING

Improper maintenance, or failure to correct a problem before operation, can cause a malfunction.

Some malfunctions can seriously hurt or kill you.

Always follow the inspection and maintenance recommendations and schedules in this owner's manual.

To ensure the best quality and reliability, use only new Honda Genuine parts or their equivalents for repair or replacement.

Maintenance, replacement, or repair of the emission control devices and systems may be performed by any engine repair establishment or individual, using parts that are "certified" to EPA standards.

SERVICING YOUR SNOW BLOWER

MAINTENANCE SAFETY

Some of the most important safety precautions follow. However, we cannot warn you of every conceivable hazard that can arise in performing maintenance. Only you can decide whether or not you should perform a given task.

WARNING

Improper maintenance can cause an unsafe condition.

Failure to properly follow maintenance instructions and precautions can cause you to be seriously hurt or killed.

Always follow the procedures and precautions in this manual.

Safety Precautions

- Make sure the engine is off before you begin any maintenance or repairs. This will eliminate several potential hazards:
 - **Carbon monoxide poisoning from engine exhaust**
Operate outside, away from open windows or doors.
 - **Burns from hot parts**
Let the engine and exhaust system cool before touching.
 - **Injury from moving parts**
Do not run the engine unless instructed to do so.
- Read the instructions before you begin, and make sure you have the tools and skills required.
- To reduce the possibility of fire or explosion, be careful when working around gasoline. Use only a nonflammable solvent, not gasoline, to clean parts. Keep cigarettes, sparks, and flames away from all fuel-related parts.

SERVICING YOUR SNOW BLOWER

TOOL KIT

The tools necessary for performing some of the periodic maintenance, simple adjustments, and repairs are supplied in the tool kit.

Spare shear bolts and nuts are also included in the tool kit.

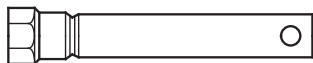

SPARK PLUG WRENCH



6 mm SELF
LOCK
NUTS (6)



WRENCH HANDLE



SHEAR
BOLTS (4)

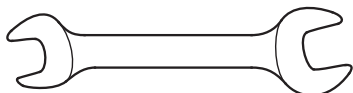

14 × 17 mm
WRENCH



SHEAR
BOLTS (2)

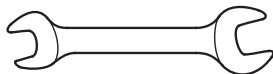

10 × 12 mm
WRENCH



FUSE 5 A
(ATD, AWD)

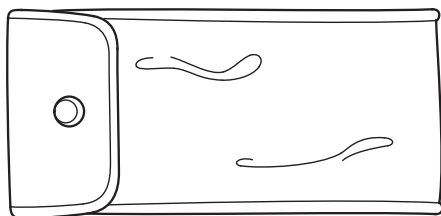

TOOL BAG

SERVICING YOUR SNOW BLOWER

MAINTENANCE SCHEDULE

REGULAR SERVICE PERIOD (1) Perform at every indicated month or operating hour interval, whichever comes first. Item		Each use	Every year		First month or 20 hours	Every 100 hours	Every 300 hours	Every 4 years	Page
			Before operation	Before storage					
Engine oil	Check level	o							46
	Change		o (4)		o	o (4)			47
Auger transmission oil	Check level		o (2)						—
Spark plug	Check-adjust		o (4)						49
	Replace					o	o		
Auger skid shoes and scraper	Check-adjust	o	o (4)						54
Track	Check-adjust		o (4)		o				51
Wheel	Check - condition and tire pressure	o		o					52
Auger and blower shear bolts	Check	o							52
Bolts, nuts, fasteners	Check	o							26
Fuel sediment cup	Clean			o					59
Fuel tank and carburetor	Drain			o					59

- (1) For professional commercial use, log hours of operation to determine proper maintenance intervals.
- (2) These items should be serviced by your Honda servicing dealer, unless you have the proper tools and are mechanically proficient. Refer to the Honda Shop Manual for service procedures. See "Honda Publications" on page 77 for ordering information.
- (3) Check the belt for wear or damage. Replace the belt with a new one if it is worn or damaged.
- (4) These parts may require more frequent inspection and replacement under heavy use.

Failure to follow this maintenance schedule could result in non-warrantable failures.

SERVICING YOUR SNOW BLOWER

REGULAR SERVICE PERIOD (1) Perform at every indicated month or operating hour interval, whichever comes first. Item		Each use	Every year		First month or 20 hours	Every 100 hours	Every 300 hours	Every 4 years	Page
			Before operation	Before storage					
Lubrication points	Apply grease/lube			o					56
Drive chains (track models)	Lubricate			o					56
Chute guide control cable	Check-adjust		o (2) (4)		o (2) (4)				—
Auger clutch cable	Check-adjust		o (2) (4)		o (2) (4)				—
Throttle/Choke cable	Check-adjust		o (2) (4)						—
Drive clutch cable	Check-adjust		o (2) (4)		o (2) (4)				—
Height adjust lever	Check movement		o (2) (4)						
Drive belt	Check-adjust		o (2) (3) (4)		o(2)(3)(4)				—
Auger belt	Check-adjust		o (2) (3) (4)		o(2)(3)(4)				—
Idle speed	Check-adjust		o (2)				o (2)		—
Valve clearance	Check-adjust		o (2)				o (2)		—
Combustion chamber	Clean	After every 1,000 hours (2)							—
Fuel tank and filter	Clean					o (2)		o (2)	—
Fuel tube	Check	Every 2 years (2)							—
	Replace							o (2)	
Battery (if equipped)	Check voltage	Charge if voltage is less than 12.9 V.							60
	Charge		o	o					

- (1) For professional commercial use, log hours of operation to determine proper maintenance intervals.
- (2) These items should be serviced by your Honda servicing dealer, unless you have the proper tools and are mechanically proficient. Refer to the Honda Shop Manual for service procedures. See "Honda Publications" on page 77 for ordering information.
- (3) Check the belt for wear or damage. Replace the belt with a new one if it is worn or damaged.
- (4) These parts may require more frequent inspection and replacement under heavy use.

Failure to follow this maintenance schedule could result in non-warrantable failures.

SERVICING YOUR SNOW BLOWER

REFUELING

With the engine stopped, remove the fuel tank cap and check the fuel level. Refill the tank if the fuel level is low. Do not fill above the base of the filler neck.

⚠ WARNING

Gasoline is highly flammable and explosive. You can be burned or seriously injured when handling fuel.

- Keep heat, sparks, and flame away
- Stop the engine and let it cool before refueling
- Refuel only outdoors
- Wipe up spills immediately

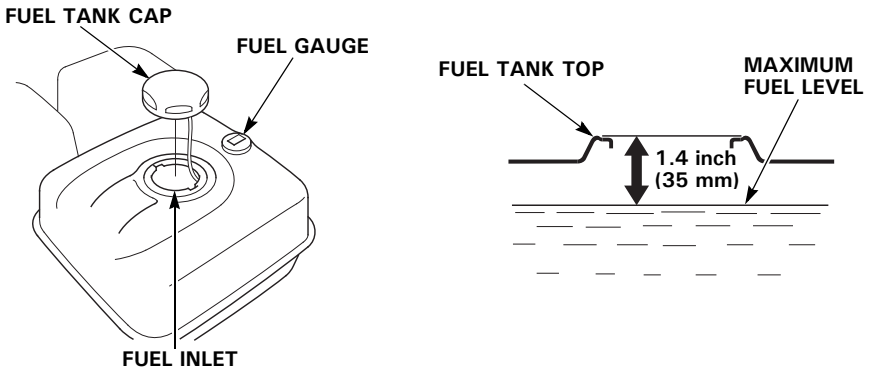

Refuel in a well-ventilated area before starting the engine. If the engine has been running, allow it to cool. Refuel carefully to avoid spilling fuel. Add fuel only while standing on the fuel tank side of the snow blower. Do not fill the fuel tank completely. Fill tank to approximately 1.4 inch (35 mm) below the top of the fuel tank to allow for fuel expansion. After refueling, tighten the fuel tank cap securely.

SERVICING YOUR SNOW BLOWER

Never refuel the snow blower inside a building where gasoline fumes may reach flames or sparks. Keep gasoline away from appliance pilot lights, barbecues, electric appliances, and power tools.

Spilled fuel is not only a fire hazard, it causes environmental damage. Wipe up spills immediately.

NOTICE

Fuel can damage paint and plastic. Be careful not to spill fuel when filling your fuel tank. Damage caused by spilled fuel is not covered under warranty.

FUEL RECOMMENDATIONS

The snow blower engine is certified to operate on unleaded gasoline with a pump octane rating of 86 or higher.

You may use regular unleaded gasoline containing no more than 10% ethanol (E10) or 5% methanol by volume. In addition, methanol must contain cosolvents and corrosion inhibitors.

Use of fuels with content of ethanol or methanol greater than stated above may cause starting and/or performance problems. It may also damage metal, rubber, and plastic parts of the fuel system.

Engine damage or performance problems that result from using a fuel with percentages of ethanol or methanol greater than stated above are not covered under the *Distributor's Limited Warranty*.

Never use stale or contaminated gasoline or an oil and gasoline mixture. Avoid getting dirt or water in the fuel tank.

If your equipment will be used on an infrequent basis, please refer to the fuel section of the STORAGE chapter (see page 57) for additional information regarding fuel deterioration.

SERVICING YOUR SNOW BLOWER

ENGINE OIL LEVEL CHECK

Check the engine oil level with the engine stopped and in a level position.

1. Remove the oil filler cap.
2. Check the oil level. Do not thread the dipstick in when checking the oil level. If it is below the upper limit on the dipstick, fill with the recommended oil to the upper limit on the dipstick (see page 48).
3. Reinstall the oil filler cap securely.

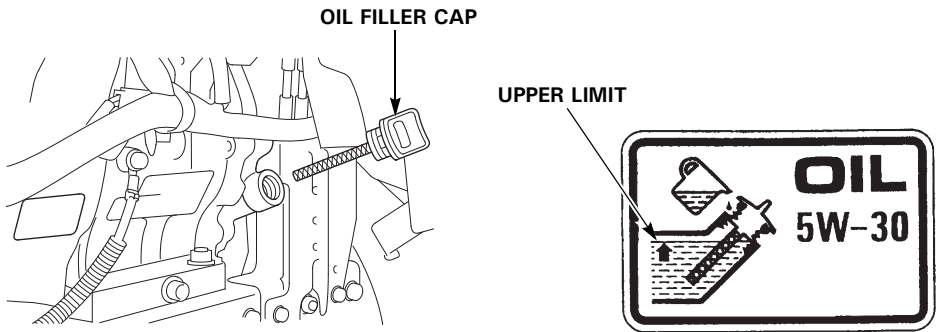

NOTICE

Running the engine with a low oil level can cause engine damage. This type of damage is not covered by the Distributor's Limited Warranty.

SERVICING YOUR SNOW BLOWER

ENGINE OIL CHANGE

Drain the oil while the engine is still warm to assure rapid and complete draining.

1. Place the snow blower on a level surface.
2. Place a suitable container below the engine to catch the used oil, then remove the oil filler cap and the drain plug.

To avoid loosening the drain plug extension, hold it with a 17 mm wrench while loosening the drain plug with a 10 mm wrench.

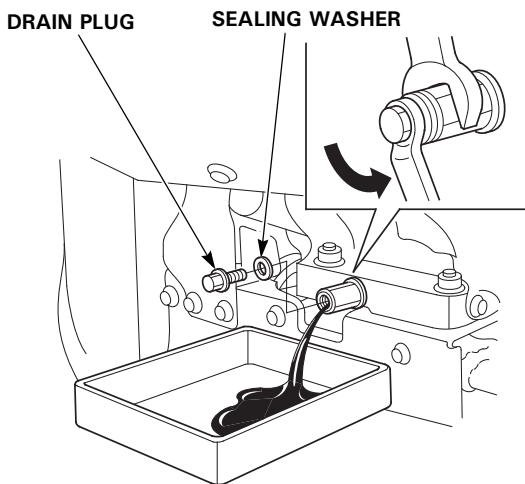

3. Allow the used oil to drain completely into an approved container.
Reinstall the drain plug with a new sealing washer, and then tighten it securely.

TORQUE: 13 ft-lb (18 N•m)

NOTICE

Improper disposal of engine oil can be harmful to the environment. If you change your own oil, please dispose of used motor oil properly. Put it in a sealed container and take it to a recycling center. Do not throw it in the trash, pour it on the ground, or pour it down a drain.

SERVICING YOUR SNOW BLOWER

4. With the engine in a level position, fill to the upper limit on the dipstick with the recommended oil (shown below). Do not thread the dipstick in when checking the oil level.

Maximum oil capacity: 1.2 US qt (37 oz, 1.1 L)

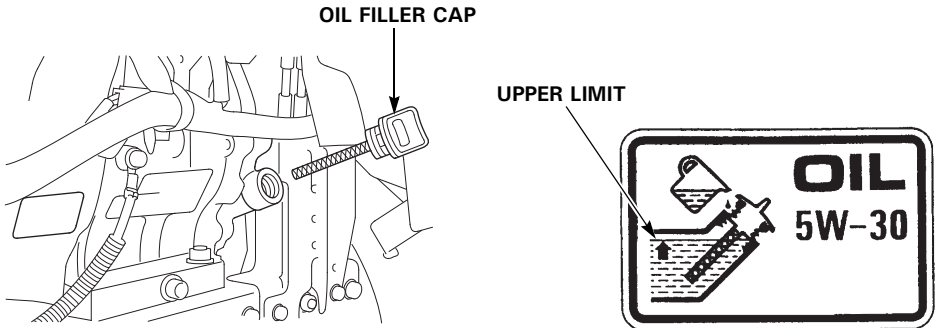

NOTICE

Running the engine with a low oil level can cause engine damage. This type of damage is not covered by the Distributor's Limited Warranty.

5. Reinstall the oil filler cap securely.

ENGINE OIL RECOMMENDATIONS

Oil is a major factor affecting performance and service life. Use a 4-stroke automotive detergent oil.

SAE 5W-30 is recommended for general use.

The SAE oil viscosity and service classification are on the API label on the oil container. Honda recommends that you use API SERVICE category SJ or later (or equivalent) oil.

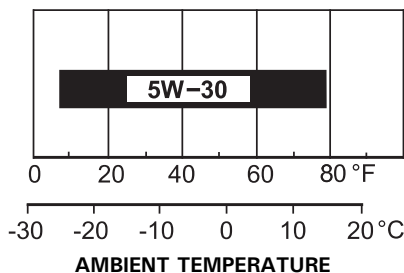

SERVICING YOUR SNOW BLOWER

SPARK PLUG SERVICE

Required spark plug: BPR5ES (NGK) or W16EPR-U (DENSO)

NOTICE

Use only the required spark plug or equivalent. Spark plugs which have an improper heat range may cause engine damage.

To ensure proper engine operation, the spark plug must be properly gapped and free of deposits. If the engine has been running, the muffler will be very hot. Be careful not to touch the muffler.

1. Remove the spark plug cap.
2. Clean any dirt from around the spark plug base.
3. Use the spark plug wrench supplied in the tool kit to remove the spark plug.
4. Inspect the spark plug. Replace it if the electrodes are worn or if the insulator is cracked, chipped, or fouled.

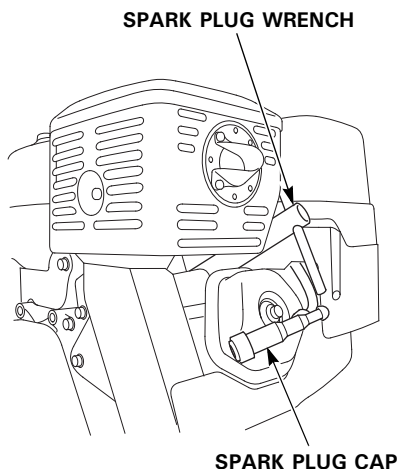

Shown without muffler protector for clarity.

SERVICING YOUR SNOW BLOWER

5. Measure the plug gap with a wire-type feeler gauge. Adjust as necessary by carefully bending the side electrode.

The gap should be:

0.028–0.031 in (0.7–0.8 mm)

6. Make sure that the spark plug sealing washer is in good condition, and thread the spark plug in by hand to prevent cross-threading.

7. After the spark plug is seated, tighten with a spark plug wrench to compress the washer.

TORQUE: 13 ft-lb (18 N•m)

If you don't have a torque wrench, install a new spark plug and tighten 1/2 turn after the spark plug seats to compress the washer. If reinstalling a used spark plug, tighten 1/8 to 1/4 turn after the spark plug seats.

NOTICE

The spark plug must be securely tightened. An improperly tightened spark plug can become very hot and may damage the engine.

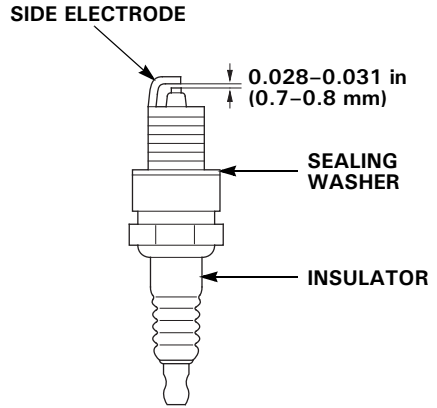

SERVICING YOUR SNOW BLOWER

TRACK ADJUSTMENT

Make sure the tracks are clean and dry before adjustment. The tracks cannot be correctly adjusted if clogged with snow or debris, or coated with ice.

With the snow blower resting on its tracks, check track deflection by pressing down midway between the wheels with a force of 11 lbf (49 N).

When correctly adjusted, track deflection should be:
7/16–5/8 in (11–16 mm)

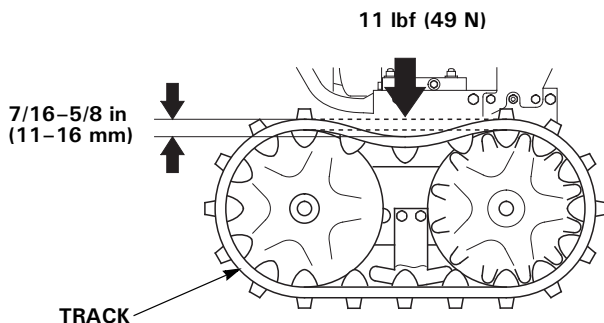

Adjusting Procedure

1. Loosen the left and right tension bolt lock nuts at the rear axle, and turn the adjusting nuts to correctly tension both tracks.
2. After adjustment, tighten the lock nuts securely.

TORQUE: 16 ft-lb (21.5 N•m)

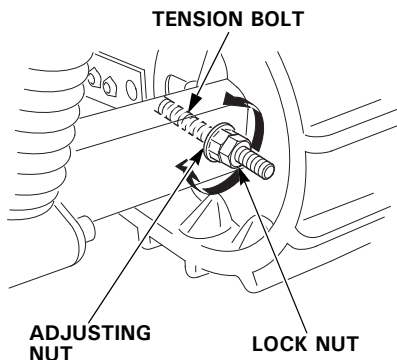

SERVICING YOUR SNOW BLOWER

TIRE INSPECTION

1. Check the side wall and tread surface of each tire for cracks, damage, or excessive wear.
2. Check the tire pressure.

Tire pressure: 20 psi (138 kPa)

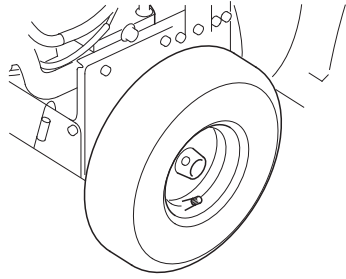

NOTICE

Excessive inflation pressure can damage the tires. Do not inflate the tires beyond 20 psi (138 kPa).

AUGER AND BLOWER INSPECTION

Check the auger, auger housing, blower, and shear bolts for signs of damage or other faults. If any of the shear bolts are broken, replace them with the ones furnished with the snow blower. Additional shear bolts and nuts are available from authorized Honda snow blower dealers.

NOTICE

Shear bolts are designed to break under force that would otherwise damage auger and blower parts. Do not replace shear bolts with ordinary hardware bolts.

SERVICING YOUR SNOW BLOWER

SHEAR BOLT REPLACEMENT

Always use correctly sized replacement shear bolts. Use of bolts other than correctly sized shear bolts can cause damage to your snow blower.

1. Place the snow blower on a firm, level surface.
2. Turn the engine switch OFF, and remove the cap from the spark plug.
3. Clean the auger and blower of snow, ice, or any other foreign particles.
4. Check the entire snow clearing mechanism.
5. Replace any broken shear bolts. Tighten securely.

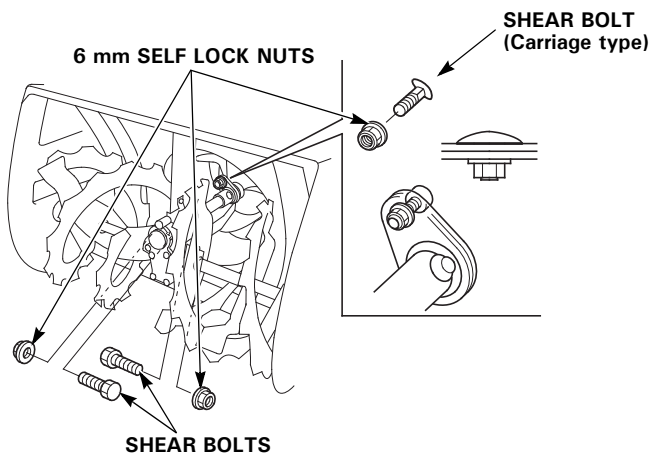

SERVICING YOUR SNOW BLOWER

SKID SHOES AND SCRAPER

To service, turn the engine switch to the OFF position and disconnect the spark plug cap so the engine cannot be accidentally started while you are near the auger.

The skids are installed on the rear of the auger housing for track models (AT, ATD) and on the side for wheel models (AW, AWD).

Wheel models (AW, AWD):

For better clearing of hard packed snow, remove the side skid shoes and install the included rear skid shoes to the auger housing.

Wear Inspection

1. Raise the auger housing off the ground.
2. Measure the thickness of the right and left skid shoes at their thinnest point.

If the thickness of the skid contacting the ground surface is 0.02 in (0.5 mm), turn the skid upside down.

Replace the skid if the thickness is less than 0.02 in (0.5 mm) after turning the skid upside down.

Adjustment

1. Place the snow blower on a level surface.
2. Track models: Depress the auger height lever, push down on the handlebars to raise the auger off the ground and then slowly lower the auger until the skid shoes contact the ground.
3. Loosen the skid shoe bolts and adjust the skid shoes to obtain the auger ground clearance for snow conditions recommended on the next page. Adjust the right and left skid shoes equally. Retighten the bolts.

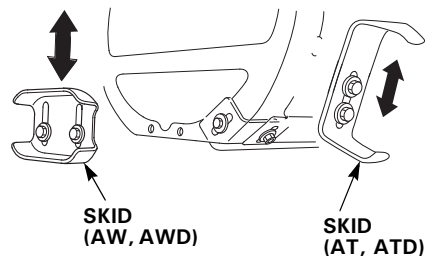

SERVICING YOUR SNOW BLOWER

4. After adjusting, raise the auger off the ground and then slowly lower and make sure both skid shoes contact the ground at the same time.

Auger clearance:

Ordinary snow conditions	5/32–5/16 in (4.0–8.0 mm)
Smooth, ice-covered surfaces	0–3/16 in (0–5.0 mm)
Rough or uneven surfaces	1–1-3/16 in (25.0–30.0 mm)

NOTICE

Operation on rough or uneven surfaces with less than the recommended auger ground clearance can damage the snow blower.

5. Check the scraper ground clearance and readjust if necessary.

Scraper Ground Clearance	3/32–5/32 in (2.0–4.0 mm)
--------------------------	---------------------------

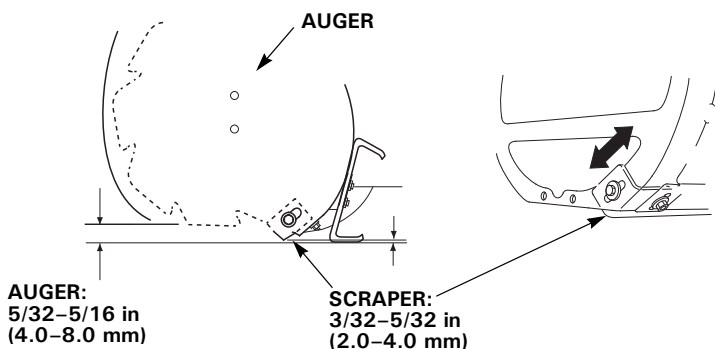

Adjust the scraper equally on both sides so it runs parallel with the ground. Be sure to tighten the scraper bar bolts and nuts after making adjustments.

TORQUE: (2) Scraper Bar Bolts 18.5 ft-lb (25.1 N•m)
(5) Nuts 19.5 ft-lb (26.5 N•m)

STORAGE

STORAGE PREPARATION

Proper storage preparation is essential for keeping your snow blower trouble-free and looking good. The following steps will help to keep rust and corrosion from impairing your snow blower's function and appearance, and will make the engine easier to start when you use the snow blower again.

Cleaning

1. Rinse the auger housing and wheels (or tracks) with a garden hose. Wipe the rest of the snow blower with a moist rag.
2. After the snow blower has dried, touch up any damaged paint.
3. Lubricate the areas shown in the graphic before storage.

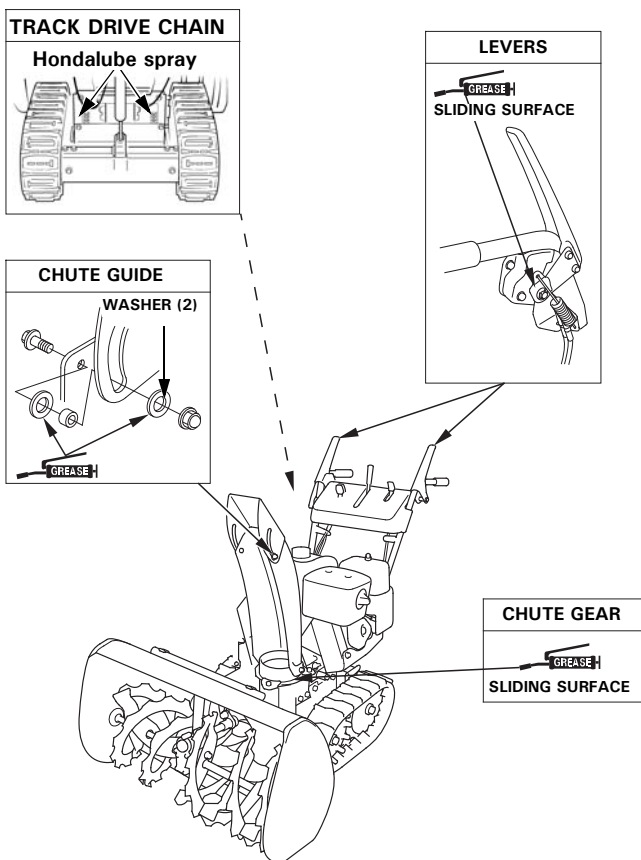

Fuel

NOTICE

Depending on the region where you operate your equipment, fuel formulations may deteriorate and oxidize rapidly. Fuel deterioration and oxidation can occur in as little as 30 days and may cause damage to the carburetor and/or fuel system. Please check with your servicing dealer for local storage recommendations.

Gasoline will oxidize and deteriorate in storage. Old gasoline will cause hard starting, and it leaves gum deposits that clog the fuel system. If the gasoline in your snow blower deteriorates during storage, you may need to have the carburetor and other fuel system components serviced or replaced.

The length of time that gasoline can be left in your fuel tank and carburetor without causing functional problems will vary with such factors as gasoline blend, your storage temperatures, and whether the fuel tank is partially or completely filled. The air in a partially filled fuel tank promotes fuel deterioration. Very warm storage/temperatures accelerate fuel deterioration. Fuel deterioration problems may occur within a few months, or even less if the gasoline was not fresh when you filled the fuel tank.

The *Distributor's Limited Warranty* does not cover fuel system damage or engine performance problems resulting from neglected storage preparation.

You can extend fuel storage life by adding a fuel stabilizer that is formulated for that purpose, or you can avoid fuel deterioration problems by draining the fuel tank and carburetor.

STORAGE

Adding a Fuel Stabilizer to Extend Fuel Storage Life

When adding a fuel stabilizer, fill the fuel tank with fresh gasoline. If only partially filled, air in the tank will promote fuel deterioration during storage. If you keep a container of gasoline for refueling, be sure that it contains only fresh gasoline.

Add fuel stabilizer following the manufacturer's instructions.

After adding a fuel stabilizer, run the engine outdoors for 10 minutes to be sure that treated gasoline has replaced the untreated gasoline in the carburetor.

Service according to the table below:

STORAGE TIME	RECOMMENDED SERVICE PROCEDURE TO PREVENT HARD STARTING
Less than 1 month	Fill with fresh gasoline to prevent moisture buildup.
1 to 3 months	Fill with fresh gasoline and add gasoline stabilizer according to the manufacturer's instructions. With the fuel valve in the OFF position, start the engine and let run until the engine stops.
More than 3 months	Drain the fuel tank and carburetor (see page 59).

Draining the Fuel Tank and Carburetor

1. Place an approved gasoline container below the carburetor, and use a funnel to avoid spilling fuel.
2. Loosen the carburetor drain knob, then move the fuel valve lever to the ON position. Drain the carburetor until the fuel tank is empty.

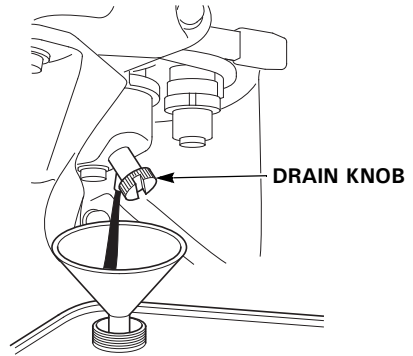

⚠ WARNING

Gasoline is highly flammable and explosive. You can be burned or seriously injured when handling fuel.

- Keep heat, sparks, and flames away.
- Handle fuel only outdoors.
- Wipe up spills immediately.

3. After draining, tighten the drain knob and turn the fuel valve OFF.
4. Remove the fuel sediment cup. **Do not remove the O-ring.** Confirm the O-ring is properly positioned and in good condition. Contact your authorized Honda dealer if the O-ring needs to be replaced.

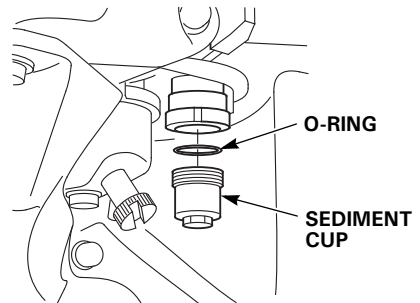

5. Empty the contents of the sediment cup into a suitable container. Clean the fuel sediment cup.
6. Reinstall the sediment cup and tighten securely.

STORAGE

Engine Oil

1. Change the engine oil (see page [47](#)).
2. Remove the spark plug (see page [49](#)).
3. Pour a teaspoon (5 cc) of clean engine oil into the cylinder.
4. Pull the starter rope slowly several times to distribute the oil.
5. Reinstall the spark plug.
6. Pull the starter grip slowly until you feel resistance, then return the starter grip gently. This will close the valves so moisture cannot enter the engine cylinder.

Tires

Check the air pressure (see page [52](#)).

Battery Service (electric start models)

If the snow blower will be stored for an extended period, remove the battery and store in a cool, dry place.

Recharge the battery every 6 months or if the voltage is less than 12.9 V. Recharge every year before operation and before storage (see page [61](#)).

Battery Removal/Charging/Installation

A commercially available 12 V battery charger should be used that can be adjusted to deliver 2 amps or less. An automatic battery charger is recommended (see page 73).

1. Remove the battery cover by first pulling the battery strap from the bottom hook. Pull the cover upward to unsnap the two cover pins.

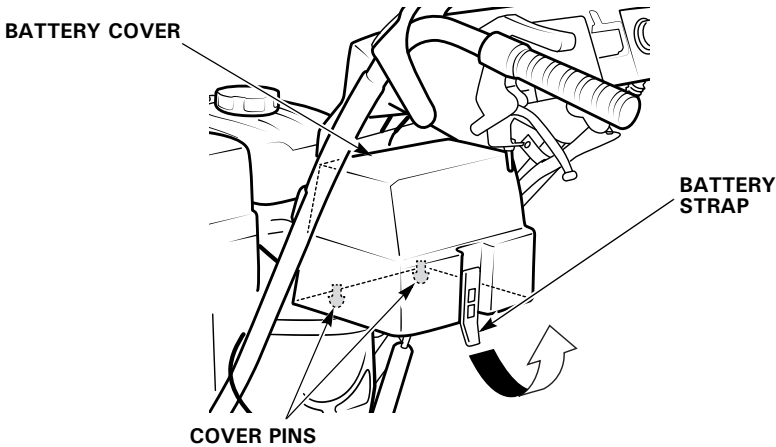

2. Remove the negative (-) cable from the battery negative (-) terminal and then remove the positive (+) cable from the battery positive (+) terminal.

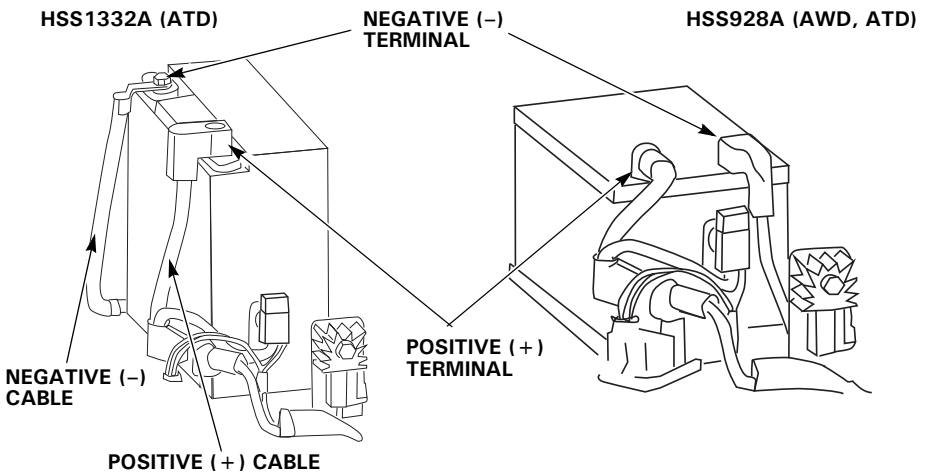

STORAGE

3. To remove the battery, remove the battery strap from the bottom hook.
4. Connect the battery charger positive (+) cable to the battery positive (+) terminal and then connect the battery charger negative (-) cable to the battery negative (-) terminal.
5. Charge the battery: 5–10 hours at 1.2 A (HSS928A)
5–10 hours at 1.8 A (HSS1332A)
6. Install the battery in the reverse order of removal.
7. Install the battery cover by aligning the cover pins with the grommets and firmly pushing down on the front side of the cover to engage the cover pins into the grommets.



This symbol on the battery means that this product must not be treated as household waste.

NOTICE

An improperly disposed of battery can be harmful to the environment and human health. Always confirm local regulations for battery disposal.

Fuse Replacement

Rotate the fuse holder cover and pull the fuse out. If blown, replace with a fuse of the same type and rating.

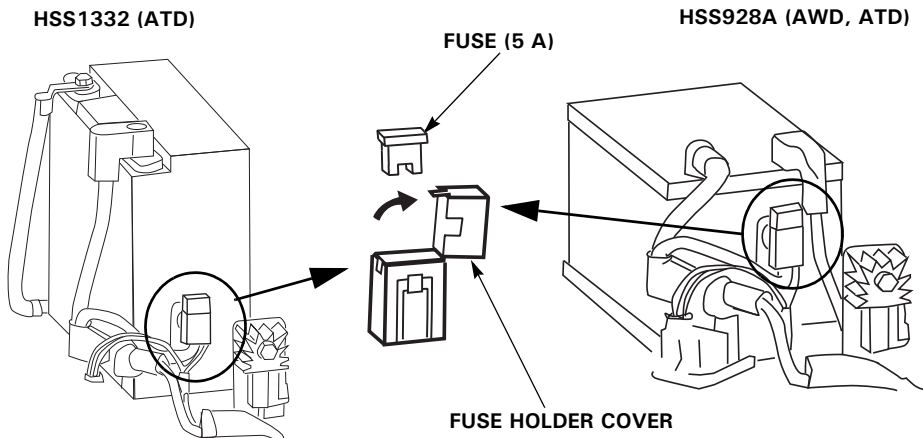

STORAGE PRECAUTIONS

If your snow blower will be stored with gasoline in the fuel tank and carburetor, it is important to reduce the hazard of gasoline vapor ignition. Select a well-ventilated storage area away from any appliance that operates with a flame, such as a furnace, water heater, or clothes dryer. Also avoid any area with a spark-producing electric motor, or where power tools are operated.

If possible, avoid storage areas with high humidity, which promote rust and corrosion.

Unless all fuel has been drained from the fuel tank, leave the fuel valve in the OFF position to reduce the possibility of fuel leakage.

Place the snow blower on a level surface. Tilting can cause fuel or oil leakage.

With the engine and exhaust system completely cooled, cover the snow blower to keep out dust. A hot engine and exhaust system can ignite or melt some materials. Do not use sheet plastic as a dust cover. A nonporous cover will trap moisture around the engine, promoting rust and corrosion.

REMOVAL FROM STORAGE

Check your snow blower as described in the *BEFORE OPERATION* chapter (see page [25](#)) of this manual.

If the fuel was drained during storage preparation, fill the tank with fresh gasoline. If you keep a container of gasoline for refueling, be sure that it contains only fresh gasoline. Gasoline oxidizes and deteriorates over time, causing hard starting.

If the cylinder was coated with oil during storage preparation, the engine may smoke briefly at startup. This is normal.

TRANSPORTING

BEFORE LOADING

1. Loading the snow blower on a trailer should be performed on a firm, level surface.
2. Use a loading ramp that is strong enough to support the combined weight of the snow blower and the operator.

Weight of snow blower (operating weight):

Types \ Models	HSS928A	HSS1332A
AT	276 lbs (125 kg)	298 lbs (135 kg)
ATD	287 lbs (130 kg)	320 lbs (145 kg)
AW	243 lbs (110 kg)	—
AWD	254 lbs (115 kg)	—

3. The loading ramp must be long enough so that its slope is 15° (26%) or less.

Length of Ramp (L)	8.2 ft (2.5 m)	9.8 ft (3.0 m)	11.5 ft (3.5 m)
Height (H)	2.1 ft (65 cm)	2.5 ft (75 cm)	3.0 ft (90 cm)

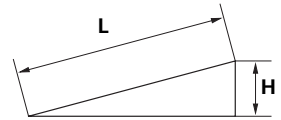

4. If the truck bed has a low roof or cover with less than 5 ft (1.5 m) of headroom, lower the discharge deflector for better clearance or remove the chute assembly.
5. Ensure there is sufficient fuel in the tank. The engine may stall on the ramp if there is not enough fuel in the tank.

LOADING

1. Track type: Raise the auger to the HIGH position (see page 21).
2. Start the engine and maneuver the snow blower backward in line with the loading ramp.
3. Track type: Run the snow blower backward slowly up the loading ramp.

Wheel type: Push down the handles to raise the auger and run the snow blower up the loading ramp.

Be careful to avoid striking the chute or other parts of the machine.

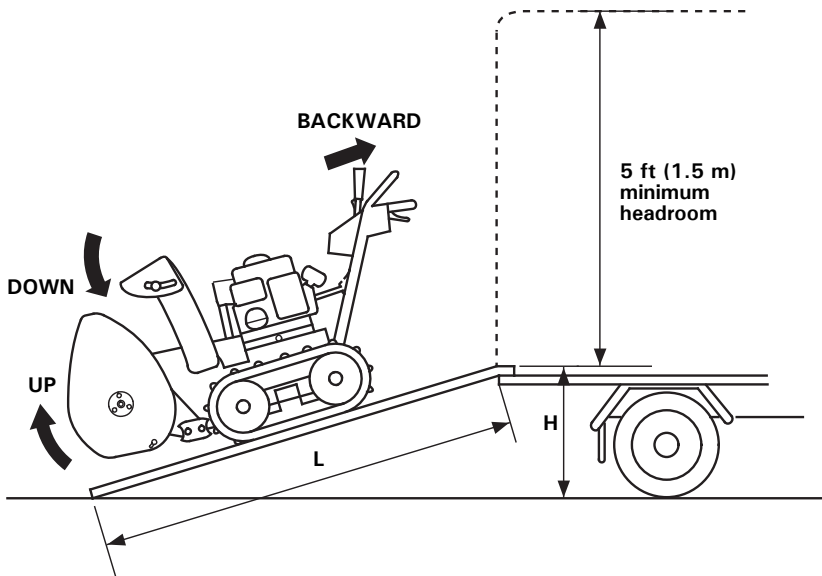

4. After the snow blower is in the truck, stop the engine, and turn the fuel valve to the OFF position. This will prevent the possibility of carburetor flooding and will reduce the possibility of fuel leakage.
5. Tie the snow blower down with rope or straps, and block the treads. Keep the tie-down rope or straps away from controls and cables.

TRANSPORTING

Track models: Lower the auger housing so the skids rest on the vehicle floor.

Do not tie with rope or straps stronger than necessary to prevent damage to the snow blower.

Tie-down Points

Front

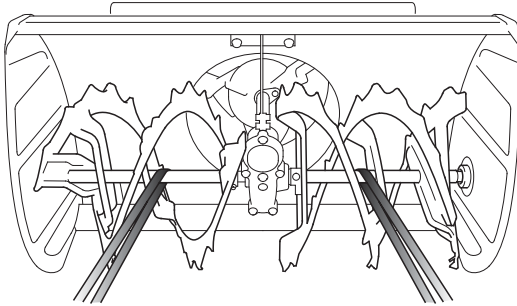

Rear

Track type:

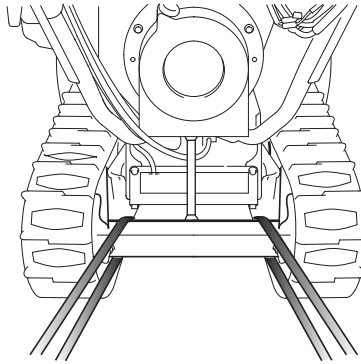

Wheel type:

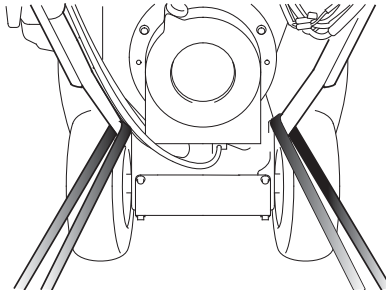

TAKING CARE OF UNEXPECTED PROBLEMS

ENGINE PROBLEMS

Starter operates, but engine will not start

Possible cause	Correction
Throttle not in proper position.	Throttle must be in FAST position, choke OFF for a hot start, choke ON for a cold start.
Fuel valve is OFF. Sediment cup obstructed.	Turn fuel valve lever to ON (see page 15). Check for contaminants in sediment cup (see page 59).
Stale or old fuel.	Be sure tank has fresh fuel. Drain carburetor and sediment cup (see page 59).
Spark plug cap off. Improper electrode gap or deposits in the spark plug gap.	Make sure cap is connected. Verify that spark plug is free of deposits, and has proper gap (see page 49).

Engine has low power

Possible cause	Correction
Throttle lever not in the FAST position.	Always move the throttle lever to FAST when blowing snow.
Too fast ground speed when blowing wet, deep snow puts excessive load on engine.	Blow snow at slower ground speed.
Wet, deep cuts place excessive load on engine.	Reduce snow blowing swath.
Discharge chute restricted.	Clear discharge chute obstructions (see page 22).

TAKING CARE OF UNEXPECTED PROBLEMS

Engine has low power (continued)

Possible cause	Correction
Spark plug cap not secure. Improper electrode gap or deposits on the electrodes.	Make sure spark plug cap is securely connected. Verify the spark plug is free of deposits and has the proper gap.
Choke in wrong position or choke plate sticking.	Check choke plate movement.
Stale or old fuel.	Add fresh fuel. Drain carburetor and sediment cup (see page 59).

DRIVE PROBLEMS

Engine runs, but snow blower doesn't move

Possible cause	Correction
Drive clutch lever is in the DISENGAGED position.	Move lever to the ENGAGED position (see page 18).
Shift lever is in "N" (Neutral).	Move shift lever to "F" or "R" (see page 17).
Drive clutch lever mechanism or cable not functioning properly.	See servicing Honda snow blower dealer.
Drive belt worn, broken or not on pulleys.	See servicing Honda snow blower dealer.

SNOW BLOWER PROBLEMS

Won't blow snow

Possible cause	Correction
Auger clutch lever is in the DISENGAGED position.	Move lever to the ENGAGED position (see page 18).
Shear bolt(s) broken.	Replace broken shear bolt(s).
Discharge chute restricted. Foreign object stopping auger from rotating.	Clear discharge chute of obstructions (see page 22). Remove foreign object.
Belt worn, not on pulleys or not properly installed.	See servicing Honda snow blower dealer.

TAKING CARE OF UNEXPECTED PROBLEMS

Snow not discharging properly

Possible cause	Correction
Auger spinning too slowly.	Keep throttle in FAST position (see page 16).
Wet, deep snow is difficult to blow.	Reduce snow blowing swath or speed.
Belt worn, not on pulleys or not properly installed.	See servicing Honda snow blower dealer.
Snow blower moving too fast for snow conditions.	Use shift lever to reduce ground speed (see page 17).

Engine stalls when auger clutch lever is depressed

Possible cause	Correction
Engine running too slow.	Keep throttle in FAST position when engaging auger clutch (see page 16).
Discharge chute restricted. Foreign object stopping auger from rotating. Auger frozen by ice.	Clear discharge chute or auger housing of obstruction.

TECHNICAL INFORMATION

Serial Number Locations

Record the engine and frame serial numbers in the spaces below. You will need these serial numbers when ordering parts, and when making technical or warranty inquiries (see page 78).

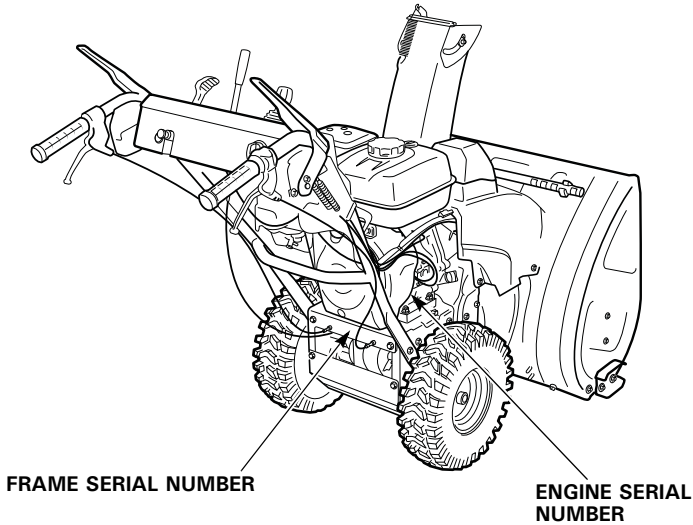

Engine serial number: _____

Frame serial number: _____

Date of purchase: _____

Carburetor Modification for High Altitude Operation

At high altitude, the standard carburetor air-fuel mixture will be too rich. Performance will decrease, and fuel consumption will increase. A very rich mixture will also foul the spark plug and cause hard starting. Operation at an altitude that differs from that at which this engine was certified, for extended periods of time, may increase emissions.

High altitude performance can be improved by specific modifications to the carburetor. If you always operate your snow blower at altitudes above 5,000 feet (1,500 meters) have your servicing dealer perform this carburetor modification. This engine, when operated at high altitude with the carburetor modifications for high altitude use, will meet each emission standard throughout its useful life.

Even with carburetor modification, engine horsepower will decrease about 3.5% for each 1,000-foot (300-meter) increase in altitude. The effect of altitude on horsepower will be greater than this if no carburetor modification is made.

NOTICE

When the carburetor has been modified for high altitude operation, the air-fuel mixture will be too lean for low altitude use. Operation at altitudes below 5,000 feet (1,500 meters) with a modified carburetor may cause the engine to overheat and result in serious engine damage. For use at low altitudes, have your servicing dealer return the carburetor to original factory specifications.

TECHNICAL INFORMATION

Emission Control System Information

Source of Emissions

The combustion process produces carbon monoxide, oxides of nitrogen, and hydrocarbons. Control of hydrocarbons and oxides of nitrogen is very important because, under certain conditions, they react to form photochemical smog when subjected to sunlight. Carbon monoxide does not react in the same way, but it is toxic.

Honda utilizes appropriate air/fuel ratios and other emissions control systems to reduce the emissions of carbon monoxide, oxides of nitrogen and hydrocarbons.

The U.S. and California Clean Air Acts

EPA and California regulations require all manufacturers to furnish written instructions describing the operation and maintenance of emission control systems.

The following instructions and procedures must be followed in order to keep the Honda engine emissions within the emission standards.

Tampering and Altering

NOTICE

Tampering is a violation of federal and California law.

Tampering with or altering the emission control system may increase emissions beyond the legal limit. Among those acts that constitute tampering are:

- Removal or alteration of any part of intake, fuel or exhaust system
- Altering or defeating the governor linkage or speed-adjusting mechanism to cause the engine to operate outside its design parameters

Problems That May Affect Emissions

If you are aware of any of the following symptoms, have your engine inspected and repaired by your authorized Honda servicing dealer.

- Hard starting or stalling after starting
- Rough idle
- Misfiring or backfiring under load
- Afterburning (backfiring)
- Black exhaust smoke or high fuel consumption

Replacement Parts

The emission control systems on your new Honda engine were designed, built, and certified to conform with EPA and California emission regulations. We recommend the use of Honda Genuine parts whenever you have maintenance done. These original design replacement parts are manufactured to the same standards as the original parts, so you can be confident of their performance. The use of replacement parts that are not of the original design and quality may impair the effectiveness of your emission control system.

A manufacturer of an aftermarket part assumes the responsibility that the part will not adversely affect emission performance. The manufacturer or rebuilder of the part must certify that use of the part will not result in a failure of the engine to comply with emission regulations.

Maintenance

Follow the *Maintenance Schedule* on pages [42](#) and [43](#). Remember this schedule is based on the assumption that your machine will be used for its designed purpose. Sustained high load operation will require more frequent service.

TECHNICAL INFORMATION

Air Index

An Air Index Information hang tag/label is applied to engines certified to an emission durability time period in accordance with the requirements of the California Air Resources Board.

The bar graph is intended to provide you, our customer, the ability to compare the emissions performance of available engines. The lower the Air Index, the less pollution.

The durability description is intended to provide you with information relating to the engine's emission durability period. The descriptive term indicates the useful-life period for the engine's emission control system. See your *Emission Control Warranty* for additional information.

Descriptive Term	Applicable to Emission Durability Period
Moderate	50 hours (0 – 80 cc, inclusive) 125 hours (greater than 80 cc)
Intermediate	125 hours (0 – 80 cc, inclusive) 250 hours (greater than 80 cc)
Extended	300 hours (0 – 80 cc, inclusive) 500 hours (greater than 80 cc) 1,000 hours (225 cc and greater)

TECHNICAL INFORMATION

Specifications

Frame

Model	HSS928A				
Items	Type	AT	ATD	AW	AWD
Description code	SADA				
Overall length	58.5 in (1,485 mm)				
Overall width	28.9 in (735 mm)		30.5 in (775 mm)		
Overall height	43.5 in (1,105 mm)				
Handlebar height	37.0 in (940 mm)		36.6 in (930 mm)		
Dry mass [weight]	265 lbs (120 kg)	276 lbs (125 kg)	231 lbs (105 kg)	243 lbs (110 kg)	
Width of snow clearance	28.0 in (710 mm)				
Height of snow clearance	21.7 in (550 mm)				
Snow throwing distance (varies with snow conditions)	Max. 52 ft (16 m)				
Clearing capacity	52 [metric] (57 [short]) Ton/hour				

Engine

Model	Honda GX270			
Displacement	16.5 cu-in (270 cm ³)			
Bore × stroke	3.03 × 2.28 in (77.0 × 58.0 mm)			
Starting method	Recoil starter	Recoil starter or DC electric starter	Recoil starter	Recoil starter or DC electric starter
Ignition system	CDI magneto			
Oil capacity	1.2 US qt (37 oz, 1.1 L)			
Fuel tank capacity	1.3 US gal (5.0 L)			
Spark plug	BPR5ES (NGK) W16EPR-U (DENSO)			

Tuneup

ITEM	SPECIFICATION	MAINTENANCE
Spark plug gap	0.028–0.031 in (0.7–0.8 mm)	Refer to page 49.
Valve clearance	IN: 0.15 ± 0.02 mm EX: 0.20 ± 0.02 mm	See your authorized Honda dealer
Other specifications	No other adjustments needed.	

Specifications are subject to change without notice.

TECHNICAL INFORMATION

Frame

Model	HSS1332A	
Items	Type	
	AT	ATD
Description code	SAFA	
Overall length	58.5 in (1,485 mm)	
Overall width	32.9 in (835 mm)	
Overall height	43.5 in (1,105 mm)	48.4 in (1,230 mm)
Handlebar height	37.0 in (940 mm)	
Dry mass [weight]	276 lbs (125 kg)	298 lbs (135 kg)
Width of snow clearance	31.9 in (810 mm)	
Height of snow clearance	21.7 in (550 mm)	
Snow throwing distance (varies with snow conditions)	Max. 56 ft (17 m)	
Clearing capacity	75 [metric] (83 [short]) Ton/hour	

Engine

Model	Honda GX390	
Displacement	23.7 cu-in (389 cm ³)	
Bore × stroke	3.46 × 2.52 in (88.0 × 64.0 mm)	
Starting method	Recoil starter	Recoil starter or DC electric starter
Ignition system	CDI magneto	
Oil capacity	1.2 US qt (37 oz, 1.1 L)	
Fuel tank capacity	1.5 US gal (5.7 L)	
Spark plug	BPR5ES (NGK) W16EPR-U (DENSO)	

Tuneup

ITEM	SPECIFICATION	MAINTENANCE
Spark plug gap	0.028–0.031 in (0.7–0.8 mm)	Refer to page 49 .
Valve clearance	IN: 0.15 ± 0.02 mm EX: 0.20 ± 0.02 mm	See your authorized Honda dealer
Other specifications	No other adjustments needed.	

Specifications are subject to change without notice.

CONSUMER INFORMATION

Dealer Locator Information

To find an authorized Honda Servicing Dealer anywhere in the United States, visit our website at powerequipment.honda.com and click on Dealer Locator.

Honda Publications

Shop Manual

This manual covers complete maintenance and overhaul procedures. It is intended to be used by a skilled technician. Visit our website at powerequipment.honda.com and click on Product Support.

Parts Catalog

This manual provides complete, illustrated parts lists and is available through your Honda dealer.

Accessories Catalog

Your authorized Honda Power Equipment dealer offers a selection of accessories (optional equipment) to make your snow blower even more useful. Visit our website at powerequipment.honda.com and click on Snow Blowers to see the entire catalog of accessories.

CONSUMER INFORMATION

Customer Service Information

Honda Power Equipment dealership personnel are highly trained professionals. They should be able to answer any question you may have. If you encounter a problem that your dealer does not solve to your satisfaction, please discuss it with the dealership's management. The Service Manager or General Manager can help. Almost all problems are solved in this way.

If you are dissatisfied with the decision made by the dealership's management, contact the Honda Power Equipment Customer Relations Office. You can write:

American Honda Motor Co., Inc.
Power Equipment Division
Customer Relations Office
4900 Marconi Drive
Alpharetta, Georgia 30005-8847

Or telephone: (770) 497-6400 M-F, 8:30 am to 7:00 pm ET

When you write or call, please provide this information:

- Model and serial number (see page [70](#))
- Name of the dealer who sold the snow blower to you
- Name and address of the dealer who services your snow blower
- Date of purchase
- Your name, address, and telephone number
- A detailed description of the problem

CONSUMER INFORMATION

REPLACEMENT PARTS, OPTIONAL EQUIPMENT, AND SERVICE ITEMS

Contact an authorized Honda servicing dealer to purchase any of these (or other) Honda Genuine items for your snow blower.

Replacement Parts

Item	Part Number	Notes
Spark plug	98079-55846	NGK - BPR5ES
Shear bolt	90121-V45-A00 90119-V45-A00	Blower 6 x 18 (carriage type) Auger 6 x 18
Fuse	98200-40500	5 Amp

Optional Equipment

Item	Part Number	Notes
Cover	See your local dealer.	Custom fitted, waterproof, and breathable
NO-SPILL [®] gas can	See your local dealer.	1-1/4 gallon or 2-1/2 gallon
Cold weather cab	04700-V45-000AH	
Drift breaker	06760-768-000AH	
Commercial grade side mount skid shoes	04700-768-E110	Heavy duty, 1/2 inch thick steel
Float charger	See your local dealer.	Battery charging

No-Spill[®] is a registered trademark of NoSpill LLC.

Service Items

Item	Part Number	Notes
SAE 5W-30 engine oil (1 qt)	08207-5W30	Honda Genuine recommended oil
Fuel stabilizer (500 ml)	08732-0800	For long term storage
Hondalube	08732-RP001	Track drive model chain lube
Touch-up paint	08707-R280	Honda Red (aerosol)

DISTRIBUTOR'S LIMITED WARRANTY

Honda Power Equipment

This warranty is limited to the following Honda Power Equipment products when distributed by American Honda Motor Co., Inc., Power Equipment Division, 4900 Marconi Drive, Alpharetta, Georgia 30005. The following warranty applies to products purchased at retail or placed in rental service on or after January 1, 2010.

Product Covered by this Warranty	Length of Warranty (1) (from date of original retail purchase)	
	Private Residential	Commercial/Rental/ Institutional
HSS928A/HSS1332A Snow Blowers	36 months	36 months

(1) Length of warranty: The battery supplied with the applicable products as standard, original equipment is covered by this warranty for a period of 12 months (private residential) or 3 months (commercial/rental/institutional use) from the date of original retail product purchase.

To Qualify for This Warranty:

The product must be purchased in the United States, Puerto Rico, or the U.S. Virgin Islands from American Honda or a dealer authorized by American Honda to sell those products. This warranty applies to first retail purchaser and each subsequent owner during the applicable warranty time period, unless noted otherwise.

What American Honda Will Repair or Replace Under Warranty:

American Honda will repair or replace, at its option, any part that is proven to be defective in material or workmanship under normal use during the applicable warranty time period. Warranty repairs and replacements will be made without charge for parts or labor. Anything replaced under warranty becomes the property of American Honda Motor Co., Inc. All parts replaced under warranty will be considered as part of the original product, and any warranty on those parts will expire coincident with the original product warranty.

To Obtain Warranty Service:

You must, at your expense, take the Honda Power Equipment product, accessory, replacement part, apparel, or the power equipment on which the accessory or replacement part is installed, and proof of purchase to any Honda Power Equipment dealer in the United States, Puerto Rico, or the U.S. Virgin Islands who is authorized to sell and/or service that product, during the dealer's normal business hours. To locate a dealer near you, visit our web site at <http://PowerEquipment.Honda.com> and click on Find a Dealer.

If you are unable to obtain warranty service or are dissatisfied with the warranty service you receive, contact the owner of the dealership involved; normally this will resolve the problem. However, if you should require further assistance, write or call the Power Equipment Customer Relations Department of American Honda Motor Co., Inc. at the address on page 78.

DISTRIBUTOR'S LIMITED WARRANTY

Exclusions:

1. Any damage or deterioration resulting from the following:
 - Neglect of the periodic maintenance as specified in the product owner's manual
 - Improper repair or maintenance
 - Operating methods other than those indicated in the product owner's manual
 - The use of non-genuine Honda parts, accessories, lubricants, and fluids other than those approved by Honda
 - Exposure of the product to soot and smoke, chemical agents, bird droppings, sea water, salt, or other corrosive environments
 - Collision, fuel contamination or deterioration, neglect, unauthorized alteration, misuse, incorporation or use of unsuitable attachments or parts
 - Normal wear and tear (including, but not limited to, normal fading of painted or plated surfaces, sheet peeling, and other natural deterioration)
2. Consumable parts: Honda does not warrant parts deterioration due to normal wear and tear. The following parts are not covered by this warranty unless they are needed during another repair covered under this warranty: spark plug, fuel filter, air cleaner element, clutch disc, tire, wheel bearing, recoil starter rope, cable, belt, cutter blade, oil, and grease.
3. Cleaning, adjustment, and normal periodic maintenance work (carburetor cleaning, engine oil draining, blade sharpening, belt and cable adjustments).
4. Any product that has ever been declared a total loss or sold for salvage by a financial institution or insurer.
5. Auger and paddle assemblies, skid shoes, and scraper bars of snow throwers, tiller tines of roto-tillers, and mower blades and mower deck housings are specifically not warranted against impact damage including, but not limited to, abrasive damage.

Disclaimer of Consequential Damage and Limitation of Implied Warranties:

American Honda disclaims any responsibility for loss of time or use of the product, transportation, commercial loss, or any other incidental or consequential damage. Any implied warranties are limited to the duration of this written limited warranty. Some states do not allow limitations on how long an implied warranty lasts and/or do not allow the exclusion or limitation of incidental or consequential damages, therefore the above exclusions and limitations may not apply to you. This warranty gives you specific legal rights, and you may also have other rights, which vary from state to state.

EMISSION CONTROL SYSTEM WARRANTY

Your new Honda Power Equipment engine complies with the U.S. EPA, Environment Canada, and State of California (models certified for sale in California only) emission regulations. American Honda Motor Co., Inc. provides the emission warranty coverage for engines in the United States and its territories. Honda Canada Inc. provides the emission warranty for engines in the 13 provinces and territories of Canada. In the remainder of this Emission Control System Warranty, American Honda Motor Co., Inc. and Honda Canada Inc. will be referred to as Honda.

YOUR WARRANTY RIGHTS AND OBLIGATIONS:

CALIFORNIA

The California Air Resources Board and Honda are pleased to explain the emission control system warranty on your 2016 and later Honda Power Equipment engine. In California, new spark-ignited small off-road equipment engines must be designed, built, and equipped to meet the state's stringent anti-smog standards. Specific Honda products that do not meet the California emissions regulations can be identified by a "Not for sale in California" decal.

OTHER STATES, U.S. TERRITORIES, AND CANADA

In other areas of the United States and in Canada, your engine must be designed, built, and equipped to meet the U.S. EPA and Environment Canada emission standards for spark-ignited engines at or below 19 kilowatts.

ALL OF THE UNITED STATES AND CANADA

Honda must warrant the emission control system on your power equipment engine for the period of time listed below, provided there has been no abuse, neglect, or improper maintenance of your power equipment engine. Where a warrantable condition exists, Honda will repair your power equipment engine at no cost to you including diagnosis, parts, and labor.

Your emission control system may include such parts as the carburetor or fuel injection system, the ignition system, and catalytic converter. Also included may be hoses, connectors, and other emission-related assemblies (see page 79 for additional covered parts).

OWNER'S WARRANTY RESPONSIBILITY:

As the power equipment engine owner, you are responsible for completing all required maintenance listed in your owner's manual. Honda recommends that you retain all receipts covering maintenance on your power equipment engine, but Honda cannot deny warranty coverage solely for the lack of receipts or for your failure to ensure that all scheduled maintenance has been completed.

As the power equipment engine owner, you should however be aware Honda may deny you warranty coverage if your power equipment engine or a part has failed due to abuse, neglect, improper maintenance, or unapproved modifications.

EMISSION CONTROL SYSTEM WARRANTY

You are responsible for presenting your power equipment engine to a Honda Power Equipment dealer as soon as a problem exists. The emission related warranty repairs should be completed in a reasonable amount of time, not to exceed 30 days.

If you have any questions regarding your emission warranty rights and responsibilities, you should contact the Honda office in your region:

American Honda Motor Co., Inc.
Power Equipment Customer Relations
4900 Marconi Drive
Alpharetta, Georgia 30005-8847
Telephone: (888) 888-3139

or

Honda Canada Inc.
Power Equipment Customer
Relations
180 Honda Blvd.
Markham, ON, L6C 0H9
Telephone: (888) 946-6329

Email:

powerequipmentemissions@ahm.honda.com

WARRANTY COVERAGE:

Honda power equipment engines sold in the United States and Canada are covered by this warranty for a period of two years from the date of delivery to the original retail purchaser or the length of the Honda Distributor's Limited Warranty, whichever is longer. This warranty is transferable to each subsequent purchaser for the duration of the warranty period.

If any emission-related part on your engine is defective, the part will be repaired or replaced by Honda without charge for diagnosis, parts, or labor. All defective parts replaced under this warranty become the property of Honda. Only Honda approved replacement parts may be used in the performance of any warranty repairs and must be provided without charge to the owner. A list of warranted parts is on the reverse side of this warranty statement. Normal maintenance items, such as spark plugs and filters, that are on the warranted parts list are warranted up to their required replacement interval only.

Honda will also replace other engine components damaged by a failure of any warranted part during the warranty period.

The use of replacement parts not equivalent to the original parts may impair the effectiveness of your engine emission control system. If such a replacement part is used in the repair or maintenance of your engine, and an authorized Honda dealer determines it is defective or causes a failure of a warranted part, your claim for repair of your engine may be denied. If the part in question is not related to the reason your engine requires repair, your claim will not be denied.

EMISSION CONTROL SYSTEM WARRANTY

TO OBTAIN WARRANTY SERVICE:

You must, at your own expense, take your Honda Power Equipment engine or the product on which it is installed, along with your sales registration card or other proof of original purchase date, to any Honda Power Equipment dealer who is authorized by Honda to sell and service that Honda product during their normal business hours. Claims for repair or adjustment found to be caused solely by defects in material or workmanship will not be denied because the engine was not properly maintained and used.

If you are unable to obtain emission warranty service or are dissatisfied with the warranty service you received, contact the owner of the dealership involved. Normally this should resolve your problem. However, if you require further assistance, contact the Honda office in your region:

American Honda Motor Co., Inc.
Power Equipment Customer Relations
4900 Marconi Drive
Alpharetta, Georgia 30005-8847
Telephone: (888) 888-3139

Honda Canada Inc.
Power Equipment Customer
Relations
180 Honda Blvd.
Markham, ON, L6C 0H9
Telephone: (888) 946-6329

Email: powerequipmentemissions@ahm.honda.com

EXCLUSIONS:

Failures other than those resulting from defects in material or workmanship are not covered by this warranty. This warranty does not extend to emission control systems or parts that are affected or damaged by owner abuse, neglect, improper maintenance, misuse, misfueling, improper storage, collision, the incorporation of, or use of, unsuitable attachments, or the unauthorized alteration of any part.

This warranty does not cover replacement of expendable maintenance items made in connection with required maintenance service after the item's first scheduled replacement as listed in the maintenance section of the product owner's manual, such as: spark plugs and filters.

DISCLAIMER OF CONSEQUENTIAL DAMAGE AND LIMITATION OF IMPLIED WARRANTIES:

American Honda Motor Co., Inc. and Honda Canada Inc. disclaim any responsibility for incidental or consequential damages such as loss of time or the use of the power equipment, or any commercial loss due to the failure of the equipment; and any implied warranties are limited to the duration of this written warranty. This warranty is applicable only where the California, U.S. EPA, or Environment Canada emission control system warranty regulation is in effect.

EMISSION CONTROL SYSTEM WARRANTY

EMISSION CONTROL SYSTEM WARRANTY PARTS:

SYSTEMS COVERED BY THIS WARRANTY:	PARTS DESCRIPTION:
Fuel Metering	Carburetor assembly (includes starting enrichment system), Oxygen sensor, Throttle body, Engine temperature sensor, Engine control module, Fuel injector, Fuel regulator, Intake manifold
Evaporative	Fuel tank, Fuel cap, Fuel hoses, Vapor hoses, Carbon canister, Canister mounting brackets, Fuel strainer, Fuel valve, Fuel pump, Fuel hose joint, Canister purge hose joint
Exhaust	Catalyst, Exhaust pipe, Muffler (with catalyst)
Air Induction	Air cleaner case, Air cleaner element*
Ignition	Flywheel comp., Flywheel magneto, Ignition pulse generator, Crankshaft position sensor, Power coil, Ignition coil assembly, Ignition control module, Spark plug cap, Spark plug*
Crankcase Emission Control	Crankcase breather tube, Breather valve assembly, Oil filler cap
Miscellaneous Parts	Tubing, fittings, seals, gaskets, and clamps associated with these listed systems

Note: This list applies to parts supplied by Honda and does not cover parts supplied by the equipment manufacturer. Please see the original equipment manufacturer's emissions warranty for non-Honda parts.

* Covered up to the first required replacement only. See the Maintenance Schedule on page 42.

NOTES

NOTES

NOTES

QUICK REFERENCE INFORMATION

Fuel	Type	Unleaded gasoline with an ethanol content of no more than 10% and a pump octane rating of 86 or higher
Engine Oil	Type	SAE 5W-30 API SJ or later for general use Maximum oil capacity: 1.2 US qt (37 oz, 1.1 L)
Spark Plug	Type	BPR5ES (NGK) W16EPR-U (DENSO)
Tires	Tire Pressure	20 psi (138 kPa)
Maintenance	Before each use, check the following.	Engine oil level. Tire air pressure. Auger skid shoes and scraper. Auger and blower lock bolt. Bolt and nut torque.
	First 20 hours	Change engine oil.
	Subsequent	See Maintenance Schedule (see page 42)

HONDA

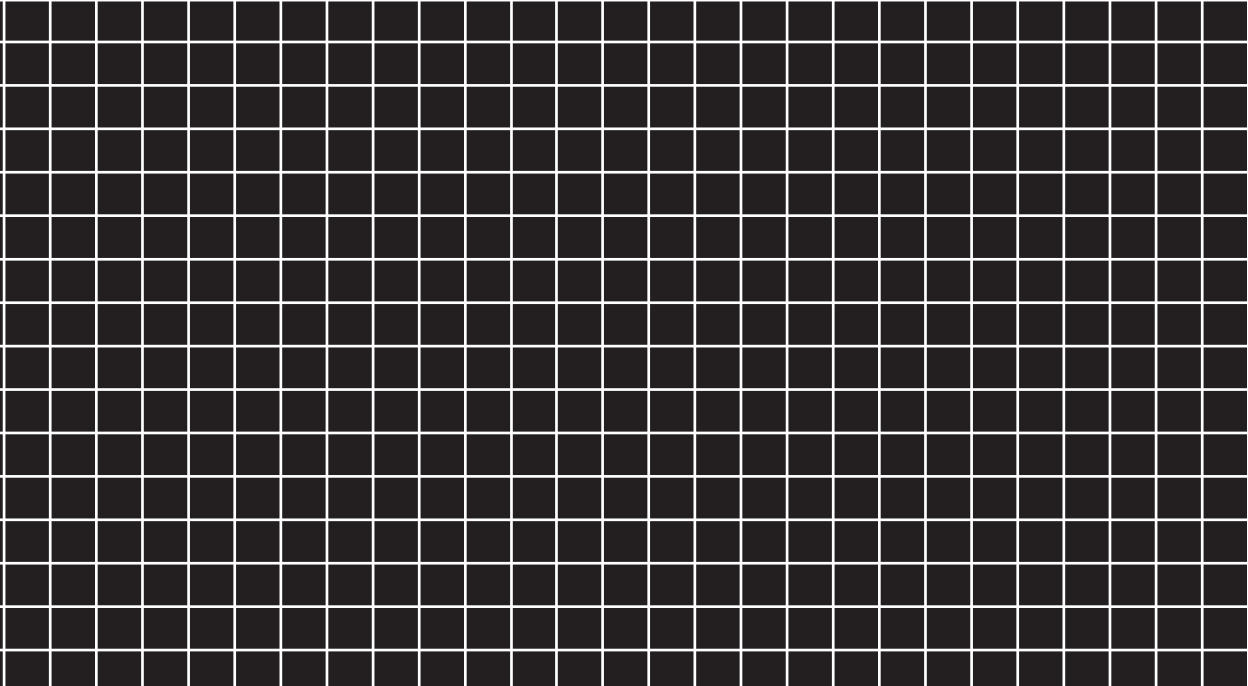

© 2016 American Honda Motor Co., Inc.
—All Rights Reserved

Printed on
Recycled Paper

WAL.5050.2016.08
PRINTED IN U.S.A