

INTRODUCTION

Congratulations on your selection of a Honda snowthrower! We are certain you will be pleased with your purchase of one of the finest snowthrowers on the market.

We want to help you get the best results from your new snowthrower and to operate it safely. This manual contains the information on how to do that; please read it carefully.

We suggest you read the *DISTRIBUTOR'S LIMITED WARRANTY* (page 20) and *EMISSION CONTROL SYSTEM WARRANTY* (page 21) to fully understand coverage and your responsibilities of ownership.

When your snowthrower needs scheduled maintenance, keep in mind that an authorized Honda servicing dealer is specially trained in servicing Honda snowthrowers and is supported by the parts and service divisions of American Honda. Your Honda dealer is dedicated to your satisfaction and will be pleased to answer your questions and concerns.

Keep this owner's manual handy, so you can refer to it at any time. This owner's manual is considered a permanent part of the snowthrower and should remain with the snowthrower if resold.

The information and specifications included in this publication were in effect at the time of approval for printing. American Honda Motor Co., Inc. reserves the right, however, to discontinue or change specifications or design at any time without notice and without incurring any obligation whatever. No part of this publication may be reproduced without written permission.

SAFETY MESSAGES

Your safety and the safety of others are very important. We have provided important safety messages in this manual and on the snowthrower. This information alerts you to potential hazards that could hurt you or others. Please read these messages carefully.

Of course, it is not practical or possible to warn you about all the hazards associated with operating or maintaining a snowthrower. You must use your own good judgment.

You will find important safety information in a variety of forms:

- **Safety Labels** – on the snowthrower.
- **Instructions** – how to use this snowthrower correctly and safely.
- **Safety Messages** – preceded by a safety alert ⚠ symbol and one of three signal words: DANGER, WARNING, or CAUTION. These signal words mean:

⚠ DANGER You WILL be KILLED or SERIOUSLY HURT if you don't follow instructions.

⚠ WARNING You CAN be KILLED or SERIOUSLY HURT if you don't follow instructions.

⚠ CAUTION You CAN be HURT if you don't follow instructions.

Each message tells you what the hazard is, what can happen, and what you can do to avoid or reduce injury.

- **Damage Prevention Messages** – You will also see other important messages that are preceded by the word NOTICE. This word means:

NOTICE Your snowthrower or other property can be damaged if you don't follow instructions.

© 1996–2011 American Honda Motor Co., Inc.—All Rights Reserved

31V10627
00X31-V10-6270



(K0) HS520A
(K1) HS520AS

POM31V10627
HPE.2011.07
PRINTED IN U.S.A.

HONDA

OWNER'S MANUAL HS520A • HS520AS SNOWTHROWER



⚠ WARNING: ⚠

The engine exhaust from this product contains chemicals known to the State of California to cause cancer, birth defects, or other reproductive harm.

CONTENTS

INTRODUCTION.....	1	TRANSPORTING	14
SAFETY MESSAGES.....	1	STORAGE	14
SNOWTHROWER SAFETY	2	TAKING CARE OF UNEXPECTED PROBLEMS.....	16
IMPORTANT SAFETY INFORMATION.....	2	TECHNICAL INFORMATION.....	17
SAFETY LABEL LOCATIONS.....	3	SERIAL NUMBER LOCATIONS	17
SETTING-UP YOUR NEW SNOWTHROWER	3	CARBURETOR	
CONTROL LOCATIONS.....	5	MODIFICATION FOR HIGH ALTITUDE OPERATION.....	17
CONTROLS	6	EMISSION CONTROL SYSTEM	17
BEFORE OPERATION	7	AIR INDEX	18
IS YOUR SNOWTHROWER READY TO GO?.....	7	SPECIFICATIONS	18
OPERATION	8	CONSUMER INFORMATION	19
SAFE OPERATING PRECAUTIONS.....	8	REPLACEMENT PARTS, OPTIONAL EQUIPMENT, AND SERVICE ITEMS.....	19
STARTING THE ENGINE.....	8	DEALER LOCATOR INFORMATION.....	19
STOPPING THE ENGINE	9	CUSTOMER SERVICE INFORMATION	19
CLEARING SNOW	9	DISTRIBUTOR'S LIMITED WARRANTY.....	20
SERVICING YOUR SNOWTHROWER	10	HONDA ACCESSORIES, REPLACEMENT PARTS, AND APPAREL.....	20
MAINTENANCE SAFETY.....	10	EMISSION CONTROL SYSTEM WARRANTY.....	21
MAINTENANCE SCHEDULE	11	PRODUCT REGISTRATION	Last Page
ENGINE MAINTENANCE	12		
AUGER	13		
SCRAPER BLADE.....	13		
REFUELING	11		

SNOWTHROWER SAFETY

IMPORTANT SAFETY INFORMATION

Honda snowthrowers are designed to clear snow from driveways and walkways. Other uses can result in injury to the operator or damage to the snowthrower and other property.

Most injuries and property damage with snowthrowers can be prevented if you follow all instructions in this manual and on the snowthrower. The most common hazards are discussed below, along with the best way to protect yourself and others.

Avoid Rotating Auger

The snowthrower auger can cause serious cuts and even amputate fingers, hands, toes, or feet. Keep away from the auger whenever the engine is running. If you need to work around the snowthrower to clear snow for any reason, always shut off the engine. If the snow discharge chute becomes clogged, stop the engine and disconnect the spark plug cap. Use a wooden stick to remove the obstruction. Never put your hand into the snow discharge chute while the engine is running; serious personal injury could result.

Clear Operation Area

The snowthrower can throw rocks and other objects with enough force to cause serious injury. Before operating the snowthrower, carefully inspect the area and remove all obvious hazards. Never use the snowthrower to clear snow from a gravel road or driveway, as rocks may be picked up and ejected. They may cause injury to bystanders.

Keep Shields in Place

Guards and shields are designed to protect you from being hit by thrown objects and to keep you from touching hot engine parts and moving components. For your safety and the safety of others, keep all shields in place when the engine is running.

Adjust the snow discharge chute to avoid hitting the operator, bystanders, windows, and other objects with ejected snow. Stay clear of the snow discharge chute while the engine is running.

Children and pets must be kept away from the area of operation to avoid injury from flying debris and contact with the snowthrower.

Refuel with Care

Gasoline is extremely flammable, and gasoline vapor can explode. Allow the engine to cool if the snowthrower has been in operation. Refuel only outdoors in a well-ventilated area with the engine OFF. Never fill the fuel tank beyond the maximum fill mark. Never smoke near gasoline, and keep other flames and sparks away. Always store gasoline in an approved container.

Turn Engine Off When Not Operating the Snowthrower

If you need to leave the snowthrower for any reason, even just to inspect the area ahead, always turn the engine off.

Operation on Slopes

To avoid overturning, be careful when changing the direction of the snowthrower while operating it on a slope. Do not use the snowthrower to remove snow from roofs. The snowthrower may overturn on steep slopes if left unattended, causing injury to the operator or bystanders.

Operating Conditions

Do not use the snowthrower when visibility is poor. Under conditions of poor visibility, there is a greater risk of striking an obstacle or causing injury. Adjust the snow discharge chute to avoid hitting passing bystanders or vehicles. Stay clear of the snow discharge chute while the engine is running.

Operating Near Roads

Always watch for vehicle traffic when operating the snowthrower near roads and driveways. Never operate the snowthrower on public roads.

Operator Responsibility

Know how to stop the snowthrower quickly in case of emergency. Understand the use of all snowthrower controls.

Never permit anyone to operate the snowthrower without proper instruction. Do not let children operate the snowthrower. If people or pets suddenly appear in front of the snowthrower while it is in operation, immediately release the auger and drive clutch lever to stop the snowthrower and avoid possible injury from the rotating auger.

While operating the snowthrower, hold the handle firmly, and walk, don't run. Wear suitable winter boots that resist slipping.

Hot Exhaust

The muffler becomes very hot during operation and remains hot for a while after stopping the engine. Be careful not to touch the muffler while it is hot. Let the engine cool before transporting the snowthrower or storing it indoors.

To prevent fire hazards, keep the snowthrower at least 3 feet (1 meter) away from building walls and other equipment during operation. Do not place flammable objects close to the engine.

Carbon Monoxide Hazards

Exhaust contains poisonous carbon monoxide, a colorless and odorless gas. Breathing carbon monoxide can cause loss of consciousness and may lead to death.

Do not run the snowthrower in an area that is enclosed, or even partially enclosed. The air you breathe could contain a dangerous amount of exhaust gas.

Never run the engine inside a garage or confined area.

SAFETY LABEL LOCATIONS

The label shown here contains important safety information. Please read it carefully. This label is considered a permanent part of your snowthrower. So if the label comes off or becomes hard to read, contact your authorized Honda snowthrower dealer for a replacement.

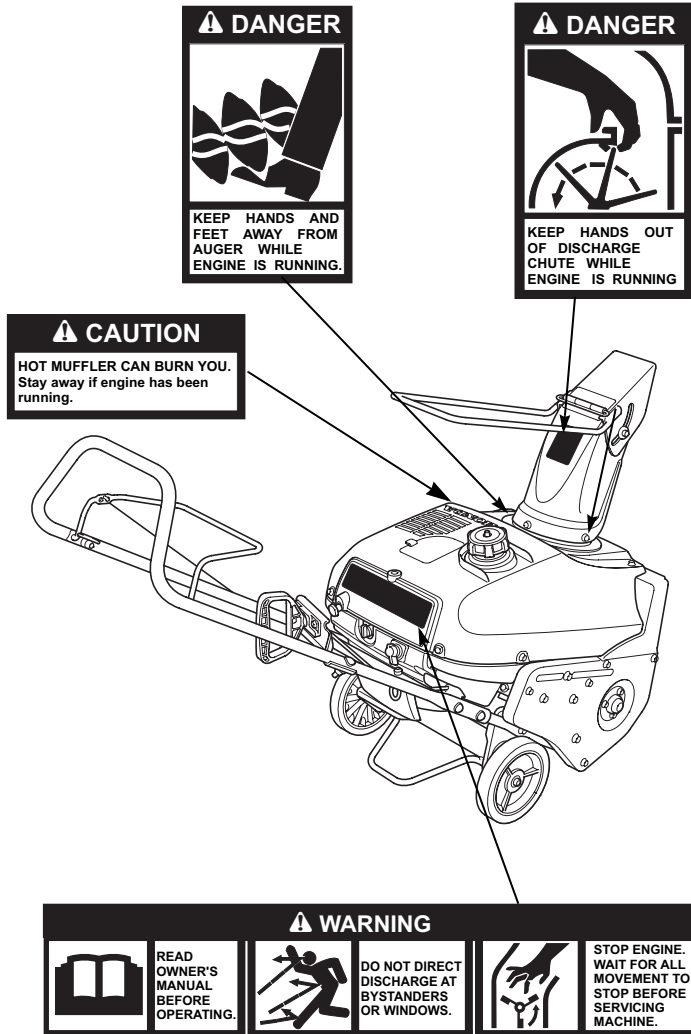

SETTING-UP YOUR NEW SNOWTHROWER

TOOLS REQUIRED

12 mm wrench, 10 mm wrench, and a Phillips screwdriver

UNPACKING

1. Remove all the cardboard. Inspect the loose parts. Missing parts can be obtained from the Honda dealer who sold you the snowthrower.

Qty.	Description	Part number
4	Curved head bolt 8 x 40 mm	90109-VA4-000
4	Flange nut, 8 mm	94050-08000
4	Curved washer, 9 mm	90501-898-000
3	Phillips head shoulder screw 6 x 12 mm	90112-V10-000
3	Flange nut, 6 mm, Nylock	90303-V10-000
2	Cable tie (AS model only)	32901-VB5-A00
2	Key (AS model only)	35110-766-003
1	Honda Genuine oil	08207-5W30

2. Loosen and remove the curved-head bolt, flange nut, and starter bracket from the lower handlebar. Do not discard the hardware.

ASSEMBLY

1. Install the handlebar with the hardware shown. Tighten the flange nuts securely.

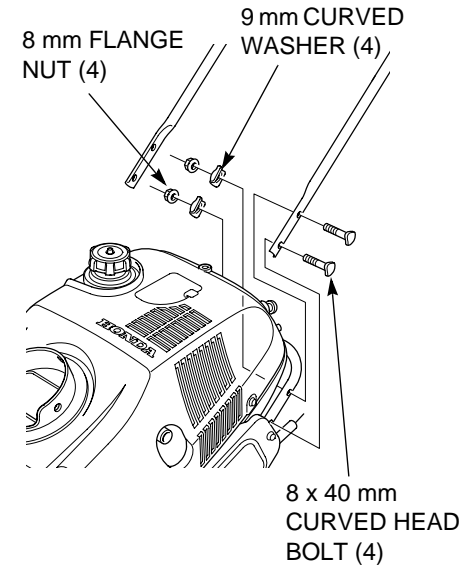

2. Pull the clutch cable enough to insert the "Z" fitting on the cable through the auger clutch lever as shown here. Check the lever free play as shown on [page 13](#).

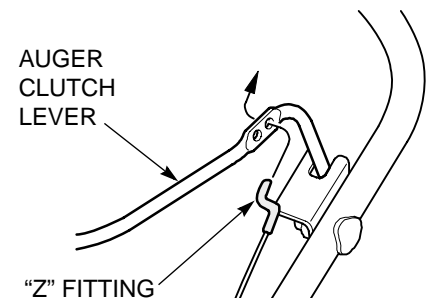

3. Install the starter bracket using the hardware removed from step 2 on the previous page. For the HS520AS, snap the starter rope into the rope guide on the handlebar and secure the electric start wire using the two cable ties as shown. Trim the cable ties to a length of 3/8 inch (10 mm).

HS520A

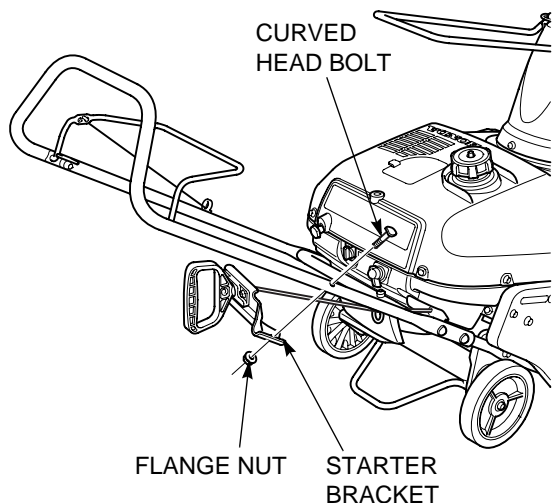

HS520AS

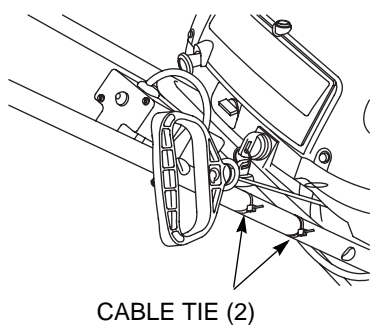
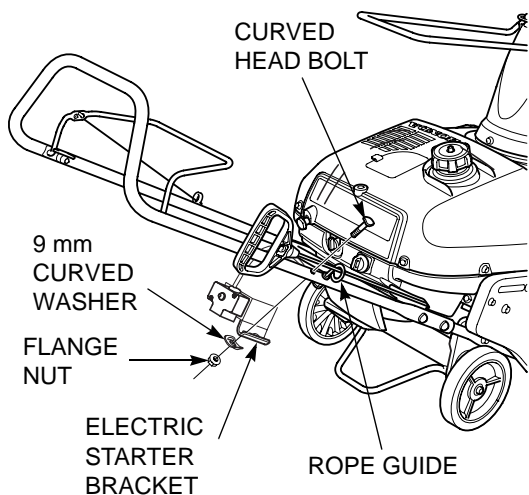

4. Install the discharge chute using the three 6 mm Phillips-head screws and 6 mm self-locking nuts. Make sure the screws go on the inside and the nuts on the outside. **Tighten the nuts securely: HEX NUT TORQUE: 7 ft-lbs (10 N•m)**

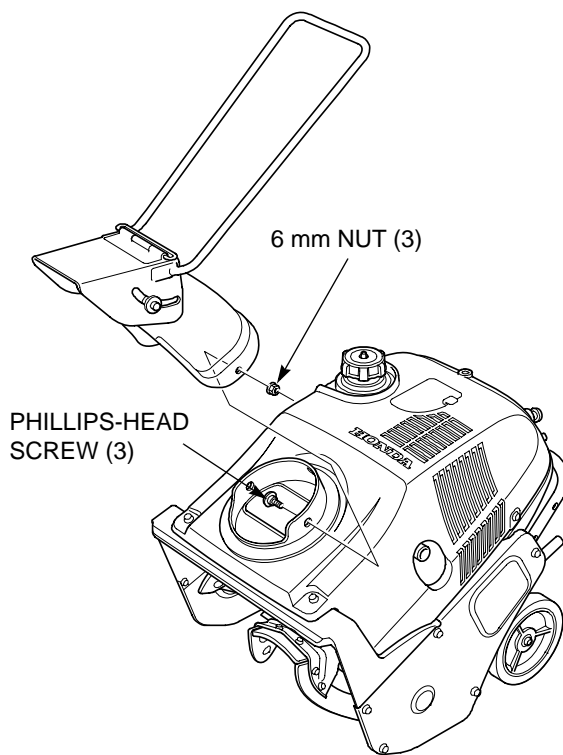
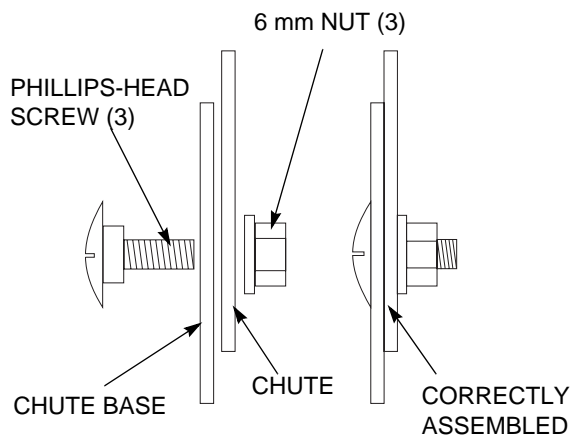

5. Lift the spark plug door and attach the spark plug cap to the spark plug.

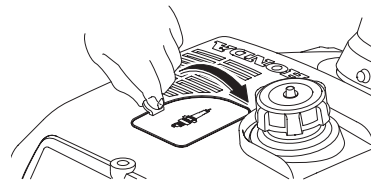

6. Remove any packing material from the side of the snowthrower.

ADD OIL & FUEL

1. The snowthrower is shipped **WITHOUT OIL** in the engine.
2. Add enough of the recommended oil ([page 12](#)) to bring the oil level to the top of the filler hole. A bottle of oil is included in the box with your snowthrower.

All Honda engines are run at the factory prior to packaging. Most of the oil is removed prior to shipment; however, some oil remains in the engine. The amount of oil left in the engine varies.

3. Add regular unleaded fuel to the fuel tank. The fuel capacity is 1.37 US quarts (1.3 liters). See [page 11](#).

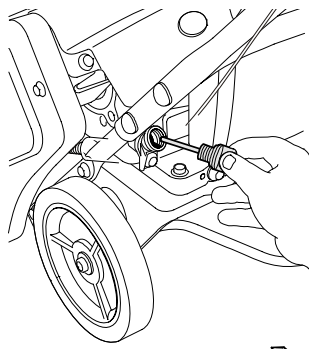

UPPER LIMIT

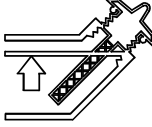

CONTROL LOCATIONS

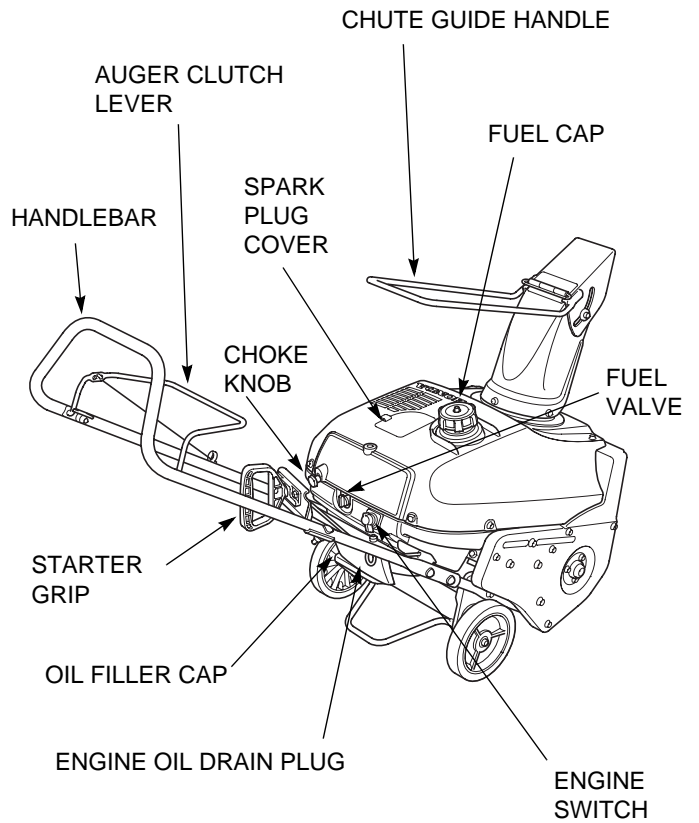

HS520AS

STARTER
BUTTON
(P. 8)

A small inset diagram showing a close-up of the starter button on the HS520AS model, with an arrow pointing to it.

BEFORE USE

All operators of the snowthrower must read the following chapters before using the snowthrower:

SNOWTHROWER SAFETY ([page 2](#))

CONTROLS ([page 6](#))

BEFORE OPERATION ([page 7](#))

OPERATION ([page 8](#))

MAINTENANCE SCHEDULE ([page 11](#))

CONTROLS

Fuel Valve

The fuel valve opens and closes the fuel line leading from the fuel tank to the carburetor. Make sure that the fuel valve is positioned exactly at either the ON or OFF position. When the snowthrower is not in use, always leave the fuel valve in the OFF position to reduce the possibility of fuel leakage.

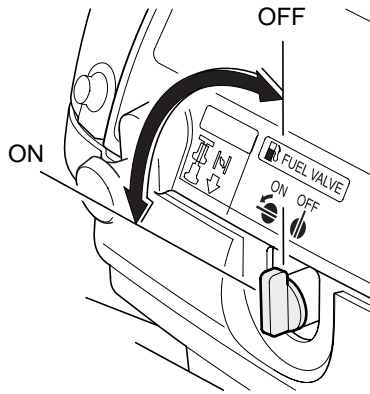

Engine Switch

The engine switch controls the ignition system. The HS520A has an OFF-ON-OFF switch, while the HS520AS has a key that controls an OFF-ON switch.

OFF — Stops the engine.
ON — Running position, and for starting with the recoil or electric starter button (HS520AS).

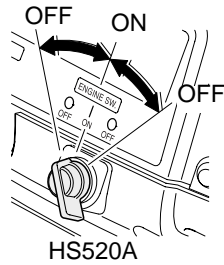

HS520A

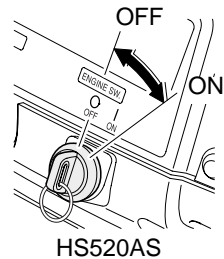

HS520AS

Starter Button (HS520AS)

The starter button is used to operate the electric starter when a household extension cord is plugged into the starter box.

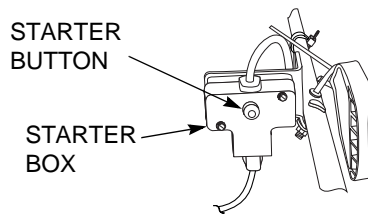

Starter Grip

Pull this grip to start the engine.

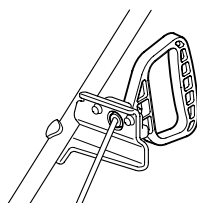

Choke Knob

The choke knob is used to open or close the choke. CLOSED is used when the engine is cold.

The OPEN position provides the correct fuel mixture for operation after the engine has warmed up, and for starting a warm engine.

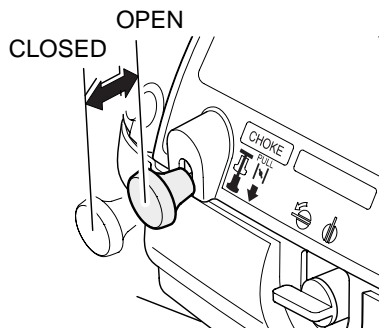

Chute Guide Handle

Use this control to guide the snow discharge angle and direction.

LOW AND NEAR

HIGH AND FAR

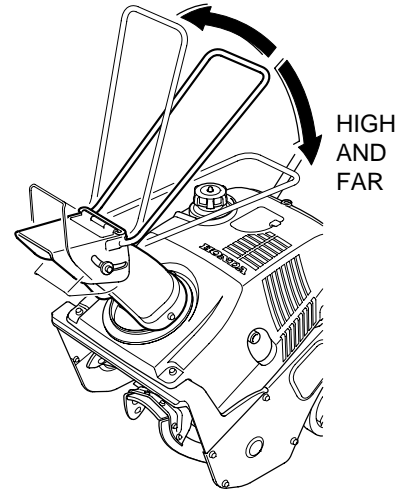

LEFT

RIGHT

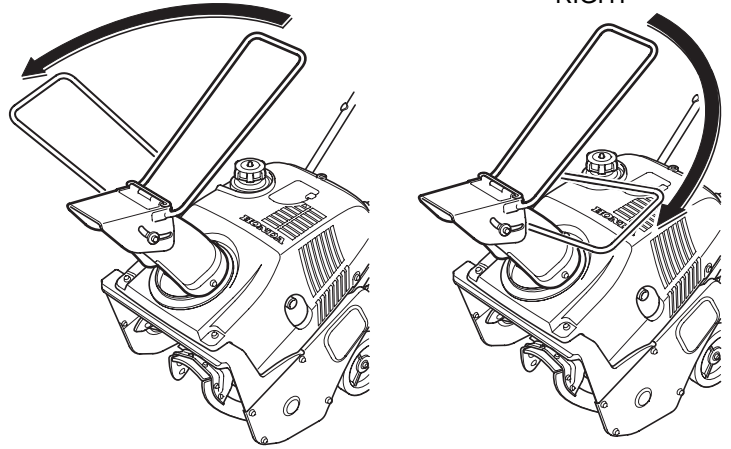

Auger Clutch Lever

When this lever is engaged, the snowthrower auger paddles begin to spin and the snowthrower will move forward.

Do not engage the auger clutch lever on cleared ground or the snowthrower will move forward suddenly.

ENGAGE

RELEASE

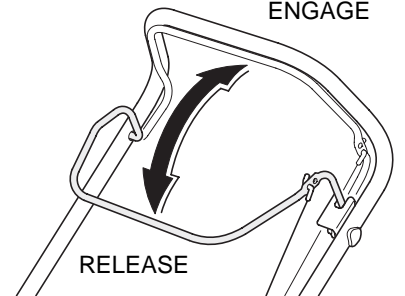

BEFORE OPERATION

Your safety is your responsibility. A little time spent in preparation will significantly reduce your risk of injury.

Read and understand this manual. Know what the controls do and how to operate them.

Familiarize yourself with the snowthrower and its operation before you begin using it. Know how to quickly shut off the engine in case of an emergency.

IS YOUR SNOWTHROWER READY TO GO?

For your safety, and to maximize the service life of your equipment, it is very important to take a few moments before you operate the snowthrower to check its condition. Be sure to take care of any problem you find, or have your servicing dealer correct it, before you operate the snowthrower.

⚠ WARNING

Improperly maintaining this snowthrower, or failing to correct a problem before operation, could cause a malfunction in which you could be seriously injured.

Always perform a pre-operation inspection before each operation, and correct any problem.

Before beginning your pre-operation checks, be sure the snowthrower is on a level surface and the engine switch is in the OFF position.

Check the General Condition of the Snowthrower

- Look around and underneath the snowthrower for signs of oil or gasoline leaks.
- Check the auger housing and the discharge chute for accumulation of packed snow or ice. Clean the auger housing and discharge chute before starting the snowthrower.
- Check each control for proper operation.
- Check auger paddles for wear. Replace if necessary.
- Check the scraper blade for wear. Replace if necessary ([page 14](#)).
- Look for signs of damage.
- Check that all nuts, bolts, screws, hose connectors, and clamps are tightened.
- Keep all shields and covers in place while operating the snowthrower.

Check the Engine

- Check the oil level ([page 12](#)).
- Check the fuel level ([page 11](#)). Starting with a full tank will help to eliminate or reduce operating interruptions for refueling.

CHECK YOUR WORK AREA

For your safety and the safety of others, always inspect the area before operating the snowthrower.

Objects

Anything which can be picked up by the auger and thrown is a potential hazard to you and others. Look for hazards and remove them from the work area.

People and Pets

People and animals near the work area can move into your snowthrower's path or into a position where they could be struck by thrown objects. Clear the area of people, especially children and pets. Their safety is your responsibility.

Work Area

Check the condition of the snow. Adjust your snowthrower ground speed and snowblowing swath accordingly.

Check the scraper blade for proper adjustment. Check the scraper blade for the correct auger ground clearance ([page 9](#)).

OPERATION

SAFE OPERATING PRECAUTIONS

Before operating the snowthrower for the first time, please review both the *SNOWTHROWER SAFETY* chapter (page 2) and the *BEFORE OPERATION* chapter above.

Even if you have operated other snowthrowers, take time to become familiar with how this snowthrower works, and practice in a safe area until you build up your skills.

Never tamper with or alter any of the controls or safety devices on the snowthrower.

Do not operate on slopes greater than 20°.

For your safety, do not operate the engine in an enclosed area such as a garage. Your snowthrower's exhaust contains poisonous carbon monoxide gas which can collect rapidly in an enclosed area and cause illness or death.

WARNING

Engine exhaust contains poisonous carbon monoxide gas that can build up to dangerous levels in closed areas. Breathing carbon monoxide can cause unconsciousness and death.

Never run the snowthrower in a closed or even partly closed area.

STARTING THE ENGINE

1. Turn the fuel valve to the ON position.

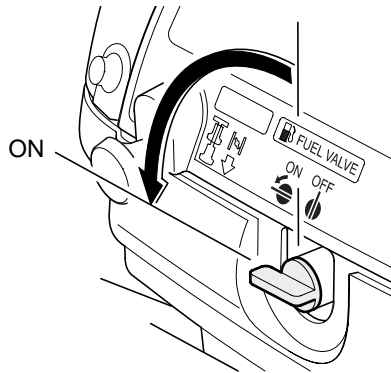

2. If the engine is cold, pull the choke knob out to the CLOSED position.

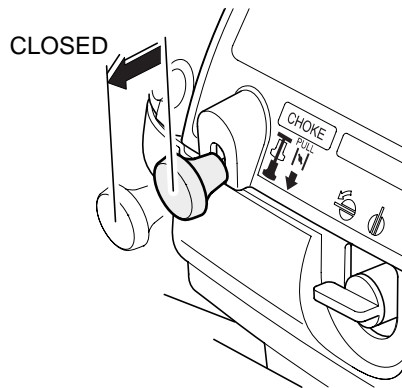

3. Start the engine.
Electric Start (AS model only):

- a. Connect an extension cord (commercially available) to the starter box first, and then to a 120 volt ac outlet.

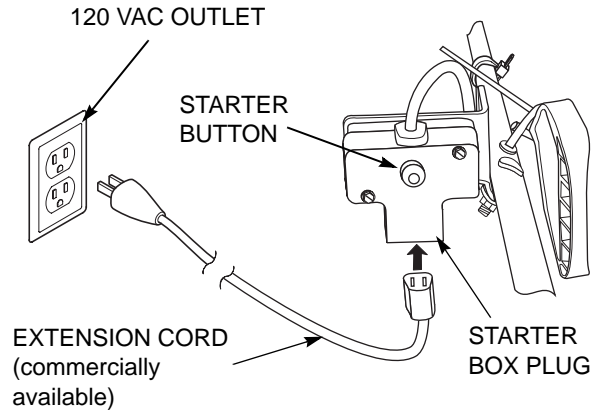

Use an outdoor power cord with a power rating of no less than 15 amps. Do not connect and disconnect the power cord with wet hands. Do not use in the rain.

Be sure to hold the plug when disconnecting the power cord from the electrical outlet or starter box. Do not disconnect by pulling on the power cord.

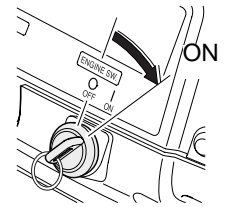

- b. Turn the engine switch to the ON position.
- c. Push the starter button until the engine starts. After the engine starts, disconnect the power cord from the electrical outlet, and then from the starter box.

NOTICE

To prevent damage to the starter, do not operate the starter for more than 15 seconds. If the engine fails to start, release the button and allow the starter to cool for 10 minutes before operating it again.

Manual (Pull) Starting

- a. Turn the engine switch to the ON position.

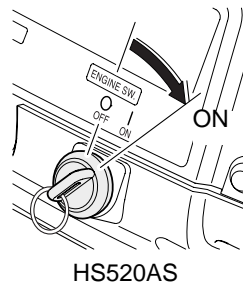
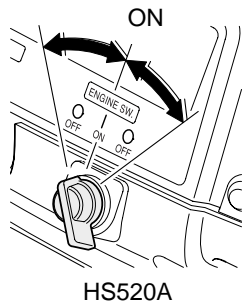

- b. Pull the starter grip slowly until you feel resistance, and then pull briskly.
- c. Return the starter grip gently.

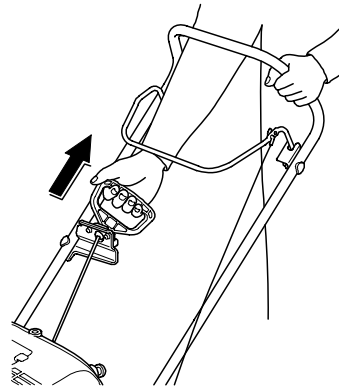

NOTICE

To prevent damage to the recoil starter, do not allow the starter grip to snap back against the starter bracket. Return it gently to prevent damage. Do not pull the starter grip while the engine is running. The starter could be damaged.

4. Let the engine warm up for several minutes. If the choke knob has been pulled to the CLOSED position to start the engine, gradually push it to the OPEN position as the engine warms up.

STOPPING THE ENGINE

To stop the engine in an emergency, turn the engine switch to the OFF position. Under normal conditions, use the following procedure.

1. Release the auger clutch lever. The auger will stop operation.

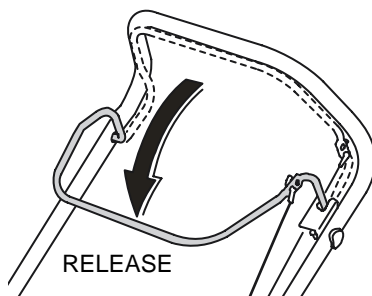

2. Turn the engine switch to the OFF position.

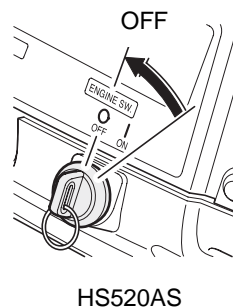
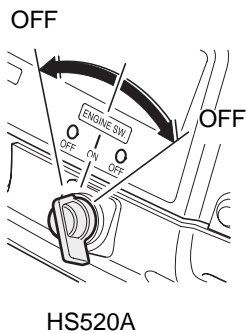

3. Turn the fuel valve to the OFF position.

CLEARING SNOW

1. Press down on the handlebar to raise the front of the snowthrower slightly. Roll the snowthrower over to the area to be cleared.
2. Use the chute guide handle (page 6) to adjust the direction for the discharged snow to travel.
3. Engage the auger clutch lever. The auger will begin to spin.
4. Tilt the snowthrower forward slightly with the handlebar to engage the auger into the snow. The auger will then pull the snowthrower forward and discharge the snow.

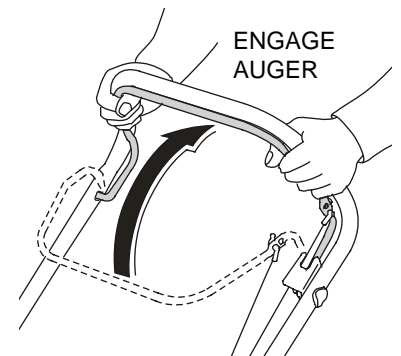

TILT FORWARD SLIGHTLY

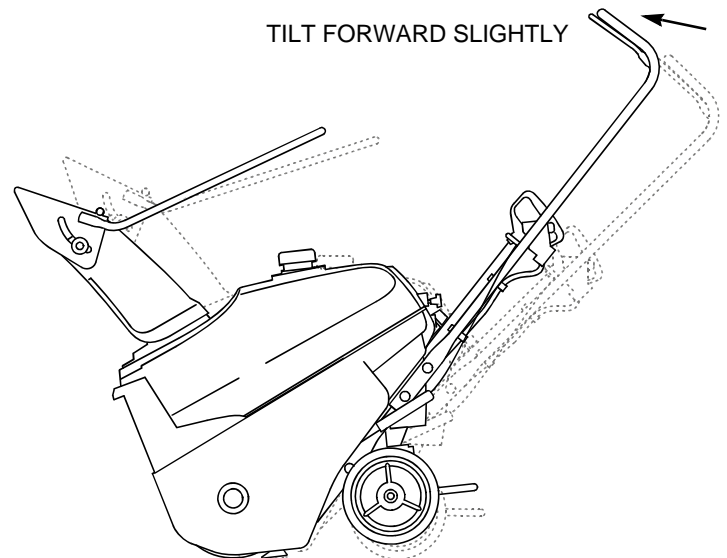

5. To stop, lower the handlebar slightly, and then release the auger clutch lever.

SNOW-CLEARING TIPS

For best efficiency, clear snow before it melts, refreezes and hardens. Operating tips for clearing hard or deep snow:

- Clear snow with a back and forth motion. Release the auger clutch lever, and then press down on the handlebar to raise the auger housing when pulling the snowthrower backwards.
- Clear a narrower swath. Make several passes with the auger overlapping the cleared areas.

REMOVING OBSTRUCTIONS

If the discharge chute or snowthrowing mechanism becomes restricted:

1. Stop the engine.
2. Make sure that all rotating parts have come to a complete stop.
3. Remove the spark plug cap from the spark plug (page 12).
4. Use a wooden stick to clear the obstruction.

SERVICING YOUR SNOWTHROWER

Proper maintenance is essential for safe, economical, and trouble-free operation. It will also help reduce air pollution.

WARNING

Improper maintenance, or failure to correct a problem before operation, can cause a malfunction in which you can be seriously hurt or killed.

Always follow the inspection and maintenance recommendations and schedules in this owner's manual.

To help you properly care for your snowthrower, the following pages include a maintenance schedule, routine inspection procedures, and simple maintenance procedures using basic hand tools. Other service tasks that are more difficult, or require special tools, are best handled by professionals and are normally performed by a Honda technician or other qualified mechanic.

The maintenance schedule applies to normal operating conditions. If you operate your snowthrower under severe conditions, such as sustained high-load or high-temperature operation, or use in unusually wet or dusty conditions, consult your servicing dealer for recommendations applicable to your individual needs and use.

Remember that an authorized Honda servicing dealer knows your snowthrower best and is fully equipped to maintain and repair it.

To ensure the best quality and reliability, use only new, Honda Genuine parts or their equivalents for repair and replacement.

Maintenance, replacement, or repair of the emission control devices and systems may be performed by any engine repair establishment or individual, using parts that are "certified" to EPA standards.

MAINTENANCE SAFETY

Some of the most important safety precautions follow. However, we cannot warn you of every conceivable hazard that can arise in performing maintenance. Only you can decide whether or not you should perform a given task.

WARNING

Failure to properly follow maintenance instructions and precautions can cause you to be seriously hurt or killed.

Always follow the procedures and precautions in this owner's manual.

Safety Precautions

- Make sure the engine is off before you begin any maintenance or repairs. This will eliminate several potential hazards:
 - **Carbon monoxide poisoning from engine exhaust.**
Operate outdoors away from open windows or doors.
 - **Burns from hot parts.**
Let the engine and exhaust system cool before touching.
 - **Injury from moving parts.**
Do not run the engine unless instructed to do so.
- Read the instructions before you begin, and make sure you have the tools and skills required.
- To reduce the possibility of fire or explosion, be careful when working around gasoline. Use only a nonflammable solvent, not gasoline, to clean parts. Keep cigarettes, sparks, and flames away from all fuel-related parts.

MAINTENANCE SCHEDULE

Interval ¹	Item	Page
Before each use	Check the engine oil level Check the scraper blade	page 12 page 13
First month or 25 hours	Change the engine oil	page 12
Every year - Before operation	Change the engine oil Check/adjust the spark plug Check auger clutch lever freeplay Check auger paddles Check/adjust the scraper blade	page 12 page 12 page 13 page 13 page 13
Every year - Before storage	Check/adjust the spark plug Drain the fuel tank/carburetor Apply oil/grease to moving parts	page 12 page 15 page 15
Every 100 hours	Check/adjust the spark plug Adjust the engine speed ² Adjust the valve clearance ²	page 12
Every 150 hours	Replace the spark plug Clean the fuel tank and fuel filter ²	page 12
Every 2 years	Check the fuel line and replace if necessary ²	

- For professional commercial use, log hours of operation to determine proper maintenance intervals.
- These items should be serviced by an authorized Honda servicing dealer, unless you have the proper tools and are mechanically proficient. Refer to the Honda shop manual for service procedures. See "Honda Publications" on [page 19](#) for ordering information.
Failure to follow this maintenance schedule could result in non-warrantable failures.

REFUELING

Honda recommends using a No-Spill[®] gas can, which meets the demanding requirements of the California Air Resources Board ([page 19](#)).

This engine is certified to operate on unleaded gasoline with a pump octane rating of 86 or higher.

Refuel in a well-ventilated area with the engine stopped. If the engine has been running, allow it to cool first. Never refuel the engine inside a building where gasoline fumes may reach flames or sparks.

You may use regular unleaded gasoline containing no more than 10% ethanol (E10) or 5% methanol by volume. In addition, methanol must contain cosolvents and corrosion inhibitors. Use of fuels with content of ethanol or methanol greater than shown above may cause starting and/or performance problems. It may also damage metal, rubber, and plastic parts of the fuel system. Engine damage or performance problems that result from using a fuel with percentages of ethanol or methanol greater than shown above are not covered by warranty.

If your equipment will be used on an infrequent or intermittent basis, please refer to the fuel section of the *STORAGE* chapter ([page 14](#)) for additional information regarding fuel deterioration.

⚠ WARNING

Gasoline is highly flammable and explosive.

You can be burned or seriously injured when handling fuel.

- Stop the engine and keep heat, sparks, and flame away.
- Handle fuel only outdoors.
- Wipe up spills immediately.

Never use stale or contaminated gasoline or an oil/gasoline mixture. Avoid getting dirt or water in the fuel tank.

To refuel, remove the fuel tank cap, and fill the tank with gasoline to the shoulder of the filler neck. Refuel carefully to avoid spilling fuel. Do not overfill.

After refueling, tighten the fuel tank cap securely.

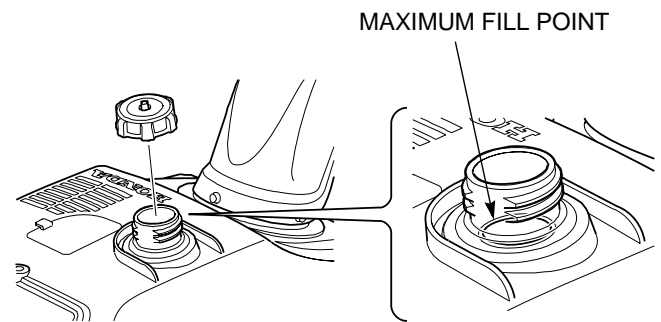

Move the snowthrower at least 10 feet (3 meters) away from the fueling source and site before starting the engine.

NOTICE

Fuel can damage paint and plastic. Be careful not to spill fuel when filling your fuel tank. Damage caused by spilled fuel is not covered by the DISTRIBUTOR'S LIMITED WARRANTY ([page 20](#)).

ENGINE MAINTENANCE

Engine Oil

Oil Level Check

Check the engine oil level with the snowthrower stopped and in a level position.

1. Remove the oil filler cap/dipstick and wipe it clean.
2. Insert and remove the dipstick without screwing it into the filler neck.
3. If the level is low, fill to the edge of the oil filler hole with the recommended oil (page 12).
4. Reinstall the oil filler cap/dipstick.

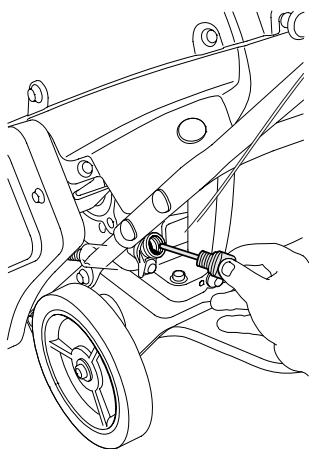

NOTICE

Running the engine with a low oil level can cause engine damage.

UPPER LIMIT

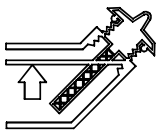

Engine Oil Change

Drain the oil while the engine is still warm to assure rapid and complete draining.

1. Place the snowthrower on a level surface.
2. Place a suitable container below the drain bolt to catch the used oil, and then remove the oil filler cap/dipstick and the drain plug.
3. Allow the used oil to drain completely, and then reinstall the drain plug, and tighten it securely.

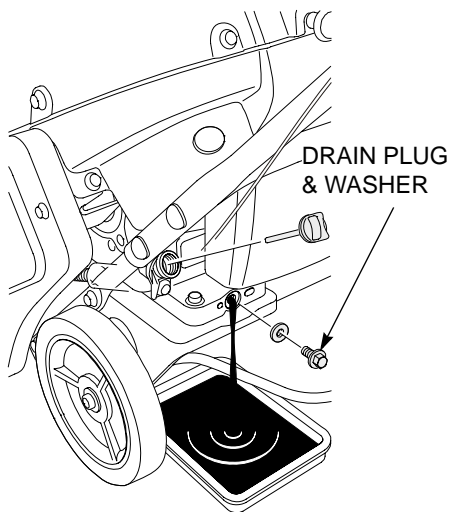

NOTICE

Improper disposal of engine oil can be harmful to the environment. If you change your own oil, please dispose of used motor oil properly. Put it in a sealed container and take it to a recycling center. Do not throw it in the trash; do not pour it on the ground or down a drain.

4. With the engine in a level position, fill to the outer edge of the oil filler hole with the recommended oil (page 12).

NOTICE

Running the engine with a low oil level can cause engine damage. This type of damage is not covered under the DISTRIBUTOR'S LIMITED WARRANTY.

5. Screw in the oil filler cap/dipstick securely.

Engine Oil Recommendations

Oil is a major factor affecting performance and service life. Use a high quality 4-stroke automotive detergent oil.

SAE 5W-30 is recommended for general use. Other viscosities shown in the chart may be used when the average temperature in your area is within the indicated range. The SAE oil viscosity and service classification are on the API label on the oil container.

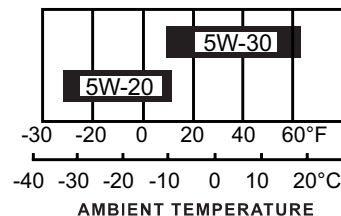

Honda recommends that you use API service category SJ (or later) oil or equivalent.

Spark Plug Service

To ensure proper engine operation, the spark plug must be properly gapped and free of deposits.

1. Open the spark plug access panel, and then remove the spark plug cap. Use a commercially available spark plug wrench or socket to remove the spark plug.
2. Inspect the spark plug. Replace it if the electrodes are worn or if the insulator is cracked, chipped, or fouled with deposits. Make sure that the spark plug washer is in good condition.

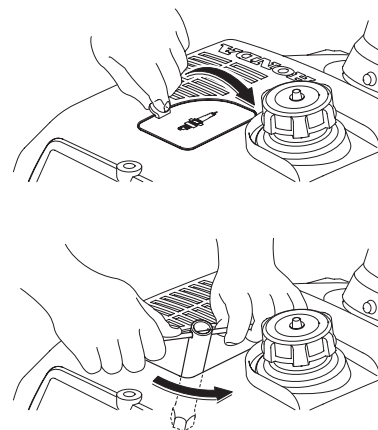

NOTICE

Use only the recommended spark plugs or equivalent. Spark plugs that have an improper heat range may cause engine damage.

A replacement spark plug may be purchased from a servicing Honda snowthrower dealer. See page 19 for a part number list.

SPARK PLUG: BPR5ES (NGK) or W16EPR-U (DENSO)

3. Measure the plug gap with a feeler gauge. Correct as necessary by bending the side electrode.

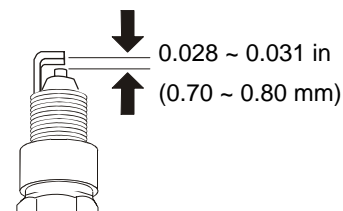

PLUG GAP: 0.028 ~ 0.031 inch (0.70 ~ 0.80 mm)

4. Thread the spark plug in by hand to prevent cross-threading.
5. After the spark plug is seated, tighten with a spark plug wrench to compress the washer.

If installing a new spark plug, tighten 1/2 turn after the spark plug seats to compress the washer. If reinstalling a used spark plug, tighten 1/8 to 1/4 turn after the spark plug seats.

NOTICE

The spark plug must be securely tightened. An improperly tightened spark plug can become hot and may damage the engine.

6. Connect the spark plug cap and close the spark plug access panel.

AUGER

Clutch Lever Free Play

Inspection

1. Move the clutch lever until you feel resistance from the cable. Measure the distance as shown.

CLUTCH LEVER DISTANCE:
7-1/2 ~ 8 inches
(190 ~ 205 mm)

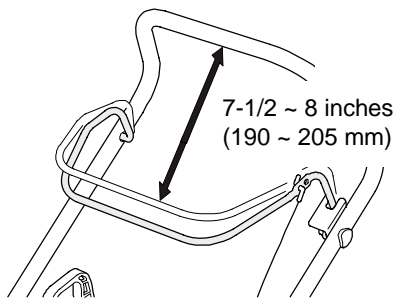

Adjustment

1. Pull the spring cover up to expose the tension spring. Change the position of either the cable or spring on the metal plate so the clutch lever distance is correct.

Moving the spring makes a 1/4 inch (6 mm) change, while moving the cable makes a 3/8 inch (10 mm) change in the length of the cable.

2. Slide the cover back over the spring.

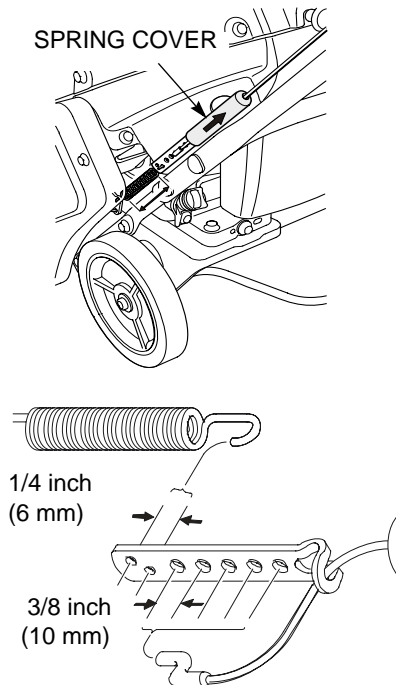

Auger Paddle Inspection

The paddles are thick, rubber parts bolted to the edges of the auger. The paddles are subject to wear, and should be inspected and replaced if worn beyond the service limit.

1. Park the snowthrower on a flat, level surface. Disconnect the spark plug cap and turn the fuel valve OFF so the engine cannot be accidentally started. Tilt the snowthrower back enough to raise the auger housing.
2. Inspect the paddles on the auger and make sure they are in good condition and securely attached.
3. Measure the distance between the edge of the rubber paddle to the edge of the metal auger support.

AUGER PADDLE SERVICE LIMIT:
5/8 inch (15 mm)

Auger paddle replacement should only be done by a servicing Honda snowthrower dealer. If the paddles are worn out, the scraper blade may also need replacement (page 14).

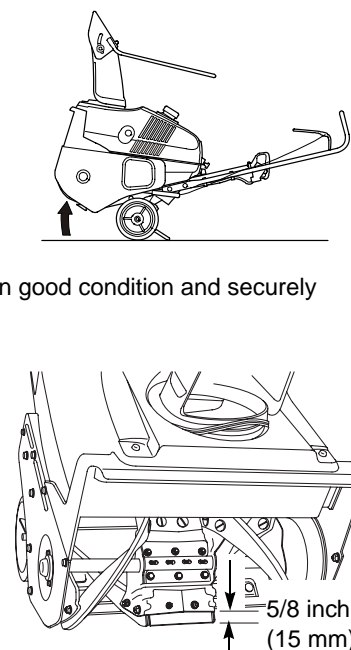

SCRAPER BLADE

The scraper blade wears with normal use and must be replaced when it reaches its service limit. The scraper blade thickness and adjustment determine the clearance between the rubber paddles and the ground.

Inspection

1. Turn the engine switch and fuel valve to the OFF position and disconnect the spark plug cap so the engine cannot be accidentally started.
2. Examine the scraper blade and verify it contacts the ground evenly. If it does not, adjust the scraper blade. See "Scraper blade adjustment" below.
3. Measure the distance between the ground and lowest point on the rubber paddle on the auger. The paddle ground clearance should be 1/16 ~ 1/8 inches (1 ~ 3 mm).

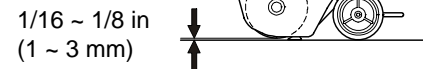

If the ground clearance is not within the specification, adjust the scraper blade. See "Scraper blade adjustment" below.

4. Tilt the snowthrower back and measure the thickness of the scraper blade. Replace the scraper blade if it is less than 1/16 inch (2 mm) thick. See "Scraper blade replacement" on this page.

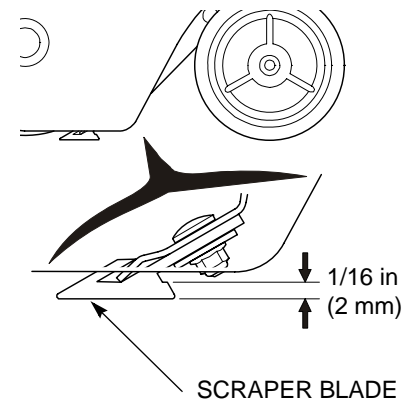

Scraper blade adjustment

1. Turn the engine switch and fuel valve to the OFF position and disconnect the spark plug cap so the engine cannot be accidentally started.
2. Tilt the snowthrower forward to provide access the underside of the scraper blade.
3. Loosen (don't remove) the three flange nuts on the scraper blade.
4. Move the scraper blade down slightly. Tighten the self-locking nuts and recheck the clearance.

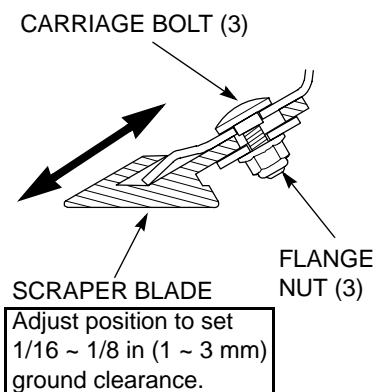

Repeat the procedure as needed to get the necessary clearance. If you cannot set the ground clearance within 1/8 ~ 1/16 inch, replace the scraper blade.

Scraper blade replacement

A new scraper blade can be purchased from a servicing Honda dealer. See [page 19](#) for scraper blade and hardware part numbers.

1. Turn the engine switch and fuel valve to the OFF position ([page 6](#)) and disconnect the spark plug cap so the engine cannot be accidentally started.
2. Tilt the snowthrower forward to provide access the underside of the scraper blade.
3. Remove the three flange nuts, flat washers, and the scraper blade.
4. Install the new scraper blade, reusing the bolts, washers, and nuts.
5. Adjust the scraper blade. See "Scraper blade adjustment" on previous page.

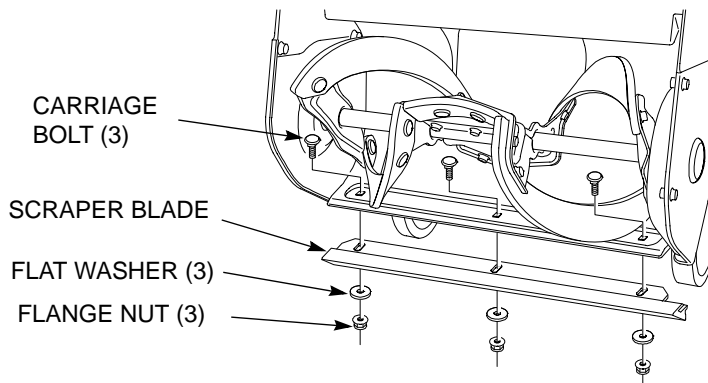

TRANSPORTING

BEFORE LOADING

If the engine has been running, allow it to cool for at least 15 minutes before loading the snowthrower on the transport vehicle. A hot engine and exhaust system can burn you and can ignite some materials.

Turn the fuel valve to OFF. This will prevent carburetor flooding and reduce the possibility of fuel leakage.

Avoid removing any parts from the snowthrower before transport, unless you are mechanically proficient, have the right tools, and follow the procedures in the *HS520 Shop Manual*.

LOADING AND UNLOADING

If a suitable loading ramp is not available, two people should lift the snowthrower on and off the transport vehicle while holding the snowthrower level.

Position the snowthrower so both wheels and the auger box are on the bed of the transport vehicle. Tie the snowthrower down with rope or straps, and block the wheels. Keep the tie-down rope or straps away from the auger drive clutch lever and cable.

STORAGE

STORAGE PREPARATION

Proper storage preparation is essential for keeping your snowthrower trouble-free and looking good. The following steps will help to keep rust and corrosion from impairing your snowthrower's function and appearance, and will make the engine easier to start when you use the snowthrower again.

Cleaning

1. Rinse the auger housing and wheels with a garden hose. Wipe the rest of the snowthrower with a moist rag.
2. After the snowthrower has dried, touch up any damaged paint.

Fuel

NOTICE

Depending on the region where you operate your equipment, fuel formulations may deteriorate and oxidize rapidly. Fuel deterioration and oxidation can occur in as little as 30 days and may cause damage to the carburetor and/or fuel system. Please check with your servicing dealer for local storage recommendations.

Gasoline will oxidize and deteriorate in storage. Old gasoline will cause hard starting, and it leaves gum deposits that clog the fuel system. If the gasoline in your engine deteriorates during storage, you may need to have the carburetor and other fuel system components serviced or replaced.

The length of time that gasoline can be left in your fuel tank and carburetor without causing functional problems will vary with such factors as gasoline blend, your storage temperatures, and whether the fuel tank is partially or completely filled. The air in a partially filled fuel tank promotes fuel deterioration. Very warm storage temperatures accelerate fuel deterioration. Fuel deterioration problems may occur within a few months, or even less if the gasoline was not fresh when you filled the fuel tank.

The *DISTRIBUTOR'S LIMITED WARRANTY* does not cover fuel system damage or engine performance problems resulting from neglected storage preparation.

You can extend fuel storage life by adding a fuel stabilizer that is formulated for that purpose, or you can avoid fuel deterioration problems by draining the fuel tank and carburetor.

Adding Fuel Stabilizer to Extend Fuel Storage Life

When adding a fuel stabilizer, fill the fuel tank with fresh gasoline. If only partially filled, air in the tank will promote fuel deterioration during storage. If you keep a container of gasoline for refueling, be sure that it contains only fresh gasoline.

1. Add fuel stabilizer following the manufacturer's instructions.
2. After adding a fuel stabilizer, run the engine outdoors for 10 minutes to be sure that treated gasoline has replaced the untreated gasoline in the fuel system.
3. Turn the fuel valve to the OFF position ([page 6](#)).
4. Continue to run the engine until it stops from the lack of fuel in the carburetor fuel bowl. Running time should be less than 3 minutes.

Draining the Fuel Tank and Carburetor

⚠ WARNING

Gasoline is highly flammable and explosive.

You can be burned or seriously injured when handling fuel.

- Stop the engine and keep heat, sparks, and flames away.
- Handle fuel only outdoors.
- Wipe up spills immediately.

1. Place an approved gasoline container below the carburetor drain tube, and use a funnel to avoid spilling fuel. Turn the fuel valve to the ON position.
2. Locate the carburetor drain screw in the access hole on the left rear side.

DRAIN SCREW

Located inside the shroud 3-3/4 inches.

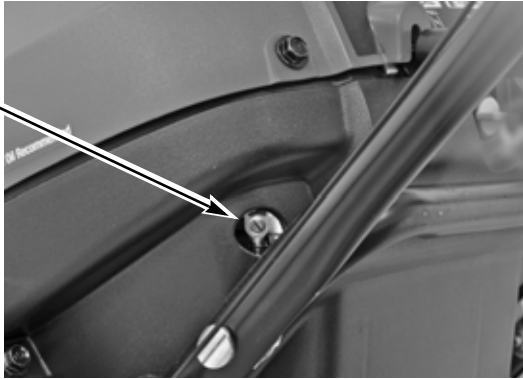

It helps to hold a flashlight under the snowthrower between the shroud and engine shinning up to the carburetor bowl.

3. Use a long, flat-tip screwdriver to loosen (don't remove) the drain screw until fuel starts to drain.

Drain until the fuel tank is empty, and then tighten the drain screw.

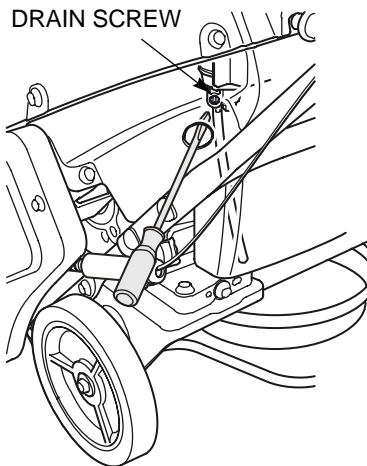

Engine Oil

1. Change the engine oil ([page 12](#)).
2. Remove the spark plug ([page 12](#)).
3. Pour 1 - 2 teaspoons (5 ~ 10 cc) of clean engine oil into the cylinder.
4. Pull the starter rope slowly several times to distribute the oil.
5. Inspect, adjust, and reinstall the spark plug ([page 12](#)).
6. Pull the starter grip until resistance is felt. This will close the valves and protect the engine from internal corrosion.

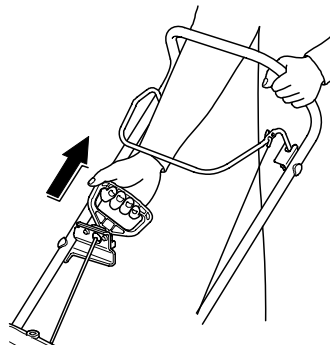

Lubrication

Apply a few drops of oil or a small amount of grease to the following parts for lubrication and rust prevention.

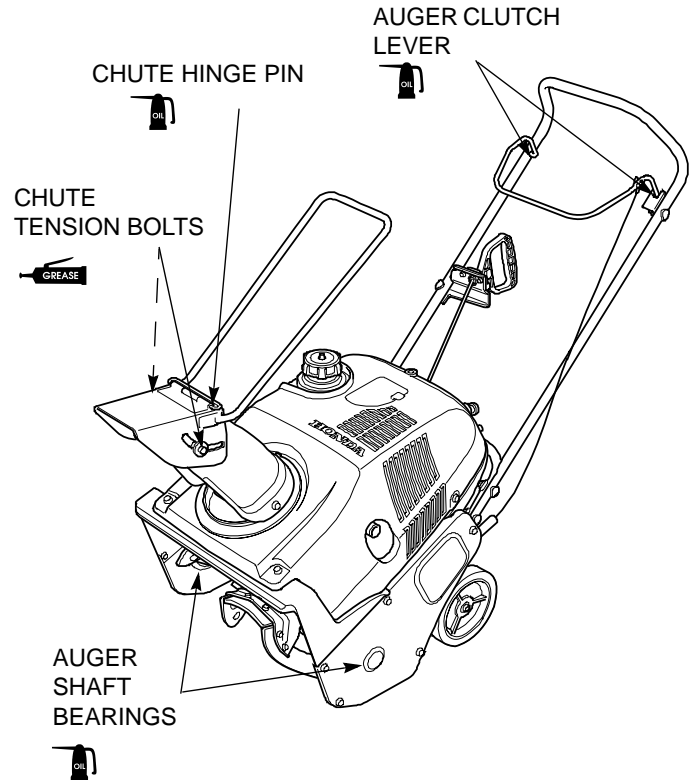

PLACING IN STORAGE

If your snowthrower will be stored with gasoline in the fuel tank and carburetor, it is important to reduce the hazard of gasoline vapor ignition. Select a well-ventilated storage area away from any appliance that operates with a flame, such as a furnace, water heater, or clothes dryer. Also avoid any area with a spark-producing electric motor, or where power tools are operated.

If possible, avoid storage areas with high humidity, because it promotes rust and corrosion.

Unless all fuel has been drained from the fuel tank, leave the fuel valve in the OFF position ([page 6](#)) to reduce the possibility of fuel leakage.

Place the snowthrower on a level surface. Tilting can cause fuel or oil leakage.

With the engine and exhaust system cool, cover the snowthrower to keep out dust. A hot engine and exhaust system can ignite or melt some materials.

Do not use sheet plastic as a dust cover. A nonporous cover will trap moisture around the snowthrower, promoting rust and corrosion.

REMOVAL FROM STORAGE

Check your snowthrower as described in *BEFORE OPERATION* ([page 7](#)).

If the fuel was drained during storage preparation, fill the tank with fresh gasoline. If you keep a container of gasoline for refueling, be sure that it contains only fresh gasoline. Gasoline oxidizes and deteriorates over time, causing hard starting.

If the cylinder was coated with oil during storage preparation, the engine may smoke briefly at startup. This is normal.

TAKING CARE OF UNEXPECTED PROBLEMS

Electric starter does not operate

Possible cause	Correction
No electric power from the outlet.	Try a known good electrical outlet or start the engine by using the recoil starter.
Defective power cord.	Try another power cord or start the engine using the recoil starter.

Starter operates, but the engine will not start

Possible cause	Correction
Fuel valve is OFF.	Turn the fuel valve to ON (page 6).
Stale or old fuel.	Be sure the tank has fresh fuel. Drain the carburetor (page 15).
Spark plug cap is off.	Make sure the cap is connected.
Improper gap or deposits in the spark plug gap.	Verify the spark plug is free of deposits and has the proper gap (page 12).

Engine runs, but snowthrower doesn't operate

Possible cause	Correction
Auger paddles are worn out.	Replace the auger paddles.
Auger clutch lever is not engaged.	Engage the auger clutch lever by pulling it toward the handlebar.
Drive clutch lever free play is excessive.	Adjust the free play (page 13).
Auger not engaging because the drive belt is worn, broken, or not on the pulleys.	See you servicing Honda snowthrower dealer.

Engine has low power

Possible cause	Correction
Fast ground speed puts excessive load on the engine.	Reduce your walking speed.
Wet, deep snow puts an excessive load on the engine.	Reduce the snowthrowing swath.
Discharge chute is restricted.	Clear the discharge chute of obstructions (page 9).
Spark plug cap is not secure.	Make sure the spark plug cap is securely connected.
Improper electrode gap or deposits on the gap.	Verify the spark plug is free of deposits and has the proper gap (page 12).
Choke in the wrong position.	Make sure the choke is in the OPEN position (page 8).
Stale or old fuel.	Be sure the tank has fresh fuel. Drain the carburetor (page 15).

Snow not discharging properly

Possible cause	Correction
Discharge chute is restricted.	Clear the discharge chute of obstructions (page 9).
Foreign object stopping the auger from rotating.	Remove the foreign object.
Auger not engaging because the drive belt is worn, broken, or not on the pulleys.	See servicing Honda snowthrower dealer.
Swath is too wide for wet, deep snow conditions.	Reduce snowblowing swath.
Snowthrower is moving too fast for snow conditions.	Reduce your walking speed.

Engine stalls when the auger clutch lever is engaged

Possible cause	Correction
Discharge chute is restricted.	Clear the discharge chute and auger housing of obstructions (page 9).
Foreign object is stopping the auger from rotating.	
The auger is frozen.	

TECHNICAL INFORMATION

SERIAL NUMBER LOCATIONS

ENGINE SERIAL NUMBER

Use a flashlight to view through the hole for the exhaust pipe. The number starts with "GC..."

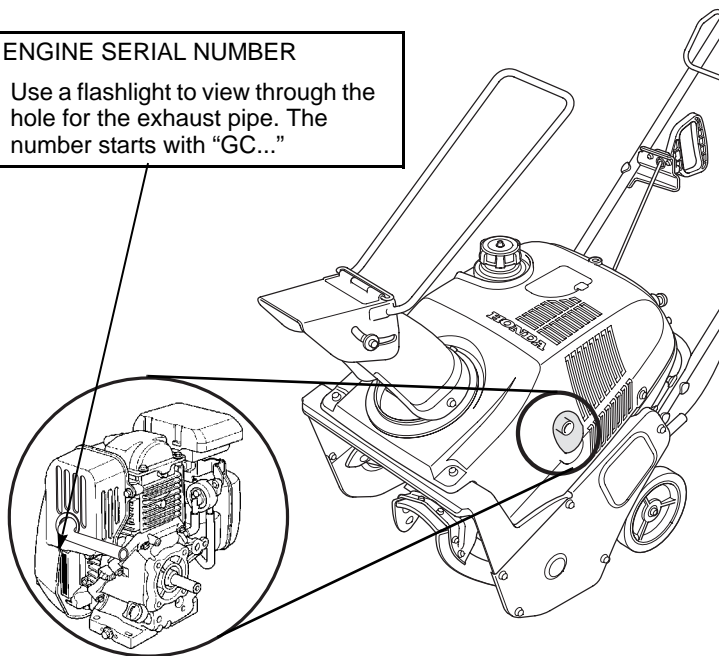

FRAME SERIAL NUMBER

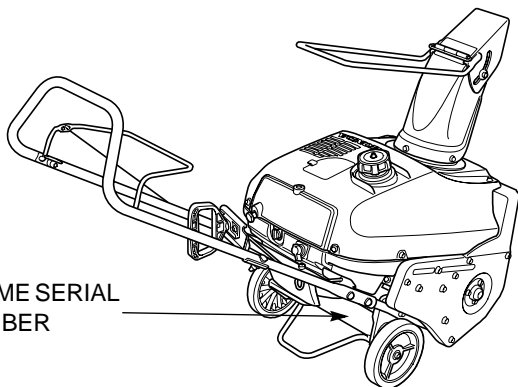

There are two serial numbers, one for the engine and one for the frame. Record the engine and frame serial numbers and date of purchase in the spaces below. You will need these serial numbers when ordering parts and when making technical or warranty inquiries.

Engine serial number: _____

Frame serial number: _____

Date of purchase: _____

CARBURETOR MODIFICATION FOR HIGH ALTITUDE OPERATION

At high altitude, the standard carburetor air-fuel mixture will be too rich. Performance will decrease, and fuel consumption will increase. A very rich mixture will also foul the spark plug and cause hard starting. Operation at an altitude that differs from that at which this engine was certified, for extended periods of time, may increase emissions.

High altitude performance can be improved by specific modifications to the carburetor. If you always operate your snowthrower at altitudes above 5,000 feet (1,500 meters), have your servicing dealer perform this carburetor modification. This engine, when operated at high altitude with the carburetor modifications for high altitude use, will meet each emission standard throughout its useful life.

Even with carburetor modification, engine horsepower will decrease about 3.5% for each 1,000-foot (300-meter) increase in altitude. The effect of altitude on horsepower will be greater than this if no carburetor modification is made.

NOTICE

When the carburetor has been modified for high altitude operation, the air-fuel mixture will be too lean for low altitude use. Operation at altitudes below 5,000 feet (1,500 meters) with a modified carburetor may cause the engine to overheat and result in serious engine damage. For use at low altitudes, have your servicing dealer return the carburetor to original factory specifications.

EMISSION CONTROL SYSTEM

Source of Emissions

The combustion process produces carbon monoxide, oxides of nitrogen, and hydrocarbons. Control of hydrocarbons and oxides of nitrogen is very important because, under certain conditions, they react to form photochemical smog when subjected to sunlight. Carbon monoxide does not react in the same way, but it is toxic.

Honda utilizes appropriate air/fuel ratios and other emissions control systems to reduce the emissions of carbon monoxide, oxides of nitrogen, and hydrocarbons.

The U.S., California Clean Air Act, and Environment Canada

EPA, California, and Canadian regulations require all manufacturers to furnish written instructions describing the operation and maintenance of emissions control systems.

The following instructions and procedures must be followed in order to keep the emissions from your Honda engine within the emissions standards.

Tampering and Altering

NOTICE

Tampering is a violation of Federal and California law.

Tampering with or altering the emissions control system may increase emissions beyond the legal limit. Among those acts that constitute tampering are:

- Removal or alteration of any part of the intake, fuel, or exhaust systems.
- Altering or defeating the speed-adjusting mechanism to cause the engine to operate outside its design parameters.

Problems That May Affect Emissions

If you are aware of any of the following symptoms, have your engine inspected and repaired by your authorized Honda servicing dealer.

- Hard starting or stalling after starting
- Rough idle
- Misfiring or backfiring under load
- Afterburning (backfiring)
- Black exhaust smoke or high fuel consumption

Replacement Parts

The emission control systems on your new Honda engine were designed, built, and certified to conform with EPA, California, and Canadian emission regulations. We recommend the use of Honda Genuine parts whenever you have maintenance done. These original-design replacement parts are manufactured to the same standards as the original parts, so you can be confident of their performance. The use of replacement parts that are not of the original design and quality may impair the effectiveness of your emission control system.

A manufacturer of an aftermarket part assumes the responsibility the part will not adversely affect emission performance. The manufacturer or rebuilder of the part must certify that use of the part will not result in a failure of the engine to comply with emission regulations.

Maintenance

Follow the *MAINTENANCE SCHEDULE* on [page 11](#). Remember that this schedule is based on the assumption that your machine will be used for its designed purpose. Sustained high-load operation will require more frequent service.

AIR INDEX

An Air Index Information hang tag/label is applied to engines certified to an emission durability time period in accordance with the requirements of the California Air Resources Board.

The bar graph is intended to provide you, our customer, the ability to compare the emissions performance of available engines. The lower the Air Index, the less pollution.

The durability description is intended to provide you with information relating to the engine's emission durability period. The descriptive term indicates the useful life period for the engine's emission control system. See your *EMISSION CONTROL SYSTEM WARRANTY* ([page 21](#)) for additional information.

Descriptive Term	Applicable to Emission Durability Period
Moderate	50 hours (0–80 cc inclusive) 125 hours (greater than 80 cc)
Intermediate	125 hours (0–80 cc inclusive) 250 hours (greater than 80 cc)
Extended	300 hours (0–80 cc inclusive) 500 hours (greater than 80 cc) 1000 hours (225 cc and greater)

SPECIFICATIONS

Frame

Model	HS520
Description code	SZBG
Length x Width x Height	49.5 x 20.7 x 40.4 in (1258 x 527 x 1026 mm)
Dry weight	HS520A: 82 lbs (37 kg) HS520AS: 88 lbs (40 kg)
Snow clearance (h x w)	12 x 20 inches (306 x 500 mm)
Max. snowthrowing distance (varies with conditions and snow)	Front: 26 feet (8 m) Left/right: 16 feet (5 m)
Continuous operating time*	1.6 hours
Clearing capacity	55 tons/hour (50 metric tons/hour)
Noise level	84.4 dB(A)

* Operating time will vary depending on the depth and weight of the snow.

Engine Design and Performance

Model	GC160
Displacement	9.8 cubic inches (161 cc)
Bore x stroke	2.5 x 2.0 inches (64 x 50 mm)
Starting method	HS520: recoil (pull start) HS520AS: recoil or AC electric
Ignition system	Transistorized magneto
Oil capacity	0.63 US quart (20.3 fl oz, 0.6 liter)
Fuel tank capacity	0.3 US gallon (1.3 liters)
Spark plug	NGK: BPR5ES or DENSO: W16EPR-U

Maintenance

Fuel	Unleaded gasoline with an octane rating of 86 or higher	See page 11
Engine oil	SAE 5W-30 API SJ or later	See page 12

Tune-up

Spark plug gap	0.028 ~ 0.031 in (0.70 ~ 0.80 mm)
Valve clearance	intake: 0.15 mm exhaust: 0.20 mm
Other specifications	No other adjustments needed

CONSUMER INFORMATION

REPLACEMENT PARTS, OPTIONAL EQUIPMENT, AND SERVICE ITEMS

Contact an authorized Honda servicing dealer to purchase any of these (or other) Honda Genuine items for your snowthrower.

Replacement Parts

Item	Part Number	Notes
Spark plug	98079-55846	NGK (brand) BPR5ES
Scraper blade	76322-V10-020	
Scraper blade nut, 8 mm	90309-428-731	
Scraper blade washer, 8.5 mm	90521-259-000	

Optional Equipment

Item	Part Number	Notes
No-Spill gas can	06176-1450	5 gal
Storage cover	06520-768-000AH	

Service Items

Item	Part Number	Notes
SAE 5W-30 engine oil	08207-5W30	Honda Genuine recommended oil
Fuel stabilizer	08732-0001	For long term storage 8 oz. bottle

DEALER LOCATOR INFORMATION

To find an Authorized Honda Servicing Dealer anywhere in the United States:

Visit www.hondapowerequipment.com and click on *Dealer Locator*

CUSTOMER SERVICE INFORMATION

Honda Power Equipment dealership personnel are trained professionals. They should be able to answer any question you may have. If you encounter a problem that your dealer does not solve to your satisfaction, please discuss it with the dealership's management. The Service Manager or General Manager can help. Almost all problems are solved in this way.

If you are dissatisfied with the decision made by the dealership's management, contact the Honda Power Equipment Customer Relations Office. You can write:

American Honda Motor Co., Inc.
Power Equipment Division
Customer Relations Office
4900 Marconi Drive
Alpharetta, GA 30005-8847

Or telephone: (770) 497-6400 M-F, 8:30 a.m. - 7:00 p.m. ET

When you write or call, please give us this information:

- Model and serial numbers ([page 17](#))
- Name of the dealer who sold the snowthrower to you
- Name and address of the dealer who services your snowthrower
- Date of purchase
- Your name, address, and telephone number
- A detailed description of the problem

Honda Publications

These publications will give you additional information for maintaining and repairing your snowthrower.

Shop Manual - This manual covers complete maintenance and overhaul procedures. It is intended to be used by a skilled technician. Available through your Honda dealer or visit www.hondapowerequipment.com and click on *Product Manuals*.

Parts Catalog - This manual provides complete, illustrated parts lists, and is available through your Honda dealer.

Accessories Catalog - Your authorized Honda power equipment dealer offers a wide selection of accessories to make your snowthrower even more useful. Visit www.hondapowerequipment.com and click on *ACCESSORIES* to see the entire catalog of accessories.

Frequently Asked Questions - The Honda Power Equipment web site provides additional information for users of Honda power equipment. Visit www.hondapowerequipment.com and click on *FAQs*.

DISTRIBUTOR'S LIMITED WARRANTY

Honda Power Equipment

This warranty is limited to the following Honda Power Equipment products when distributed by American Honda Motor Co., Inc., Power Equipment Division, 4900 Marconi Drive, Alpharetta, Georgia 30005-8847. The following warranty applies to products purchased at retail or placed in rental service on or after January 1, 2010.

PRODUCTS COVERED BY THIS WARRANTY	LENGTH OF WARRANTY (from date of original retail purchase)	
	PRIVATE RESIDENTIAL ⁽¹⁾	COMMERCIAL/ RENTAL/INSTITUTIONAL
HS520	24 months	12 months

⁽¹⁾ Private residential: Used in maintaining owner's primary and/or secondary residence. Any other use, including but not limited to informal "for hire" use, is considered commercial/rental/institutional use.

To Qualify for This Warranty:

The product must be purchased in the United States, Puerto Rico, or the U.S. Virgin Islands from American Honda or a dealer authorized by American Honda to sell those products. This warranty applies to the first retail purchaser and each subsequent owner during the applicable warranty time period.

What American Honda Will Repair or Replace Under Warranty:

American Honda will repair or replace, at its option, any part that is proven to be defective in material or workmanship under normal use during the applicable warranty time period. Warranty repairs and replacements will be made without charge for parts or labor. Anything replaced under warranty becomes the property of American Honda Motor Company, Inc. All parts replaced under warranty will be considered as part of the original product, and any warranty on those parts will expire coincident with the original product warranty.

To Obtain Warranty Service:

You must, at your expense, take the Honda Power Equipment product, accessory, replacement part, apparel, or the power equipment on which the accessory or replacement part is installed, and proof of purchase to any Honda Power Equipment dealer in the United States, Puerto Rico, or the U.S. Virgin Islands who is authorized to sell that product, during the dealer's normal business hours. If you are unable to obtain warranty service or are dissatisfied with the warranty service you receive, take the following steps: First, contact the owner of the dealership involved; normally this will resolve the problem. However, if you should require further assistance, write or call the Power Equipment Customer Relations Dept. of American Honda Motor Co., Inc. at the following address:

American Honda Motor Co., Inc.
Power Equipment Customer Relations Dept.
4900 Marconi Drive
Alpharetta, GA 30005-8847 Telephone: (770) 497-6400

Exclusions:

- Any damage or deterioration resulting from the following:
 - Neglect of the periodic maintenance as specified in this manual
 - Improper repair or maintenance
 - Operating methods other than those indicated in this manual
 - The use of non-genuine Honda parts and accessories other than those approved by Honda (other than recommended lubricants and fluids)
 - Exposure of the product to soot and smoke, chemical agents, bird droppings, sea water, sea breeze, salt or other environmental phenomena
 - Collision, fuel contamination or deterioration, neglect, unauthorized alteration, misuse, incorporation or use of unsuitable attachments or parts
 - Natural wear and tear (natural fading of painted or plated surfaces, sheet peeling and other natural deterioration)
- Consumable parts: Honda does not warrant parts deterioration due to natural wear and tear. The parts listed below are not covered by warranty (unless they are needed as a part of another warranted repair):
 - Spark plug, fuel filter, air cleaner element, clutch disc, tire, wheel bearing, recoil starter rope, cable, belt, cutter blade.
 - Lubricant: oil and grease.
- Cleaning, adjustment, and normal periodic maintenance work (carburetor cleaning, engine oil draining, blade sharpening, belt and cable adjustments).
- Any product that has ever been declared a total loss or sold for salvage by a financial institution or insurer.
- Auger and paddle assemblies of snowthrowers, tiller tines of roto-tillers, mower blades and mower deck housings, are specifically not warranted against impact damage, including but not limited to, abrasive damage.

Disclaimer of Consequential Damage and Limitation of Implied Warranties:

American Honda disclaims any responsibility for loss of time or use of the product, transportation, commercial loss, or any other incidental or consequential damage. Any implied warranties are limited to the duration of this written limited warranty. Some states do not allow limitations on how long an implied warranty lasts and/or do not allow the exclusion or limitation of incidental or consequential damages, so the above exclusions and limitations may not apply to you. This warranty gives you specific legal rights, and you may also have other rights which vary from state to state.

Honda Accessories, Replacement Parts, And Apparel

This warranty is limited to Honda Power Equipment parts, accessories, and apparel when distributed by American Honda Motor Co., Inc., 4900 Marconi Drive, Alpharetta, Georgia 30005-8847.

PRODUCTS COVERED BY THIS WARRANTY	LENGTH OF WARRANTY (from date of original retail purchase)	
	PRIVATE RESIDENTIAL	COMMERCIAL/ RENTAL/INSTITUTIONAL
Accessories	12 months	3 months
Replacement parts	6 months	3 months
Apparel	6 months	3 months

To Qualify for This Warranty:

- The accessories, replacement parts, or apparel must be purchased from American Honda, or a dealer, distributor, or distributor's dealer authorized by American Honda to sell those products in the United States, Puerto Rico, and the U.S. Virgin Islands. Parts and Accessories must be purchased for installation on original Honda equipment or engines to be eligible for warranty coverage. Installing parts and accessories on non-Honda products or engines voids this warranty.
- You must be the first retail purchaser. This warranty is not transferable to subsequent owners.

What American Honda Will Repair or Replace Under Warranty:

American Honda will repair or replace, at its option, any Honda Power Equipment accessories, replacement parts, or apparel that are proven to be defective in material or workmanship under normal use during the applicable warranty time period. Anything replaced under warranty becomes the property of American Honda Motor Company, Inc. All parts replaced under warranty will be considered as part of the original product, and any warranty on those parts will expire coincident with the original product warranty.

Accessories and replacement parts installed by a dealer, distributor, or distributor's dealer who is authorized by American Honda to sell them will be repaired or replaced under warranty without charge for parts or labor. If installed by anyone else, accessories and replacement parts will be repaired or replaced under warranty without charge for parts, but any labor charges will be the responsibility of the purchaser. Apparel will be repaired or replaced under warranty without any charge.

To Obtain Warranty Service:

You must, at your expense, take the Honda Power Equipment accessory, replacement part, apparel, or the Honda Power Equipment on which the accessory or replacement part is installed, and proof of purchase to any Honda Power Equipment dealer, distributor, or distributor's dealer in the United States, Puerto Rico, or the U.S. Virgin Islands who is authorized to sell that product, during the dealer's or distributor's normal business hours. If you are unable to obtain warranty service or are dissatisfied with the warranty service you receive, take the following steps: First, contact the owner of the dealership or distributorship involved; normally this will resolve the problem. However, if you should require further assistance, write or call the Power Equipment Customer Relations Department of American Honda Motor Co., Inc. Refer to adjacent column for contact information.

Exclusions:

This warranty does not extend to accessories, parts, or apparel affected or damaged by collision, normal wear, use in an application for which the product was not designed or any other misuse, neglect, incorporation or use of unsuitable attachments or parts, unauthorized alteration, improper installation, or any causes other than defects in material or workmanship of the product. Installing Parts and Accessories on non-Honda products or engines voids this warranty.

Disclaimer of Consequential Damage and Limitation of Implied Warranties:

American Honda disclaims any responsibility for loss of time or use of the product, or the power equipment on which the product is installed, transportation, commercial loss, or any other incidental or consequential damage. Any implied warranties are limited to the duration of this written warranty. Some states do not allow limitations on how long an implied warranty lasts and/or do not allow the exclusion or limitation of incidental or consequential damages, so the above exclusions and limitations may not apply to you. This warranty gives you specific legal rights, and you may also have other rights which vary from state to state.

EMISSION CONTROL SYSTEM WARRANTY

Your new Honda Power Equipment engine complies with the U.S. EPA, Environment Canada, and State of California emission regulations (models certified for sale in California only). American Honda Motor Co., Inc. provides the emission warranty coverage for engines in the United States and its territories. Honda Canada Inc. provides the emission warranty for engines in the 13 provinces and territories of Canada. In the remainder of this Emission Control System Warranty, American Honda Motor Company Inc. and Honda Canada Inc. will be referred to as Honda.

YOUR WARRANTY RIGHTS AND OBLIGATIONS:

CALIFORNIA

The California Air Resources Board and Honda are pleased to explain the emission control system warranty on your Honda Power Equipment engine. In California, new spark-ignited small off-road equipment engines must be designed, built, and equipped to meet the State's stringent anti-smog standards.

OTHER STATES, U.S. TERRITORIES, AND CANADA

In other areas of the United States and in Canada, your engine must be designed, built, and equipped to meet the U.S. EPA and Environment Canada emission standards for spark-ignited engines at or below 19 kilowatts. Specific Honda products that do not meet the California emissions regulations can be identified by a "Not for sale in California" decal.

ALL OF THE UNITED STATES AND CANADA

Honda must warrant the emission control system on your power equipment engine for the period of time listed below, provided there has been no abuse, neglect, or improper maintenance of your power equipment engine. Where a warrantable condition exists, Honda will repair your power equipment engine at no cost to you including diagnosis, parts, and labor.

Your emission control system may include such parts as the carburetor or fuel injection system, the ignition system, and catalytic converter. Also included may be hoses, connectors, and other emission-related assemblies. (See adjacent table for additional covered parts).

OWNER'S WARRANTY RESPONSIBILITY:

As the power equipment engine owner, you are responsible for the performance of the required maintenance listed in your owner's manual. Honda recommends that you retain all receipts covering maintenance on your power equipment engine, but Honda cannot deny warranty coverage solely for the lack of receipts or for your failure to ensure the performance of all scheduled maintenance.

As the power equipment engine owner, you should however be aware Honda may deny you warranty coverage if your power equipment engine or a part has failed due to abuse, neglect, improper maintenance, or unapproved modifications.

You are responsible for presenting your power equipment engine to a Honda Power Equipment dealer as soon as a problem exists. The warranty repairs should be completed in a reasonable amount of time, not to exceed 30 days. If you have any questions regarding your emissions warranty rights and responsibilities, you should contact the Honda Office in your region:

American Honda Motor Co., Inc.
Power Equipment Customer
Relations
4900 Marconi Drive
Alpharetta, Georgia 30005-8847
Telephone: (888) 888-3139
Email: powerequipmentemissions
@ahm.honda.com

or

Honda Canada Inc.
Power Equipment Customer
Relations
Please visit: www.honda.ca
for contact information.
Telephone: (888) 946-6329

WARRANTY COVERAGE:

Honda power equipment engines sold in the United States and Canada are covered by this warranty for a period of two years from the date of delivery to the original retail purchaser or the length of the Honda Distributor's Limited Warranty, whichever is longer. This warranty is transferable to each subsequent purchaser for the duration of the warranty period.

If any emission-related part on your engine is defective, the part will be repaired or replaced by Honda without charge for diagnosis, parts, or labor. All defective parts replaced under this warranty become the property of Honda. A list of warranted parts is in the adjacent column. Normal maintenance items, such as spark plugs and filters, that are on the warranted parts list are warranted up to their required replacement interval only.

Honda will also replace other engine components damaged by a failure of any warranted part during the warranty period.

Only Honda approved replacement parts may be used in the performance of any warranty repairs and must be provided without charge to the owner. The use of replacement parts not equivalent to the original parts may impair the effectiveness of your engine emission control system. If such a replacement part is used in the repair or maintenance of your engine, and an authorized Honda dealer determines it is defective or causes a failure of a warranted part, your claim for repair of your engine may be denied. If the part in question is not related to the reason your engine requires repair, your claim will not be denied.

TO OBTAIN WARRANTY SERVICE:

You must, at your own expense, take your Honda Power Equipment engine or the product on which it is installed, along with your sales registration card or other proof of original purchase date, to any Honda Power Equipment dealer who is authorized by Honda to sell and service that Honda product during his normal business hours. Claims for repair or adjustment found to be caused solely by defects in material or workmanship will not be denied because the engine was not properly maintained and used.

If you are unable to obtain emission warranty service or are dissatisfied with the warranty service you received, contact the owner of the dealership involved. Normally this should resolve your problem. However, if you require further assistance, contact the Honda office in your region. Refer to adjacent column for contact information.

EXCLUSIONS:

Failures other than those resulting from defects in material or workmanship are not covered by this warranty. This warranty does not extend to emission control systems or parts that are affected or damaged by owner abuse, neglect, improper maintenance, misuse, misfueling, improper storage, collision, the incorporation of, or use of, unsuitable attachments, or the unauthorized alteration of any part.

This warranty does not cover replacement of expendable maintenance items made in connection with required maintenance service after the item's first scheduled replacement as listed in the maintenance section of the product Owner's Manual, such as: spark plugs and filters.

DISCLAIMER OF CONSEQUENTIAL DAMAGE AND LIMITATION OF IMPLIED WARRANTIES:

American Honda Motor Co., Inc. and Honda Canada disclaim any responsibility for incidental or consequential damages such as loss of time or the use of the power equipment, or any commercial loss due to the failure of the equipment; and any implied warranties are limited to the duration of this written warranty. This warranty is applicable only where the California, U.S. EPA or Environment Canada emission control system warranty regulation is in effect

EMISSION CONTROL SYSTEM WARRANTY PARTS:

SYSTEMS COVERED BY THIS WARRANTY:	PARTS DESCRIPTION:
Fuel Metering	Carburetor assembly, (includes starting enrichment system), Engine temperature sensor, Engine control module, Fuel regulator, Intake manifold
Evaporative	Fuel tank, Fuel cap, Fuel hoses, Vapor hoses, Carbon canister, Canister mounting brackets, Fuel strainer, Fuel cock, Fuel pump, Fuel hose joint, Canister purge hose joint
Exhaust	Catalyst, Exhaust manifold
Air Induction	Air filter housing, Air filter element*
Ignition	Flywheel magneto, Ignition pulse generator, Crankshaft position sensor, Power coil, Ignition coil assembly, Ignition control module, Spark plug cap, Spark plug*
Crankcase Emission Control	Crankcase breather tube, Oil filler cap
Miscellaneous Parts	Tubing, fittings, seals, gaskets, and clamps associated with these listed systems.

Note: This list applies to parts supplied by Honda and does not cover parts supplied by the equipment manufacturer. Please see the original equipment manufacturer's emissions warranty for non-Honda parts.

* Covered up to the first required replacement only. See the *MAINTENANCE SCHEDULE* on [page 11](#).

NOTES

PRODUCT REGISTRATION

PLEASE COMPLETE and MAIL or REGISTER ONLINE

www.HondaPowerEquipment.com

Honda HRX Mowers

Look on the left rear section of the mower deck, in front of the discharge guard door spring.

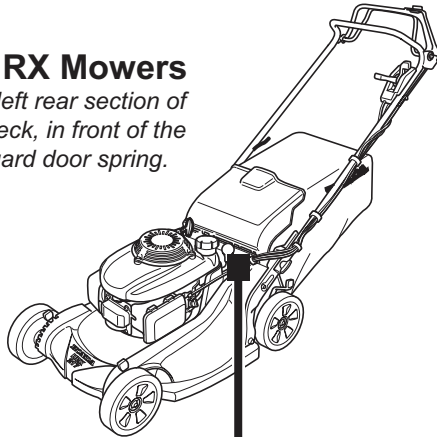

Honda HR Mowers

Look on the center rear section of the mower deck (HRS), and in front of the discharge guard (HRR).

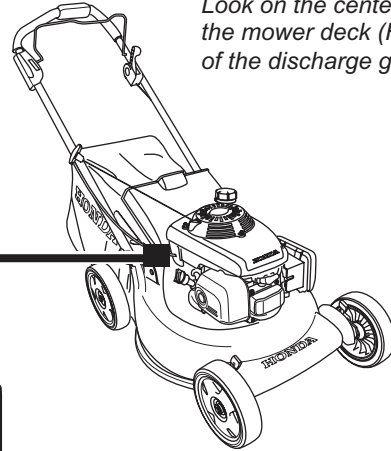

Honda Mini-Tiller

Look on the right side of the tine shield.

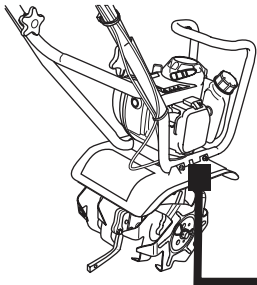

MODEL: XXXX XXXX
SERIAL NO: XXXX-XXXXXXX

Honda Hand-Held Products

Look on the shaft between the two grips.

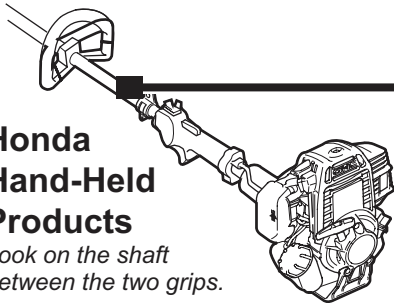

Print the serial number here.

Honda Snowthrowers

Look between the wheels on the lower frame.

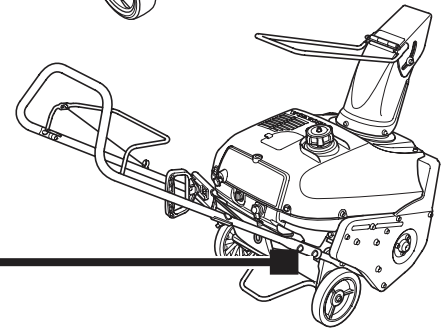

Dear Honda Customer,
Thank you for choosing Honda.

To ensure you receive current product information and service updates, please take a moment to register your product.

You may complete and mail this postage-paid registration card or register online at www.HondaPowerEquipment.com

Failure to register this product does not diminish the purchaser's warranty rights.

Serial number

* Dealer Store number

* Dealer Store ZIP code

*If available

Owner's Last Name

First Name

Company Name (commercial/rental users)

Telephone

Address

City

State

ZIP Code

E-mail address

Date of Purchase

Application (check one)

Commercial
(professional use)

Non-commercial
(private, homeowner use)

Rental
(for-hire use)

MONTH

DAY

YEAR

1. Go www.hondapowerequipment.com to register your unit.

2. Click on **Product Registration**.

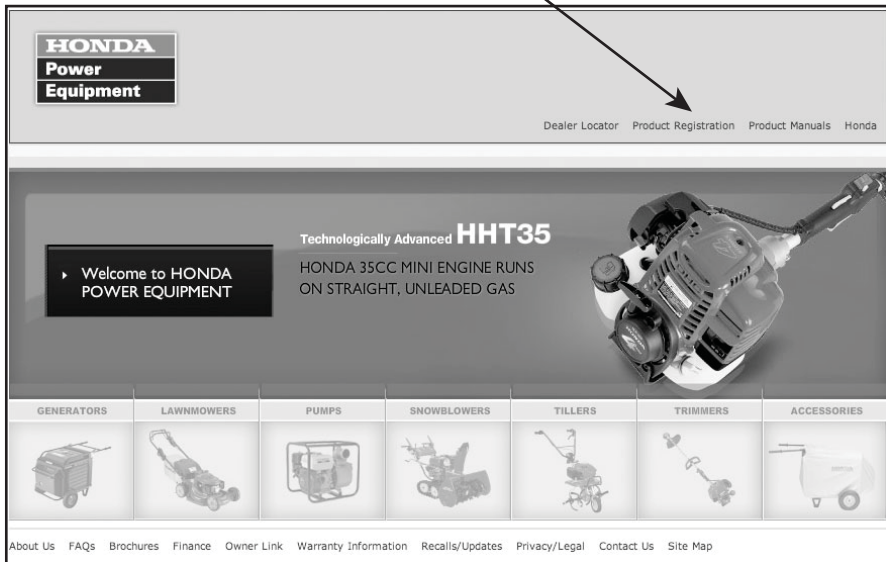

HONDA Power Equipment Close Window

Product Registration

Congratulations on the purchase of your new Honda Product! Thank you for registering online.

Please enter your registration information below.

Your information will remain confidential. It will not be released to any other company or organization.

If you need to change your name, address, phone number or ownership information, please click [here](#).

♦ = required field

Prefix First Name M.I. Last Name Suffix

♦ Address Line 1:

Address Line 2:

♦ City: ♦ State: ♦ Zip Code:

Phone (10 digits no spaces):

♦ Product Serial Number: - [Where can I find my serial number?](#)

♦ Date of Purchase (mm/dd/yyyy)
 / /
Product purchase date must be no earlier than year 2000.

♦ Product Use:

♦ Location Purchased

♦ E-mail Address

♦ Confirm E-mail Address

[Honda.com](#) | [Privacy Policy](#) | [Legal Terms & Conditions](#) | [Visit Honda Powerequipment.com](#)
© 2009 American Honda Motor Co., Inc.

3. Complete the required information and click **Submit**.

It's that simple! You'll receive e-mail confirmation of your registration.

Product Registration



NO POSTAGE
NECESSARY
IF MAILED
IN THE
UNITED STATES

BUSINESS REPLY MAIL
FIRST-CLASS MAIL PERMIT NO. 117 ALPHARETTA GA

POSTAGE WILL BE PAID BY ADDRESSEE

Power Equipment Division
American Honda Motor Co., Inc.
4900 Marconi Dr
Alpharetta, GA 30005-9956

