

# INTRODUCTION

Congratulations on your selection of a Honda diaphragm pump! We are certain you will be pleased with your purchase of one of the finest pumps on the market.

We want to help you get the best results from your new pump and to operate it safely. This manual contains the information on how to do that; please read it carefully.

We suggest you read the *DISTRIBUTOR'S LIMITED WARRANTY* (page 22) and *EMISSION CONTROL SYSTEM WARRANTY* (page 23) to fully understand coverage and your responsibilities of ownership.

When your pump needs scheduled maintenance, keep in mind that an authorized Honda servicing dealer is specially trained in servicing Honda pumps and is supported by the parts and service divisions of American Honda. Your Honda dealer is dedicated to your satisfaction and will be pleased to answer your questions and concerns.

Keep this owner's manual handy, so you can refer to it at any time. This owner's manual is considered a permanent part of the pump and should remain with the pump if resold.

The information and specifications included in this publication were in effect at the time of approval for printing. American Honda Motor Co., Inc. reserves the right, however, to discontinue or change specifications or design at any time without notice and without incurring any obligation whatever. No part of this publication may be reproduced without written permission.

## SAFETY MESSAGES

Your safety and the safety of others are very important. We have provided important safety messages in this manual and on the pump. This information alerts you to potential hazards that could hurt you or others. Please read these messages carefully.

Of course, it is not practical or possible to warn you about all the hazards associated with operating or maintaining a diaphragm pump. You must use your own good judgment.

You will find important safety information in a variety of forms:

- **Safety Labels** – on the pump.
- **Instructions** – how to use this pump correctly and safely.
- **Safety Messages** – preceded by a safety alert ⚠ symbol and one of three signal words: DANGER, WARNING, or CAUTION. These signal words mean:

**⚠ DANGER**

You WILL be KILLED or SERIOUSLY HURT if you don't follow instructions.

**⚠ WARNING**

You CAN be KILLED or SERIOUSLY HURT if you don't follow instructions.

**⚠ CAUTION**

You CAN be HURT if you don't follow instructions.

Each message tells you what the hazard is, what can happen, and what you can do to avoid or reduce injury.

- **Damage Prevention Messages** – You will also see other important messages that are preceded by the word NOTICE. This word means:

**NOTICE**

Your pump, other property, or the environment can be damaged if you don't follow instructions.

# HONDA

## OWNER'S MANUAL WDP30X



### WARNING:



The engine exhaust from this product contains chemicals known to the State of California to cause cancer, birth defects, or other reproductive harm.

## CONTENTS

PUMP SAFETY .....	2	TAKING CARE OF UNEXPECTED PROBLEMS .....	17
IMPORTANT SAFETY INFORMATION .....	2	TECHNICAL INFORMATION .....	17
SAFETY LABEL LOCATIONS .....	2	SERIAL NUMBER LOCATIONS .....	17
SETTING UP YOUR NEW PUMP .....	2	CARBURETOR MODIFICATION FOR HIGH ALTITUDE OPERATION .....	17
CONTROL LOCATIONS .....	3	EMISSION CONTROL SYSTEM .....	18
BEFORE OPERATION .....	3	AIR INDEX .....	18
IS YOUR PUMP READY TO GO? .....	3	SPECIFICATIONS .....	18
OPERATION .....	4	AVOIDING FUEL-RELATED PROBLEMS .....	20
SAFE OPERATING PRECAUTIONS .....	4	CONSUMER INFORMATION .....	21
PUMP PREPARATION .....	5	REPLACEMENT PARTS, OPTIONAL EQUIPMENT, AND SERVICE ITEMS .....	21
STARTING THE ENGINE .....	6	DEALER LOCATOR INFORMATION .....	21
STOPPING THE ENGINE .....	6	CUSTOMER SERVICE INFORMATION .....	21
SERVICING YOUR PUMP .....	7	DISTRIBUTOR'S LIMITED WARRANTY .....	22
MAINTENANCE SAFETY .....	7	EMISSION CONTROL SYSTEM WARRANTY .....	23
MAINTENANCE SCHEDULE .....	7		
ENGINE MAINTENANCE .....	8		
REFUELING .....	11		
PUMP MAINTENANCE .....	12		
TRANSPORTING .....	15		
BEFORE LOADING .....	15		
LOADING AND UNLOADING .....	15		
STORAGE .....	15		
STORAGE PREPARATION .....	15		
PLACING IN STORAGE .....	16		
REMOVAL FROM STORAGE .....	16		

# PUMP SAFETY

This chapter explains what you need to know to operate your diaphragm pump safely.

## IMPORTANT SAFETY INFORMATION

The Honda WDP30X pump is not designed to pump drinking water. Pump only non-potable water, muddy water, and water containing solids. Other uses can result in injury to the operator or damage to the pump and other property.

Most injuries or property damage can be prevented if you follow all instructions in this manual and on the pump. The most common hazards are discussed below, along with the best way to protect yourself and others.

### Operator Responsibility

It is the operator's responsibility to provide the necessary safeguards to protect people and property. Know how to stop the pump quickly in case of emergency. Understand the use of all controls and connections. For your safety and the safety of others, keep the connecting rod cover in place when the engine is running.

Be sure that anyone who operates the pump receives proper instruction. Do not let children operate the pump. Keep children, pets, and bystanders away from the area of operation.

### Pump Operation

Do not pump drinking water. This pump is designed to only pump non-potable water, muddy water, and water containing solids. Pumping flammable liquids, such as gasoline or fuel oils, can result in a fire or explosion, causing serious injury. Pumping sea water, beverages, acids, chemical solutions, or any other liquid that promotes corrosion can damage the pump.

Operate the pump on a level surface. If the engine is tilted, fuel may spill.

### Refuel With Care

Gasoline is extremely flammable, and gasoline vapor can explode. Refuel outdoors, in a well-ventilated area, with the engine stopped and the pump on a level surface. Do not overfill the fuel tank. Never smoke near gasoline, and keep other flames and sparks away. Always store gasoline in an approved container. Make sure that any spilled fuel has been wiped up before starting the engine.

### Hot Exhaust

The muffler becomes very hot during operation and remains hot for a while after stopping the engine. Be careful not to touch the muffler while it is hot. Let the engine cool before transporting the pump or storing it indoors.

To prevent fire hazards, keep the pump at least 3 feet (1 meter) away from building walls and other equipment during operation. Do not place flammable objects close to the engine.

### Carbon Monoxide Hazards

Exhaust gas contains poisonous carbon monoxide. Avoid inhalation of exhaust gas. Never run the engine in a closed garage or confined area.

## SAFETY LABEL LOCATIONS

The label shown here contains important safety information. Please read it carefully. This label is considered a permanent part of your pump. So if the label comes off or becomes hard to read, contact your authorized Honda pump dealer for a replacement.

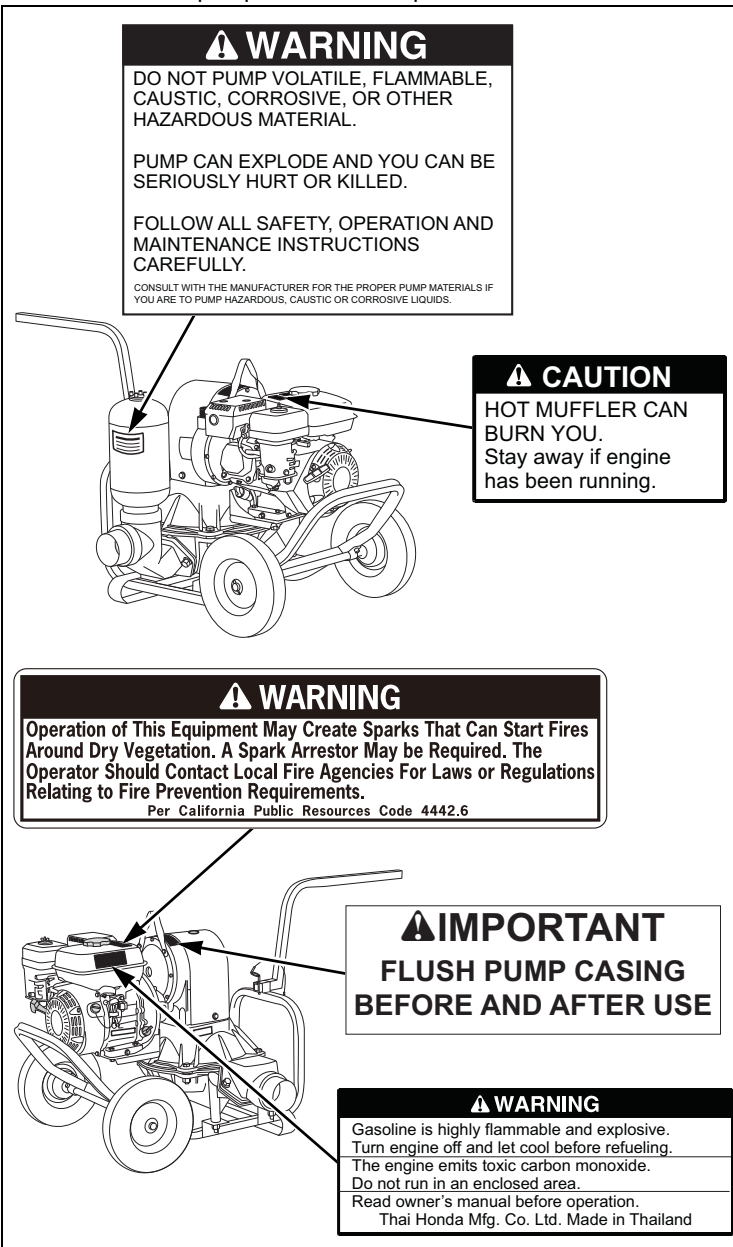

**⚠ WARNING**  
DO NOT PUMP VOLATILE, FLAMMABLE, CAUSTIC, CORROSIVE, OR OTHER HAZARDOUS MATERIAL.  
PUMP CAN EXPLODE AND YOU CAN BE SERIOUSLY HURT OR KILLED.  
FOLLOW ALL SAFETY, OPERATION AND MAINTENANCE INSTRUCTIONS CAREFULLY.  
CONSULT WITH THE MANUFACTURER FOR THE PROPER PUMP MATERIALS IF YOU ARE TO PUMP HAZARDOUS, CAUSTIC OR CORROSIVE LIQUIDS.

**⚠ CAUTION**  
HOT MUFFLER CAN BURN YOU.  
Stay away if engine has been running.

**⚠ WARNING**  
Operation of This Equipment May Create Sparks That Can Start Fires Around Dry Vegetation. A Spark Arrestor May be Required. The Operator Should Contact Local Fire Agencies For Laws or Regulations Relating to Fire Prevention Requirements.  
Per California Public Resources Code 4442.6

**⚠ IMPORTANT**  
FLUSH PUMP CASING BEFORE AND AFTER USE

**⚠ WARNING**  
Gasoline is highly flammable and explosive. Turn engine off and let cool before refueling.  
The engine emits toxic carbon monoxide. Do not run in an enclosed area.  
Read owner's manual before operation.  
Thai Honda Mfg. Co. Ltd. Made in Thailand

## SETTING UP YOUR NEW PUMP

### Unpacking

The handle is installed over the pump for shipment only. Remove the handle release pin and reinstall the handlebar facing outward for ease of handling. Secure with the handle release pin ([page 3](#)).

The engine is shipped **WITHOUT OIL** in the engine. Refer to [page 8](#) for oil recommendations.

### Please Register Your Diaphragm Pump

If your dealer did not collect registration information from you, please take a few minutes and register your purchase with Honda. This allows us to contact you with any important updates regarding your pump. Please note registration is not required to obtain warranty service.

You can register by going online to [PowerEquipment.Honda.com](http://PowerEquipment.Honda.com) and click on Product Registration.

# CONTROL LOCATIONS

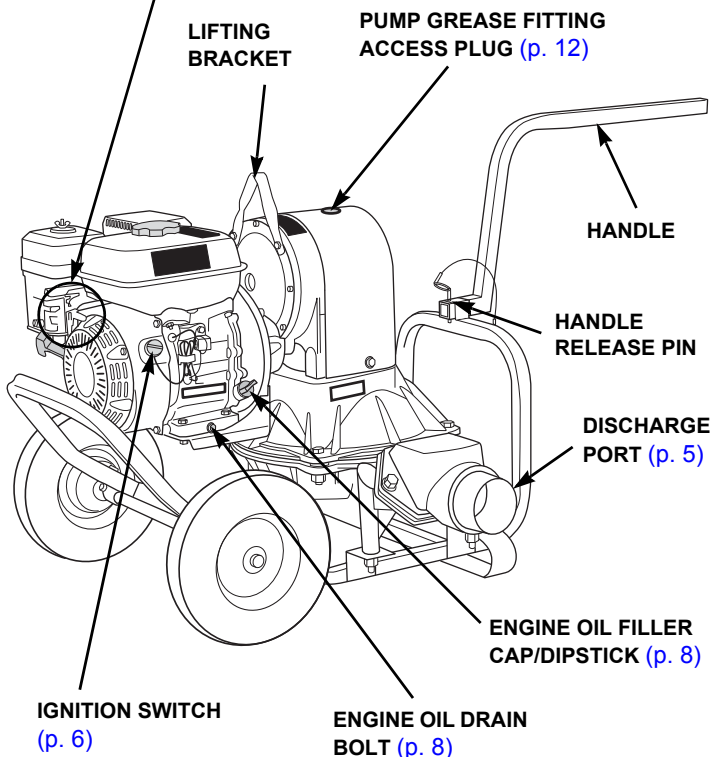
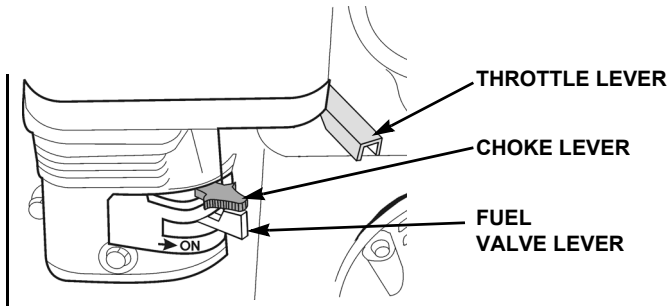
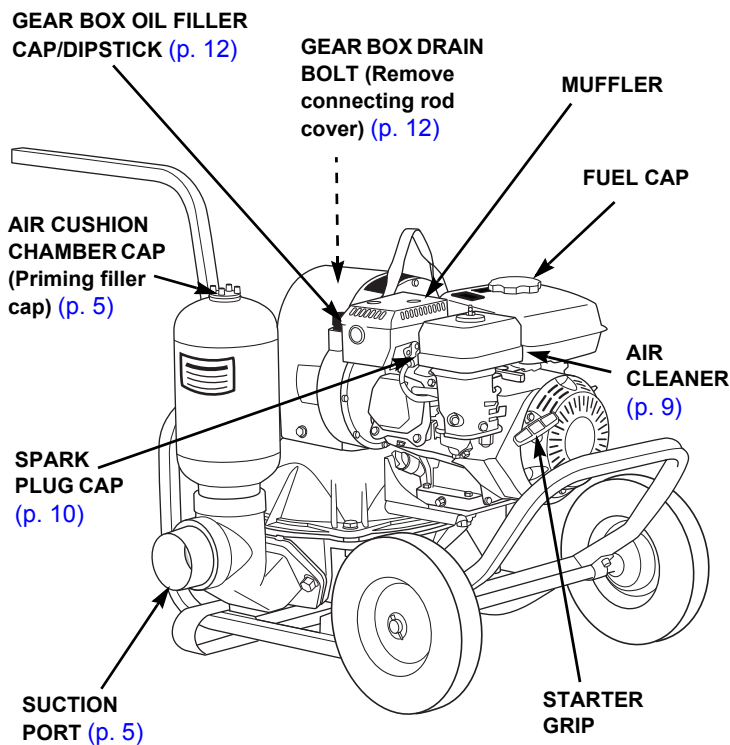

# BEFORE OPERATION

Your safety is your responsibility. A little time spent in preparation will significantly reduce your risk of injury.

Read and understand this manual. Know what the controls do and how to operate them.

Familiarize yourself with the pump and its operation before you begin using it. Know how to quickly shut off the engine in case of an emergency.

Be sure of what you are pumping. This pump is designed to pump only non-potable water, muddy water, and water containing solids.

## IS YOUR PUMP READY TO GO?

For your safety, and to maximize the service life of your equipment, it is very important to take a few moments before you operate the pump to check its condition. Be sure to take care of any problem you find, or have your servicing dealer correct it, before you operate the pump.

## ⚠ WARNING

Improperly maintaining this pump, or failing to correct a problem before operation, could cause a malfunction in which you could be seriously injured.

Always perform a pre-operation inspection before each operation, and correct any problem.

Before beginning your pre-operation checks, be sure the pump is on a level surface and the ignition switch is in the OFF position.

### Check the General Condition of the Pump

- Look around and underneath the pump for signs of oil or gasoline leaks.
- Remove any dirt or debris, especially around the engine, muffler, and recoil starter.
- Look for signs of damage.
- Check that all nuts, bolts, screws, hose connectors, and clamps are tightened.
- Keep the connecting rod cover in place while operating the pump.

### Check the Suction and Discharge Hoses

- Check the general condition of the hoses. Be sure the hoses are in serviceable condition before connecting them to the pump. Remember that the suction hose must be of reinforced construction to prevent hose collapse.
- Check that the sealing washer in the suction hose connector is in good condition (page 12).
- Check that the strainer is in good condition and is installed on the suction hose (page 12).

### Check the Engine

- Check the oil level (page 8). To avoid the inconvenience of an unexpected shutdown by the Oil Alert® system, always check the engine oil level before startup.
- Check the air cleaner (page 9).
- Check the fuel level (page 11). Starting with a full tank will help to eliminate or reduce operating interruptions for refueling.

# OPERATION

## SAFE OPERATING PRECAUTIONS

Before operating the pump for the first time, please review **IMPORTANT SAFETY INFORMATION** (page 2) and **BEFORE OPERATION** (page 3).

For your safety, avoid starting or operating the engine in an enclosed area, such as a garage. Your engine's exhaust contains poisonous carbon monoxide gas, which can collect rapidly in an enclosed area and cause illness or death.

Do not pump drinking water. Pump only non-potable water, muddy water, and water containing solids. Pumping flammable liquids, such as gasoline or fuel oils, can result in a fire or explosion, causing serious injury. Pumping sea water, beverages, acids, chemical solutions, or any other liquid that promotes corrosion can damage the pump.

Due to the pump diaphragm reciprocating motion, pump assembly and hoses will move up and down and side-to-side during pumping. This may cause the pump to walk or move around while pumping. Depending on the surface conditions, pump hose length, and other factors, it may be necessary to anchor the pump to limit pump movement. During operation, observe pump movement and anchor the pump frame and wheels as necessary.

- Attach anchored tie-down straps to the pump frame.
- Place blocks in front and behind the wheels.
- Try to locate the pump on a level surface.

While pumping, the suction hose may move out of the pumping source, and the discharge hose may move away from the pumping destination. It may also be necessary to anchor hose ends to prevent hose movement.

If there is no one to monitor the pump during operation, it is advisable to anchor the pump to prevent unexpected movement.

Pump total dynamic discharge head is limited to a maximum of 50 feet. Total dynamic discharge head includes static discharge head (discharge vertical height) and head loss due to friction. Head loss makes it impractical for the static discharge head to exceed 25 feet. Pumping to a static discharge head greater than 25 feet can damage the pump. See the *Pump Performance Curve* on page 19.

This diaphragm pump should never be run with the discharge output shut off or restricted.

### NOTICE

*Pump case failure may result if the discharge output is shut off or restricted. To avoid pump damage, do not restrict, shut off, or momentarily stop the fluid flow from the discharge hose.*

A rigid pipe should never be used with a diaphragm pump. Flexible hoses must be attached to the pump. The suction hose must be non-collapsible. Never use hoses that are smaller than the suction or discharge fittings.

This pump requires a 3 inch inside diameter or larger hose. Using rigid pipes or hoses that are too small will cause severe damage to the diaphragm pump.

### NOTICE

*Due to pump movement during operation, connecting a rigid pipe to the pump will cause pump damage. Always use flexible suction and discharge hoses to prevent pump damage.*

When water being pumped contains solids, the solids may get lodged under the clappet valves, which will prevent the clappet valves from closing completely. To maintain maximum pump performance, the discharge hose should angle upward as it exits the pump.

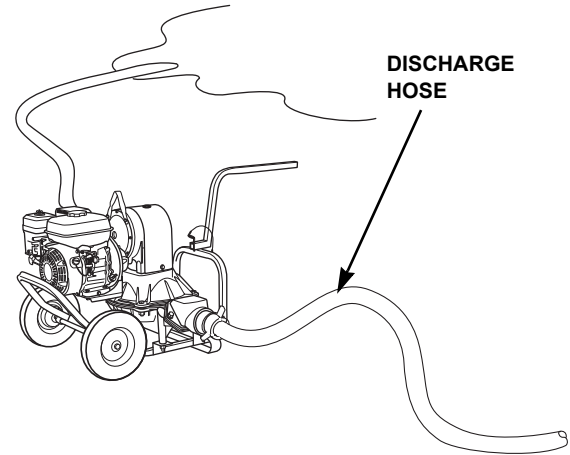

If the discharge hose must run across a roadway, the hose should cross the roadway perpendicular to traffic flow. Also, heavy boards should be placed next to the hose so the motor vehicle weight does not shut off the discharge as vehicles cross over the hose.

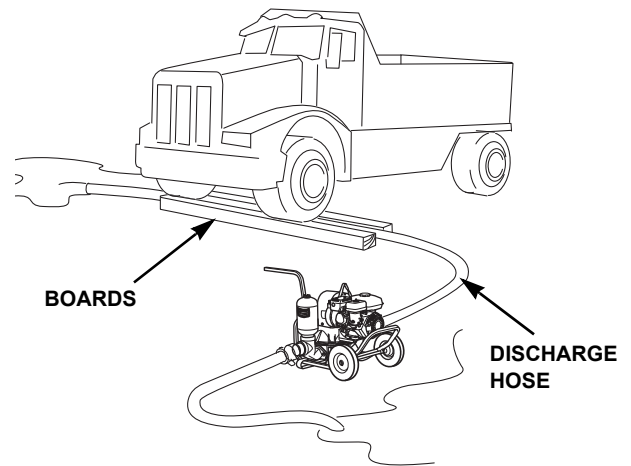

Driving over a discharge hose while the pump is running, or even possibly when the pump is stopped, will most likely cause pump case failure.

### NOTICE

*Collapsing the discharge hose will cause pump case and/or diaphragm damage. To prevent pump damage, take the necessary precautions to prevent the discharge hose from getting compressed or collapsed.*

During freezing weather, always drain the pump case after use. If water is left in the pump case during freezing weather, the pump case will break.

## PUMP PREPARATION

Optional hose kits, designed specifically for this pump, are available from your Honda dealer. See [page 21](#).

### Suction Hose Connection

If using a commercially available hose, ensure it is the same size or larger than the suction port diameter (3 inches). To prevent the hose from collapsing, use a hose that is reinforced with a non-collapsible wall or braided wire construction.

Keep the pump as close as possible to the pumping liquid. Avoid hose bends and sharp turns. Pump performance is best when the pump is not far above the liquid level and the hose is kept straight.

Self-priming time is also proportional to the suction hose length. Using a longer suction hose will increase the self-priming time.

Tighten the hose connector to the suction hose with a hose clamp to prevent air leakage and loss of suction. Verify that the connector sealing washer is installed and in good condition. A loosely connected suction hose will reduce pump performance and self-priming ability.

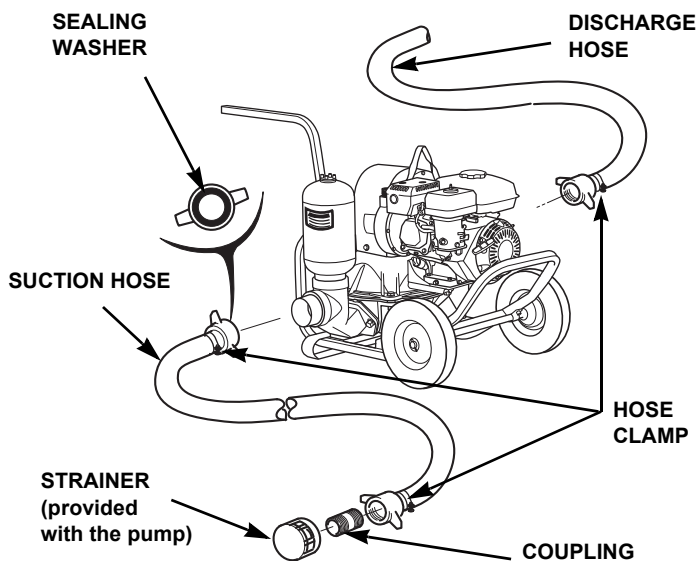

The strainer provided with the pump should be attached to the end of the suction hose as shown.

Always install the strainer on the end of the suction hose before pumping. The strainer will prevent debris from entering the pump that can cause clogging, diaphragm and/or other pump damage.

### Discharge Hose Connection

If using a commercially available hose, a short, large diameter hose will provide lower fluid friction and improve pump output. A long or small diameter hose will increase fluid friction and reduce pump output. Never use a hose size smaller than the discharge port diameter (3 inches).

#### NOTICE

*If a discharge hose is used that has a smaller inside diameter than the port size, the pump case may be damaged. To avoid pump damage, always use the correct size hose.*

Tighten the hose clamp to prevent the hose from disconnecting under high pressure.

## Pump Priming

Pump priming is not required if the vertical distance from water to the pump (suction head) is less than 16 feet. The suction head can be increased to 24 feet if the pump is primed.

To prime the pump, remove the air cushion chamber cap. Grasp the suction hose next to the suction fitting and lift the hose about 1 foot off the ground. Lifting the suction hose will help to ensure the water goes into the pump housing and not out the suction hose.

Pour about 1 gallon of water into the pump case through the air cushion chamber. Lay the hose back on the ground, and reinstall the air cushion chamber cap.

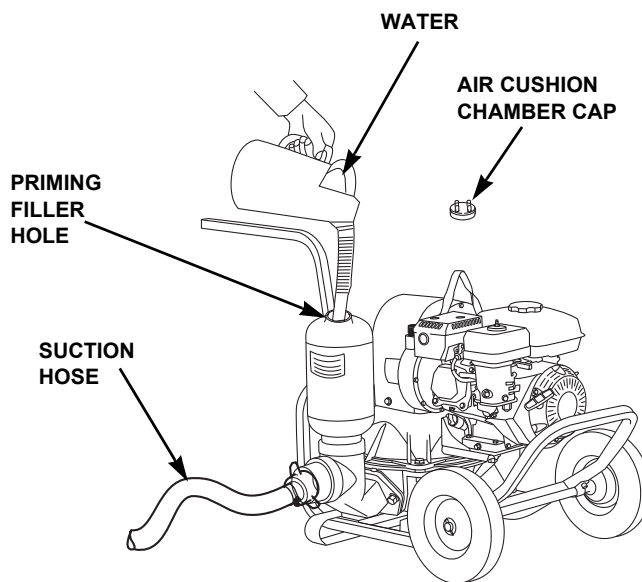

## FREQUENCY OF USE

If your equipment will be used on an infrequent or intermittent basis, (more than 4 weeks before next use), please refer to the *Fuel* section of the *STORAGE* chapter ([page 15](#)) for additional information regarding fuel deterioration.

## STARTING THE ENGINE

1. Turn the fuel valve to the ON position.

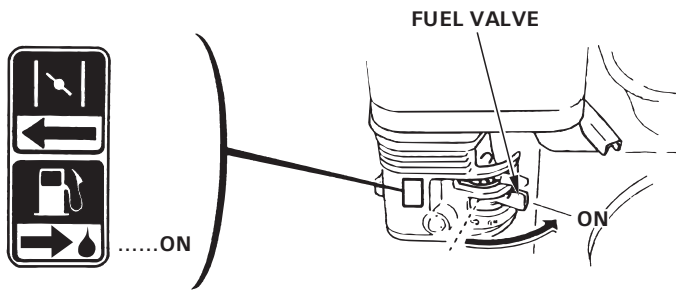

2. Move the choke lever to the CLOSED position.

Do not use the choke if the engine is warm or the ambient temperature is high.

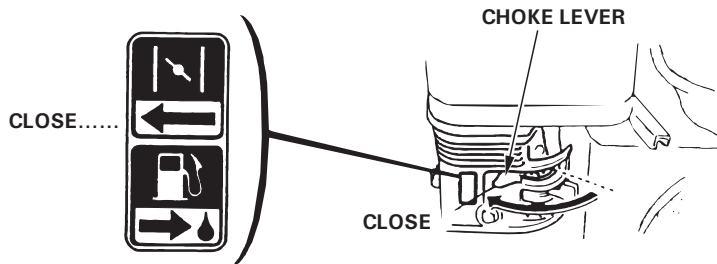

3. Turn the ignition switch to the ON position.

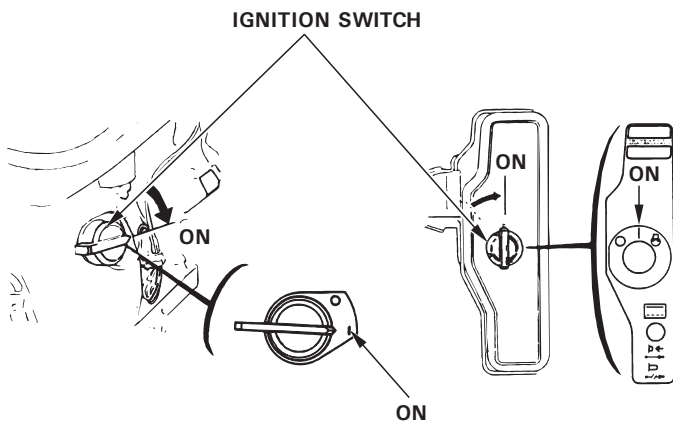

4. Move the throttle control lever slightly to the left.

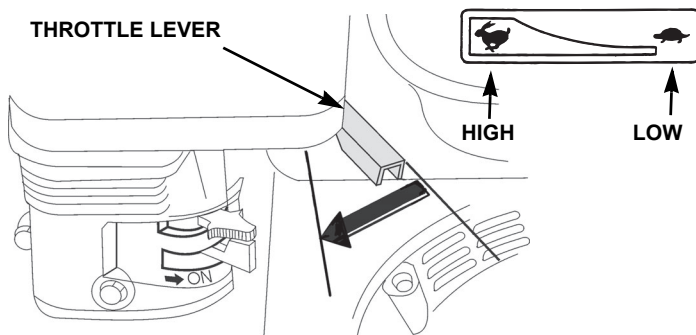

5. Pull the starter grip lightly until resistance is felt, then pull it briskly.

### NOTICE

Return the starter grip slowly back to the engine to prevent damage to the starter.

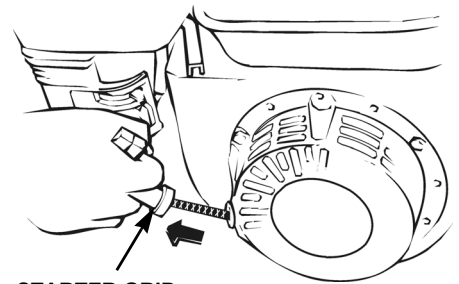

6. As the engine warms up, gradually move the choke lever to the OPEN position.

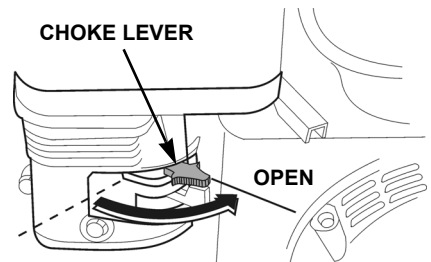

7. Set the throttle to the desired speed to produce the best pumping conditions.

Pump output can be controlled by adjusting the throttle lever to the desired position.

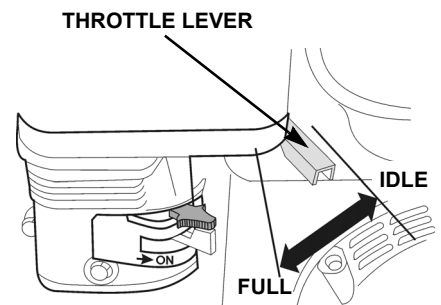

At FULL throttle position, the pump will deliver the highest output volume. Moving the throttle toward the IDLE position will decrease the output volume of the pump.

## STOPPING THE ENGINE

### Emergency

To stop the engine in an emergency, turn the ignition switch to the OFF position.

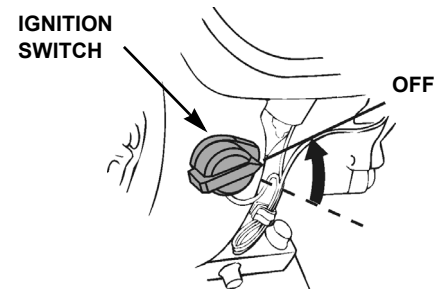

### Normal

1. Move the throttle lever fully to the right to the IDLE position.
2. Turn the ignition switch to the OFF position.
3. Turn the fuel valve to the OFF position.
4. After each use, drain the pump chamber and flush with fresh water (page 12).

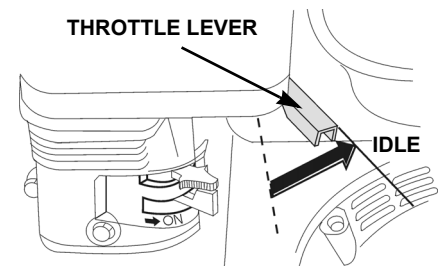

5. If your equipment will not be used for 3 to 4 weeks, we recommend running the engine's carburetor out of fuel. You can do this by leaving the fuel valve OFF, restarting the engine and running it out of fuel. See "STORAGE PREPARATION" on page 15 for periods of inactivity that exceed 4 weeks.

# SERVICING YOUR PUMP

Proper maintenance is essential for safe, economical, and trouble-free operation. It will also help reduce air pollution.

## ⚠ WARNING

Improper maintenance, or failure to correct a problem before operation, can cause a malfunction in which you can be seriously hurt or killed.

Always follow the inspection and maintenance recommendations and schedules in this owner's manual.

To help you properly care for your pump, the following pages include a maintenance schedule, routine inspection procedures, and simple maintenance procedures using basic hand tools. Other service tasks that are more difficult, or require special tools, are best handled by professionals and are normally performed by a Honda technician or other qualified mechanic.

The maintenance schedule applies to normal operating conditions. If you operate your pump under severe conditions, such as sustained high-load or high-temperature operation, or use in unusually wet or dusty conditions, consult your servicing dealer for recommendations applicable to your individual needs and use.

Remember that an authorized Honda servicing dealer knows your pump best and is fully equipped to maintain and repair it.

To ensure the best quality and reliability, use only new, Honda Genuine parts or their equivalents for repair and replacement.

**Maintenance, replacement, or repair of the emission control devices and systems may be performed by any engine repair establishment or individual, using parts that are "certified" to EPA standards.**

## MAINTENANCE SAFETY

Some of the most important safety precautions follow. However, we cannot warn you of every conceivable hazard that can arise in performing maintenance. Only you can decide whether or not you should perform a given task.

## ⚠ WARNING

Failure to properly follow maintenance instructions and precautions can cause you to be seriously hurt or killed.

Always follow the procedures and precautions in this owner's manual.

## Safety Precautions

- Make sure the engine is off before you begin any maintenance or repairs. This will eliminate several potential hazards:
  - **Carbon monoxide poisoning from engine exhaust.**  
Be sure there is adequate ventilation whenever you operate the engine.
  - **Burns from hot parts.**  
Let the engine and exhaust system cool before touching.
  - **Injury from moving parts.**  
Do not run the engine unless instructed to do so.
- Read the instructions before you begin, and make sure you have the tools and skills required.
- To reduce the possibility of fire or explosion, be careful when working around gasoline. Use only a nonflammable solvent, not gasoline, to clean parts. Keep cigarettes, sparks, and flames away from all fuel-related parts.

## MAINTENANCE SCHEDULE

Interval	Item
Before each use	Check the engine oil level (page 8) Check the air filter (page 9) Check pump hoses and strainer (page 12)
After each use	Flush the pump chamber (page 12)
First month or 20 hours	Change the engine oil (page 8) Grease the pump connecting rod bearing (page 12)
Every 3 months or 50 hours	Clean the air filter <sup>1</sup> (page 9) Clean the sediment cup (page 11) Grease the pump connecting rod bearing (page 12) Check the gear box oil level (page 12)
Every 6 months or 100 hours	Change the engine oil <sup>1</sup> (page 8) Inspect-adjust the spark plug (page 10) Clean-check the spark arrester (page 10) (optional equipment)
Every year or 300 hours	Change the engine oil <sup>1</sup> (page 8) Replace the air cleaner paper filter <sup>1</sup> (page 9) Replace the spark plug (page 10) Adjust the valve clearance <sup>2</sup> Adjust the idle speed <sup>2</sup> Clean the fuel tank and filter <sup>2</sup> Change the gear box oil (page 12) Inspect the pump clappet valve (page 13) Inspect the pump diaphragm (page 13) Check the torque of nuts and bolts
Every 2 years	Check the fuel line and replace if necessary <sup>2</sup>

1. Service more frequently when used in dusty areas.
2. These items should be serviced by an authorized Honda servicing dealer, unless you have the proper tools and are mechanically proficient.

Failure to follow this maintenance schedule could result in non-warrantable failures.

## ENGINE MAINTENANCE

### Engine Oil Level Check

Check the engine oil level with the engine stopped and in a level position.

1. Remove the filler cap/dipstick and wipe it clean.

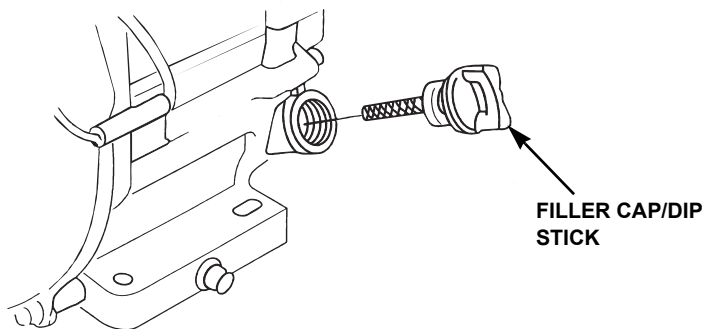

2. Insert and remove the dipstick without screwing it into the filler neck. Check the oil level shown on the dipstick.

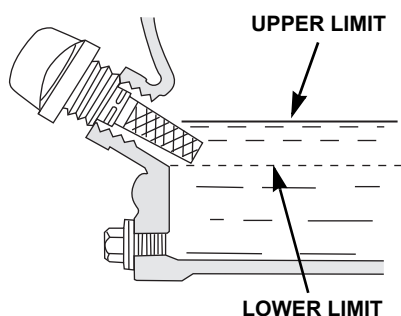

3. If the oil level is low, fill to the edge of the oil filler hole with the recommended oil, as shown on this page.
4. Screw in the filler cap/dipstick securely.

#### NOTICE

*Running the engine with a low oil level can cause engine damage.*

The Oil Alert® system will automatically stop the engine before the oil level falls below the safe limit. However, to avoid the inconvenience of an unexpected shutdown, always check the engine oil level before startup.

### Engine Oil Change

Drain the oil while the engine is warm. Warm oil drains quickly and completely.

1. Remove the filler cap/dipstick, drain bolt, and sealing washer. Drain the oil into a suitable container.

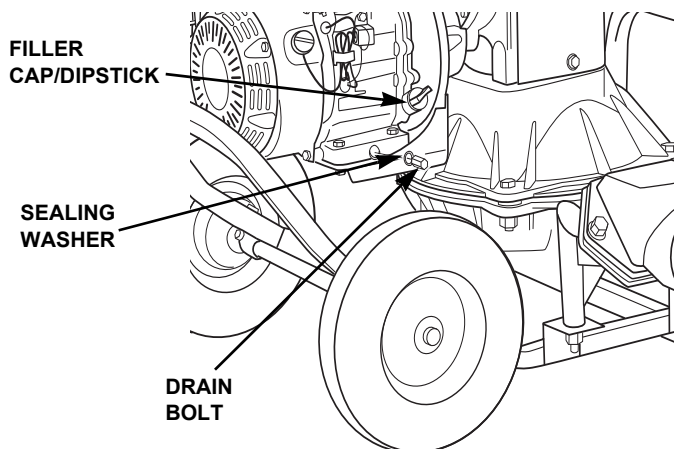

2. Reinstall the drain bolt and sealing washer. Tighten the bolt securely.

#### NOTICE

*Improper disposal of engine oil can be harmful to the environment. If you change your own oil, please dispose of the used oil properly. Put it in a sealed container, and take it to a recycling center. Do not discard it in a trash bin, dump it on the ground, or pour it down a drain.*

3. Place the pump on a level surface.
4. Fill with the recommended oil to the top edge of the oil filler hole.

**Quantity: 0.6 qt (0.6 L)**

5. Screw in the filler cap/dipstick securely.

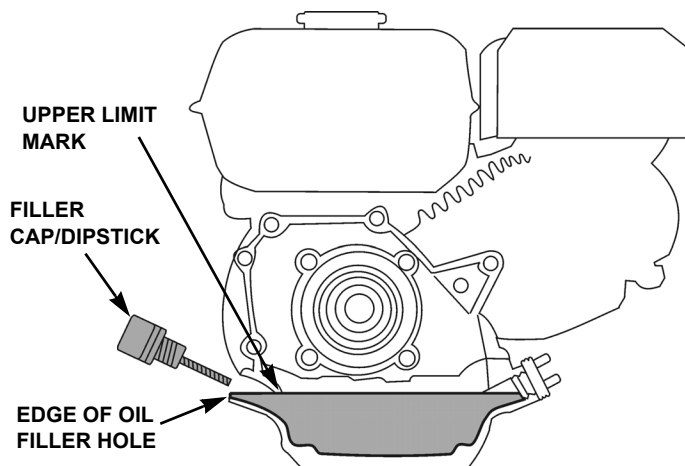

### Engine Oil Recommendations

Oil is a major factor affecting performance and service life. Always change the oil in accordance with the *MAINTENANCE SCHEDULE* (page 7).

SAE 10W-30 is recommended for general use. Other viscosities shown in the chart may be used when the average temperature in your area is within the recommended range.

The SAE oil viscosity and service category are in the API label on the oil container. Honda recommends that you use API service category SJ or later oil.

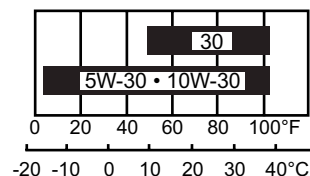

#### NOTICE

*Using non-detergent oil can shorten the engine's service life, and using 2-stroke oil can damage the engine.*



## Air Filter Inspection

1. Unscrew the outer wing nut and remove the air cleaner cover.

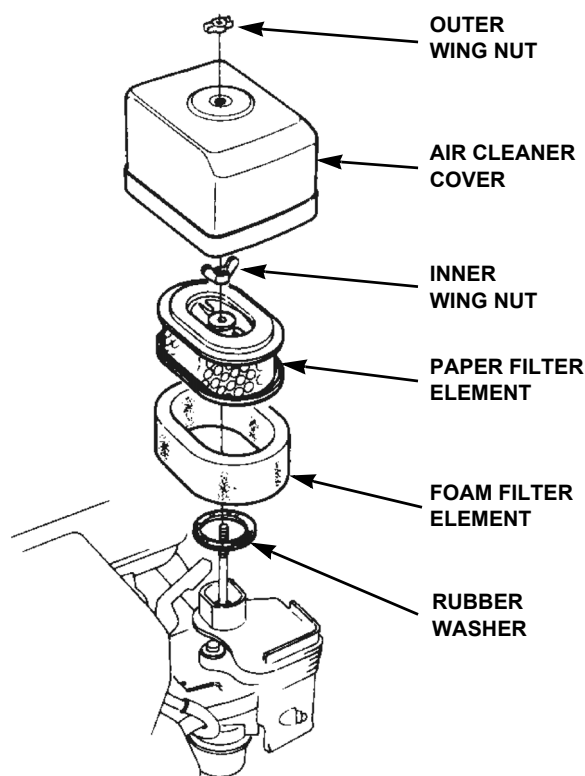

2. Remove the inner wing nut and both air filter elements.
3. Separate both air filter elements and carefully check them for holes or tears. Replace the filter elements if they are damaged.
4. If the air filter elements are dirty, clean them as described below.
5. Wipe dirt from the inside of the air cleaner housing and cover. Be careful to prevent dirt from entering the air duct that leads to the carburetor.
6. Install the foam element over the paper element, and install the assembled air filter. Secure the air filter with the inner wing nut. Make sure the rubber washer is in place under the filter elements.
7. Install the air cleaner cover, and secure with the outer wing nut.

### NOTICE

*Operating the engine without an air filter, or with a damaged air filter, will allow dirt to enter the engine, causing rapid engine wear. This type of damage is not covered by the DISTRIBUTOR'S LIMITED WARRANTY.*

## Air Filter Cleaning

A properly maintained air filter will help prevent dirt from entering your engine. Dirt entering the carburetor can be drawn into small passages in the carburetor and cause premature engine wear. These small passages can become blocked, causing starting or running problems. Always use an air filter specified for your engine to ensure it seals and performs as designed. You will need to clean the filter more frequently if you operate the engine in very dusty conditions.

1. To clean the paper filter element, tap the element lightly several times on a hard surface to remove excess dirt, or blow compressed air [not exceeding 30 psi (207 kPa)] through the filter element from the inside out.

Never try to brush the dirt off; brushing will force dirt into the paper fibers. Replace the paper element if it is excessively dirty or damaged.

2. To clean the foam filter element, wash the element in a solution of household detergent and warm water, then rinse thoroughly, or wash in nonflammable solvent.

SOLVENT



ENGINE OIL

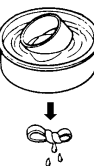

SQUEEZE THOROUGHLY

3. Allow the foam filter element to dry thoroughly.
4. Soak the foam filter element in clean engine oil and squeeze out the excess oil.

### NOTICE

*Excess oil will restrict air flow through the foam filter element and may transfer to the paper filter element, soaking and clogging it.*

5. Reassemble the air filter as shown.

## Spark Plug Service

Required Spark Plug: NGK - BPR6ES

### NOTICE

*Incorrect spark plugs can cause engine damage.*

For good performance, the spark plug must be properly gapped and free of deposits.

Allow the engine to cool before servicing the spark plug.

1. Disconnect the spark plug cap and remove any dirt from around the spark plug area.
2. Use a 13/16 in (21 mm) spark plug wrench to remove the spark plug.
3. Visually inspect the spark plug. Discard it if the insulator is cracked, chipped, or fouled.

SPARK PLUG WRENCH

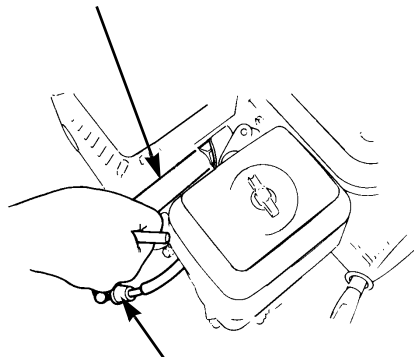

SPARK PLUG CAP

4. Measure the plug gap with a suitable gauge.

Correct as necessary by carefully bending the side electrode.

### Plug gap:

0.028 ~ 0.031 in  
(0.70 ~ 0.80 mm)

0.028 ~ 0.031 in  
(0.70 ~ 0.80 mm)

SEALING WASHER

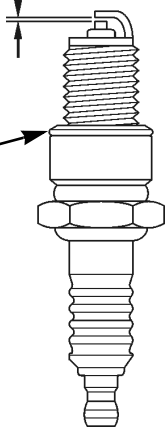

5. Check that the spark plug washer is in good condition, and thread the spark plug in by hand to prevent cross-threading.
6. After the spark plug is seated, tighten with a spark plug wrench to compress the washer.

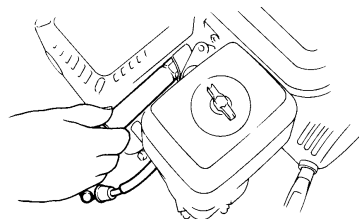

If installing a new spark plug, tighten 1/2 turn after the spark plug seats to compress the washer.

If reinstalling a used spark plug, tighten 1/8 - 1/4 turn after the spark plug seats to compress the washer.

### NOTICE

*A loose spark plug can overheat and damage the engine. Overtightening the spark plug can damage the threads in the cylinder head.*

7. Reconnect the spark plug cap.

## Spark Arrester (optional equipment)

The spark arrester must be serviced every 100 hours to keep it functioning as designed.

Your pump engine is not factory-equipped with a spark arrester. In some areas, it is illegal to operate an engine without a spark arrester. Check local laws and regulations. An optional USDA approved spark arrester is available from an authorized Honda servicing dealer. See [page 21](#) for part numbers.

If the engine has been running, the muffler will be very hot. Allow the muffler to cool before servicing the spark arrester.

1. Allow the engine to cool, then remove the two 8 mm nuts and remove the muffler from the cylinder head.
2. Remove the four 5 mm screws from the muffler protector and remove the muffler protector.
3. Remove the 4 mm screw from the spark arrester and remove the spark arrester from the muffler.

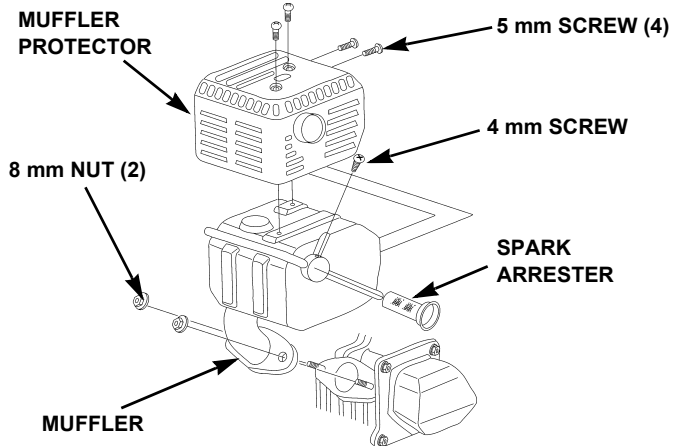

4. Use a stiff brush to remove carbon deposits from the spark arrester screen. Be careful not to damage the spark arrester screen.
5. Inspect the spark arrester for breaks and holes. Replace it if necessary.
6. Install the spark arrester and the muffler in the reverse order of disassembly.

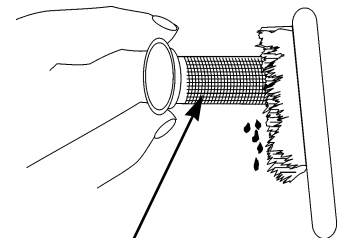

SPARK ARRESTER SCREEN

## Carburetor Adjustment

1. Start the engine outdoors and let it warm up to normal operating temperature.
2. Move the throttle lever to the idle position ([page 6](#)).
3. Using a screwdriver, turn the throttle stop screw to obtain the standard idle speed.

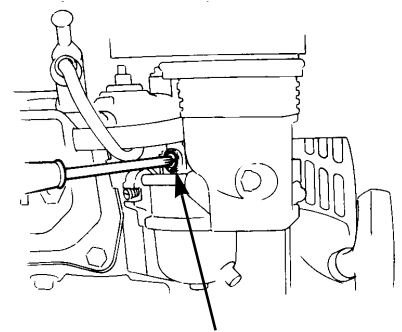

THROTTLE STOP SCREW

### Standard Idle Speed:

1,400 <sup>+200</sup><sub>-150</sub> rpm

## Sediment Cup Cleaning

1. Turn the fuel valve to the OFF position.
2. Remove the fuel sediment cup. **Do not remove the O-ring.** Confirm the O-ring is properly positioned and in good condition. Contact your authorized Honda dealer if the O-ring needs to be replaced.
3. Empty the contents of the sediment cup into a suitable container. Clean the fuel sediment cup with nonflammable solvent and dry it thoroughly.
4. Reinstall the sediment cup and tighten securely.

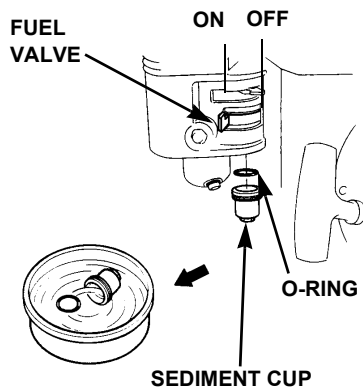

## REFUELING

This engine is certified to operate on unleaded gasoline with a pump octane rating of 86 or higher.

We recommend refueling after each use to minimize the air present in the fuel tank.

Refuel in a well-ventilated area with the engine stopped. If the engine has been running, allow it to cool first. Never refuel the engine inside a building where gasoline fumes may reach flames or sparks.

You may use regular unleaded gasoline containing no more than 10% ethanol (E10) or 5% methanol by volume. In addition, methanol must contain cosolvents and corrosion inhibitors. Use of fuels with content of ethanol or methanol greater than shown above may cause starting and/or performance problems. It may also damage metal, rubber, and plastic parts of the fuel system. In addition, ethanol is hygroscopic, which means it attracts and retains water in the fuel system. Engine damage or performance problems that result from using a fuel with percentages of ethanol or methanol greater than shown above are not covered by warranty.

If your equipment will be used on an infrequent or intermittent basis (more than 4 weeks before next use), refer to the *Fuel* section of the STORAGE chapter (page 15) for additional information regarding fuel deterioration.

### ⚠ WARNING

Gasoline is highly flammable and explosive.

You can be burned or seriously injured when handling fuel.

- Stop the engine and let it cool before refueling.
- Keep heat, sparks, and flames away.
- Handle fuel only outdoors.
- Wipe up spills immediately.

Never use stale or contaminated gasoline or an oil/gasoline mixture. Avoid getting dirt or water in the fuel tank.

To refuel, remove the fuel tank cap, and fill the tank with gasoline to the shoulder of the filler neck. Refuel carefully to avoid spilling fuel. Do not overfill.

After refueling, tighten the fuel tank cap securely.

Move the pump at least 10 feet (3 meters) away from the fueling source and site before starting the engine.

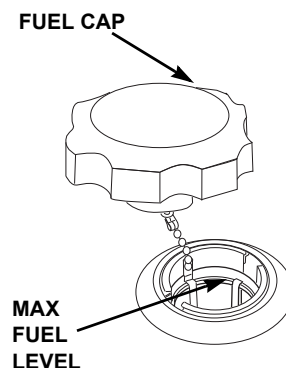

### NOTICE

*Fuel can damage paint and plastic. Be careful not to spill fuel when filling your fuel tank. Damage caused by spilled fuel is not covered by the DISTRIBUTOR'S LIMITED WARRANTY (page 22).*

### Fuel Storage Container

Store your gasoline in a clean, plastic, sealed container approved for fuel storage. Close the vent (if equipped) when not in use, and store the container away from direct sunlight. If it will take more than 3 months to use the fuel in the container, we suggest adding a fuel stabilizer to the fuel when you fill the container.

## PUMP MAINTENANCE

### Pump Chamber Flushing

With the engine stopped, the pump case should be flushed after each use to prevent sediment from building up in the case.

1. Disconnect the suction and discharge hoses.
2. Insert a garden hose into the suction side of the pump. Turn on the water and thoroughly flush sediment out the discharge side.

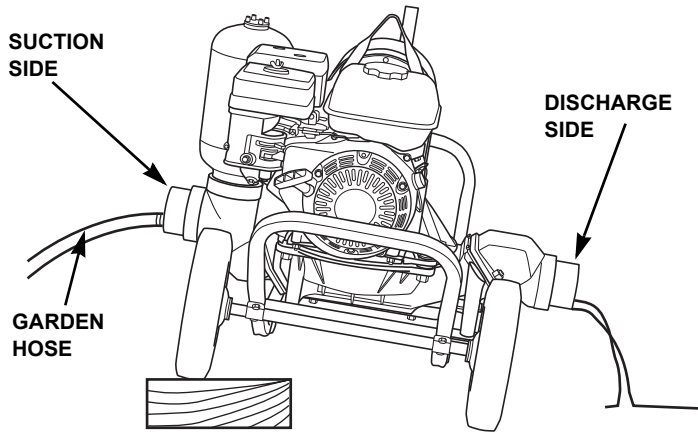

3. After flushing, lift the suction side of the pump and allow water to drain out the discharge side.

### Pump Hoses and Strainer

1. Check both hoses to make sure they are not torn or cracked. It is especially important that there are no tears in the suction hose. Tears or air leaks on the suction side will prevent the pump from priming properly.
2. Inspect the suction hose sealing washer to make sure it is in good condition.
3. Inspect the strainer to be sure it is not plugged or damaged.

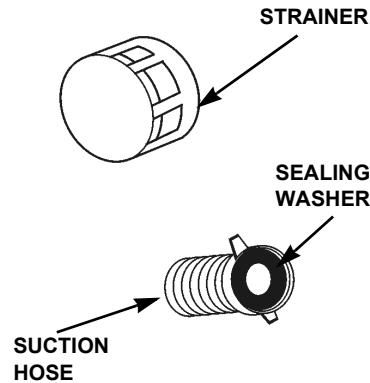

### Grease the Pump Connecting Rod

1. Remove the plastic access plug.
2. Disconnect the spark plug cap (page 10) and pull the starter grip until the grease fitting is visible in the access opening.
3. Wipe the grease fitting clean to prevent dirt from getting into the bearing. Using a manual grease gun, pump one or two strokes of NLGI #2 general purpose grease into the bearing.
4. Reinstall the access plug securely.

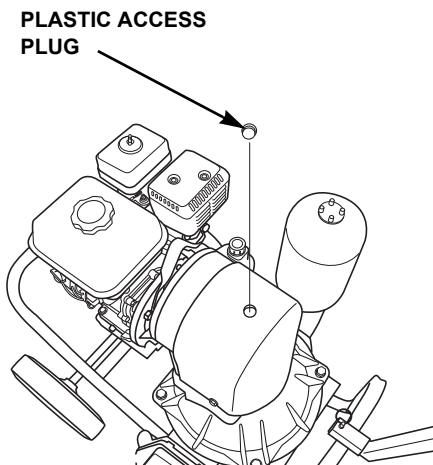

### Pump Gear Box Oil Change

1. Run the engine for 10 minutes to warm up the gear box oil. Warm oil drains quickly and completely.
2. Shut off the engine.
3. Remove the two 8 x 15 mm bolts and washers from the connecting rod cover and remove the cover.

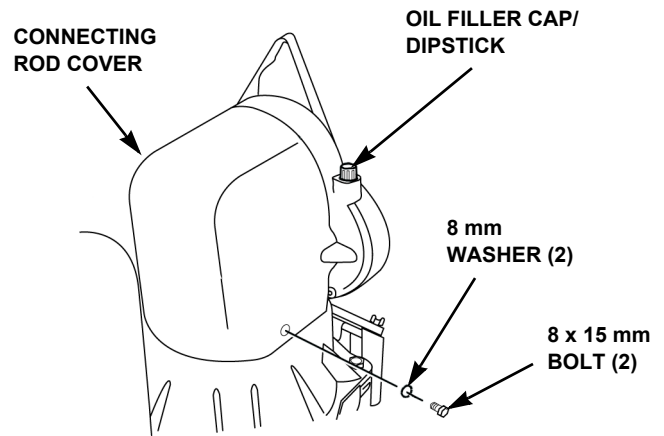

4. Remove the drain bolt and drain the gear oil from the gear box.

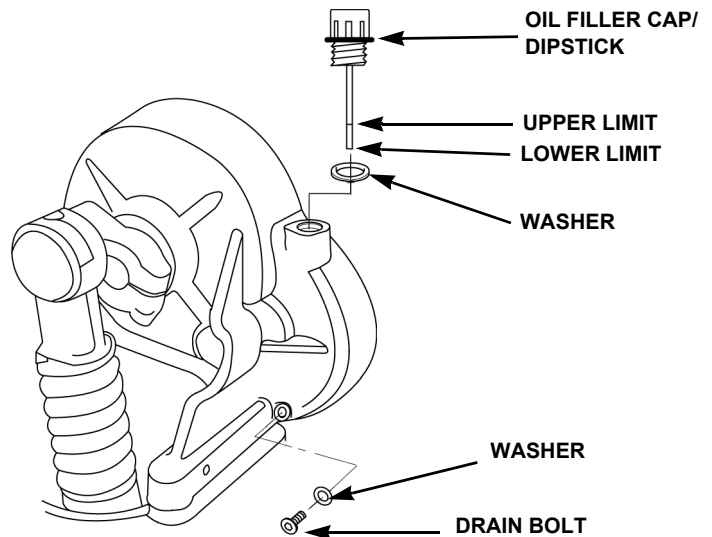

5. Replace the drain bolt washer and reinstall the drain bolt.
6. Fill the gear box to the upper limit on the oil filler cap/dipstick. **Do not overfill.** Screw the dipstick in to measure the oil level.

**Recommended oil: SAE 80W/90 GL5 Gear oil**

7. Dispose of the used oil properly (page 8).
8. Reinstall the connecting rod cover.

#### NOTICE

Avoid getting gear oil on the diaphragm. Drain the oil into a drain pan to prevent oil from running down the pump case onto the diaphragm. If gear oil comes in contact with the diaphragm, the diaphragm will be damaged.

### Pump Gear Box Oil Check

With the pump cold and on a level surface, remove the oil filler cap/dipstick. The oil level should be just below the UPPER LIMIT mark on the dipstick. Screw the dipstick in to check the oil level.

## Pump Clappet Valves

1. Disconnect the spark plug cap from the spark plug (page 3).
2. Turn the fuel valve lever to the OFF position (page 3).
3. Flush the pump chamber (page 12).
4. Lift the suction side of the pump and allow all the water to drain out the discharge fitting.
5. Use a 19 mm wrench and remove the nuts and flat washers from both the suction and discharge ports.

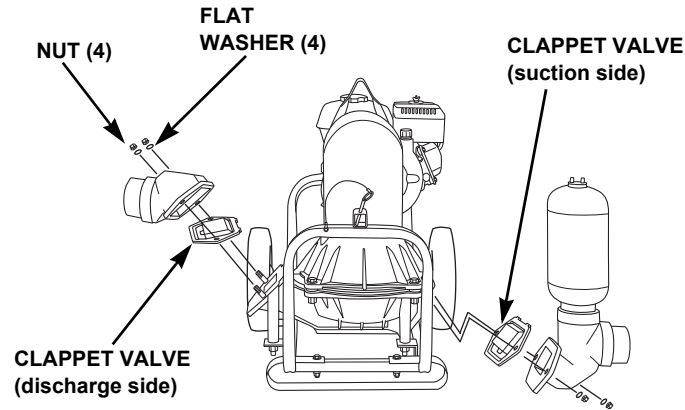

6. Remove both ports. The clappet valves are directional, so when removing the valves, note the water flow direction.
7. Inspect the ports, case sealing surfaces, and clappets for damage. If the clappets are worn, torn, or damaged, replace them. If the case sealing surface is damaged and cannot be cleaned, an optional wear plate and gasket is available from your Honda water pump dealer (page 21).
8. Install the clappet valves over the studs. On the discharge side, install the flat side of the valve facing the pump housing. On the suction side, install the flat side of the valve facing the port.

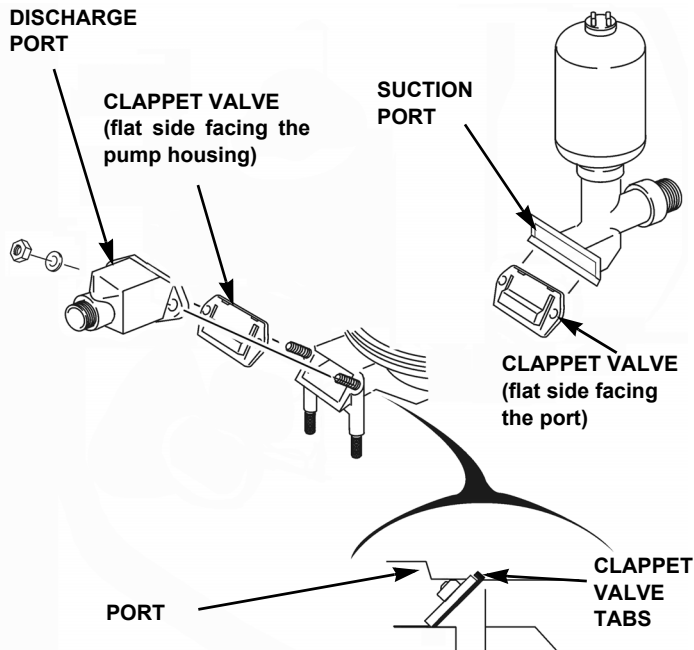

9. Install both ports, making sure all clappet valve tabs are positioned correctly.
10. Apply several drops of Hondalock 2 or equivalent thread lock to the stud threads. Hand tighten the nuts, then torque evenly. **TORQUE: 20 ft-lb (27 N·m)**

11. After tightening the nuts, insert a screwdriver into each port and check clappet valve operation. Clappets should operate freely and should seal when released. If a clappet does not operate properly, reinstall the clappet and recheck.

12. Run the pump and check for leaks.

## Pump Diaphragm Disassembly

1. Disconnect the spark plug cap from the spark plug (page 3).
2. Drain the fuel tank (page 16). Flush the pump chamber (page 12).
3. Remove the plastic connecting rod cover (page 12). Pull the starter grip to rotate the connecting rod to the down position.
4. Remove the 4 nuts, washers, bolts, and the upper pump assembly using a 19 mm wrench. Place the upper pump and engine assembly to the side.

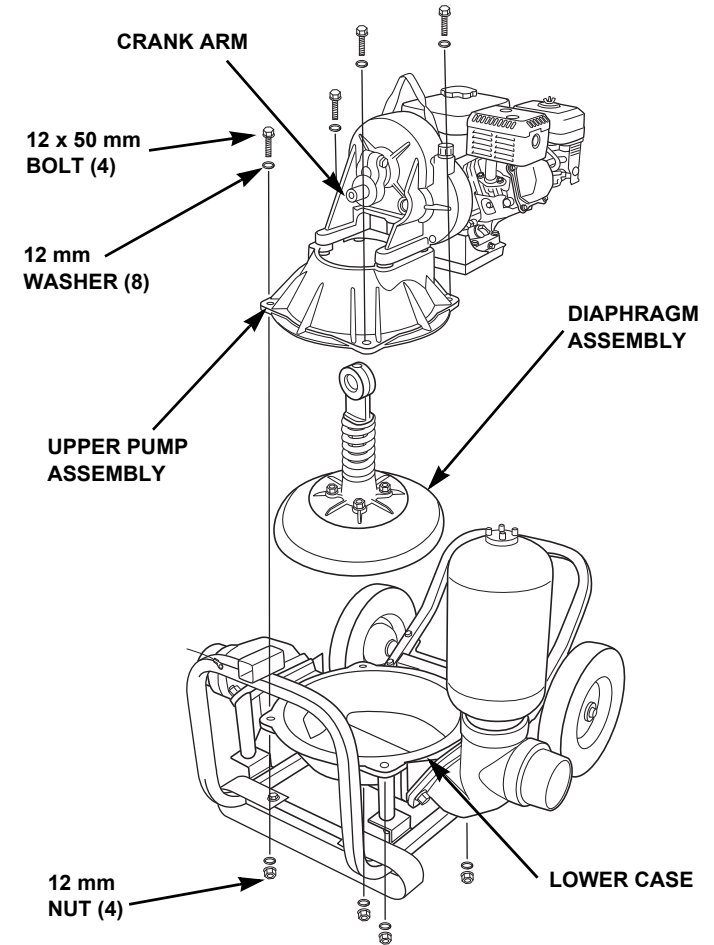

5. Use a 17 mm wrench and remove the bolt securing the connecting rod to the crank arm. Wipe the rod surface clean and use a felt tip marker to mark the outside of the connecting rod for reassembly.

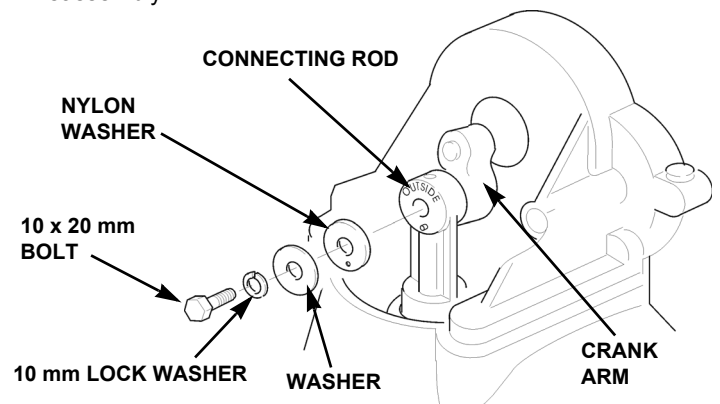

6. If the diaphragm is to be reused, mark the diaphragm to allow it to be installed in the same position.

7. With a 19 mm wrench, remove the 4 nuts securing the connecting rod to the lower flange. Remove the diaphragm.

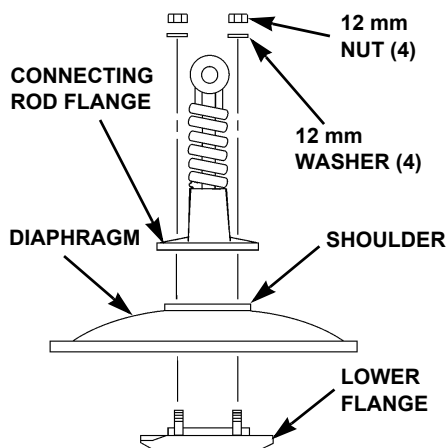

8. Inspect the diaphragm for cracks, tears, or damage and replace it if necessary.

### Pump Diaphragm Reassembly

During reassembly, note the following:

- Apply several drops of Hondalock 2 or equivalent thread lock to the bolt threads.
- To prevent pump case and/or diaphragm damage, follow the torque sequence shown below.

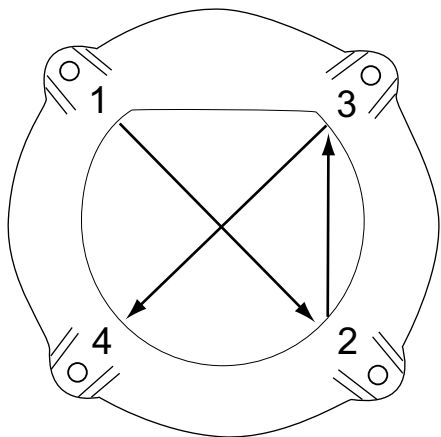

### TORQUE:

Start in one corner, increasing the amount of torque 1/8 to 1/4 turn each time around until the specified torque is achieved.

**Diaphragm flange nuts                      35 ft-lb (47 N•m)**

### NOTICE

*The pump case and/or diaphragm may be damaged if the torque sequence is not followed or the nuts are overtightened.*

1. Position the diaphragm between the connecting rod flange and the lower flange, then install the nuts and washers. Note the diaphragm shoulder on top.
2. Apply NLGI #2 general purpose grease to the connecting rod bearing ([page 12](#)).
3. Rotate the crank arm to the bottom by pulling the starter grip. Install the diaphragm and connecting rod into the pump case, then install the connecting rod with the mark made during disassembly facing out.

4. Install the connecting rod with the hardware shown below and torque the connecting rod bolt to **40 ft-lb (54 N•m)**.

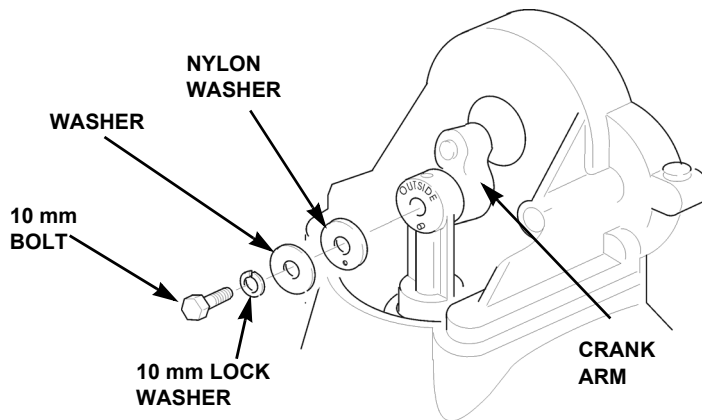

5. Pull the starter grip slowly until the diaphragm pulls up against the upper case stops.

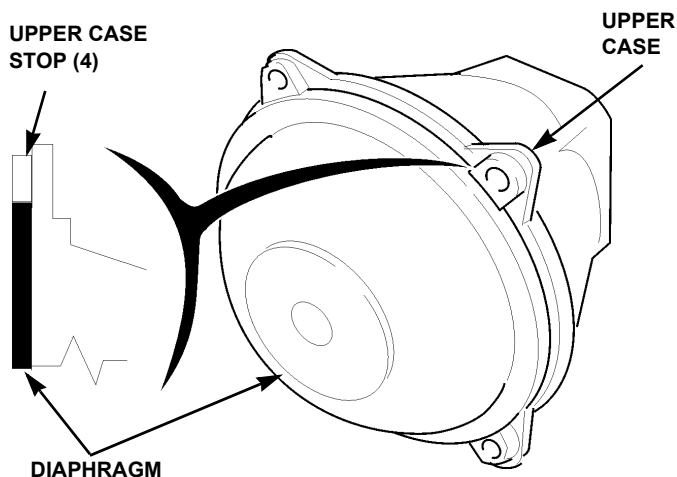

The crank arm should be approximately at the angle shown below.

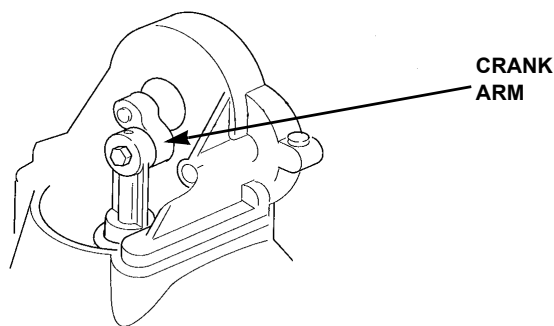

6. Install the upper case assembly, making sure the diaphragm is centered and not pinched between the case stops. Tighten the hardware following the torque procedure shown.

**Pump case bolts                                      35 ft-lb (47 N•m)**

**Connecting rod bolt                                40 ft-lb (54 N•m)**

7. Grease the pump connecting rod and install the connecting rod cover ([page 12](#)).
8. Run and test the pump for correct operation.

# TRANSPORTING

## BEFORE LOADING

When transporting the pump, be sure to keep it upright. If the pump is tilted or overturned, fuel may spill from the tank, which can result in a fire hazard.

Allow the engine to cool before transporting the pump.

1. Turn the ignition switch to the OFF position.

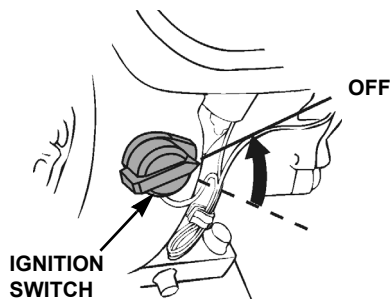

2. Turn the fuel valve to the OFF position.
3. Drain the pump chamber (page 12).

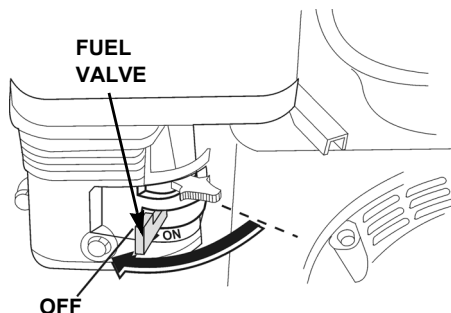

## LOADING AND UNLOADING

Roll the pump on a ramp or use a hoist connected to the lifting bracket to load the pump on and off the transport vehicle.

Position the pump so it is level on the transport vehicle. Tie the pump down with rope or straps attached to the frame, and place blocks in front and behind the wheels to prevent rolling. Keep the tie-down rope or straps away from the controls and carburetor.

# STORAGE

## STORAGE PREPARATION

Proper storage preparation is essential for keeping your pump trouble free and looking good. To help keep rust and corrosion from impairing your pumps function and appearance, and to make the engine easier to start after storage, follow the instructions described in this section to:

- Clean the pump and engine
- Drain or treat the fuel
- Change the oil and coat the engine cylinder
- Choose a storage location

### Cleaning the Engine

Wash the engine by hand, and be careful to prevent water from entering the air cleaner or muffler.

#### NOTICE

- Using a garden hose or pressure washing equipment can force water into the air cleaner. Water in the air cleaner will soak the filter and can enter the carburetor or engine, causing damage.
- Water contacting a hot engine can cause damage. If the engine has been running, allow it to cool for at least half an hour before washing.

### Cleaning the Pump

1. Flush the pump chamber (page 12).
2. Wash the pump with a garden hose or other low pressure equipment. Keep water away from controls and all other places that are difficult to dry, as water may promote rust.
3. After washing, remove as much standing water as possible with a dry cloth. Start the engine outdoors and let it run until it reaches normal operating temperature to evaporate any water remaining on the engine.
4. Stop the engine and allow it to cool.
5. After the pump is clean and dry, touch up any damaged paint, and coat other areas that may rust with a light film of oil. Lubricate controls with a silicone spray lubricant.

### Fuel

#### NOTICE

Depending on the region where you operate your equipment, fuel formulations may deteriorate and oxidize rapidly. Fuel deterioration and oxidation can occur in as little as 30 days and may cause damage to the carburetor and/or fuel system. Please check with your servicing dealer for local storage recommendations.

Gasoline will oxidize and deteriorate in storage. Deteriorated gasoline will cause hard starting, and it leaves gum deposits that can clog the small passages in the fuel system. If the gasoline in your engine deteriorates during storage, you may need to have the carburetor, and other fuel system components, serviced or replaced.

The length of time that gasoline can be left in your fuel tank and carburetor without causing functional problems will vary with such factors as gasoline blend, your storage temperatures, and whether the fuel tank is partially or completely filled. The air in a partially filled fuel tank promotes fuel deterioration. Very warm storage temperatures accelerate fuel deterioration. Fuel problems may occur within a month of inactivity, or even less if the gasoline was not fresh when you filled the fuel tank.

If you keep a container of gasoline for refueling, be sure that it contains only fresh gasoline.

See "AVOIDING FUEL-RELATED PROBLEMS" on page 20 for a list of recommended procedures to avoid fuel related problems.

Fuel system damage or engine performance problems resulting from neglected storage preparation are not covered under the *Distributor's Limited Warranty* (page 22).

### Draining the Fuel Tank and Carburetor

1. Remove the carburetor drain screw with a 10 mm wrench or screwdriver, and drain the fuel into an approved gasoline container.

## ⚠ WARNING

Gasoline is highly flammable and explosive.

You can be burned or seriously injured when handling fuel.

- Stop the engine and let it cool before handling fuel.
- Keep heat, sparks, and flame away.
- Handle fuel only outdoors.
- Wipe up spills immediately.

2. Turn the fuel valve to the ON position. This will allow fuel in the fuel tank to drain through the carburetor bowl.

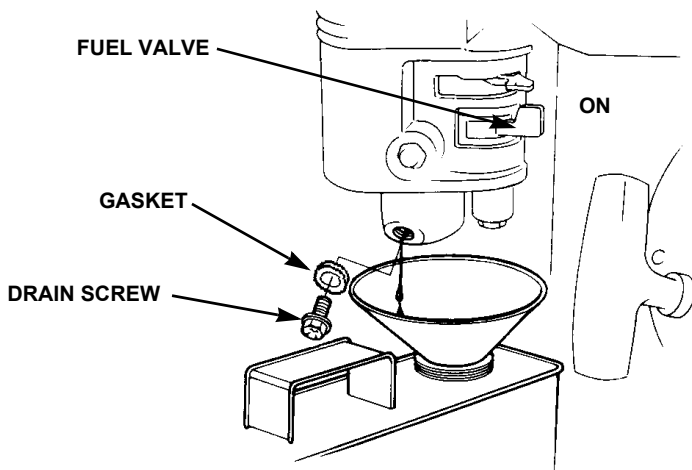

3. After all fuel has drained, reinstall the drain screw and gasket.

4. Turn the fuel valve to the OFF position.

5. Remove the fuel sediment cup. **Do not remove the O-ring.** Confirm the O-ring is properly positioned and in good condition. Contact your authorized Honda dealer if the O-ring needs to be replaced.

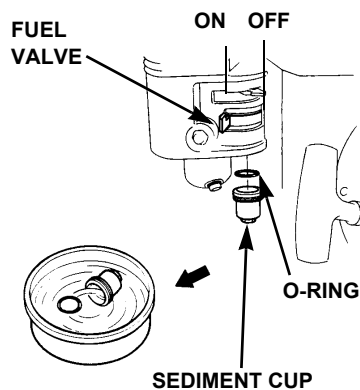

6. Empty the contents of the sediment cup into a suitable container. Clean the fuel sediment cup with nonflammable solvent and dry it thoroughly.

7. Reinstall the sediment cup and tighten securely.

## Engine Oil

1. Change the engine oil (page 8).
2. Check the air filter and clean as necessary (page 9).
3. Remove the spark plug (page 10).
4. Pour a tablespoon (5 - 10 cc) of clean engine oil into the cylinder.
5. Slowly pull the starter grip a few times to distribute the oil in the cylinder.
6. Reinstall the spark plug.
7. Pull the starter grip slowly until resistance is felt. Continue pulling slowly until the arrow notch on the starter pulley aligns with the hole on the recoil starter. Return the starter grip gently. This will close the valves so moisture cannot enter the engine cylinder.

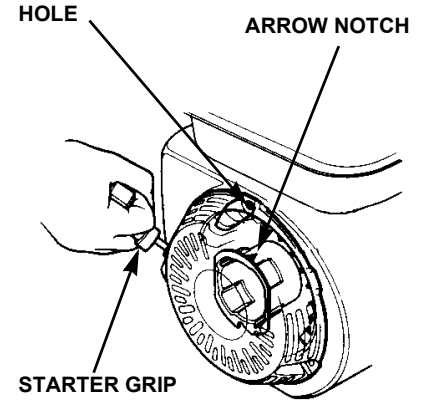

## PLACING IN STORAGE

If your pump will be stored with gasoline in the fuel tank and carburetor, it is important to reduce the hazard of gasoline vapor ignition. Select a well-ventilated storage area away from any appliance that operates with a flame, such as a furnace, water heater, or clothes dryer. Also avoid any area with a spark producing electric motor, or where power tools are operated.

If possible, avoid storage areas with high humidity, because that promotes rust and corrosion.

Unless all fuel has been drained from the fuel tank, leave the fuel valve in the OFF position to reduce the possibility of fuel leakage.

Place the pump on a level surface. Tilting can cause fuel or oil leakage.

With the engine and exhaust system cool, cover the pump to keep out dust. A hot engine and exhaust system can ignite or melt some materials.

Do not use sheet plastic as a dust cover. A nonporous cover will trap moisture around the pump, promoting rust and corrosion.

## REMOVAL FROM STORAGE

Check your pump as described in *BEFORE OPERATION* (page 3).

If the fuel was drained during storage preparation, fill the tank with fresh gasoline. If you keep a container of gasoline for refueling, be sure that it contains only fresh gasoline. Gasoline oxidizes and deteriorates over time, causing hard starting.

If the cylinder was coated with oil during storage preparation, the engine may smoke briefly at startup. This is normal.



# TAKING CARE OF UNEXPECTED PROBLEMS

## Engine Will Not Start

Possible Cause	Correction
Ignition switch OFF	Turn the ignition switch ON (page 6).
Fuel valve OFF	Turn the fuel valve ON (page 6).
Choke lever in the wrong position	Move the choke lever to the CHOKE position, unless the engine is warm (page 6).
Throttle lever in the wrong position	Move the throttle lever slightly to the left (page 6).
Out of fuel	Refuel (page 11).
Bad fuel; pump stored without treating or draining gasoline, or refueled with bad gasoline	Drain the fuel tank and carburetor (page 16). Refuel with fresh gasoline (page 11).
Spark plug faulty, fouled, or improperly gapped	Gap or replace the spark plug (page 10).
Spark plug wet with fuel (flooded engine)	Dry and reinstall the spark plug.
Fuel filter clogged, carburetor malfunction, ignition malfunction, valves stuck, etc.	Take the pump to an authorized Honda servicing dealer for repair.

## Pump Will Not Pump

Possible Cause	Correction
Strainer clogged	Clear strainer (page 5).
Restriction or foreign material in pump casing	Clear restriction (page 5).
Suction hose clamps loose	Tighten hose clamps (page 5).
Suction hose sealing washer not installed	Install suction hose sealing washer (page 5).
Suction hose or suction hose nipple face damaged	Replace damaged parts (page 5).
Suction head is too high	Locate pump at appropriate level (page 19).
Pump requires priming	Prime the pump (page 5).
Debris under the clappet valve or damaged clappet valve	Remove debris or replace clappet valve (page 13).
Diaphragm is torn	Replace diaphragm (page 13).
Pump still does not pump	Take the pump to an authorized Honda servicing dealer for repair.

# TECHNICAL INFORMATION

## SERIAL NUMBER LOCATIONS

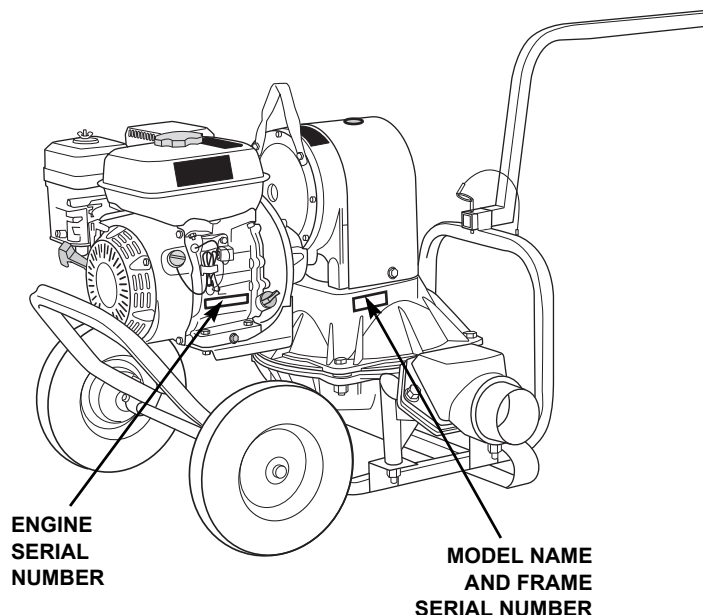

There are two serial numbers, one for the engine and one for the frame. Record the engine and frame serial numbers in the space below. You will need these serial numbers when ordering parts and when making technical or warranty inquiries.

Engine serial number: \_\_\_\_\_

Frame serial number: \_\_\_\_\_

Date of purchase: \_\_\_\_\_

## CARBURETOR MODIFICATION FOR HIGH ALTITUDE OPERATION

At high altitude, the standard carburetor air-fuel mixture will be too rich. Performance will decrease, and fuel consumption will increase. A very rich mixture will also foul the spark plug and cause hard starting. Operation at an altitude that differs from that at which this engine was certified, for extended periods of time, may increase emissions.

High altitude performance can be improved by specific modifications to the carburetor. If you always operate your pump at altitudes above 5,000 feet (1,500 meters), have your servicing dealer perform this carburetor modification. This engine, when operated at high altitude with the carburetor modifications for high altitude use, will meet each emission standard throughout its useful life.

Even with carburetor modification, engine horsepower will decrease about 3.5% for each 1,000-foot (300-meter) increase in altitude. The effect of altitude on horsepower will be greater than this if no carburetor modification is made.

### NOTICE

*When the carburetor has been modified for high altitude operation, the air-fuel mixture will be too lean for low altitude use. Operation at altitudes below 5,000 feet (1,500 meters) with a modified carburetor may cause the engine to overheat and result in serious engine damage. For use at low altitudes, have your servicing dealer return the carburetor to original factory specifications.*

# EMISSION CONTROL SYSTEM

## Source of Emissions

The combustion process produces carbon monoxide, oxides of nitrogen, and hydrocarbons. Control of hydrocarbons and oxides of nitrogen is very important because, under certain conditions, they react to form photochemical smog when subjected to sunlight. Carbon monoxide does not react in the same way, but it is toxic.

Honda utilizes appropriate air/fuel ratios and other emissions control systems to reduce the emissions of carbon monoxide, oxides of nitrogen, and hydrocarbons. Additionally, Honda fuel systems utilize components and control technologies to reduce evaporative emissions.

## The U.S. and California Clean Air Acts

U.S. EPA and California regulations require all manufacturers to furnish written instructions describing the operation and maintenance of emissions control systems.

The following instructions and procedures must be followed in order to keep the emissions from your Honda engine within the emissions standards.

## Tampering and Altering

### NOTICE

*Tampering is a violation of federal and California law.*

Tampering with or altering the emissions control system may increase emissions beyond the legal limit. Among those acts that constitute tampering are:

- Removal or alteration of any part of the intake, fuel, or exhaust systems.
- Altering or defeating the speed-adjusting mechanism to cause the engine to operate outside its design parameters.

## Problems That May Affect Emissions

If you are aware of any of the following symptoms, have your engine inspected and repaired by your servicing dealer.

- Hard starting or stalling after starting
- Rough idle
- Misfiring, backfiring under load, or afterburning
- Black exhaust smoke or high fuel consumption

## Replacement Parts

The emissions control systems on your new Honda engine were designed, built, and certified to conform with EPA and California emissions regulations. We recommend the use of Honda Genuine parts whenever you have maintenance done. These original-design replacement parts are manufactured to the same standards as the original parts, so you can be confident of their performance. Honda cannot deny coverage under the emission warranty solely for the use of non-Honda replacement parts or service performed at a location other than an authorized Honda dealership; you may use comparable EPA certified parts, and have service performed at non-Honda locations. However, the use of replacement parts that are not of the original design and quality may impair the effectiveness of your emissions control system.

A manufacturer of an aftermarket part assumes the responsibility that the part will not adversely affect emissions performance. The manufacturer or rebuilder of the part must certify that use of the part will not result in a failure of the engine to comply with emissions regulations.

## Maintenance

As the power equipment engine owner, you are responsible for completing all required maintenance listed in your owner's manual. Honda recommends that you retain all receipts covering maintenance on your power equipment engine, but Honda cannot deny warranty coverage solely for the lack of receipts or for your failure to ensure that all scheduled maintenance has been completed.

Follow the *Maintenance Schedule* on [page 7](#). Remember this schedule is based on the assumption that your machine will be used for its designed purpose. Sustained high-load or high-temperature operation, or use in unusually wet or dusty conditions, will require more frequent service.

## AIR INDEX

An Air Index Information hang tag/label is applied to engines certified to an emission durability time period in accordance with the requirements of the California Air Resources Board.

The bar graph is intended to provide you, our customer, the ability to compare the emissions performance of available engines. The lower the Air Index, the less pollution.

The durability description is intended to provide you with information relating to the engine's emission durability period. The descriptive term indicates the useful life period for the engine's emission control system. See your *EMISSION CONTROL SYSTEM WARRANTY* ([page 23](#)) for additional information.

Descriptive Term	Applicable to Emission Durability Period
Moderate	50 hours (0–80 cc inclusive) 125 hours (greater than 80 cc)
Intermediate	125 hours (0–80 cc inclusive) 250 hours (greater than 80 cc)
Extended	300 hours (0–80 cc inclusive) 500 hours (greater than 80 cc) 1000 hours (225 cc and greater)

## SPECIFICATIONS

### Dimensions and Weight

Model	WDP30XK2AT
Description code	WZCA
Length x Width x Height [with handlebar over engine]	31.5 x 30.5 x 25.7 in (800 x 775 x 654 mm)
Dry weight	163 lbs (73.9 kg)

### Engine Design and Performance

Model	GX120T2QX2
Engine type	4-stroke, overhead-valve, single cylinder
Displacement [bore x stroke]	7.2 cu in (118 cc) [2.4 x 1.7 in (60 x 42 mm)]
Oil capacity	0.6 qt (0.6 L)
Fuel capacity	0.53 US gal (2.0 L)
Cooling system	Forced air
Ignition system	Transistorized magneto
PTO shaft direction	Counterclockwise

## Pump

Pump type	Diaphragm with spring-type connecting rod
Suction port diameter/thread type	3 in/NPT
Discharge port diameter/thread type	
Maximum total head	50 ft (15 m)
Maximum suction head (dry)	16 ft (4.9 m)
Maximum suction head (after priming pump housing)	24 ft (7.3 m)
Maximum discharge capacity	80 gpm (303 L/min)
Self-priming time	20 sec at 20 ft (6.1 m)
Maximum solid size	2.4 in (60 mm)
Diaphragm	Neoprene with nylon cloth
Valves	Neoprene with cast iron inserts

## Gear Box

Pump operating frequency	73 strokes/min.
Gear reduction	43:1
Pump stroke	2.77 in (70.4 mm)
Gear box oil capacity	0.8 qt (0.8 L)

## Maintenance

Fuel	Unleaded gasoline with a pump octane rating of 86 or higher	See <a href="#">page 11</a>
Engine oil	SAE 10W-30 API SJ, or later	See <a href="#">page 8</a>
Gear box oil	SAE 80W/90 GL5 gear oil	See <a href="#">page 12</a>
Spark plug type	NGK- BPR6ES DENSO- W20EPR-U	See <a href="#">page 10</a>
Maximum engine speed (no load)	3,100 ~ 3,250 rpm	

## Tune-up

Spark plug gap	0.028 ~ 0.031 in (0.70 ~ 0.80 mm)	See <a href="#">page 10</a>
Carburetor idle speed	1,400 <sup>+200</sup> / <sub>-150</sub> rpm	See <a href="#">page 10</a>
Valve clearance (cold)	Intake: 0.15 ± 0.02 mm Exhaust: 0.20 ± 0.02 mm	See your authorized Honda servicing dealer
Other specifications	No other adjustments needed	

## Pump Performance Curve

This graph shows the relationship between the pump discharge capacity and the total dynamic head, based on clear water at sea level. As you increase the total head, the discharge capacity will decrease.

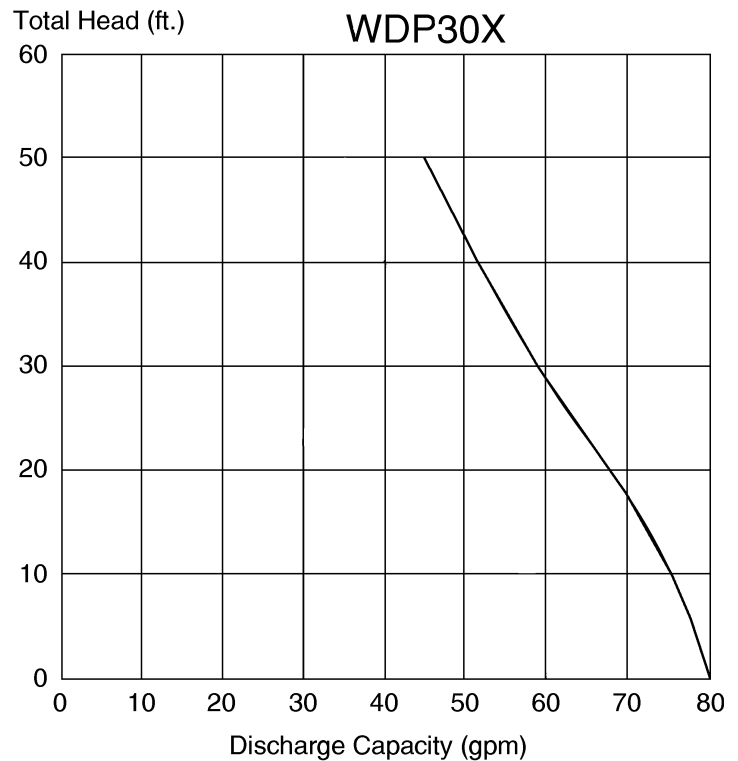

## Wiring Diagram

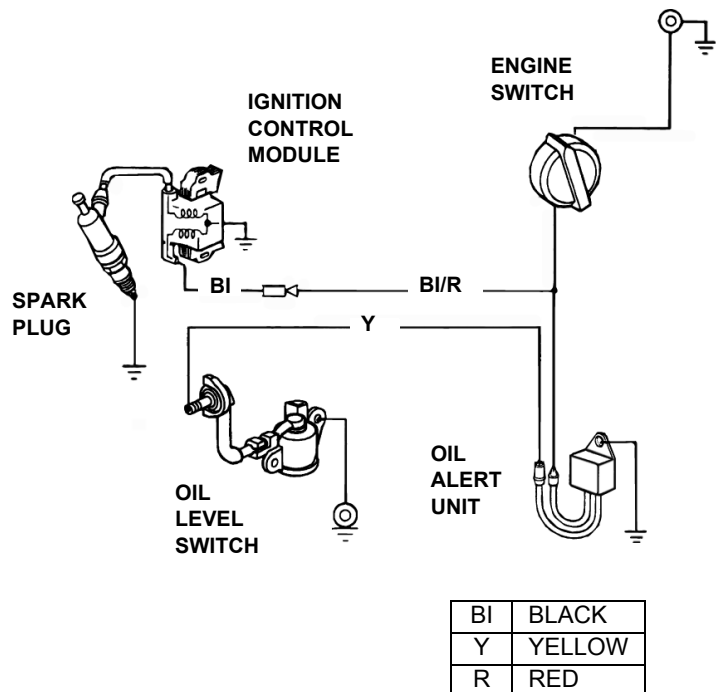

# AVOIDING FUEL-RELATED PROBLEMS

When properly maintained, your Honda pump should provide years of trouble-free operation. This includes the fuel system. However, gasoline can quickly deteriorate (in as little as 30 days) causing starting or running problems and, in some cases, damage to the fuel system. Most fuel-related problems can be avoided by following the precautions listed below. Fuel system damage and engine performance problems resulting from deteriorated gasoline are not covered by the *DISTRIBUTOR'S LIMITED WARRANTY* (see [page 22](#)).

## Follow These Precautions to Prevent Most Fuel-Related Problems

During the Normal Season	Reason
Do not use gasoline containing more than 10% ethanol (E10). Not all automotive gasoline is safe to use in your pump.	Higher levels of ethanol in gasoline attract water, and can corrode or damage the fuel system and cause performance problems.
Store gasoline in a clean, plastic, sealed container approved for fuel storage. Store your fuel supply container away from direct sunlight; if the container has a vent, keep it closed.	A plastic container eliminates the risk of rust and metallic contaminants from a metal container entering the fuel system. Gasoline will deteriorate faster when exposed to air and sunlight.
Purchase only enough gasoline to last for 1 to 2 months (about 30 to 60 days). If you purchase enough gasoline to last for more than 60 days, add a fuel stabilizer to your storage container when you fill it.	Gasoline deteriorates with age so try to avoid storing it for long periods, especially in summer heat. Fuel stabilizer will extend the shelf life of gasoline, but it will not reconstitute stale fuel.
Keep your pump's fuel tank full of fresh fuel when not in use. Turn the fuel valve OFF.	If the fuel tank is only partially filled, air in the tank will promote fuel deterioration.

3 to 4 Weeks Before Next Use	Reason
Keep your pump's fuel tank full of fresh fuel when not in use. Turn the fuel valve OFF.	If the fuel tank is only partially filled, air in the tank will promote fuel deterioration.

1 to 3 Months Before Next Use	Reason
If you did not add fuel stabilizer to your fuel storage container when you filled it up, fill your pump's fuel tank with fresh gasoline.	If the fuel tank is only partially filled, air in the tank will promote fuel deterioration.
Add fuel stabilizer to the pump's fuel tank according to the stabilizer manufacturer's instructions.	Fuel stabilizer will extend the life of gasoline, but it will not reconstitute stale gasoline.
Run the engine outdoors for 10 minutes.	To make sure treated gasoline has replaced untreated gasoline throughout the fuel system.

More Than 3 Months Before Next Use	Reason
Drain the fuel tank into an approved container, and then run the engine until the engine stops. Do not allow gasoline to remain in your pump for more than 3 months of inactivity.	All fuel stabilizers have a shelf life. It is good practice to empty the fuel system for long term inactivity.

We recommend Pro Honda Fuel Stabilizer, that has improved formulation with added corrosion protection ([page 21](#)).

# CONSUMER INFORMATION

## REPLACEMENT PARTS, OPTIONAL EQUIPMENT, AND SERVICE ITEMS

Contact an authorized Honda servicing dealer to purchase any of these (or other) genuine, original Honda items for your pump.

### Replacement Parts

Item	Part Number	Notes
Spark plug	98079-56876	NGK (brand) BPR6ES
Air filter	17210-ZE0-505	Complete element

### Optional Equipment

Item	Part Number	Notes
Spark arrester	18355-ZE1-000	Arrester
	90055-ZE1-000	Screw
Pin lug hose kit	124030-1148-PINKT	Each kit includes: 20' suction hose, 50' discharge hose, Steel strainer (3/8" hole)
Camlock hose kit	124030-1148-CLKT	
No-Spill gas can	06176-1450C	5 gal
Wearplate	Q14-0000-065WP	Stainless steel wearplate and paper gasket (2 wearplates and gaskets required)
Gasket	Q14-0000-065P	

### Service Items

Item	Part Number	Notes
SAE 10W-30 engine oil	08207-10W30	Honda Genuine recommended oil
Fuel stabilizer	08732-0800	For long term storage

## DEALER LOCATOR INFORMATION



To find an Authorized Honda Servicing Dealer anywhere in the United States:

Visit our website:

[powerequipment.honda.com](http://powerequipment.honda.com) and click on Find a Dealer.

## CUSTOMER SERVICE INFORMATION

Honda Power Equipment dealership personnel are trained professionals. They should be able to answer any question you may have. If you encounter a problem that your dealer does not solve to your satisfaction, please discuss it with the dealership's management. The Service Manager or General Manager can help. Almost all problems are solved in this way.

If you are dissatisfied with the decision made by the dealership's management, contact the Honda Power Equipment Customer Relations Office. You can write:

**American Honda Motor Co., Inc.**  
Power Equipment Division  
Customer Relations Office  
4900 Marconi Drive  
Alpharetta, GA 30005-8847

Or telephone: (770) 497-6400 M-F, 8:30 a.m. - 7:00 p.m. ET

When you write or call, please give us this information:

- Model and serial numbers ([page 17](#))
- Name of the dealer who sold the pump to you
- Name and address of the dealer who services your pump
- Date of purchase
- Your name, address, and telephone number
- A detailed description of the problem

### Honda Publications

These publications give you additional information for maintaining and repairing your pump.

**Shop Manual**—This manual covers complete maintenance and overhaul procedures. It is intended to be used by a skilled technician. Available through your Honda dealer or visit [powerequipment.honda.com](http://powerequipment.honda.com) and click on Product Support and then Shop Manuals.

**Parts Catalog**—This manual provides complete illustrated parts lists. It can be viewed for free online by visiting [peparts.honda.com](http://peparts.honda.com). A paper copy of the manual is also available for purchase through your Honda dealer.

### Accessories Catalog

Your authorized Honda power equipment dealer offers a wide selection of accessories to make your pump even more useful. Visit [powerequipment.honda.com](http://powerequipment.honda.com) and click on Accessories and then Pumps to see the entire catalog of accessories.

Especially popular accessories include:

- Suction and discharge hoses
- Strainers
- Couplers and gaskets

### Frequently Asked Questions



The Honda Power Equipment web site provides additional information for users of Honda power equipment. Visit [powerequipment.honda.com](http://powerequipment.honda.com) and click on FAQs or scan the QR code shown.

# DISTRIBUTOR'S LIMITED WARRANTY

## Honda Power Equipment

This warranty is limited to the following Honda Power Equipment products when distributed by American Honda Motor Co., Inc., Power Equipment Division, 4900 Marconi Drive, Alpharetta, Georgia 30005-8847. The following warranty applies to products purchased at retail or placed in rental service on or after January 1, 2010.

PRODUCTS COVERED BY THIS WARRANTY	LENGTH OF WARRANTY (from date of original retail purchase)	
	PRIVATE RESIDENTIAL <sup>(1)</sup>	COMMERCIAL/ RENTAL/INSTITUTIONAL
WDP30X	36 months	36 months

<sup>(1)</sup> Private residential: Used in maintaining owner's primary and/or secondary residence. Any other use, including but not limited to informal "for hire" use, is considered commercial/rental/institutional use.

### To Qualify for This Warranty:

The product must be purchased in the United States, Puerto Rico, or the U.S. Virgin Islands from American Honda or a dealer authorized by American Honda to sell those products. This warranty applies to first retail purchaser and each subsequent owner during the applicable warranty time period, unless noted otherwise.

### What American Honda Will Repair or Replace Under Warranty:

American Honda will repair or replace, at its option, any part that is proven to be defective in material or workmanship under normal use during the applicable warranty time period. Warranty repairs and replacements will be made without charge for parts or labor. Anything replaced under warranty becomes the property of American Honda Motor Co., Inc. All parts replaced under warranty will be considered as part of the original product, and any warranty on those parts will expire coincident with the original product warranty.

### To Obtain Warranty Service:

You must, at your expense, take the Honda Power Equipment product, accessory, replacement part, apparel, or the power equipment on which the accessory or replacement part is installed, and proof of purchase to any Honda Power Equipment dealer in the United States, Puerto Rico, or the U.S. Virgin Islands who is authorized to sell and/or service that product, during the dealer's normal business hours. To locate a dealer near you, visit our web site at [PowerEquipment.Honda.com](http://PowerEquipment.Honda.com) and click on Find a Dealer. If you are unable to obtain warranty service or are dissatisfied with the warranty service you receive, contact the owner of the dealership involved; normally this will resolve the problem. However, if you should require further assistance, write or call the Power Equipment Customer Relations Department of American Honda Motor Co., Inc. See "CUSTOMER SERVICE INFORMATION" on [page 21](#).

### Exclusions:

- Any damage or deterioration resulting from the following:
  - Neglect of the periodic maintenance as specified in this manual
  - Improper repair or maintenance
  - Operating methods other than those indicated in the product owner's manual
  - Increasing engine speed beyond factory specification
  - The use of non-genuine Honda parts, accessories, lubricants, and fluids other than those approved by Honda
  - Exposure of the product to soot and smoke, chemical agents, bird droppings, sea water, sea breeze, salt or other environmental phenomena
  - Collision, fuel contamination or deterioration, neglect, unauthorized alteration, misuse, incorporation or use of unsuitable attachments or parts
  - Normal wear and tear (including, but not limited to, normal fading of painted or plated surfaces, sheet peeling, and other natural deterioration)
- Consumable parts: Honda does not warrant parts deterioration due to normal wear and tear. The following parts are not covered by warranty (unless they are needed as a part of another warranted repair): spark plug, fuel filter, air cleaner element, clutch disc, tire, wheel bearing, recoil starter rope, cable, belt, cutter blade, oil, and grease.
- Cleaning, adjustment, and normal periodic maintenance work (carburetor cleaning, engine oil draining, blade sharpening, belt and cable adjustments).
- Any product that has ever been declared a total loss or sold for salvage by a financial institution or insurer.
- Auger and paddle assemblies of snow throwers, tiller tines of roto-tillers, mower blades and mower deck housings, are specifically not warranted against impact damage, including but not limited to, abrasive damage.

### Disclaimer of Consequential Damage and Limitation of Implied Warranties:

American Honda disclaims any responsibility for loss of time or use of the product, transportation, commercial loss, or any other incidental or consequential damage. Any implied warranties are limited to the duration of this written limited warranty. Some states do not allow limitations on how long an implied warranty lasts and/or do not allow the exclusion or limitation of incidental or consequential damages, so the above exclusions and limitations may not apply to you. This warranty gives you

specific legal rights, and you may also have other rights which vary from state to state.

## Honda Parts, Accessories, and Apparel

This warranty is limited to Honda Power Equipment parts, accessories, and apparel when distributed by American Honda Motor Co., Inc., 4900 Marconi Drive, Alpharetta, Georgia 30005-8847.

PRODUCTS COVERED BY THIS WARRANTY	LENGTH OF WARRANTY (from date of original retail purchase)	
	PRIVATE RESIDENTIAL	COMMERCIAL/ RENTAL/ INSTITUTIONAL
Parts	6 months	3 months
Accessories	12 months	3 months
Apparel	6 months	3 months

### To Qualify for This Warranty:

- The parts, accessories, or apparel must be purchased from American Honda or a dealer authorized by American Honda to sell those products in the United States, Puerto Rico, and the U.S. Virgin Islands. Parts and Accessories must be purchased for installation on original Honda equipment or engines to be eligible for warranty coverage. Installing parts and accessories on non-Honda products or engines voids this warranty.
- You must be the first retail purchaser. This warranty is not transferable to subsequent owners.

### What American Honda Will Repair or Replace Under Warranty:

American Honda will repair or replace, at its option, any Honda Power Equipment parts, accessories, replacement parts, or apparel that are proven to be defective in material or workmanship under normal use during the applicable warranty time period. Anything replaced under warranty becomes the property of American Honda Motor Co., Inc. The warranty on all parts, accessories, and apparel replaced under warranty will expire coincident with the original warranty on the replaced parts, accessories, or apparel.

Parts and accessories installed by a dealer who is authorized by American Honda to sell them will be repaired or replaced under warranty without charge for parts or labor. If installed by anyone else, parts and accessories will be repaired or replaced under warranty without charge for parts, but any labor charges will be the responsibility of the purchaser.

Apparel will be repaired or replaced under warranty without any charge.

### To Obtain Warranty Service:

You must, at your expense, take the Honda Power Equipment part, accessory, apparel or the Honda Power Equipment on which the part or accessory is installed, and proof of purchase to any Honda Power Equipment dealer in the United States, Puerto Rico, or the U.S. Virgin Islands who is authorized to sell that product, during the dealer's normal business hours. To locate a dealer near you, visit our web site at [PowerEquipment.Honda.com](http://PowerEquipment.Honda.com) and click on Find a Dealer. If you are unable to obtain warranty service or are dissatisfied with the warranty service you receive, contact the owner of the dealership involved; normally this will resolve the problem. However, if you should require further assistance, write or call the Power Equipment Customer Relations Department of American Honda Motor Co., Inc. See "CUSTOMER SERVICE INFORMATION" on [page 21](#).

### Exclusions:

This warranty does not extend to parts, accessories, or apparel affected or damaged by collision, normal wear, use in an application for which the product was not designed or any other misuse, neglect, incorporation or use of unsuitable attachments or parts, unauthorized alteration, improper installation, or any causes other than defects in material or workmanship of the product. Installing parts and accessories on non-Honda products or engines voids this warranty.

### Disclaimer of Consequential Damage and Limitation of Implied Warranties:

American Honda disclaims any responsibility for loss of time or use of the product, or the power equipment on which the product is installed, transportation, commercial loss, or any other incidental or consequential damage. Any implied warranties are limited to the duration of this written warranty. Some states do not allow limitations on how long an implied warranty lasts and/or do not allow the exclusion or limitation of incidental or consequential damages, so the above exclusions and limitations may not apply to you.

This warranty gives you specific legal rights, and you may also have other rights which vary from state to state.

PWL50623-W

# EMISSION CONTROL SYSTEM WARRANTY

Your new Honda Power Equipment engine complies with the U.S. EPA and State of California (models certified for sale in California only) emission regulations. American Honda Motor Co., Inc. provides the emission warranty coverage for engines in the United States and its territories. In the remainder of this Emission Control System Warranty, American Honda Motor Co., Inc., will be referred to as Honda.

## YOUR WARRANTY RIGHTS AND OBLIGATIONS:

### CALIFORNIA

The California Air Resources Board and Honda are pleased to explain the emission control system warranty on your 2018 and later Honda Power Equipment engine. In California, new spark-ignited small off-road equipment engines must be designed, built, and equipped to meet the state's stringent anti-smog standards. Specific Honda products that do not meet the California emissions regulations can be identified by a "Not for sale in California" decal.

### OTHER STATES AND U.S. TERRITORIES

In other areas of the United States, your engine must be designed, built, and equipped to meet the U.S. EPA emission standards for spark-ignited engines at or below 19 kilowatts.

### ALL OF THE UNITED STATES

Honda must warrant the emission control system on your power equipment engine for the period of time listed below, provided there has been no abuse, neglect, or improper maintenance of your power equipment engine. Where a warrantable condition exists, Honda will repair your power equipment engine at no cost to you including diagnosis, parts, and labor.

Your emission control system may include such parts as the carburetor or fuel injection system, the ignition system, and catalytic converter. Also included may be hoses, connectors, and other emission-related assemblies (see the adjacent column for additional covered parts).

### OWNER'S WARRANTY RESPONSIBILITY:

As the power equipment engine owner, you are responsible for completing all required maintenance listed in your owner's manual. Honda recommends that you retain all receipts covering maintenance on your power equipment engine, but Honda cannot deny warranty coverage solely for the lack of receipts or for your failure to ensure that all scheduled maintenance has been completed.

As the power equipment engine owner, you should however be aware Honda may deny you warranty coverage if your power equipment engine or a part has failed due to abuse, neglect, improper maintenance, or unapproved modifications.

You are responsible for presenting your power equipment engine to a Honda Power Equipment dealer as soon as a problem exists. The emission related warranty repairs should be completed in a reasonable amount of time, not to exceed 30 days.

If you have any questions regarding your emission warranty rights and responsibilities, you should contact the Honda office in your region:

**American Honda Motor Co., Inc.**  
Power Equipment Customer Relations  
4900 Marconi Drive  
Alpharetta, Georgia 30005-8847  
Telephone: (888) 888-3139  
Email: powerequipmentemissions@ahm.honda.com

### WARRANTY COVERAGE:

Honda power equipment engines sold in the United States are covered by this warranty for a period of two years from the date of delivery to the original retail purchaser or the length of the Honda Distributor's Limited Warranty, whichever is longer. This warranty is transferable to each subsequent purchaser for the duration of the warranty period.

If any emission-related part on your engine is defective, the part will be repaired or replaced by Honda without charge for diagnosis, parts, or labor. All defective parts replaced under this warranty become the property of Honda. Only Honda approved replacement parts may be used in the performance of any warranty repairs and must be provided without charge to the owner. A list of warranted parts is on the adjacent column of this warranty statement. Normal maintenance items, such as spark plugs and filters, that are on the warranted parts list are warranted up to their required replacement interval only.

Honda will also replace other engine components damaged by a failure of any warranted part during the warranty period.

Honda cannot deny coverage under the emission warranty solely for use of non-Honda replacement parts or service performed at a location other than an authorized Honda dealership; however, use of a part that is not functionally identical to the original equipment part in any respect that may in any way affect emissions (including durability) could result in denial of coverage. If such a non-Honda replacement part is used in the repair or maintenance of your engine, and an authorized Honda dealer determines it is defective or causes a failure of a warranted part, your claim for repair of your engine may be denied. If the part in question is not related to the reason your engine requires repair, your claim will not be denied.

### TO OBTAIN WARRANTY SERVICE:

You must, at your own expense, take your Honda Power Equipment engine or the product on which it is installed, along with your sales registration card or other proof of original purchase date, to any Honda Power Equipment dealer who is authorized by Honda to sell and service that Honda product during their normal business hours. Claims for repair or adjustment found to be caused solely by defects in material or workmanship will not be denied because the engine was not properly maintained and used.

If you are unable to obtain emission warranty service or are dissatisfied with the warranty service you received, contact the owner of the dealership involved. Normally this should resolve your problem. However, if you require further assistance, contact the Honda office in your region. Refer to adjacent column for contact information.

### EXCLUSIONS:

Failures other than those resulting from defects in material or workmanship are not covered by this warranty. This warranty does not extend to emission control systems or parts that are affected or damaged by owner abuse, neglect, improper maintenance, misuse, misfueling, improper storage, collision, the incorporation of, or use of, unsuitable attachments, or the unauthorized alteration of any part.

This warranty does not cover replacement of expendable maintenance items made in connection with required maintenance service after the item's first scheduled replacement as listed in the maintenance section of the product owner's manual, such as: spark plugs and filters.

### DISCLAIMER OF CONSEQUENTIAL DAMAGE AND LIMITATION OF IMPLIED WARRANTIES:

American Honda Motor Co., Inc. disclaims any responsibility for incidental or consequential damages such as loss of time or the use of the power equipment, or any commercial loss due to the failure of the equipment; and any implied warranties are limited to the duration of this written warranty. This warranty is applicable only where the California and U.S. EPA emission control system warranty regulation is in effect.

SYSTEMS COVERED BY THIS WARRANTY:	PARTS DESCRIPTION:
Fuel Metering	Carburetor assembly (includes starting enrichment system), Oxygen sensor, Throttle body, Engine temperature sensor, Engine control module, Fuel injector, Fuel regulator, Intake manifold
Evaporative	Fuel tank, Fuel cap, Fuel hoses, Vapor hoses, Carbon canister, Canister mounting brackets, Fuel strainer, Fuel valve, Fuel pump, Fuel hose joint, Canister purge hose joint
Exhaust	Catalyst, Exhaust pipe, Muffler (with catalyst)
Air Induction	Air filter housing, Air filter element*
Ignition	Flywheel comp., Flywheel magneto, Ignition pulse generator, Crankshaft position sensor, Power coil, Ignition coil assembly, Ignition control module, Spark plug cap, Spark plug*
Crankcase Emission Control	Crankcase breather tube, Breather valve assembly, Oil filler cap
Miscellaneous Parts	Tubing, fittings, seals, gaskets, and clamps associated with these listed systems.

Note: This list applies to parts supplied by Honda and does not cover parts supplied by the equipment manufacturer. Please see the original equipment manufacturer's emissions warranty for non-Honda parts.

\* Covered up to the first required replacement only. See the Maintenance Schedule on [page 7](#). PWL50975-S

**HONDA**  
The Power of Dreams