

HONDA
MARINE

Honda HD-4 Color Display User Manual

ENGLISH



Preface

Honda is continuously improving this product, therefore we retain the right to make changes to the product at any time which may not be reflected in this version of the manual. Please contact your nearest Honda dealer if you require any further assistance. It is the owner's sole responsibility to install and use the equipment in a manner that will not cause collisions, personal injury or property damage. The user of this product is solely responsible for observing safe boating practices.

American Honda Motor Co., Inc. disclaims all liability for any use of this product in a way that may cause accidents, damage or that may violate the law.

Governing Language: This statement, any instruction manuals, user guides and other information relating to the product (Documentation) may be translated to, or has been translated from, another language (Translation). In the event of any conflict between any Translation of the Documentation, the English language version of the Documentation will be the official version of the Documentation.

This manual represents the product at the time of printing. Honda and its subsidiaries, branches and affiliates reserve the right to make changes to specifications without notice.

Copyright

All rights reserved — © 2017 American Honda Motor Co., Inc.

Warranty

This warranty is limited to Honda Marine parts, accessories and apparel when distributed by American Honda Motor Co., Inc., 1919 Torrance Blvd., Torrance, California 90501-2746.

Length of Warranty: (from date of original retail purchase):

Non-commercial - 12 months

Commercial - 3 months

Government - 3 months

See the Distributor's Limited Warranty section on page 49 for complete details.

Declaration of Conformity

This equipment is intended for use in international waters as coastal sea area administered by countries of the E.U. and E.E.A.

This gauge complies with the following regulations:

- CE under EMC directive 2004/108/EC
- Level 2 devices of the Radio communications (Electromagnetic Compatibility) standard 2008

The Declaration of conformity is available from www.simrad-yachting.com

Introduction

This manual is a reference guide for operating the Honda HD-4 Color Display.

Important text that requires special attention is emphasized as follows:

- **Note:** Used to draw attention to a comment or important information.

For your safety

Your safety and the safety of others are very important. We have provided important safety messages in this manual. This information alerts you to potential hazards that could hurt you or others. Please read these messages carefully.

Of course, it is not practical or possible to warn you about all the hazards associated with operating this display/gauge. You must use your own good judgment.

Safety Instructions

You will find important safety information in a variety of forms:

Instructions – how to use this display/gauge correctly and safely

Safety Messages – preceded by a safety alert symbol and one of three signal words, DANGER, WARNING, or CAUTION. Each message tells you what the hazard is, what can happen, and what you can do to avoid or reduce injury. These signal words mean:

 **DANGER**

You **WILL** be **KILLED** or **SERIOUSLY HURT** if you don't follow instructions.

 **WARNING**

You **CAN** be **KILLED** or **SERIOUSLY HURT** if you don't follow instructions.

 **CAUTION**

You **CAN** be **HURT** if you don't follow instructions.

Damage Prevention Messages – you will also see other important messages that are preceded by the word NOTICE. This word means:

Notice: Your display/gauge, other property or the environment can be damaged if you don't follow instructions.

Software

This manual is written for: Honda HD-4 Color Display software version 1.0

Please check www.marine.honda.com for details on release version.

Contents

Introduction	3
Software	4
Honda HD-4 Color Display	7
Display and keys	7
Default display pages	8
Page transition	8
Initial setup	9
Select language	9
Time	9
Units	10
Vessel Setup	10
Engine Display Setup	11
Gauge Limits	11
Pop-Ups Setup	12
Operation	13
Menu operation	13
Page menu	13
Settings	13
Backlight	14
Display group	15
Backlight level	15
Night mode	15
Night mode color	15
Pages	16
Static gauge	16
Default fixed data pages	17
Template pages	20
Enabling/disabling a page	21
Replacing/adding a page	21
Configuring page data	22
AutoScroll	23
Trip Log	24
Start/Stop Trip Log	24
Reset Trip Log	24

Refueling	25
Adding fuel for the first time	25
Adding fuel	26
Fuel Used	26
Fuel Used Reset	27
Settings	29
Engine alarms	29
System alarms	30
Enabling an alarm (alarm on/off)	30
Alarms Setting status	31
Alarm limits	31
Alarm indication	32
Acknowledging an alarm	32
Active Alarms	32
Alarm History	33
Engine Alarm settings	34
Alarm Siren	34
Damping	35
System	35
Network	35
Configure	37
Units	37
Decimal places	38
Language	38
Time	38
Simulate	39
Restore defaults	39
Forced factory reset	39
Files	40
Connecting a Micro-USB device	40
Export system settings	41
Import system settings	41
Software	42
About	42
Remote device software upgrade	42
HD-4 Color Display software upgrade	43
Maintenance	45
Specifications	47
Distributor's Limited Warranty	49

1

Honda HD-4 Color Display

The Honda HD-4 Color Display is a NMEA 2000® networked gauge that displays the vessel's engine data and fuel tank information. It can also display instrument data including speed, depth, heading, position, wind and environmental data measured by optional sensors and other equipment connected to the network.

Display and keys

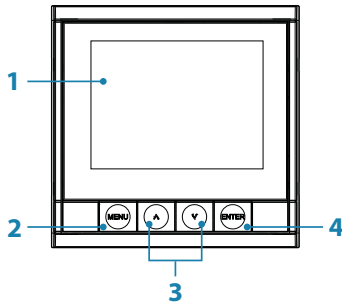

1	DISPLAY		3.5" Color LCD 320 x 240 Resolution
2	MENU key	Short press	Page menu / Return to previous menu
		Long press	Shortcut to Standby and Display setup
3	UP/DOWN key		Scrolls up / down through menu / set values / active page transition
4	ENTER key	Short press	Enter sub menu / Confirm selection
		Long press	Shortcut to Enabled pages

Default display pages

When starting for the first time, the gauge is set with three default pages showing engine and system information. It is possible to add pages via the Pages menu and to change the template pages via the template page sub menu.

The information displayed on fixed data pages cannot be edited by the user. The type of information shown depends on what devices are connected on the network.

- **Note:** Data fields are prioritized automatically. Adding or removing devices from the network may change which data types are displayed on the gauge.

See the Pages section of this manual for more information on page setup and configuration.

Page transition

Use the **UP/DOWN** keys to scroll through the active pages.

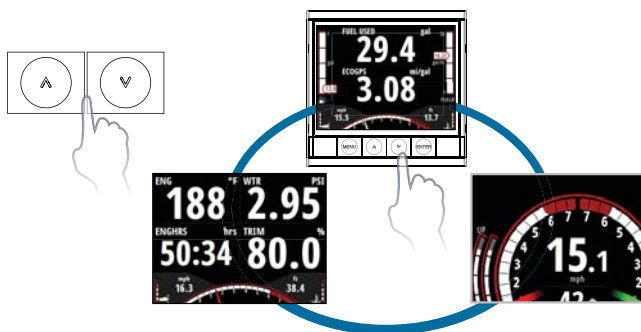

Initial setup

Select the Language, Time, Units, Vessel setup, Engine data display setup, and Gauge limits.

Select Language

Set the preferred language for the gauge. Use the **UP/DOWN** keys to scroll through the languages. Press the **ENTER** key to save the selection.



Time

Set the Local time offset and the preferred time/date formats. Use the **UP/DOWN** keys to scroll through the options. Press the **ENTER** key to select an option to update. Press the **ENTER** key again to exit the option. Select **NEXT** to save the selections.

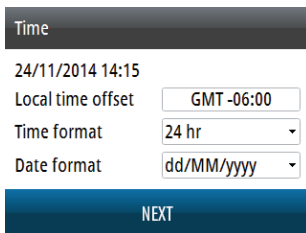

Units

Set the preferred Units. Use the **UP/DOWN** keys to scroll through the options. Press **ENTER** to save the selection.

Units

MPH, Miles, Feet, °F

Knots, Nautical Miles, Feet, °F

Knots, Nautical Miles, Meters, °C

Vessel Setup

Set the number of engines, fuel tanks and total fuel capacity. Use the **UP/DOWN** keys to scroll through the options. Select **OK** to save the selections.

Vessel Setup

Number of Engines 1

Number of Fuel Tanks 1

Total Fuel Capacity (gal) 0180.00

OK Cancel

- **Note:** When entering the Total Fuel Capacity, press the **ENTER** key to advance to the next digit.
- **Note:** These settings are applied to all devices on the network.

Engine Display Setup

Each gauge can display data from one to two engines. Select which engine's data to display on the gauge. Use the **UP/DOWN** keys to scroll through the options. Select **OK** to save the selections.

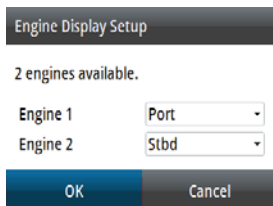

The Motoring data page displays.



Gauge Limits

Set the RPM and vessel fuel rate limits. Press the **MENU** key, and then select the Settings menu. Next, select Installation. Use the **UP/DOWN** keys to scroll through the options.

- **Note:** These limits are a visual guide on the display and do not set alarms.



Select **OK** to save the selections.

The example below shows a Red Line Start setting of 6,000 RPM.



The table below shows the factory rev limit for Honda outboards equipped with NMEA 2000®.

Model	Redline RPM
BF40 ~ BF90	6,000
BF100	6,300
BF115 ~ BF225	6,000
BF250	6,300

Pop-Ups Setup

Set the hreshold and duration that pop-up information will be displayed when the engine trim, trim tabs, or engine transmission is adjusted. Press the **MENU** key, and then select the Settings menu. Next, select Installation. Select **OK** to save the selections.

Pop-ups appear when the gauge sees a change in data that is greater than the set threshold.



➔ **Note:** To disable pop-ups, select OFF.

2

Operation

Menu operation

Page menu

The Page menu options vary from page to page.

Pressing the **MENU** key once on any page will show the available menu options.

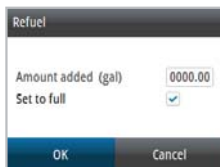
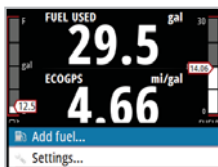

→ **Note:** All page menus have a Settings option. Any other option refers to the current page.

Settings

The Settings menu is where display options, display settings, system settings, source selection and calibration can be accessed.



Example menu structure

1. Press the **MENU** key.
2. Use the **UP/DOWN** keys to navigate through the menu options and the **ENTER** key to make selections.

Example: Access Key beeps dialog via the settings menu.

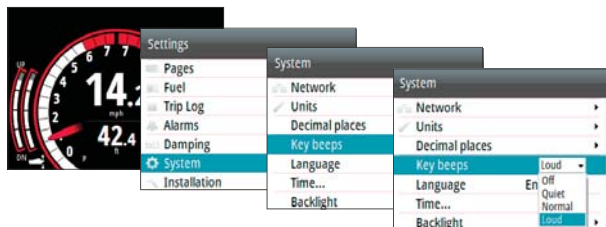

→ **Note:** Pressing the **MENU** key once returns you to the previous menu.

Backlight

There are two methods of adjusting the gauge backlight.

1. Via the menu

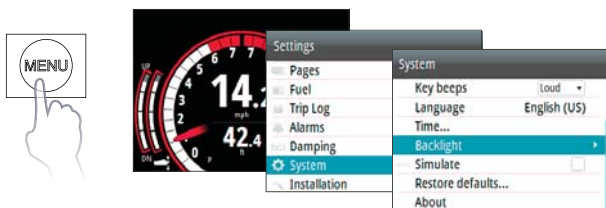

2. Via the Display Setup shortcut

Press and hold the **MENU** key for three seconds to open the Display Setup.

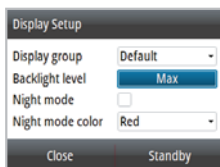

Display group

All units in the selected Display group will mirror each others light settings.

Backlight level

Adjusts the backlight level from Min (10%) to Max (100%) in 10% increments. Use the **UP/DOWN** keys to scroll through the options.

Night mode

Changes the gauge to Night mode color palette. All gauges in the selected Display group will also change to Night Mode.

→ **Note:** Gauge night mode cannot be changed via a Multi-Function Display.

Night mode color

Changes the Night mode color palette.

Pages

Static gauge

Some pages have a static gauge at the bottom of the display showing two pieces of dynamic data, engine trim, temperature and an RPM dial.

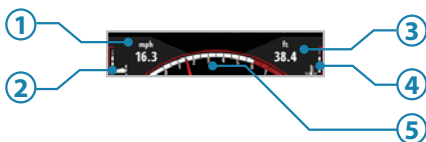

No.	Description	No.	Description
1	Dynamic data field	4	Engine block temp
2	Engine trim	5	RPM dial
3	Dynamic data field		

→ **Note:** Dynamic data fields on the gauge pages and the static gauge automatically populate and the data type shown depends on what devices are on the network.

Static gauge dynamic data field priority order

1. Speed (Speed Over Ground preferred. Requires GPS, paddle wheel, Pitot)
 2. Depth (Requires depth data on the network)
 3. RPM
 4. Fuel economy
 5. Fuel flow
- **Note:** When data from two engines is displayed, only RPM, Engine trim and Engine block temp are shown.

Default fixed data pages



Motoring



No.	Description	No.	Description
1	RPM dial	5	RPM needle
2	Dynamic data field	6	Engine block temp
3	Engine trim	7	RPM limit
4	Dynamic data field		

Motoring dynamic data field priority order

1. Speed (Speed Over Ground preferred. Requires GPS, paddle wheel, Pitot) Depth (Requires depth data on the network)
2. Vessel fuel economy
3. Vessel fuel rate



Fuel economy

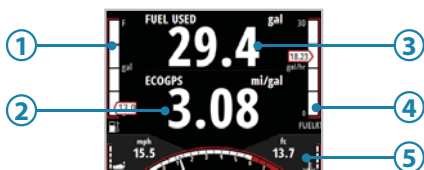

No.	Description	No.	Description
1	Vessel fuel remaining	4	Fuel rate
2	Dynamic data field	5	Static gauge
3	Fuel used		

Fuel dynamic data field priority order

1. Vessel fuel economy (GPS)
 2. Vessel fuel economy (water)
 3. Vessel fuel (rate)
- **Note:** Vessel fuel remaining will only be shown when fuel flow data is available and a fuel storage device such as a Fuel Data Manager is on the network.



Engine



No.	Description	No.	Description
1-4	Dynamic data fields	5	Static gauge

Engine dynamic data field priority order

1. Engine block temp
2. Alternator voltage
3. Engine hours
4. Engine trim

Template pages

Icon	Description	Page
	Single gauge (with RPM)	
	2x2 grid (with RPM)	
	2x1 grid (with RPM)	
	2x2 (bars) grid (with RPM)	
	Quad bars (with RPM)	
	Single gauge (full screen)	
	2x1 grid (full screen)	
	2x2 grid (full screen)	

Enabling/disabling a page

To enable/disable a page you need to first ensure it has been added to the pages list shown in Replacing/adding a page.

1. Press the **ENTER** key on the desired page to open the Enabled/Replace dialog.
2. Press the **ENTER** key to toggle On/Off.

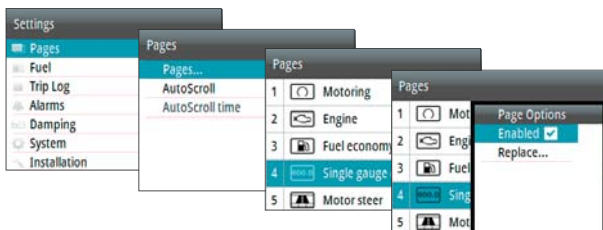

Replacing/adding a page

1. Select the page you want to add/replace.
2. Press the **ENTER** key to open the Enabled/Replace dialog.

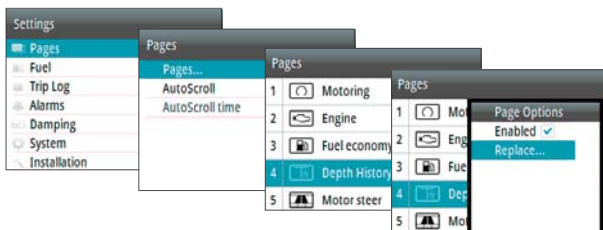

3. Select the desired page from the Replace Page list.

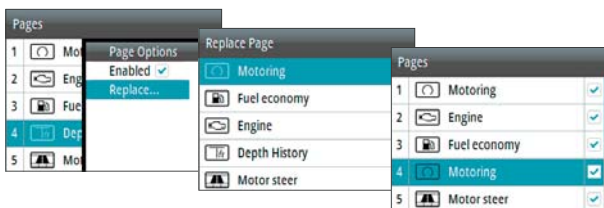

The selected page is shown in the active pages list.

Configuring page data

Once selected, a template page can be configured to show any available system data.

→ **Note:** A template page cannot be edited until it has been selected and enabled as one of the active display pages.

1. Select a page that can be changed, i.e. 2x1 grid.
2. Press the **MENU** key.
3. Select Change data.
4. Select the desired field.
5. Select the desired data type from the menu options.



Once selected, a check mark appears in the check box and the gauge will revert to the page.

The desired data now appears in the selected field. Before saving, you can populate other blank fields by repeating steps 4 and 5.

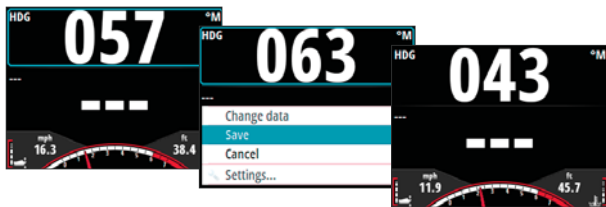

6. Press the **MENU** key.
 7. Select Save.
- **Note:** If a data type is selected but there is no sensor information on the network, the gauge will show as ---.

AutoScroll

Select AutoScroll from the pages menu.

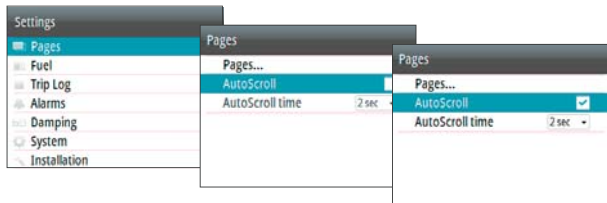

AutoScroll time can be set between 1 and 10 seconds.

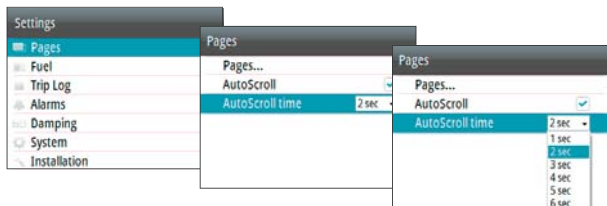

Trip Log

The Trip Log shows trip duration, distance, average speed and max speed from the time the Trip Log was started/reset.

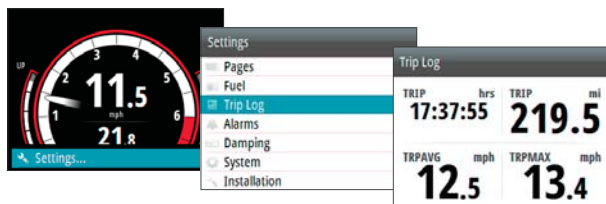

- **Note:** Trip information is calculated using GPS or the paddlewheel if GPS is not present. No Trip Log information is recorded while the Trip Log is stopped.

Start/Stop Trip Log

Starts/Stops the trip log recording.

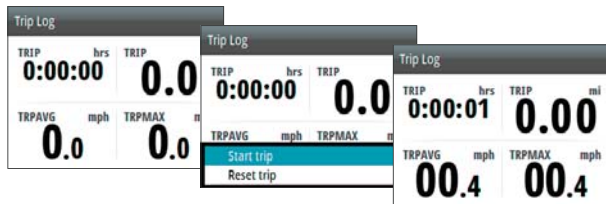

Reset Trip Log

Resets all trip log information to zero.

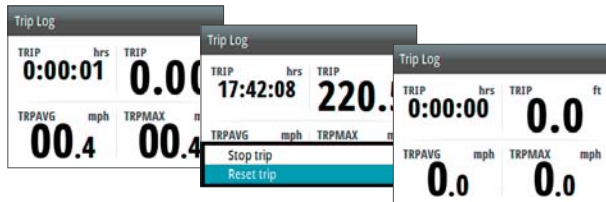

3

Refueling

Adding fuel for the first time

To accurately calculate fuel capacity, fill the tank and select Set to full in the Vessel Refuel dialog. Estimating existing fuel level incorrectly could result in inaccurate fuel remaining and fuel range calculations.

1. Make sure the vessel setup is complete and the number of tanks and total fuel capacity is set to the correct value.
- **Note:** The number of tanks and fuel capacity can be updated using the Vessel Setup page in the installation menu, or by using the initial set-up wizard.

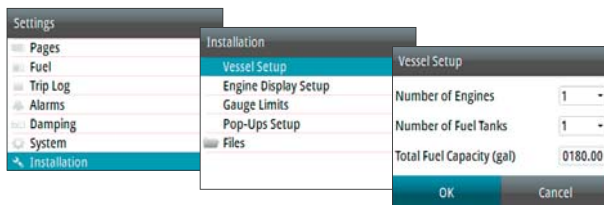

2. Go to the Refuel dialog via the Settings menu.

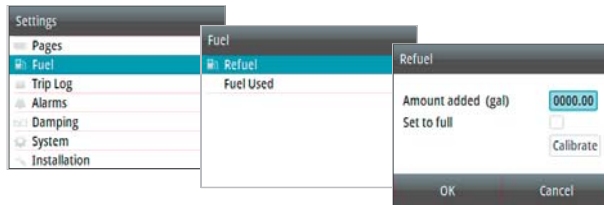

Adding fuel

1. Make sure the vessel setup is complete and the number of tanks and total fuel capacity is set to the correct value.
2. Enter the amount of fuel added to the tank into the Amount added section, or select Set to full when filling the tank to its maximum capacity.

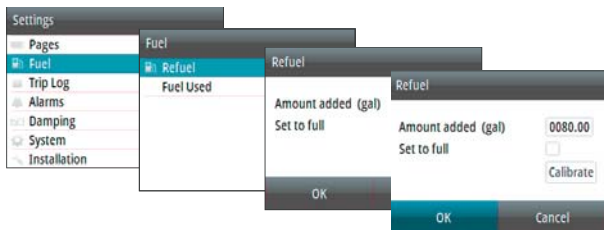

Fuel Used

The Fuel Used dialog shows how much fuel has been used since last fill, from trip reset and seasonal usage (continuous recording).

- **Note:** If more than one engine is on the network, then the Fuel Used data shown is the total for all engines. It also lists the data for each engine.

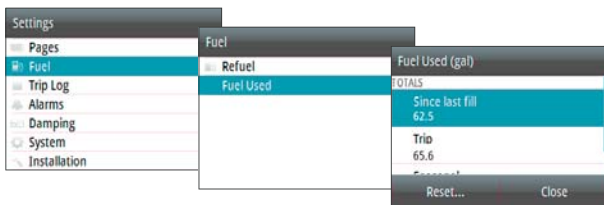

Fuel Used Reset

To access reset to zero options, select Reset at the bottom of the Fuel Used page. Then select the desired reset option from the list.



→ **Note:** You can reset the total for one engine or all engines.

Reset option	Description
None	Returns to Fuel Used page
Trip	Reset Trip fuel used only
Seasonal	Reset Seasonal fuel used only
Both	Reset Trip and Seasonal fuel used

THIS PAGE INTENTIONALLY LEFT BLANK

4





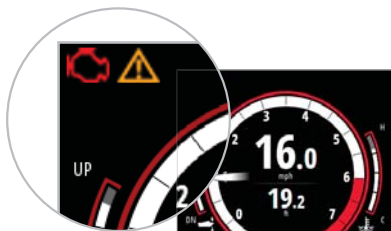

Settings

Engine alarms

For engine-specific alarms, an icon will appear on the display and remain on while that alarm instance is still valid.



- **Note:** The relevant sensor must be on the network for the alarm to be enabled.

Icon	Alarm description
	Low oil pressure
	Engine overheat
	ACG / Charge indicator
	Check engine / General engine faults / Engine or its related system faults
	Warning - Engine malfunction - Check active alarms for available information
	Maintenance Required

System alarms

If a sensor is connected to the network, you can enable alarms by selecting them from the list in the Alarm Settings menu.

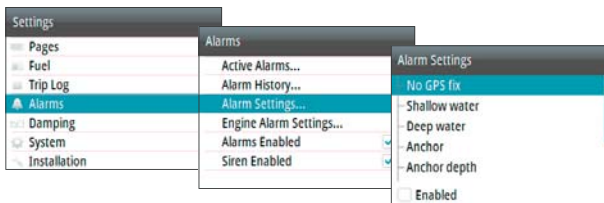

Enabling an alarm (alarm on/off)

Turns an alarm on or off via the Alarm Settings menu.

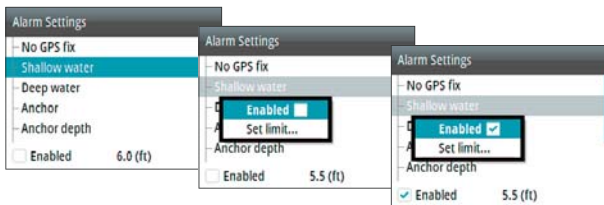

Alarms Setting status

When an alarm option is highlighted, the Enabled dialog at the bottom of the page will show the alarm settings status and alarm limit.

→ **Note:** The relevant sensor must be on the network for the alarm to be enabled.

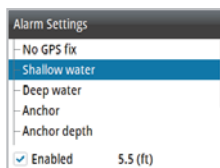

Check box	Description
<input type="checkbox"/> Enabled	Alarm disabled
<input checked="" type="checkbox"/> Enabled	Alarm enabled
<input type="checkbox"/> Enabled	Alarm group (multiple alarms). At least one but not all alarms in the group are enabled
<input type="checkbox"/> Enabled	There is a sub menu with other alarm groups. Select the next level down in the menu to show the alarm status

Alarm limits

Some alarms may feature an adjustable limit. Select the alarm and set the limit in the Alarm Settings menu.

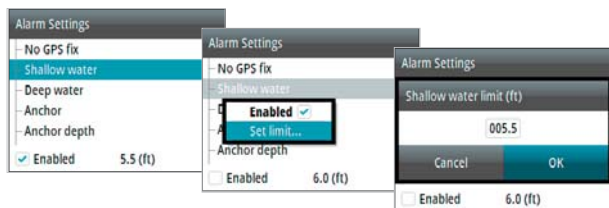

Alarm indication

The alarm is triggered if any settings are exceeded. Alarms are indicated with an alarm text and an audible alarm (optional).

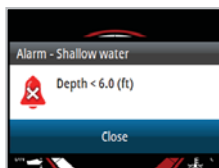

Acknowledging an alarm

An alarm is acknowledged by pressing the **ENTER** key. This removes the alarm notification and silences the alarm. In some cases the alarm icon remains on the gauge until the fault is resolved.

Active Alarms

Lists active alarms on the network. These alarms will be present until the alarm instance is cleared.

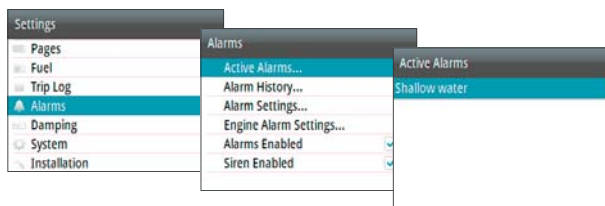

Alarm History

The alarm history can be accessed via the Alarm History menu. This stores alarm messages until they are manually cleared.

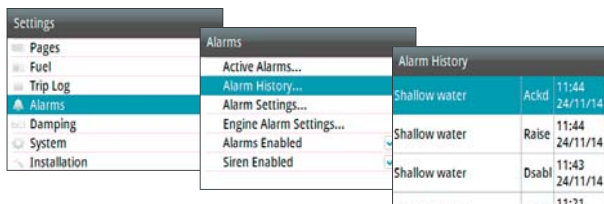

Alarm details

Select an alarm instance to show more details of that specific occurrence and the action taken.

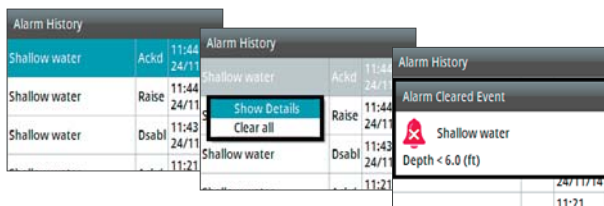

Clear Alarm History

1. Open Alarm History list.
2. Press the **ENTER** key.
3. Select Clear all.



Engine alarm settings

Set all Engine Alarms on or off. If multiple engines are in use, Custom Setting can be used to select which engines alarms are on or off.

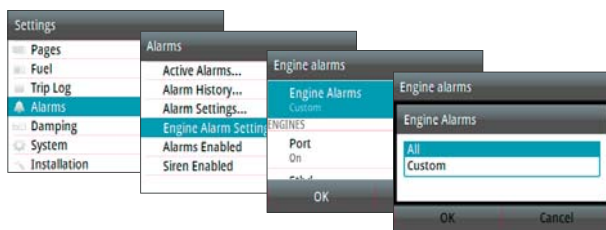

Setting	Description
All	All alarms for all engine are on
Custom	Individually select which engines alarms will be all on or all off

Alarm Siren

When enabled, an audible alarm sounds when an instance is triggered.

→ **Note:** The relevant sensor must be on the network for the alarm to be enabled.

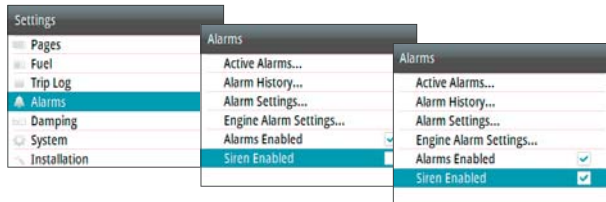

Damping

Damping rate affects how frequently the data is updated; the greater the damping value, the smoother the number change will be, but the change will also be slower.



System

From the System menu, there are several display and system options available.

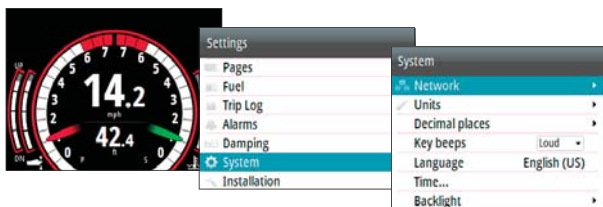

Network

Before the system can be used, the data sources need to be configured.

Sources

A data source can be a sensor or a device connected to the network that provides information and commands to other networked devices. The data sources are normally configured the first time the system is turned on. It should only be necessary to update this data if a new source is added, data is missing or removed, a source has been enabled/disabled, a sensor replaced or after a network reset.

Auto Select

The Auto Select option looks for all sources connected to the network. If more than one source is available for each item, the gauge automatically selects from the internal device priority list.

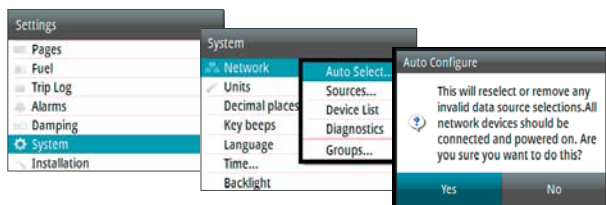

Device list

Shows a list of all devices connected to the network.

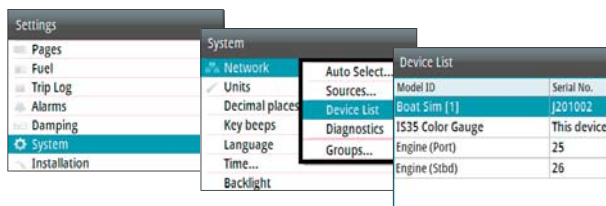

Selecting a device in this list brings up additional details and actions.

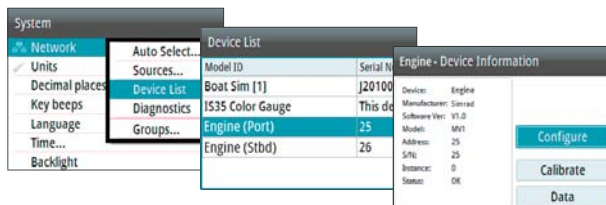

Configure

All units come pre-configured, but they can be modified once connected to the network. The example below shows how to configure the engine location.

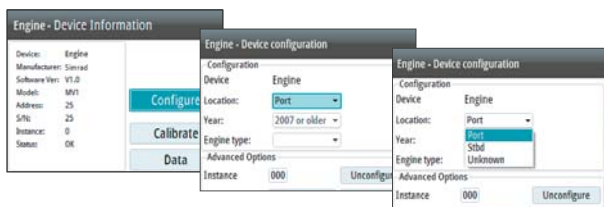

- **Note:** Configuring the engine location correctly is important when more than one engine is on the network.

Some devices show additional options specific to the device. For example, the Calibrate option allows easy setup of a device. Calibration options vary depending on the device.

Diagnostics

NMEA 2000® Bus diagnostic data on the network.

Units

Set the unit of measurement for how you want the data to be displayed.

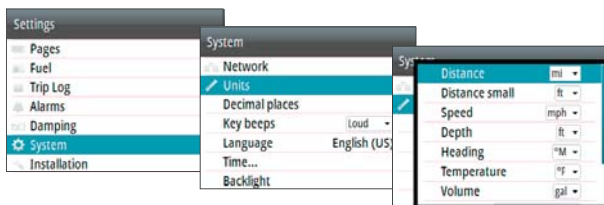

Decimal places

Set the number of decimal places for the vessel speed and sea temperature display.

Language

Set the preferred language for the gauge.

- **Note:** This is not a network function. You need to change all gauges separately.



- **Note:** The unit automatically restarts once the language is selected.

Time

Set the preferred time/date format and the Local time offset.

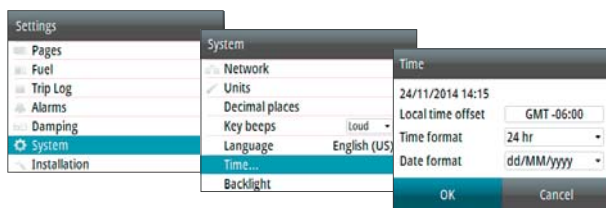

Simulate

Sends simulated data to the gauge.

- **Note:** All other gauges on the network continue to display the current vessel data and do not change to simulate mode. A Simulating warning box flashes on and off at the top of the display.

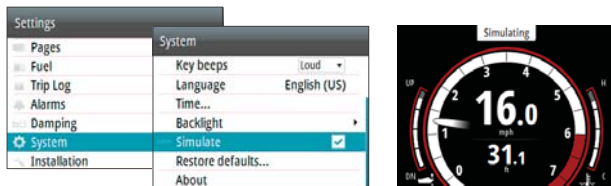

- **Note:** To exit the simulate mode, disable the Simulate option in the System menu.

Restore defaults

Restore all system settings of the gauge to factory defaults.

- **Note:** This is not a network function. This only resets and deletes history on the individual gauges selected.

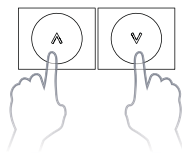
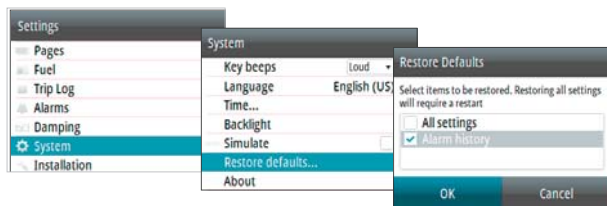

Forced factory reset

If the gauge does not respond to the normal restore procedures, press and hold the **UP/DOWN** keys while powering the unit on. A beep signifies the reset has been completed.

Files

Access an attached USB device, import/export system settings, template page, and vessel setup. Upgrade the software on the engine gauge and remote devices.

- **Note:** Each gauge on the network needs to be upgraded individually.

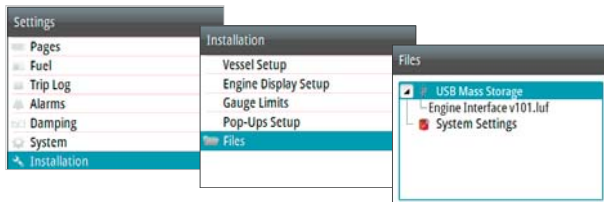

Connecting a Micro-USB device

1. Remove the USB cover from the rear of the gauge.
2. Insert a USB Micro USB adaptor and mass storage device.

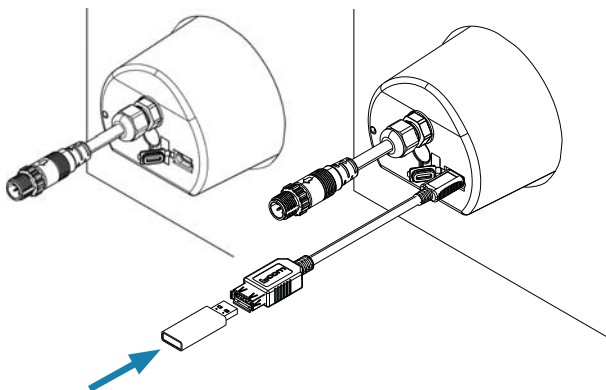

Export system settings

1. Insert a USB Micro USB adaptor and mass storage device.
2. Go to the Files menu.
3. Select System Settings.
4. Press the **ENTER** key to export system settings to the USB mass storage device.

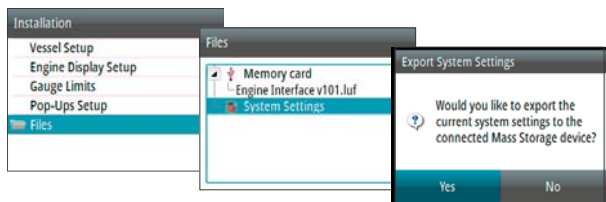

Import system settings

1. Insert a USB Micro USB adaptor and mass storage device.
 2. Go to the Files menu.
 3. Select the Settings.iset file from the USB memory, the details dialog will appear. Press the **ENTER** key to confirm import.
- **Note:** Importing system settings overwrites all existing system settings and restarts the gauge!

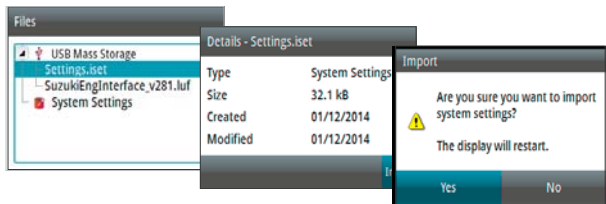

Software

About

Shows the device information and current software version installed on the gauge. Press the **MENU** key to exit.

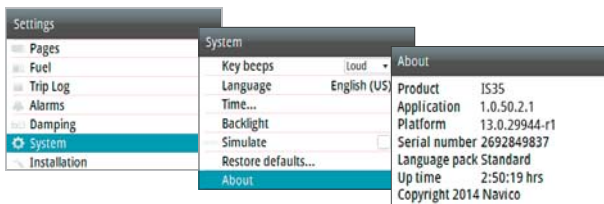

To show the current version of software on a remote device, go to the Device List and select the relevant device.

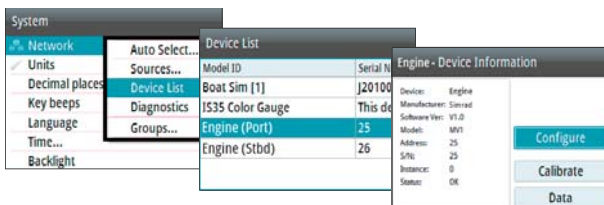

Remote device software upgrade

Update the software for the NMEA 2000® sensors.

1. Verify the software version via the Device List.
2. Save the update file to a USB mass storage device.
3. Connect the portable storage device to the micro USB slot.
4. Select the update file from the USB memory.
5. When the details dialog appears, press the **ENTER** key.
6. Press the **ENTER** key again to confirm upgrade.

7. The upgrade progress dialog will appear. Press the **ENTER** key when the upgrade is complete.

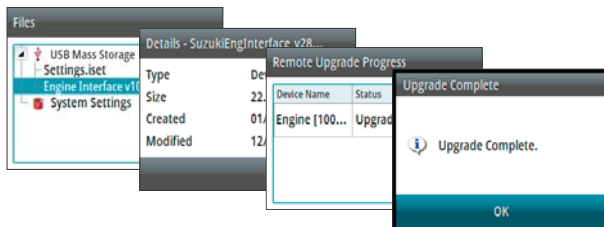

HD-4 Color Display software upgrade

1. Verify the software version via the About dialog.
2. Save the latest .upd file to a USB mass storage device.
3. Ensure the gauge power is off.
4. Insert the USB mass storage device via the USB adaptor.
5. Turn the power on. The gauge will automatically begin the upgrade procedure.
6. A message will appear on the gauge once the update is complete.
7. Remove the USB device and replace the USB cover.

Notice: Do not remove the USB storage device until prompted to do so once the update is complete. Removing the USB storage device before the update is complete may cause the gauge to become unresponsive or require repair!

THIS PAGE INTENTIONALLY LEFT BLANK

5

Maintenance

If the gauge needs to be cleaned, use fresh water and a mild soap solution (not a detergent). Avoid using chemical cleaners containing hydrocarbons, such as diesel, gasoline etc.

Checking the keys

Make sure that none of the keys are stuck in the down position.

Checking the connector

The connector should be checked by visual inspection only. Ensure that the cable is connected correctly and the USB port cover is in place.

THIS PAGE INTENTIONALLY LEFT BLANK

6

Specifications

Mass (weight)	0.28 kg (0.60 lbs)
Power consumption	130 mA at 13.5V NMEA 2000® Load Equivalency Number (LEN): 3
Network load	Maximum 10 gauges
Color	Black
Display	
Size	3.5" (Diagonal) 4:3 Aspect ratio
Type	Transmissive TFT-LCD White LED back-light
Resolution	320 x 240 pixels
Illumination	White (day mode) Red/Green/Blue (night mode)
Environmental Protection	IPX7
Safe distance to compass	0.3 m (1.0 ft)
Temperature	
Operating	-15 to +55° C (+5 to +131° F)
Storage	-25 to +65° C (-13 to +149° F)

THIS PAGE INTENTIONALLY LEFT BLANK

7

Distributor's Limited Warranty

Accessories and Replacement Parts

This warranty is limited to Honda Marine parts, accessories and apparel when distributed by American Honda Motor Co., Inc., 1919 Torrance Blvd., Torrance, California 90501-2746.

Length of Warranty: (from date of original retail purchase):

NON-COMMERCIAL - 12 months

COMMERCIAL/RENTAL - 3 months

STATE/LOCAL/FEDERAL

GOVERNMENT - 3 months

To Qualify for This Warranty:

1. The accessories or replacement parts must be purchased from American Honda or a dealer, distributor, or distributor's dealer authorized by American Honda to sell those products in the United States, Puerto Rico, and the U.S. Virgin Islands. Parts and Accessories must be purchased for installation on original Honda equipment or engines to be eligible for warranty coverage. Installing Parts and Accessories on non-Honda products or engines voids this warranty.
2. You must be the first retail purchaser. This warranty is not transferable to subsequent owners.

What American Honda Will Repair or Replace Under Warranty:

American Honda will repair or replace, at its option, any marine product accessories or replacement parts that are proven to be defective in material or workmanship under normal use during the applicable warranty time period. Anything replaced under warranty becomes the property of American Honda Motor Co., Inc.

All parts replaced under warranty will be considered as part of the original product and any warranty on those parts will expire coincidentally with the original product warranty.

Accessories and replacement parts, installed by a dealer who is authorized by American Honda to sell them, will be repaired or replaced under warranty without charge for parts or labor.

If installed by anyone else, accessories and replacement parts will be repaired or replaced under warranty without charge for parts, but any labor charges will be the responsibility of the purchaser.

To Obtain Warranty Service:

You must, at your expense, take the Honda Outboard Motor product accessory or replacement part or the outboard motor or boat on which the accessory or replacement part is installed, and proof of purchase to any Honda Marine authorized service facility or dealer in the United States, Puerto Rico, or the U.S. Virgin Islands, during normal business hours.

Exclusions:

This warranty does not extend to accessories or parts affected or damaged by collision, normal wear, use in an application for which the product was not designed or any other misuse, neglect, incorporation or use of unsuitable attachments or parts, unauthorized alteration, improper installation, or any causes other than defects in material or workmanship of the product. Installing parts and accessories on non-Honda products or engines voids this warranty.

Disclaimer of consequential damage and limitation of implied warranties:

American Honda disclaims any responsibility for loss of time or use of the outboard motor, or the boat on which the product is installed, transportation, commercial loss, or any other incidental or consequential damage. Any implied warranties are limited to the duration of this written warranty. Some states do not allow limitations on how long an implied warranty lasts and/or do not allow the exclusion or limitation of incidental or consequential damages, so the above exclusions and limitations may not apply to you.

This warranty gives you specific legal rights, and you may also have other rights, which vary from state to state.

NOTES

