

**HONDA**  
**MARINE**

**BF8D·BF9.9D·BFP8D·BFP9.9D  
BF15D·BF20D·BFP15D·BFP20D  
Owner's Manual**

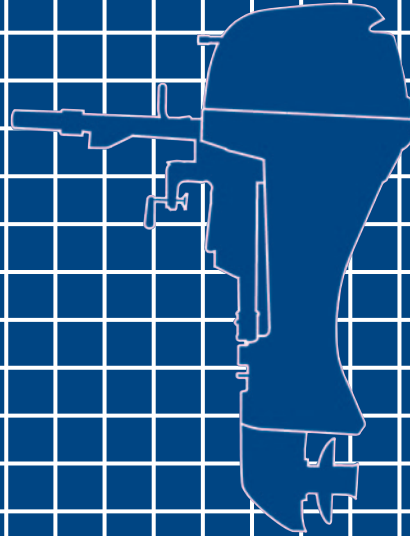



## **WARNING:**



The engine exhaust from this product contains chemicals known to the State of California to cause cancer, birth defects, or other reproductive harm.

Keep this owner's manual handy, so you can refer to it at any time. This owner's manual is considered a permanent part of the outboard motor and should remain with the outboard motor if resold.

The information and specifications included in this publication were in effect at the time of approval for printing. Honda Motor Co., Ltd. reserves the right, however, to discontinue or change specifications or design at any time without notice and without incurring any obligation whatever. No part of this publication may be reproduced without written permission.

# INTRODUCTION

Congratulations on your selection of a Honda outboard motor. We are certain you will be pleased with your purchase of one of the finest outboard motors on the market.

We want to help you get the best results from your new outboard motor and to operate it safely. This manual contains information on how to do that; please read it carefully.

As you read this manual you will find information preceded by a

**NOTICE** symbol. That information is intended to help you avoid damage to your outboard motor, other property, or the environment.

We suggest you read the warranty policy to fully understand its coverage and your responsibilities of ownership.

When your outboard motor needs scheduled maintenance, keep in mind that your Honda marine dealer is specially trained in servicing Honda outboard motors. Your Honda marine dealer is dedicated to your satisfaction and will be pleased to answer your questions and concerns.

Best Wishes,  
Honda Motor Co., Ltd.

# INTRODUCTION

---

## A FEW WORDS ABOUT SAFETY

Your safety and the safety of others are very important. And using this outboard motor safely is an important responsibility.

To help you make informed decisions about safety, we have provided operating procedures and other information on labels and in this manual. This information alerts you to potential hazards that could hurt you or others.

Of course, it is not practical or possible to warn you about all the hazards associated with operating or maintaining an outboard motor. You must use your own good judgment.

You will find important safety information in a variety of forms, including:

- **Safety Labels** — on the outboard motor.
- **Safety Messages** — preceded by a safety alert symbol  and one of three signal words, DANGER, WARNING, or CAUTION.

These signal words mean:

 You **WILL** be **KILLED** or **SERIOUSLY HURT** if you don't follow instructions.

 You **CAN** be **KILLED** or **SERIOUSLY HURT** if you don't follow instructions.

 You **CAN** be **HURT** if you don't follow instructions.

- **Safety Headings** — such as *IMPORTANT SAFETY INFORMATION*.
- **Safety Section** — such as *OUTBOARD MOTOR SAFETY*.
- **Instructions** — how to use this outboard motor correctly and safely.

This entire book is filled with important safety information — please read it carefully.

# CONTENTS

OUTBOARD MOTOR SAFETY.....	7	Manual Relief Valve (T type).....	26
IMPORTANT SAFETY INFORMATION.....	7	Tilt Lock Lever (G and T type).....	27
SAFETY LABEL LOCATIONS.....	9	Common Controls	
CONTROLS AND FEATURES .....	10	Engine Cover Latch .....	27
CONTROL AND FEATURE		Transom Angle Adjusting Rod.....	27
IDENTIFICATION CODES .....	10	Tilt Lever (manual tilt type).....	28
COMPONENT AND CONTROL LOCATIONS.....	14	INSTRUMENTS.....	29
CONTROLS.....	19	Fuel Gauge .....	29
H Type (tiller handle)		Tachometer [optional equipment (R type)] .....	29
Engine Stop Switch and Switch Clip.....	19	INDICATORS.....	30
Choke Knob (H type manual choke) .....	19	Oil Pressure Indicator (R type) (H type).....	30
Throttle Grip.....	20	Overheat Indicator.....	30
Throttle Friction Adjuster .....	20	R type .....	30
Gearshift Lever .....	20	H type.....	31
Recoil Starter Grip .....	21	Cooling System Indicator .....	31
Electric Starter Button		OTHER FEATURES .....	32
(types equipped with electric starter).....	21	Overrev Limiter.....	32
Steering Friction Lever .....	21	Automatic Choke	
Power Tilt Switch (T type).....	22	(types equipped with electric starter).....	32
Tilt Lever (G type) .....	22	Anodes.....	32
R Type (remote control)		Portable Fuel Tank .....	32
Ignition Switch.....	23	Fuel Filler Cap Vent Knob.....	33
Emergency Stop Switch and Switch Clip.....	23	Fuel Priming Bulb.....	33
Fast Idle Lever.....	24		
Gearshift/Throttle Control Lever.....	25		
Power Tilt Switch (T type).....	26		

# CONTENTS

---

INSTALLATION.....	34	PORTABLE FUEL TANK.....	44
POWER REQUIREMENTS.....	34	FUEL HOSE CONNECTIONS.....	44
BOAT TRANSOM REQUIREMENTS.....	34	FUEL PRIMING.....	45
INSTALLATION POSITION.....	34	STARTING THE ENGINE.....	45
ATTACHMENT.....	35	H Type (tiller handle).....	45
TRANSOM ANGLE ADJUSTMENT.....	36	R Type (remote control).....	48
BATTERY CONNECTIONS.....	36	EMERGENCY STARTING.....	50
BEFORE OPERATION.....	39	STOPPING THE ENGINE.....	53
ARE YOU READY TO GET UNDER WAY ? .....	39	Emergency Engine Stopping.....	53
IS YOUR OUTBOARD MOTOR		Normal Engine Stopping.....	53
READY TO GO ? .....	39	GEARSHIFT AND	
OPERATION.....	41	THROTTLE OPERATION.....	55
SAFE OPERATING PRECAUTIONS.....	41	H Type (tiller handle).....	55
BREAK-IN PROCEDURE.....	41	R Type (remote control).....	56
TRANSOM ANGLE ADJUSTMENT.....	42	STEERING.....	57
		H Type (tiller handle).....	57
		R Type (remote control).....	57
		CRUISING.....	58
		SHALLOW WATER OPERATION.....	60
		MOORING, BEACHING, LAUNCHING.....	63

# CONTENTS

SERVICING YOUR OUTBOARD MOTOR.....	65	STORAGE .....	87
THE IMPORTANCE OF MAINTENANCE.....	65	STORAGE PREPARATION .....	87
MAINTENANCE SAFETY .....	66	Cleaning and Flushing .....	87
TOOL KIT AND EMERGENCY STARTER		Fuel.....	88
ROPE.....	67	Engine Oil .....	91
MAINTENANCE SCHEDULE .....	68	STORAGE PRECAUTIONS .....	91
MANUAL RELIEF VALVE (T type).....	70	REMOVAL FROM STORAGE.....	92
ENGINE COVER REMOVAL AND			
INSTALLATION.....	70	TRANSPORTING .....	93
Engine Oil Level Check.....	71	WITH OUTBOARD MOTOR INSTALLED	
Engine Oil Change.....	72	ON BOAT .....	93
Oil Filter Change.....	73	WITH OUTBOARD MOTOR REMOVED	
Engine Oil Recommendations .....	74	FROM BOAT .....	93
Gear Oil Level Check.....	74		
Gear Oil Change.....	75	TAKING CARE OF UNEXPECTED PROBLEMS .....	94
Lubrication Points .....	77	ELECTRIC STARTER WILL NOT OPERATE.....	94
Spark Plug Service .....	78	ENGINE WILL NOT START.....	95
REFUELING.....	79	HARD STARTING OR STALLS AFTER	
FUEL RECOMMENDATIONS.....	80	STARTING.....	97
Fuel Filter Inspection and Replacement .....	81	ENGINE OVERHEATS .....	98
Portable Fuel Tank and Filter Cleaning .....	83	BATTERY WILL NOT CHARGE AND	
Recoil Starter Rope Inspection .....	84	ELECTRIC STARTER WILL NOT OPERATE..	99
Anode Replacement .....	84	Fuse Replacement .....	99
Choke Knob Friction.....	85	OIL PRESSURE INDICATOR LIGHT GOES OFF	
Propeller Replacement .....	86	AND ENGINE SPEED IS LIMITED .....	100
		OVERHEAT AND ENGINE SPEED IS LIMITED .....	101
		SUBMERGED MOTOR .....	103

# CONTENTS

---

TECHNICAL AND CONSUMER INFORMATION.....	105
TECHNICAL INFORMATION.....	105
Serial Number locations.....	105
Carburetor Modification for High Altitude Operation.....	106
Oxygenated Fuels.....	107
Emission Control System Information .....	108
Star Label .....	110
Specifications .....	112
CONSUMER INFORMATION .....	120
Honda Publications .....	120
Customer Service Information.....	120
Distributor's Limited Warranty — 2006 .....	123
Emission Control System Warranty .....	127
INDEX.....	131
WIRING DIAGRAMS .....	Inside back cover

This Owner's Manual uses the following Type names when describing an operation unique to a particular Type:

Tiller handle type:	H type
Remote control type:	R type
Gas assist type:	G type
Power tilt type:	T type

Check the type of your outboard motor and read this Owner's Manual thoroughly before operation. Text with no Type indication refers to information/procedures common to all Types.



# OUTBOARD MOTOR SAFETY

## IMPORTANT SAFETY INFORMATION

The Honda BF8D/BFP8D/BF9.9D/BFP9.9D/BF15D/BFP15D/BF20D and BFP20D outboard motors are designed for use with boats that have a suitable manufacturer's power recommendation. Other uses can result in injury to the operator or damage to the outboard motor and other property.

Most accidents can be prevented if you follow all instructions in this manual and on the outboard motor. The most common hazards are discussed below, along with the best way to protect yourself and others.

## Operator Responsibility

- It is the operator's responsibility to provide the necessary safeguards to protect people and property. Know how to stop the engine quickly in case of emergency. Understand the use of all controls.
- Stop the engine immediately if anyone falls overboard, and do not run the engine while the boat is near anyone in the water.
- Always stop the engine if you must leave the controls for any reason.
- Attach the emergency stop switch lanyard securely to the operator.
- Always wear a PFD (Personal Flotation Device) while on the boat.
- Familiarize yourself with all laws and regulations relating to boating and the use of outboard motors.
- Be sure that anyone who operates the outboard motor receives proper instruction.
- Be sure the outboard motor is properly mounted on the boat.
- Do not remove the engine cover while the engine is running.

# OUTBOARD MOTOR SAFETY

---

## Refuel With Care

- Gasoline is extremely flammable, and gasoline vapor can explode. Refuel outdoors, in a well-ventilated area, with the engine stopped. Never smoke near gasoline, and keep other flames and sparks away.
- Remove any portable fuel tank from the boat for refueling. Keep the portable fuel tank away from the battery or other potential spark sources.
- Refuel carefully to avoid spilling fuel. Avoid overfilling the fuel tank.
- After refueling, tighten the filler cap securely. If any fuel is spilled, make sure the area is dry before starting the engine.

## Carbon Monoxide Hazard

Exhaust gas contains poisonous carbon monoxide. Avoid inhalation of exhaust gas. Never run the engine in a closed garage or confined area.

## SAFETY LABEL LOCATIONS

**WARNING**  
**PRESSURIZED GAS**  
**DO NOT PUNCTURE**  
**OR INCINERATE.**

(G type)

**READ OWNER'S MANUAL CAREFULLY BEFORE OPERATION**

**WARNING**

- PLACE TRANSMISSION IN NEUTRAL BEFORE STARTING.
- DO NOT OPERATE WITH ENGINE COVER REMOVED.
- BE SURE THE ANTIVENTILATION PLATE IS BELOW THE WATER LINE.
- DO NOT SHIFT TO REVERSE SUDDENLY AT HIGH SPEED.
- CHECK OIL LEVEL BEFORE STARTING.
- RUSH THE SYSTEM THOROUGHLY WITH FRESH WATER AFTER EACH USE IN SALT WATER.
- EMERGENCY STARTING INSTRUCTIONS ARE ON TOP OF ENGINE.

**EMERGENCY STARTING**

1. PRESS SELECTOR SWITCH TO NEUTRAL.
2. HOLD GAS LEVER FLOWERSIDE.
3. KEEP HEADS CLEAR OF ENGINE WHILE PULLING ROPE.

**WARNING**

MOVING PARTS CAN INJURE YOU.  
 ALWAYS CLOSE COVER AFTER STARTING ENGINE.

**READ OWNER'S MANUAL**

**GASOLINE FLAMMABLE DANGER**

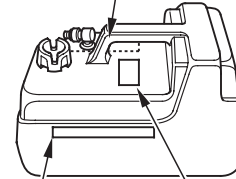

**DANGER**

HARMFUL OR FATAL IF SWALLOWED.  
 KEEP OUT OF REACH OF CHILDREN.  
 IF SWALLOWED DO NOT INDUCE  
 VOMITING. CALL A PHYSICIAN  
 IMMEDIATELY.

**GASOLINE FLAMMABLE DANGER**

The labels shown here contain important safety information. Please read them carefully. These labels are considered permanent parts of your outboard motor. If a label comes off or becomes hard to read, contact an authorized Honda marine dealer for a replacement.

# CONTROLS AND FEATURES

## CONTROL AND FEATURE IDENTIFICATION CODES

Model	BF8D					BFP8D				
	SHA	LHA	SHSA	LHSA	LRA	LHA	XHA	XHSA	LHTA	LRTA
Shaft Length	S	L	S	L	L	L	X	X	L	L
Tiller Handle	H	H	H	H		H	H	H	H	
Remote Control					R					R
Electric Starter			S	S	S			S	S	S
Power Tilt									T	T
Power Thrust Propeller						P	P	P	P	P
Battery Charging DC Receptacle	●	●				●	●			
Tachometer					*					*

Refer to this chart for an explanation of the Type Codes used in this manual to identify control and feature applications.

BF8D/BFP8D are provided with the following types according to the shaft length, control system, tilt system, and start system.

- Shaft Length  
S: Short Shaft  
L: Long Shaft  
X: Extra Long Shaft
- Control System  
H: Tiller Handle Control  
R: Remote Control

- Tilt system  
T : Power Tilt (with hydraulic assist function)

- \* : Optional Equipment
- : Standard Equipment

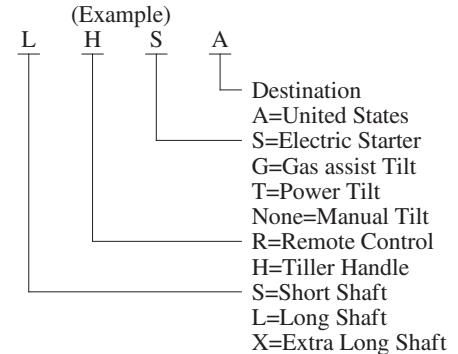

# CONTROLS AND FEATURES

Model	BF9.9D						BFP9.9D							
	SHA	LHA	SHSA	LHSA	LRA	SRTA	LHA	XHA	XHSA	LRA	LHTA	XHTA	LRTA	XRTA
Shaft Length	S	L	S	L	L	S	L	X	X	L	L	X	L	X
Tiller Handle	H	H	H	H			H	H	H		H	H		
Remote Control					R	R				R			R	R
Electric Starter			S	S	S	S			S	S	S	S	S	S
Power Tilt						T					T	T	T	T
Power Thrust Propeller							P	P	P	P	P	P	P	P
Battery Charging DC Receptacle	●	●					●	●						
Tachometer					*	*				*			*	*

Refer to this chart for an explanation of the Type Codes used in this manual to identify control and feature applications.

BF9.9D/BFP9.9D are provided with the following types according to the shaft length, control system, tilt system, and start system.

- Shaft Length
  - S: Short Shaft
  - L: Long Shaft
  - X: Extra Long Shaft
- Control System
  - H: Tiller Handle Control
  - R: Remote Control

- Tilt system
  - T : Power Tilt (with hydraulic assist function)

- \* : Optional Equipment
- : Standard Equipment

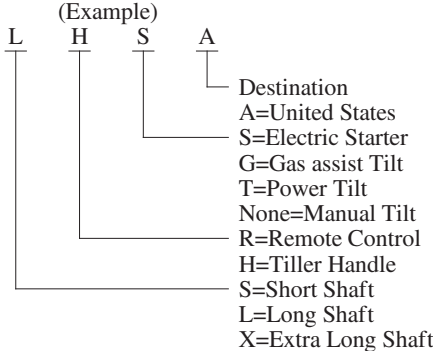

# CONTROLS AND FEATURES

Model	BF15D													BFP15D		
	SHA	LHA	XHA	SHSA	LHSA	LRA	SHGA	LHGA	XHGA	SHTA	LHTA	SRTA	LRTA	XHTA	LRTA	XRTA
Shaft Length	S	L	X	S	L	L	S	L	X	L	L	S	L	X	L	X
Tiller Handle	H	H	H	H	H		H	H	H	H	H			H		
Remote Control						R						R	R		R	R
Electric Starter				S	S	S	S	S	S	S	S	S	S	S	S	S
Gas Assist Tilt							G	G	G							
Power Tilt										T	T	T	T	T	T	T
Power Thrust Propeller														P	P	P
Battery Charging DC Receptacle	●	●	●													
Tachometer						*						*	*		*	*

Refer to this chart for an explanation of the Type Codes used in this manual to identify control and feature applications.

BF15D/BFP15D are provided with the following types according to the shaft length, control system, tilt system, and start system.

- Shaft Length  
S: Short Shaft  
L: Long Shaft  
X: Extra Long Shaft
- Control System  
H: Tiller Handle Control  
R: Remote Control

- Tilt system  
G : Gas assist Tilt (with gas damper assist function)  
T : Power Tilt (with hydraulic assist function)

- \* : Optional Equipment
- : Standard Equipment

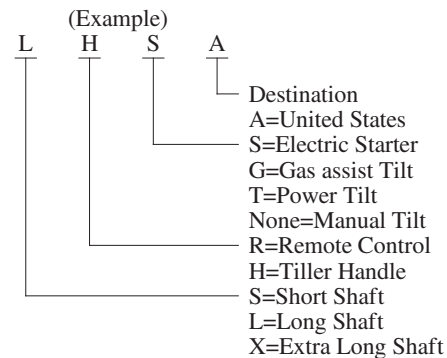

# CONTROLS AND FEATURES

Type	BF20D															BFP20D
	SHA	LHA	SHSA	LHSA	XHSA	SRA	LRA	SHGA	LHGA	XHGA	SHTA	LHTA	XHTA	SRTA	LRTA	LRTA
Shaft Length	S	L	S	L	X	S	L	S	L	X	S	L	X	S	L	L
Tiller Handle	H	H	H	H	H			H	H	H	H	H	H			
Remote Control						R	R							R	R	R
Electric Starter			S	S	S	S	S	S	S	S	S	S	S	S	S	S
Gas Assist Tilt								G	G	G						
Power Tilt											T	T	T	T	T	T
Power Thrust Propeller																P
Battery Charging DC Receptacle	●	●														
Tachometer						*	*							*	*	*

Refer to this chart for an explanation of the Type Codes used in this manual to identify control and feature applications.

BF20D/BFP20D are provided with the following types according to the shaft length, control system, tilt system, and start system.

- Shaft Length
  - S: Short Shaft
  - L: Long Shaft
  - X: Extra Long Shaft
- Control System
  - H: Tiller Handle Control
  - R: Remote Control

- Tilt system
  - G: Gas assist Tilt (with gas damper assist function)
  - T: Power Tilt (with hydraulic assist function)

- \* : Optional Equipment
- : Standard Equipment

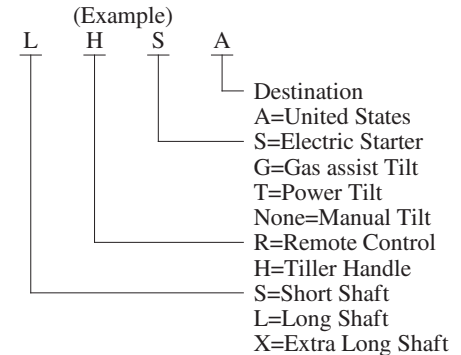

# CONTROLS AND FEATURES

---

## COMPONENT AND CONTROL LOCATIONS

### H Type (tiller handle)

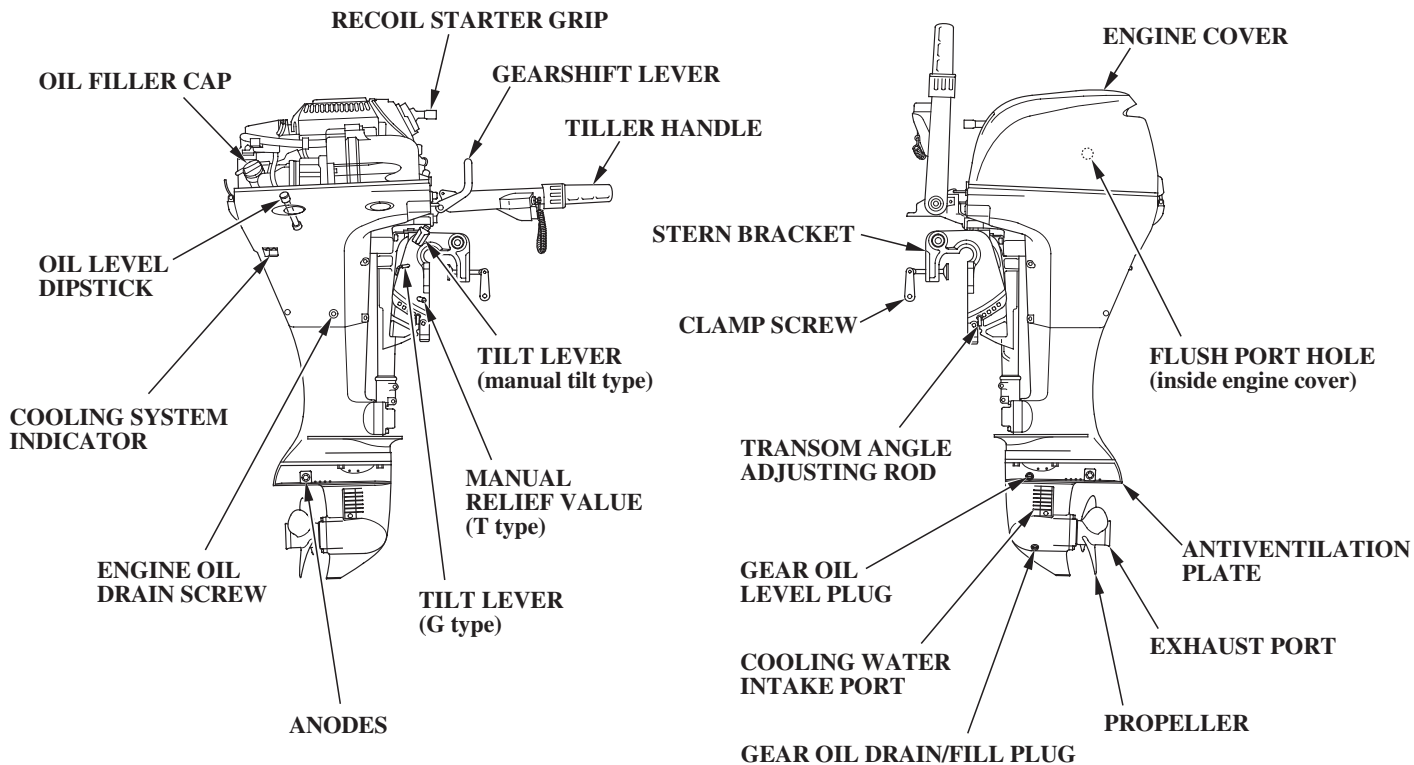



# CONTROLS AND FEATURES

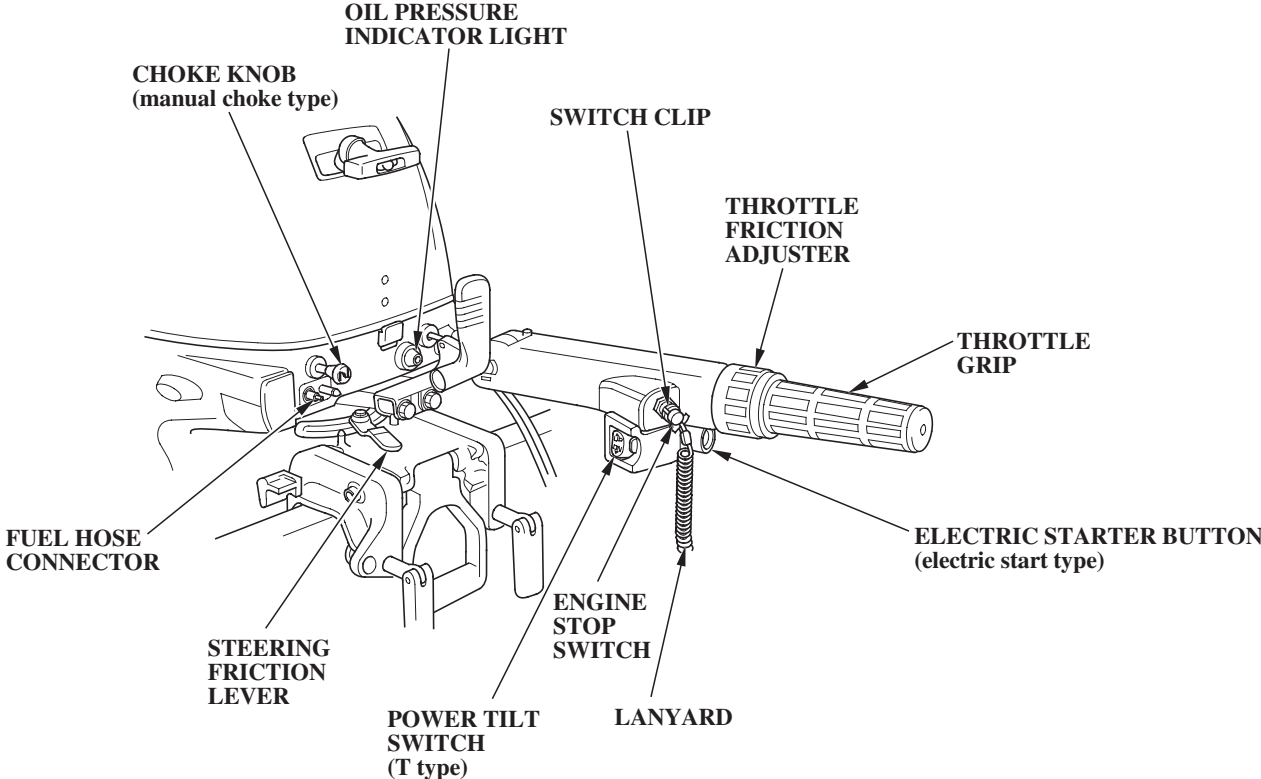

# CONTROLS AND FEATURES

---

## R Type (remote control)

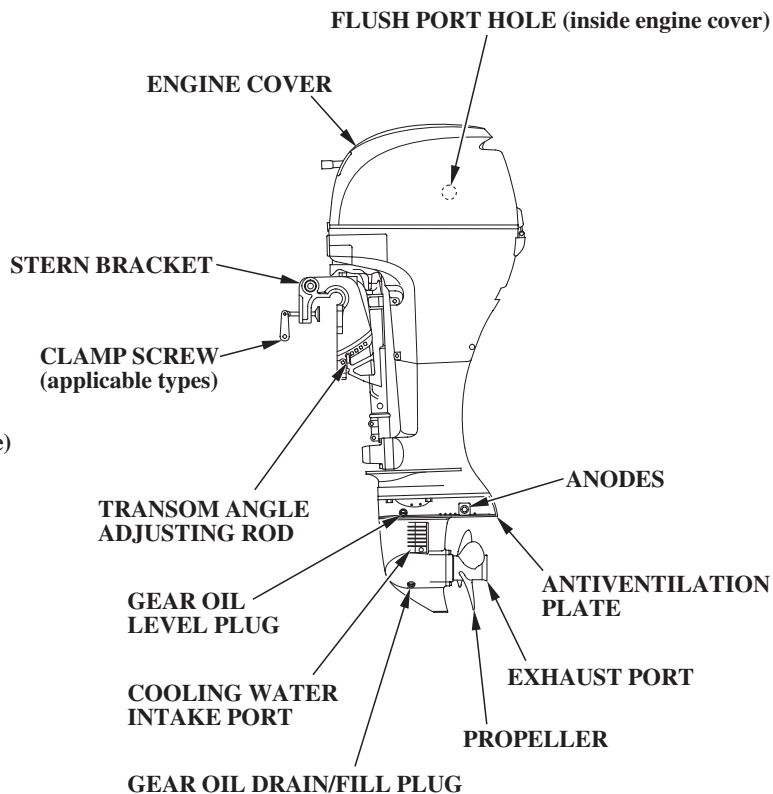
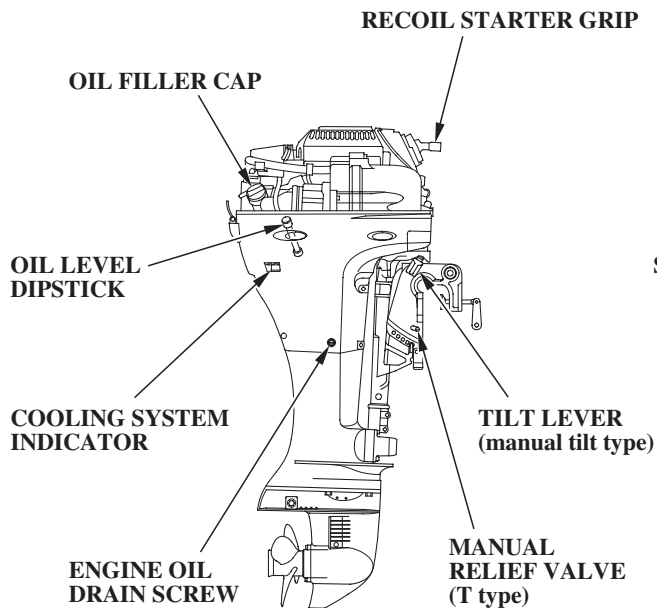

**Remote Control box (side-mount type)**

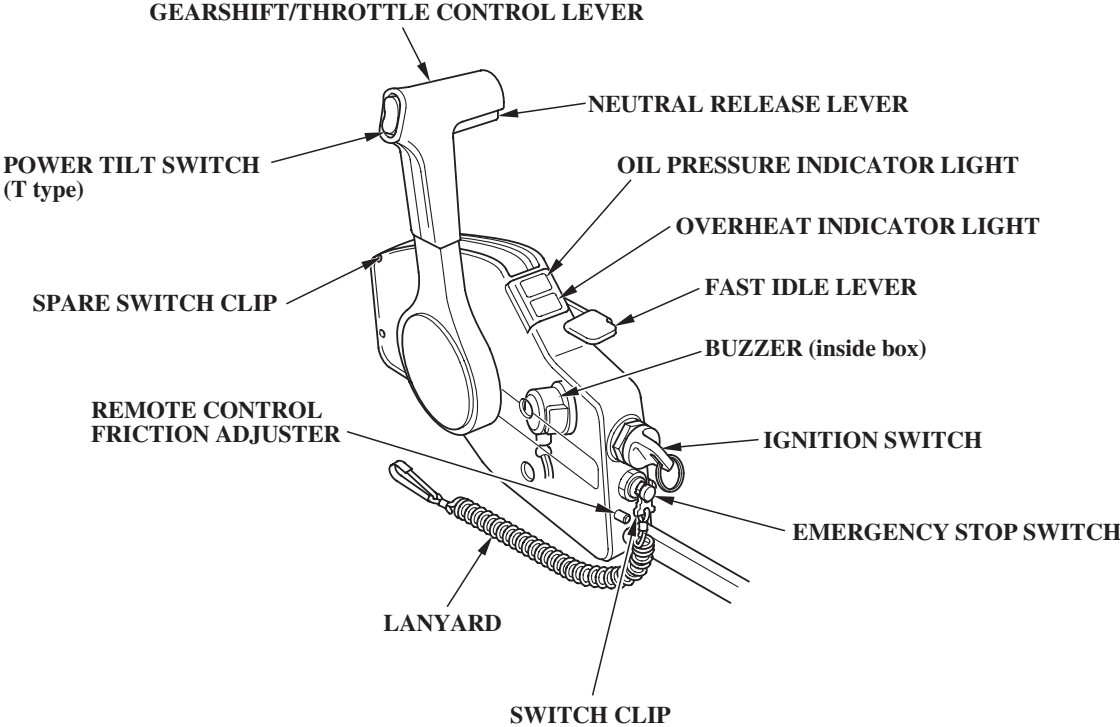

# CONTROLS AND FEATURES

---

## Tachometer [optional equipment (R type)]

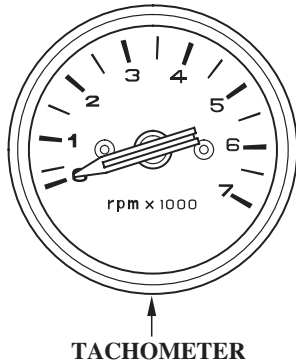

## Fuel Tank

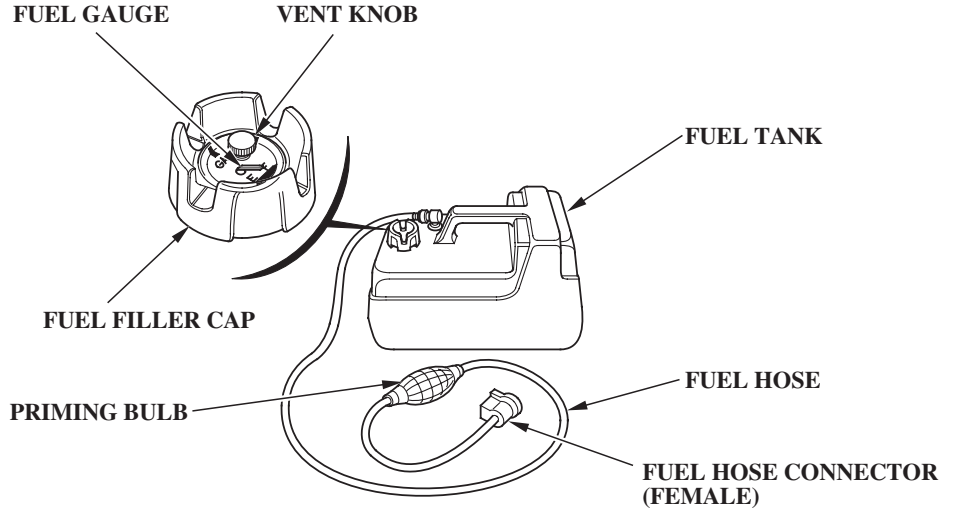

## CONTROLS

### H Type (tiller handle)

#### *Engine Stop Switch and Switch Clip*

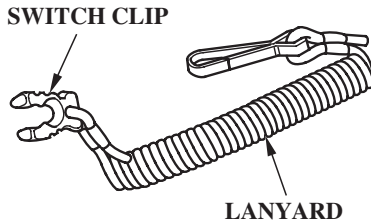
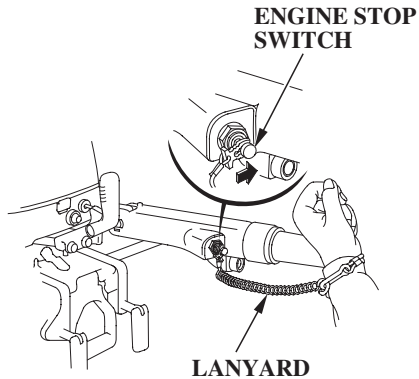

The engine stop switch has controls for normal engine stopping and emergency engine stopping.

The switch clip must be inserted in the engine stop switch in order for the engine to start and run. The lanyard should be attached to the operator's PFD (Personal Flotation Device) or worn around the wrist as shown.

When used as described, the engine stop switch and lanyard system stops the engine if the operator falls away from the controls.

A spare switch clip is supplied with the motor.

#### *Choke Knob (manual choke type)*

##### CHOKE KNOB

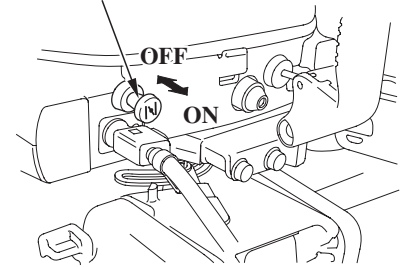

The choke knob opens and closes the choke valve in the carburetor.

The ON position enriches the fuel mixture for starting a cold engine.

The OFF position provides the correct fuel mixture for operation after starting, and for restarting a warm engine.

# CONTROLS AND FEATURES

## *Throttle Grip*

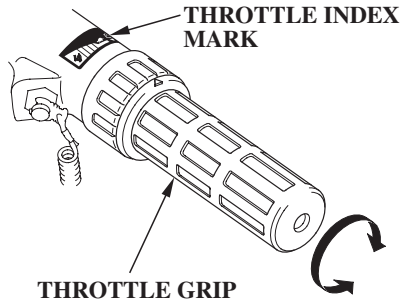

The throttle grip controls engine speed.

An index mark on the tiller arm shows throttle position and is helpful for setting the throttle correctly when starting (p. 46).

## *Throttle Friction Adjuster*

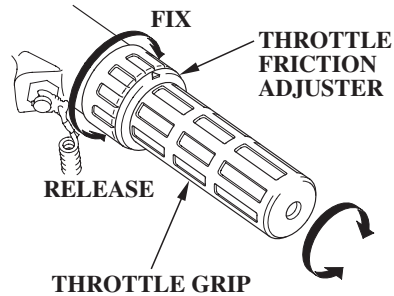

The throttle friction adjuster adjusts resistance to throttle grip rotation.

Turn the adjuster clockwise to increase friction for holding a throttle setting while cruising.

Turn the adjuster counterclockwise to decrease friction for easy throttle grip rotation.

## *Gearshift Lever*

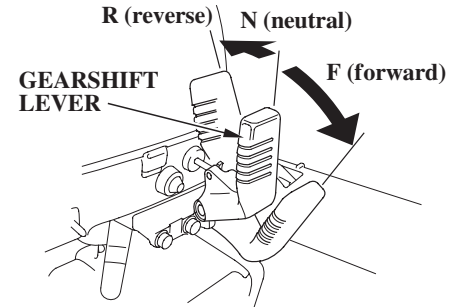

The gearshift lever is used to select F (forward), N (neutral), or R (reverse) gears.

The engine can be started with the gearshift lever in the N (neutral) position only.

If the gearshift lever is in the F (forward) or R (reverse) position, the recoil starter will not operate, and the electric starter button (applicable models) will not operate the starter motor.

## *Recoil Starter Grip*

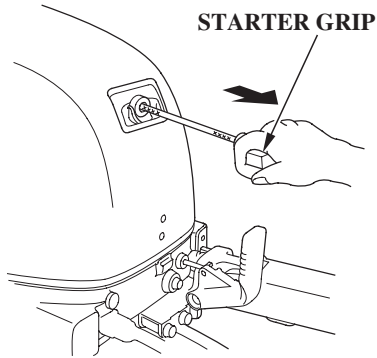

Pull the starter grip to operate the recoil starter for starting the engine manually.

The engine will not start unless the gearshift lever is in the N (neutral) position (p. 46 ), and the clip is in the engine stop switch.

## *Electric Starter Button (types equipped with electric starter)*

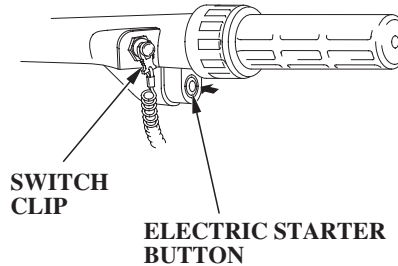

Press the starter button to operate the electric starter for starting the engine.

The electric starter button can be used to start the engine only when the gearshift lever is in the N (neutral) position (p. 46 ), and the clip is in the engine stop switch.

## *Steering Friction Lever*

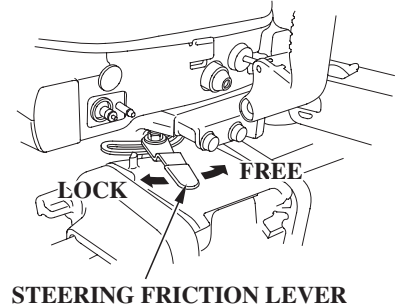

The steering friction lever adjusts steering resistance.

Less friction allows the outboard motor to turn more easily. More friction helps to hold steady course while cruising or to prevent the outboard motor from swinging while trailering the boat.

## CONTROLS AND FEATURES

### *Power Tilt Switch (T type)*

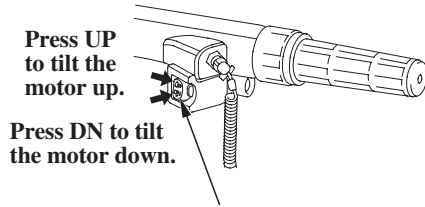

**POWER TILT SWITCH**

The rocker type power tilt switch has UP and DN (down) positions for changing the angle of the outboard motor.

**Power tilt is a convenience for tilting the motor, shallow water operation, and trailering only. It is not designed to be used as a trim function to adjust the trim angle of the boat.**

During shallow water operation, beaching, launching, or mooring, proceed at low speed with a small throttle opening and tilt the motor up as necessary (p. 60).

### *Tilt Lever (G type)*

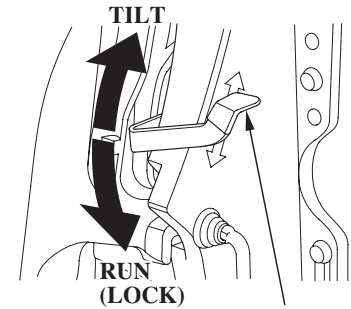

**TILT LEVER**

Moving the tilt lever to the TILT position allows the outboard motor to be tilted and moving the tilt lever to the RUN (LOCK) position locks the outboard motor in the desired position. Use the tilt lever to temporarily tilt the outboard motor when the boat is operating in shallow water, or mooring in shallow water. The tilt lever must be in the RUN (LOCK) position before operating the outboard motor or the motor could tilt up when operating in reverse.



## R Type (remote control)

For panel mount or top mount remote control information, refer to the instructions provided with the remote control equipment.

### *Ignition Switch (side-mount type)*

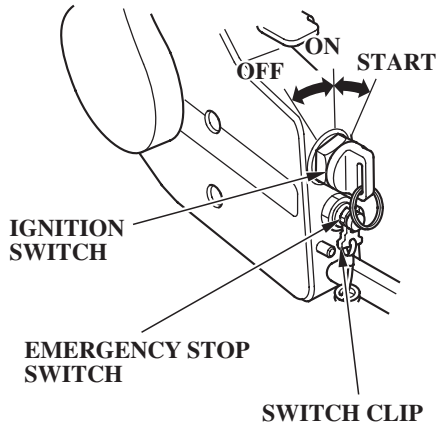

The ignition switch controls the ignition system and starter motor.

Turning the ignition switch key to the START position operates the starter motor. The key automatically returns to the ON position when released from the START position.

The ignition switch can be used to start the engine only when the gearshift lever is in the N (neutral) position (p. 48), and the switch clip is in the emergency stop switch.

Turning the ignition switch to the OFF position stops the engine.

### *Emergency Stop Switch and Switch Clip (side-mount type)*

#### EMERGENCY STOP SWITCH

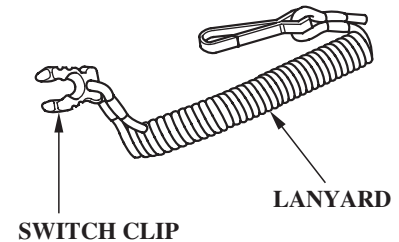
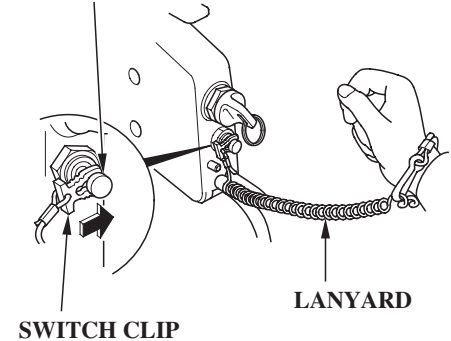

# CONTROLS AND FEATURES

The switch clip must be inserted in the emergency stop switch in order for the engine to start and run. The lanyard must be attached to the operator's PFD (Personal Flotation Device) or worn around the wrist as shown.

When used as described, the emergency stop switch and lanyard system stops the engine if the operator falls away from the controls.

A spare switch clip is stored in a slot in the control housing.

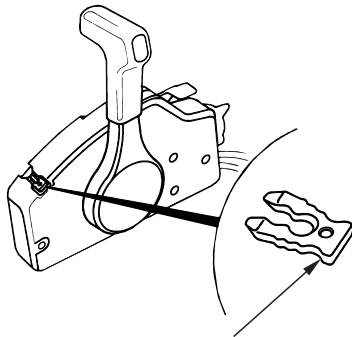

**SPARE SWITCH CLIP**

## *Fast Idle Lever*

*(side-mount type)*

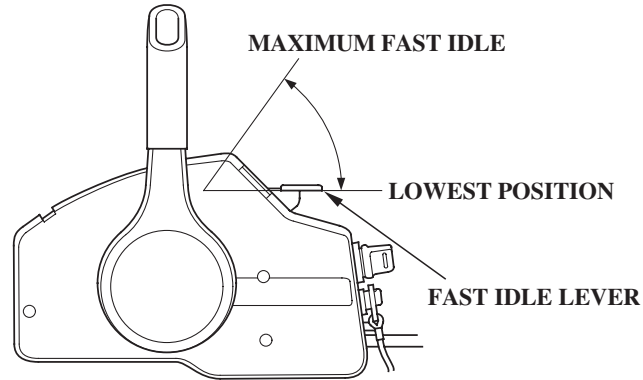

The fast idle lever is used to set idle speed during warm-up.

The lever will not move unless the gearshift/throttle control lever is in the N (neutral) position. The fast idle lever must be in its lowest position for you to move the gearshift/throttle control lever out of neutral.

Leave the fast idle lever in the lowest position to provide a rich fuel mixture for starting a cold engine.

Lift the fast idle lever to accelerate the warm up of a cold engine after starting and to start a warm engine.

## *Gearshift/Throttle Control Lever (side-mount type)*

GEARSHIFT/THROTTLE CONTROL LEVER

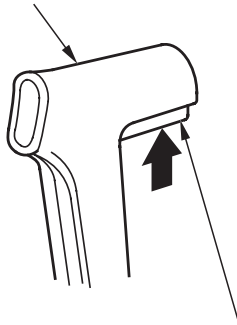

NEUTRAL RELEASE LEVER

The control lever automatically locks itself in the N (neutral) position. To move the lever out of the N (neutral) position, you must squeeze the neutral release lever on the underside of the lever handle.

GEARSHIFT/THROTTLE CONTROL LEVER

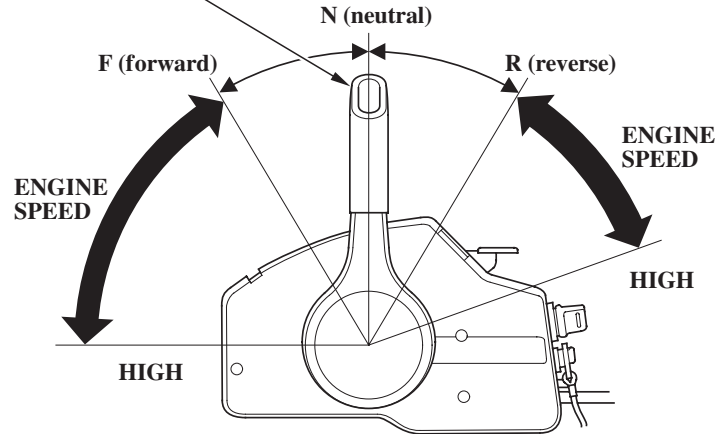

The gearshift/throttle control lever controls engine speed and selects F (forward), N (neutral), or R (reverse) gears.

Moving the control lever 30° from N (neutral) selects the gear, and further movement increases engine speed.

A friction adjuster near the base of the control lever adjusts the operating resistance of the control lever (p. 56).

Less friction allows easier control lever movement. More friction helps to hold a steady throttle setting while cruising.

## CONTROLS AND FEATURES

### *Power Tilt Switch (T type) (side-mount type)*

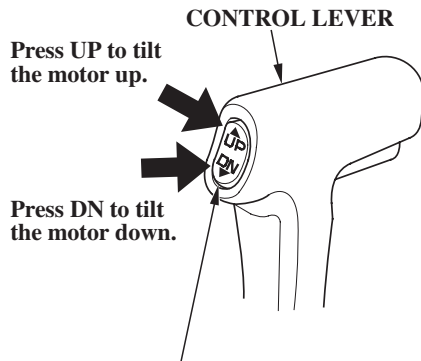

#### POWER TILT SWITCH

The rocker type power tilt switch is located on the control lever and has UP and DN (down) positions for changing the angle of the outboard motor.

Power tilt is a convenience for tilting the motor, shallow water operation, and trailering only. It is not designed to be used as a trim function to adjust the trim angle of the boat.

During shallow water operation, beaching, launching, or mooring, proceed at low speed with a small throttle opening and tilt the motor up as necessary (p. 61).

### *Manual Relief Valve (T type)*

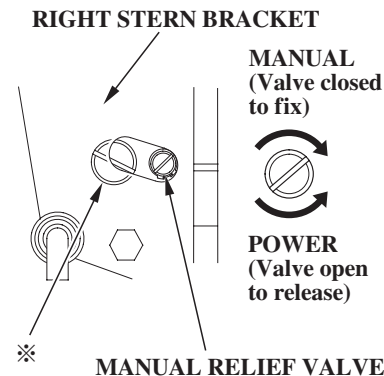

※ : Do not turn this screw. If this screw is turned hydraulic oil will bleed out of the power tilt system. Should this happen it will be necessary to consult your authorized Honda marine dealer and have the system refilled.

The outboard motor can be tilted manually after opening the manual relief valve. This allows the outboard motor to be tilted when no battery is connected.

## Tilt Lock Lever (G and T type)



The tilt lock lever is used to support the outboard motor in the fully-raised position.

When the boat is to be moored for a long time, tilt the outboard motor as far as it will go. Then move the tilt lock lever to the LOCK position, and gently lower the outboard motor until the lever contacts the stern bracket.

## Common Controls

### Engine Cover Latch

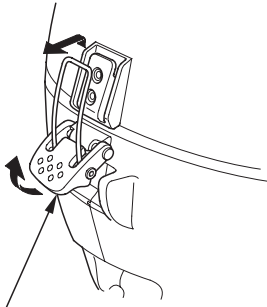

ENGINE COVER LATCH

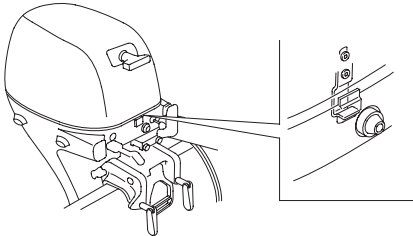

The engine cover latch fastens the engine cover to the outboard motor.

## Transom Angle Adjusting Rod

The transom angle adjusting rod limits the tilt angle of the outboard motor when fully lowered.

(manual tilt SH type/LH type)

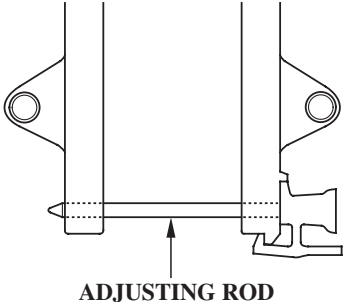

## CONTROLS AND FEATURES

(manual tilt/XH type and R type)

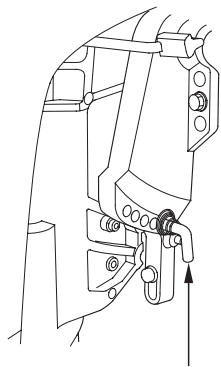

ADJUSTING ROD

(G and T type)

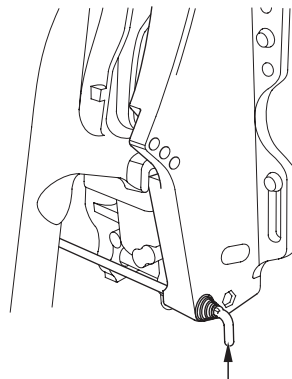

ADJUSTING ROD  
(storage location)

There are four transom angle adjustment positions. Three are controlled by the adjusting rod and the fourth is controlled by the stern bracket. In order to use the fourth position, remove the adjusting rod and store it in the storage location, then lower the motor down to the stern bracket stop position.

*Tilt Lever*  
(manual tilt type)

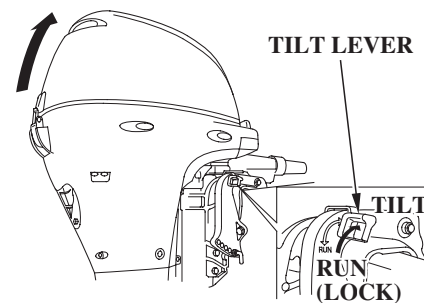

The tilt lever enables the outboard motor to be raised for shallow water operation, beaching, launching, or mooring.

To tilt, move the lever to the TILT position, then raise the outboard motor until the tilt mechanism engages at 30°, 45°, 71° or 72° (p. 60).

## CONTROLS AND FEATURES

BF8D/BFP8D/BF9.9D/BFP9.9D

71° : Tiller handle S and L type.

72° : Tiller handle X type and  
Remote control type.

BF15D/BFP15D/BF20D/BFP20D

71° : Tiller handle S type.

72° : Tiller handle L and X type and  
Remote control type.

### INSTRUMENTS

#### *Fuel Gauge*

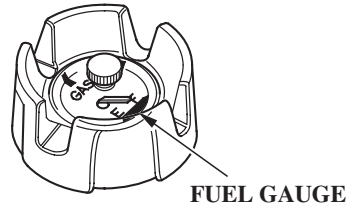

A fuel gauge is built into the cap of the portable fuel tank.

#### **Tachometer**

*[optional equipment (R Type)]*

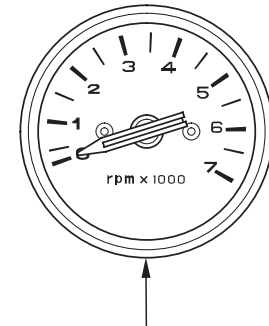

**TACHOMETER**

The tachometer shows engine speed in revolutions per minute.

A tachometer will help to select the correct propeller.

# CONTROLS AND FEATURES

## INDICATORS

### *Oil Pressure Indicator [R type (side-mount type)]*

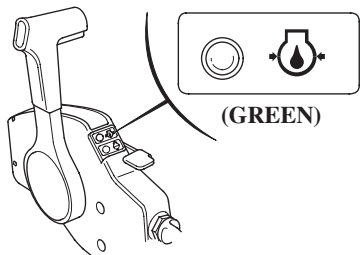

### *(H type)*

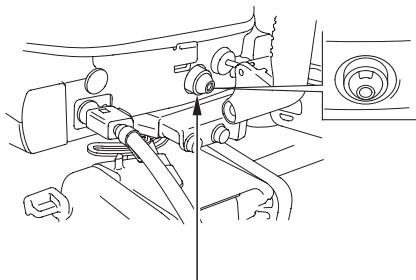

**OIL PRESSURE INDICATOR LIGHT**

When the green light is lit, oil pressure is OK.

If oil pressure becomes low, the green light will go off, and the engine protection system will limit engine speed. Refer to *TAKING CARE OF UNEXPECTED PROBLEMS*, p. 100.

Remote controls are also equipped with a buzzer that sounds continuously when the green light goes off.

The buzzer sound stops below an engine speed of 1,400 rpm.

Low oil pressure indicates that the engine oil level is low, or that there is a problem with the engine lubrication system.

### *Overheat Indicator [R type (side-mount type)]*

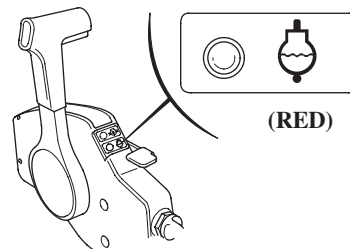

### **(R type)**

When the overheat protection system is activated, the red overheat light will come on, a buzzer will sound continuously and the engine speed will be reduced to 1,800 rpm. If the condition persists for another 20 seconds, the engine will shut off. Refer to *TAKING CARE OF UNEXPECTED PROBLEMS*, p. 101.



### (H type)

When the overheat protection system is activated, the engine speed will be reduced to 1,800 rpm. If the condition persists for another 20 seconds, the engine will shut off. Refer to *TAKING CARE OF UNEXPECTED PROBLEMS*, p. 101.

Engine overheating may be the result of clogged water intakes.

### *Cooling System Indicator*

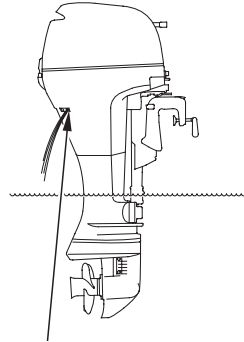

#### **COOLING SYSTEM INDICATOR**

Water should flow from the cooling system indicator while the engine is running. This shows that water is circulating through the cooling system.

If water stops flowing while the engine is running, that indicates a cooling system problem, such as clogged water intakes, which will cause engine overheating. Refer to *TAKING CARE OF UNEXPECTED PROBLEMS*, on p. 101.

The cooling system indicator port can also become plugged.

# CONTROLS AND FEATURES

---

## OTHER FEATURES

### *Overrev Limiter*

The engine is equipped with an overrev limiter to prevent the possibility of mechanical damage from excessive engine speed.

The overrev limiter may be activated during operation, limiting engine speed, if the outboard motor is tilted excessively, or when propeller ventilation occurs during a sharp turn.

If the overrev limiter is activated, check the tilt angle of the outboard motor.

### *Automatic Choke (types equipped with electric starter)*

The engine is equipped with an automatic choke so that the choke system operation is not needed when starting the engine.

### *Anodes*

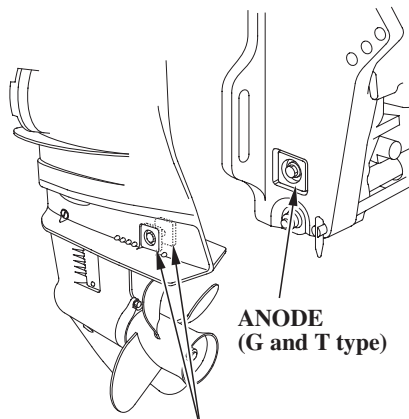

**ANODES (each side)**

The anodes are made of a sacrificial material that helps to protect the outboard motor from corrosion.

There are two anodes on the gear case, one on the stern bracket.

### *Portable Fuel Tank*

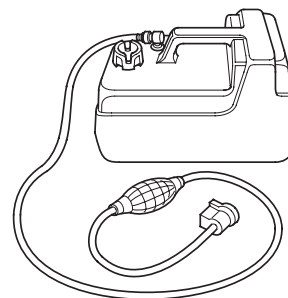

The portable fuel tank has a capacity of 3.2 US gal (12ℓ) and has a fuel gauge built into the cap.

### *Fuel Filler Cap Vent Knob*

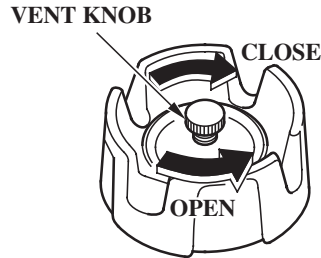

The cap is provided with a vent knob to seal the portable fuel tank for carrying it to and from the boat. Open the vent knob 2 or 3 turns before starting the engine.

### *Fuel Priming Bulb*

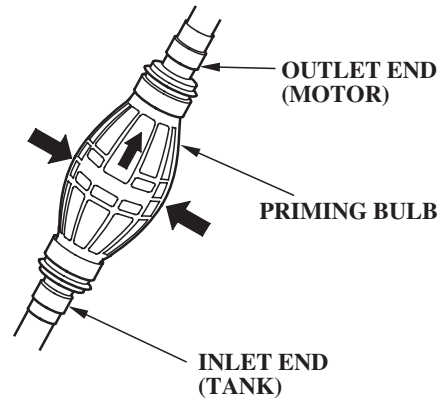

A priming bulb is built into the fuel hose that connects the fuel tank to the outboard motor.

Before starting the engine, squeeze the priming bulb until it feels firm. This will ensure that fuel is supplied to the engine.

# INSTALLATION

Correct and secure installation is essential for safe boating and good performance. Follow the installation instructions provided in this manual.

## POWER REQUIREMENTS

Before installation, check to be sure that the outboard motor does not exceed the recommended maximum horsepower for the boat on which it is to be installed. Refer to the boat's certification plate for recommended maximum horsepower. If the certification plate information is not available, contact the boat dealer or manufacturer.

For most applications, the outboard motor should have a horsepower rating which provides 80% of the maximum recommended horsepower for the boat.

## BOAT TRANSOM REQUIREMENTS

Honda BF8D/BFP8D/BF9.9D/BFP9.9D/BF15D/BFP15D/BF20D and BFP20D outboard motors can be installed on a boat transom having a thickness range of 1.3 – 2.2 inches (35 – 57 mm).

## INSTALLATION POSITION

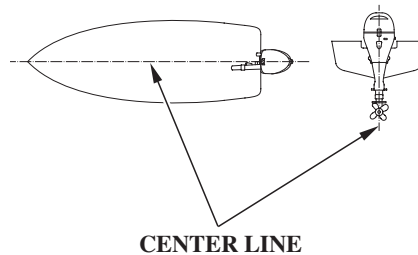

Install the outboard motor on the center of the boat transom.

The antiventilation plate of the outboard motor should be 0 – 2.0 in (0 – 50 mm) below the bottom of the boat.

The correct dimensions differ according to the type of the boats and the configuration of the bottom of the boats. Follow the manufacturer's recommended installation height.

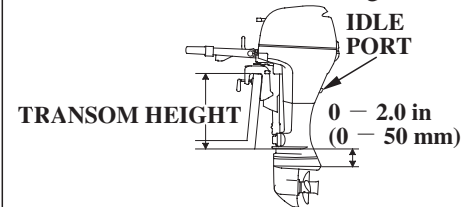

Type:	Transom Height
S:	17.0 in (433 mm)
L:	22.2 in (563 mm)
X:	27.7 in (703 mm)

When the outboard motor is installed extremely low, the idle port may be immersed and the engine may become hard to start or may run poorly. Check that the idle port is high enough from the water level when the engine is stopped with the boat fully loaded.

If the outboard motor is installed too low, the boat will squat and be hard to plane, and the motor will spray water that may enter the boat. It will tend to porpoise, and high-speed stability will be reduced.

If the outboard motor is installed too high, that will cause propeller ventilation.

Optimum installation height varies with boat type and bottom shape. Contact the boat manufacturer for any special recommendations that are unique to a specific model of boat.

If the transom needs to be modified to accommodate the outboard motor, contact the boat manufacturer and follow their recommendations for corrective action.

## ATTACHMENT (types with clamp screws)

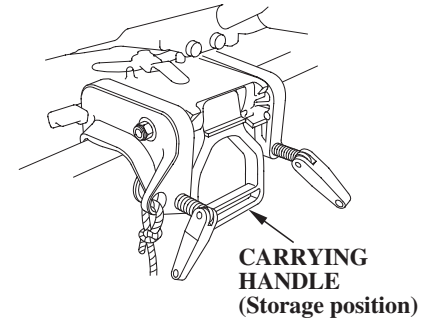
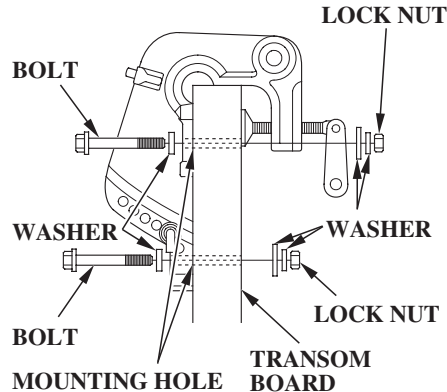
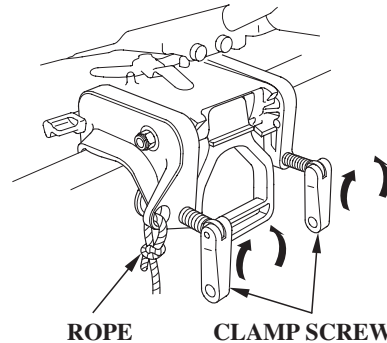

Attach the stern bracket to the transom and tighten the clamp screws. Push the carrying handle into the storage position.

Attach a rope from the boat to the hole in the stern bracket. This will help to prevent accidental loss of the outboard motor.

You may further secure the outboard motor by bolting the stern bracket to the boat transom. Use the optional mounting bolt and nut kit or other good quality stainless steel bolts, nuts, and washers. Apply silicone sealant to the bolt holes.

# INSTALLATION

(types without clamp screws)

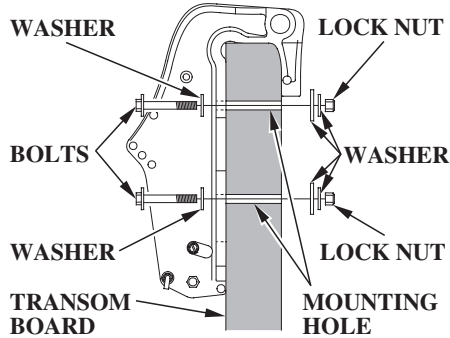

Attach the stern bracket to the boat transom with good quality stainless steel bolts, nuts, and washers. Apply silicone sealant to the bolts holes.

## TRANSOM ANGLE ADJUSTMENT

Use the transom angle adjustment rod (p. 42) to adjust the angle of the outboard motor so the propeller is perpendicular to the surface of the water.

## BATTERY CONNECTIONS

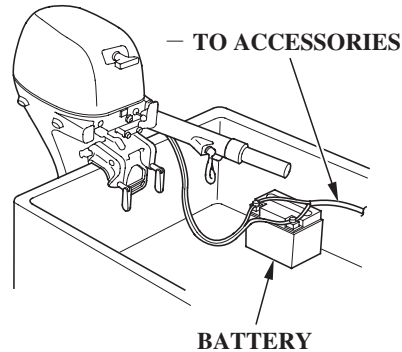

Honda BF8D/BFP8D/BF9.9D/BFP9.9D/BF15D/BFP15D/BF20D and BFP20D outboard motors produce a 12-volt, 6 or 12-ampere battery-charging current and are equipped for connection to a 12-volt battery. The battery-charging circuit is protected by a 20-ampere fuse located in the engine compartment.

The outboard motor's 12-volt output is designed to charge a "starting or cranking" battery only. It is not intended to charge a "deep-cycle" type battery. Lights and electrical accessories for the boat should be connected to the battery.

The battery should be kept in a corrosion-resistant battery box that is securely mounted in a location away from the fuel tank and protected from water and direct sunlight.

## Types With Electric Starter

These types are equipped with battery cables. The positive (+) cable has a red band at the battery connector. The negative (-) cable has a black band at the battery connector.

For electric starter operation, use a 12-volt battery with an ampere-hour rating of at least 35 Ah (CCA 270).

## Types With Manual Start

These types are equipped with a 12-volt DC battery-charging receptacle which can be wired to a 12-volt battery to power lights and electrical accessories for the boat.

## Plug and Receptacle (types without electric starter)

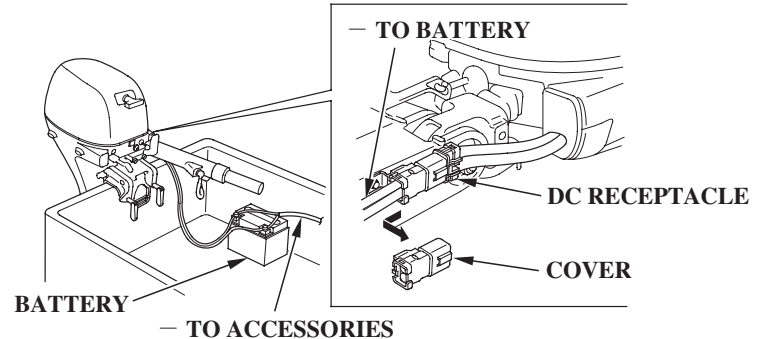

To prepare the outboard motor for connection to a battery, pull the cover off the DC receptacle, connect the battery charging wires to the plug. Attach the plug to the receptacle on the motor.

The receptacle is provided with a cover, which should be attached when the plug is removed, in order to keep the receptacle clean and dry.

## Battery

For complete information, refer to the battery manufacturer's instructions.

## Minimum Requirements

12V-35Ah (CCA 270)

# INSTALLATION

---

## Battery Terminals

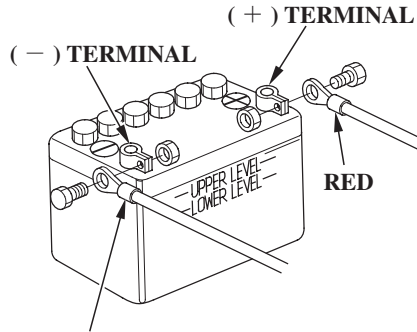

**BLACK or GREEN**

Connect the positive (+) battery cable to the positive (+) battery terminal, then connect the negative (-) battery cable to the negative (-) battery terminal.

The negative (-) battery cable should always be removed from the battery before connecting or disconnecting the positive (+) battery cable, so tools cannot cause a short circuit if they touch a grounded part while being used on the positive (+) battery terminal fitting.

### NOTICE

*Be careful to avoid connecting the battery in reverse polarity, as that will damage the battery-charging system in the outboard motor.*



## BEFORE OPERATION

### ARE YOU READY TO GET UNDER WAY?

Your safety is your responsibility. A little time spent in preparation will significantly reduce your risk of injury.

### Knowledge

Read and understand this manual. Know what the controls do and how to operate them.

Familiarize yourself with the outboard motor and its operation before you get under way. Know what to do in case of emergencies.

Familiarize yourself with all laws and regulations relating to boating and the use of outboard motors.

### Safety

Always wear a PFD (Personal Flotation Device) while on the boat.

Attach the emergency stop switch lanyard securely to your PFD or to your wrist.

### IS YOUR OUTBOARD MOTOR READY TO GO?

For your safety, and to maximize the service life of your equipment, it is very important to take a few moments before you operate the outboard motor to check its condition. Be sure to take care of any problem you find, or have your authorized Honda marine dealer correct it, before you operate the outboard motor.

### WARNING

Improperly maintaining this outboard motor, or failing to correct a problem before operation, can cause a malfunction in which you could be seriously hurt or killed.

Always perform a preoperation inspection before each operation, and correct any problem.

Before beginning your preoperation checks, be sure the ignition switch is in the OFF position.

# BEFORE OPERATION

---

## Safety Inspection

- Look around the outboard motor for signs of oil or gasoline leaks.
- If you are using the portable fuel tank, make sure it is in good condition and properly secured in the boat (p. 44).
- Check that the fuel hose is undamaged and properly connected (p. 44).
- Wipe up any spills before starting the engine.
- Check the stern bracket to be sure the outboard motor is securely installed.
- Check that all controls are operating properly.
- Replace any damaged parts.
- Check that all fasteners are in place and securely tightened.

## Maintenance Inspection

- Check the engine oil level (p. 71). Running the engine with a low oil level can cause engine damage.
- Check to be sure the propeller is undamaged, and the castle nut is secured with the cotter pin (p. 86).
- Check that the anodes are securely attached to the gear case (p. 84) and are not excessively worn. The anodes help to protect the outboard motor from corrosion.
- Make sure the tool kit and emergency starter rope are onboard (p. 67). Replace any missing items.
- Check the fuel level in the fuel tank (p. 79).
- Check that the battery fluid is between the upper and lower levels, and the battery leads are connected securely (electric starter type).

## SAFE OPERATING PRECAUTIONS

To safely realize the full potential of this outboard motor, you need a complete understanding of its operation and a certain amount of practice with its controls.

Before operating the outboard motor for the first time, please review the *IMPORTANT SAFETY INFORMATION* on page 7 and the chapter titled *BEFORE OPERATION*.

For your safety, avoid starting or operating the engine in an enclosed area. Your engine's exhaust contains poisonous carbon monoxide gas which can collect rapidly in an enclosed area and cause illness or death.

## BREAK-IN PROCEDURE

### Break-in period: 10 hours

Proper break-in operation allows the moving parts to wear in smoothly for best performance and long service life.

#### First 15 minutes:

Run the engine at trolling speed. Use the minimum throttle opening necessary to operate the boat at a safe trolling speed.

#### Next 45 minutes:

Run the engine up to a maximum of 2,000 to 3,000 rpm, which is about 10% to 30% of maximum throttle opening.

#### Next 60 minutes:

Run the engine up to a maximum of 4,000 to 5,000 rpm, which is about 50% to 80% of maximum throttle opening.

Short full-throttle bursts are OK, but do not operate the engine continuously at full throttle.

For boats that plane easily, bring the boat up on plane, and then reduce the throttle opening to the recommended rpm range.

#### Next 8 hours:

Do not run the engine at full throttle for more than 5 minutes at a time.

# OPERATION

## TRANSOM ANGLE ADJUSTMENT

(manual tilt SH type/LH type)

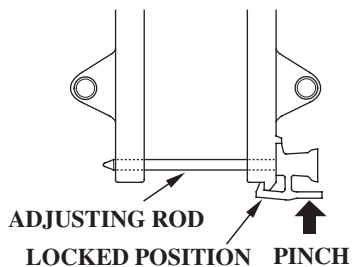

(manual tilt XH type/R type)

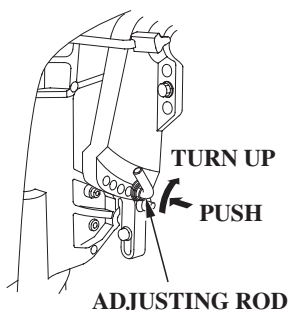

(G type/T type)

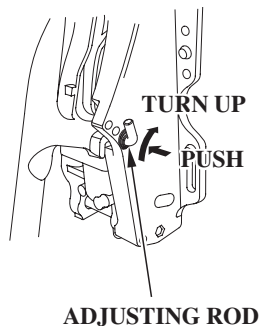

(XH type/R type/ G type/T type)

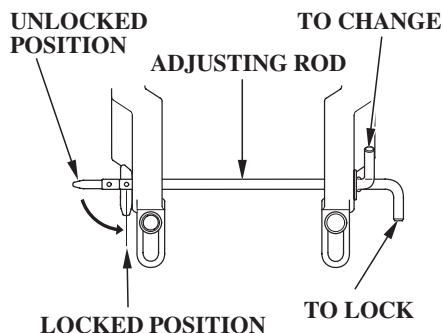

The transom angle adjusting rod limits the tilt angle of the outboard motor when fully lowered.

Proper adjustment prevents the outboard motor from being tilted too low (p. 58).

To adjust, first tilt the outboard motor so it is not resting on the rod.

(manual tilt SH type/LH type)  
Pinch the end of the rod.

Remove the rod and reinsert it in the desired position.

Push the rod in and hook the end of the rod. Then release the rod.

(XH type/R type/ G type/T type)  
Push the rod in and turn the end of the rod up, so the latch will fall into line with the rod.  
Push the rod in and turn the end of the rod down, so the latch will fall to the locked position. Then release the rod.

**NOTICE**

*Do not allow water to enter the idle exhaust port or the engine can be damaged.*

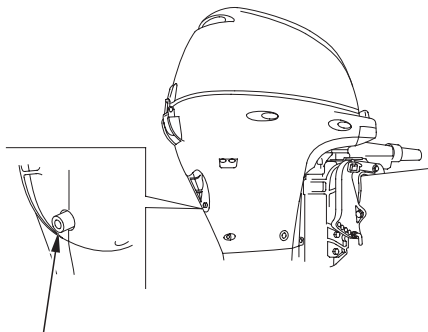

**IDLE EXHAUST PORT**

## OPERATION

### PORTABLE FUEL TANK

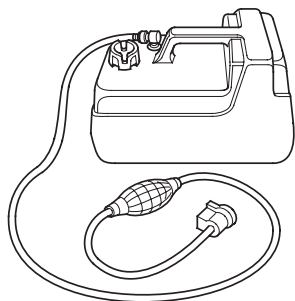

Place the portable fuel tank in a well-ventilated location, away from direct sunlight, to reduce the possibility of a gasoline vapor explosion.

To ensure that the outboard motor will be able to draw fuel from the tank, place the tank within 6 feet of the outboard motor and not more than 3 feet below the fuel connector on the outboard motor.

Secure the portable fuel tank in the boat, so it won't move around and become damaged.

Before use, open the fuel tank vent by turning the vent knob at least 2 or 3 turns counterclockwise.

#### **⚠ WARNING**

Gasoline is highly flammable and explosive.

You can be burned or seriously injured when handling fuel.

- Stop the engine and keep heat, sparks, and flame away.
- Handle fuel only outdoors.
- Wipe up spills immediately.

### FUEL HOSE CONNECTIONS

#### FUEL HOSE CONNECTOR

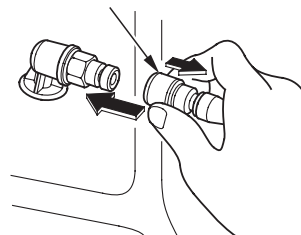

(FUEL TANK SIDE)

#### FUEL HOSE CONNECTOR

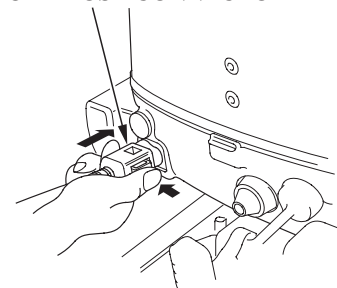

(OUTBOARD MOTOR SIDE)

Connect the fuel hose to the tank and the outboard motor, as shown. Be sure both connectors snap securely into place.

## FUEL PRIMING

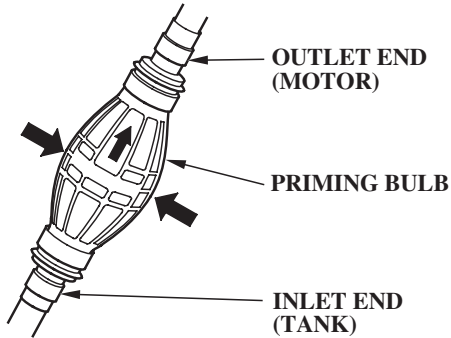

Hold the priming bulb with the outlet end higher than the inlet end. Squeeze the priming bulb several times, until it feels firm, indicating that fuel has reached the carburetor.

Check to be sure there are no fuel leaks before starting the engine.

Do not squeeze the priming bulb when the engine is running because that could flood the carburetor.

## STARTING THE ENGINE

### *H Type (tiller handle)*

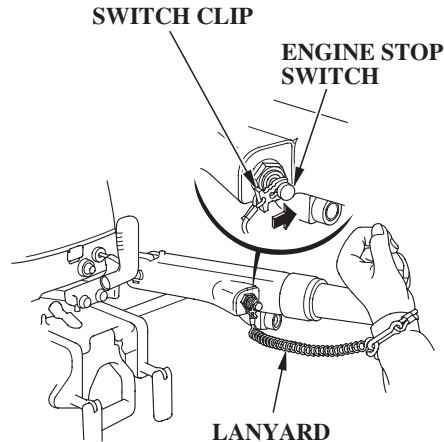

1. Put the emergency stop switch clip in the engine stop switch, and attach the lanyard to your PFD (Personal Flotation Device) or to your wrist, as shown.

The engine will not start or run, unless the switch clip is in the engine stop switch.

The emergency stop switch clip and lanyard system is a safety device that will stop the engine if you fall away from the controls while operating the boat.

Always attach the lanyard to your PFD, or to your wrist, before starting the engine.

## OPERATION

---

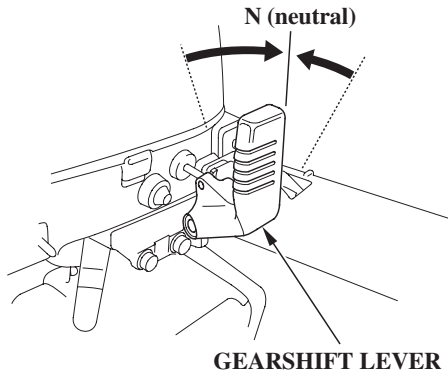

2. Check the position of the gearshift lever. It must be in the N (neutral) position for starting.

The engine will not start if the gearshift lever is in the F (forward) or R (reverse) position.

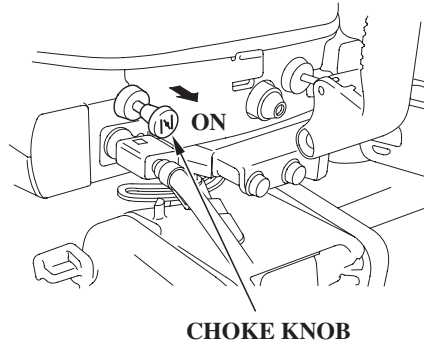

3. (Manual choke type)  
To start a cold engine, pull the choke knob to the ON position. To restart a warm engine, leave the choke knob in the OFF position.

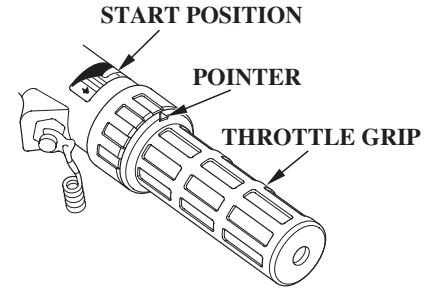

4. Turn the throttle grip to align the pointer with the START position to start the engine.



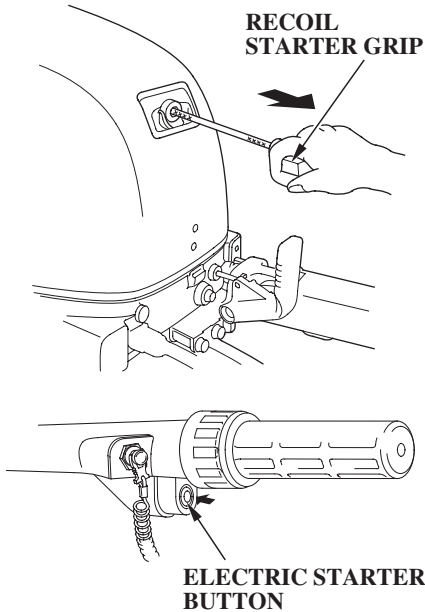

## 5. Recoil starter

Pull the recoil starter grip slowly until you feel resistance, then pull briskly.

Return the starter grip gently.

## Electric starter

(electric start type)

Press the electric starter button and hold it there until the engine starts.

When the engine starts, release the button.

If the engine fails to start within 5 seconds, release the button, and wait at least 10 seconds before operating the starter again.

### NOTICE

- *Using the electric starter for more than 5 seconds at a time will overheat the starter motor and can damage it.*
- *Pushing the electric starter button while the engine is running can damage the starter motor and flywheel.*

## 6. (Manual choke type)

If the choke knob was pulled to the ON position to start the engine, gradually push it to the OFF position as the engine warms up.

Also, as the engine warms up, the throttle grip can be turned to the SLOW position without stalling.

## 7. Before getting under way, allow the engine to warm up sufficiently to ensure good performance.

During the warm-up period, check the oil pressure indicator (p. 30) and cooling system indicator (p. 31).

If the indicators show any abnormal condition, immediately stop the engine and determine the cause of the problem. Refer to *TAKING CARE OF UNEXPECTED PROBLEMS*, p. 100.

## OPERATION

### R Type (remote control)

For panel mount or top mount remote control information, refer to the instructions provided with the remote control equipment.

#### *Side-Mount Type*

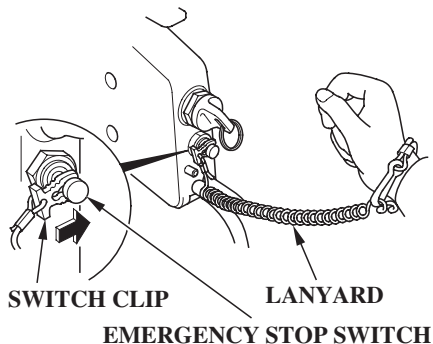

1. Put the emergency stop switch clip in the emergency stop switch, and attach the lanyard to your PFD (Personal Flotation Device) or to your wrist, as shown.

The engine will not start or run, unless the switch clip is in the emergency stop switch.

The emergency stop switch clip and lanyard system is a safety device that will stop the engine if you fall away from the controls while operating the boat.

Always attach the lanyard to your PFD, or to your wrist, before starting the engine.

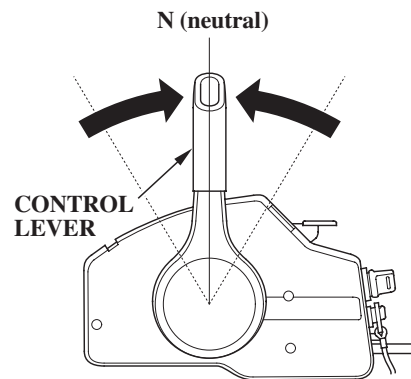

2. Set the control lever in the N (neutral) position.

The engine will not start if the F (forward) or R (reverse) gears are engaged.

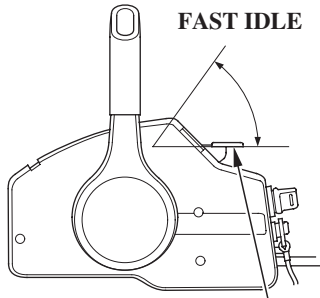

**FAST IDLE LEVER**

3. To start a cold engine, leave the fast idle lever in the OFF (fully lowered) position.

To restart a warm engine, raise the fast idle lever.

Fast idle lever cannot be raised unless the control lever is in the N (neutral) position.

The control lever cannot be moved away from the N (neutral) position unless the fast idle lever is lowered.

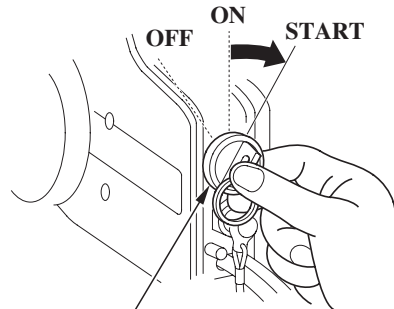

**IGNITION SWITCH KEY**

4. Turn the ignition switch key to the START position and hold it there until the engine starts.

When the engine starts, release the key, allowing it to return to the ON position.

If the engine fails to start within 5 seconds, release the key and wait at least 10 seconds before operating the starter again.

## NOTICE

- Using the electric starter for more than 5 seconds at a time will overheat the starter motor and can damage it.
- Turning the ignition switch key to the START position while the engine is running can damage the starter motor and flywheel.

## OPERATION

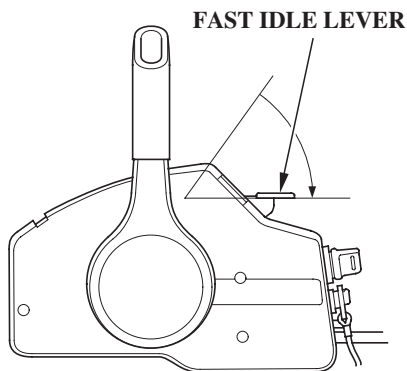

5. If the fast idle lever was used to start the engine, gradually lower the lever as the engine warms up.

When the fast idle lever is fully lowered, the control lever can be moved away from the N (neutral) position.

6. Before getting under way, allow the engine to warm up sufficiently to ensure good performance.

Above 41°F (5°C), warm up the engine for 2 or 3 minutes.

Below 41°F (5°C), warm up the engine for at least 10 minutes at 2,000 rpm.

During the warm-up period, check the oil pressure indicator (p. 30), overheat indicator (p. 30), and cooling system indicator (p. 31).

If the indicators show any abnormal condition, immediately stop the engine and determine the cause of the problem. Refer to *TAKING CARE OF UNEXPECTED PROBLEMS*, p.100.

## EMERGENCY STARTING

If the battery is discharged, or the starter motor and the recoil starter are inoperative, you can start the engine manually using the emergency starter rope supplied with the motor.

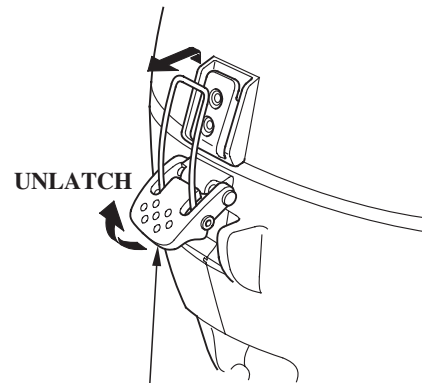

### ENGINE COVER LATCH

1. Unlatch and remove the engine cover (p. 70).

NEUTRAL START CABLE

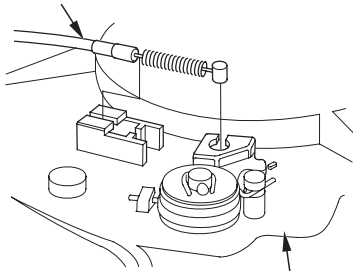

RECOIL STARTER ASSEMBLY

2. Move the shift lever to the F (forward) position. Loosen the neutral start cable lock nut and disconnect the neutral start cable.

FLANGE BOLT RECOIL STARTER ASSEMBLY

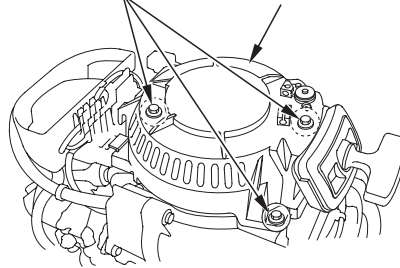

3. Unscrew the three flange bolts and remove the recoil starter assembly.
4. Set the controls the same as for normal starting (see pages 45 — 50 ). Use the choke and fast idle controls if needed.

Electric start type:

Turn the ignition switch key to the ON position.

5. Set the knotted end of the emergency starter rope in the notch in the flywheel. Wind the rope clockwise around the flywheel, as shown.

FLYWHEEL (STARTER PULLEY) STARTER ROPE KNOT

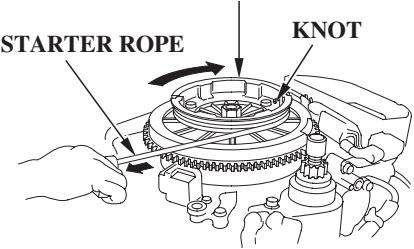

6. Pull the emergency starter rope slowly until resistance is felt, then pull briskly.

Keep away from moving parts while pulling the rope.

If necessary, rewind the rope and pull again. If the engine does not start after several attempts, refer to *TAKING CARE OF UNEXPECTED PROBLEMS*, p. 94.

## OPERATION

---

7. If the choke and fast idle control(s) were used to start the engine, return the control(s) to the normal operating position as the engine warms up.

During the warm-up period, check the oil pressure indicator (p. 30), overheat indicator (p. 30), and cooling system indicator (p. 31).

8. Leave the recoil starter assembly off, but install the engine cover (p. 70), and lock it in place by latching the engine cover latch.

### **WARNING**

Exposed moving parts can cause injury.

- Do not operate the outboard motor without the engine cover.
- Use extreme care when installing the engine cover.

9. If it was necessary to remove the emergency stop switch lanyard from your wrist to perform the emergency starting procedure, be sure the lanyard is attached to your wrist before operating the outboard motor.

10. Have your closest authorized Honda marine dealer check your electrical system and correct the problem, so you can use the electric starter.

The recoil starter assembly (p. 51) should be reinstalled after the electric starter is working again. Install the recoil starter assembly with the engine stopped.

## STOPPING THE ENGINE

### Emergency Engine Stopping

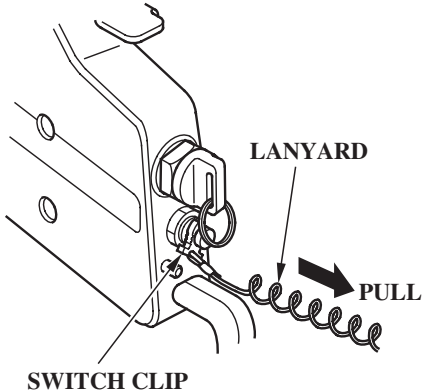
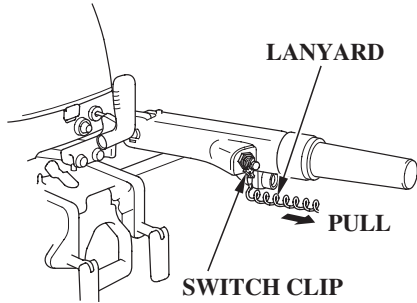

To stop the engine in an emergency, pull the switch clip out of the emergency stop switch by pulling the lanyard.

We suggest that you stop the engine this way occasionally to verify that the engine emergency stop switch is operating properly.

Turn the ignition switch key to the OFF position (electric start type) after verifying the emergency stop switch operation.

### Normal Engine Stopping

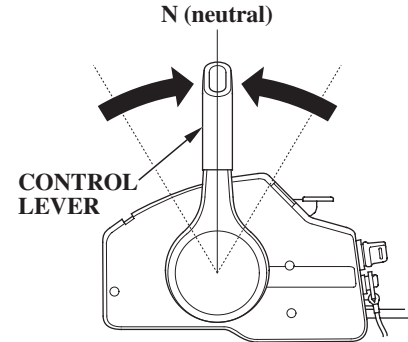
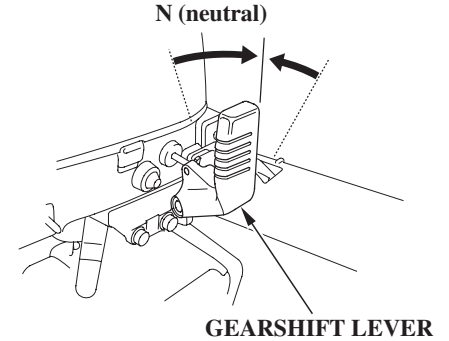
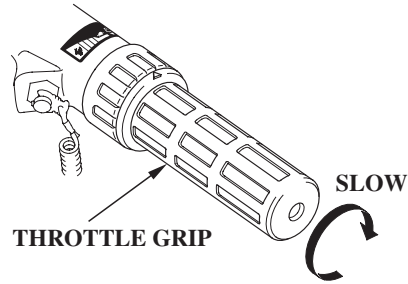

1. Move the throttle grip to the slowest position and the gearshift lever or the remote control lever to the N (neutral) position.

## OPERATION

---

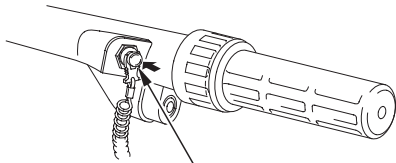

**ENGINE STOP SWITCH**

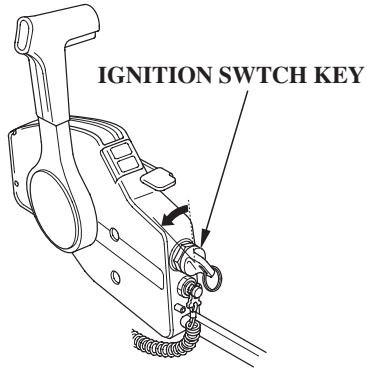

**IGNITION SWTCH KEY**

2. Turn the ignition switch key to the OFF position or press the engine stop switch until the engine stops.

3. When the boat is not in use, remove and store the ignition key and the emergency stop switch clip and lanyard.



## GEARSHIFT AND THROTTLE OPERATION

### H Type (tiller handle)

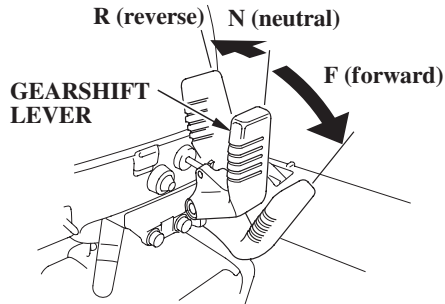
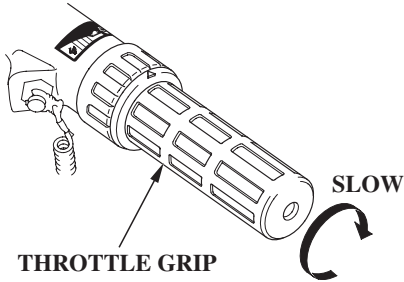

To shift gears, turn the throttle grip to the SLOW position, then move the gearshift lever to select F (forward), N (neutral) or R (reverse) gears.

The engine can be started with the gearshift lever in the N (neutral) position only.

The throttle grip can be turned to the FAST position only when the gearshift lever is in the F (forward) position.

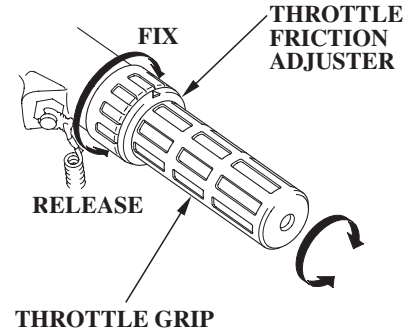

Use the throttle friction adjuster to help hold a constant throttle setting while cruising.

Turn the adjuster clockwise to increase throttle grip friction for holding a constant speed.

Turn the adjuster counterclockwise to decrease friction for easy grip rotation.

# OPERATION

## R Type (remote control)

### Side-Mount Type

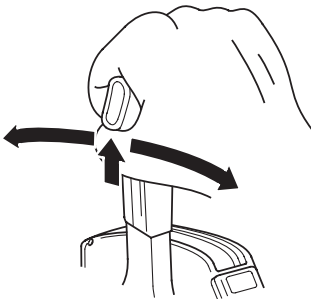
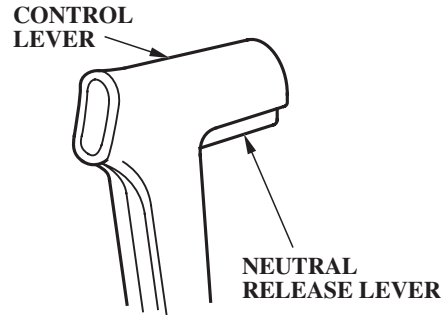

To shift gears, move the control lever to select F (forward), N (neutral) and R (reverse) gears.

The control lever cannot be moved from the N (neutral) position unless the neutral release lever is squeezed.

Moving the control lever beyond the gear selection range increases engine speed.

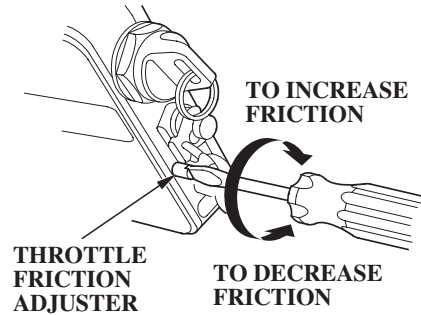

Adjust the throttle friction adjuster so the control lever will hold a constant throttle setting while cruising.

## STEERING

### H Type (tiller handle)

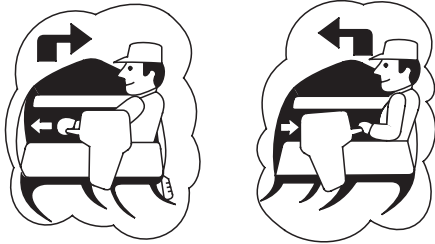

Steer by moving the tiller handle opposite the direction you want the boat to turn.

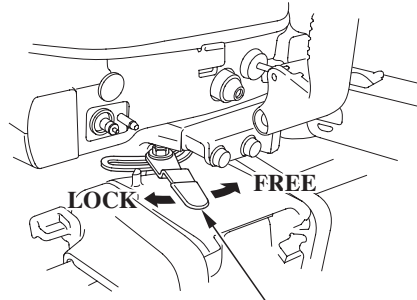

**STEERING FRICTION LEVER**

Use the steering friction lever to help hold a steady course while cruising.

Move the lever to the **LOCK** direction to increase steering friction for holding a steady course and for trailering.

Move the lever to the **FREE** direction to decrease friction for easy turning.

### R Type (remote control)

Steer the boat in the same manner as an automobile.

# OPERATION

## CRUISING

### Engine Speed

For best fuel economy, limit the throttle opening to 80%. Use the throttle friction control (p. 55 or p. 56 ) to help you hold a steady speed.

For rough water conditions or large waves, slow down to prevent the propeller from rising out of the water.

### Transom Angle

Install the outboard motor at the best transom angle for stable cruising and maximum power.

Transom angle too large: Incorrect causes boat to “squat”.

Transom angle too small: Incorrect causes boat to “bow steer” (Sprayed water may enter the boat).

It is necessary to adjust the transom angle of the outboard motor to compensate for changes in boat load, weight distribution, water conditions, or propeller selection.

Under normal running conditions, the boat will perform best when the antiventilation plate is level with the water surface.

When cruising into a high wind, adjust the outboard motor down slightly to level the boat and improve stability. With a tail wind, adjust the outboard motor up slightly (p. 42 ).

### NOTICE

*Excessive trim/tilt angle during operation can cause propeller ventilation, overheating, and water pump damage. This type of damage is not covered by the Distributor's Limited Warranty (p. 123 ).*

**MOTOR ANGLE  
ADJUSTED TOO  
LOW**

**MOTOR ANGLE  
ADJUSTED TOO  
HIGH**

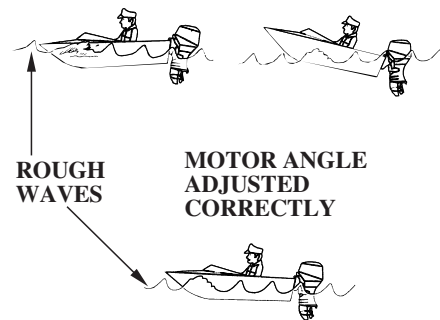

## BOW TOO LOW DUE TO

1. LOAD IN THE FRONT
2. MOTOR ANGLE ADJUSTED TOO LOW

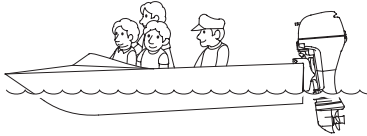

## Motor Angle (Crusing)

O.K.

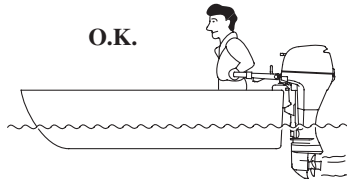

**CORRECT  
GIVES MAXIMUM PERFORMANCE**

## BOW TOO HIGH DUE TO

1. LOAD IN THE REAR
2. MOTOR ANGLE ADJUSTED TOO HIGH

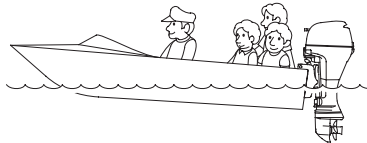

## OPERATION

### SHALLOW WATER OPERATION

#### Manual tilt Type

When operating in shallow water, tilt the outboard motor, using the tilt lever, so the propeller and gear case won't hit the bottom.

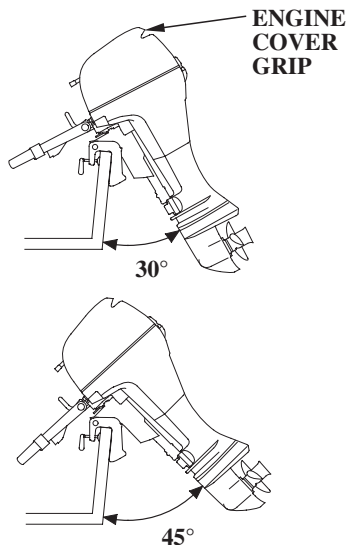

To tilt the outboard motor, move the tilt lever to the TILT position, then raise the outboard motor to the 30° or 45° position by pulling on the engine cover grip.

#### NOTICE

*Do not use the tiller handle as a lever to raise the outboard motor. Applying excessive force to the tiller handle can damage it.*

While the outboard motor is tilted, proceed at a low speed, and do not operate the outboard motor in reverse. The outboard motor will rise suddenly if operated in reverse.

Monitor water flow from the cooling system indicator (p. 31) to be sure the outboard motor is not tilted so high the water intake is out of the water.

#### NOTICE

*An excessive trim/tilt angle during operation can cause propeller ventilation, overheating, and water pump damage. This type of damage is not covered by the Distributor's Limited Warranty (p. 123).*

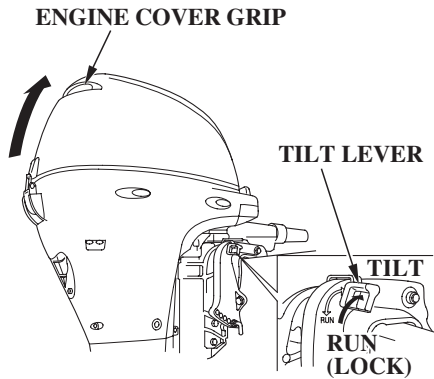

To return the outboard motor to the normal operating position, move the tilt lever to the RUN (LOCK) position, raise the outboard motor slightly to disengage the tilt mechanism, then slowly lower the outboard motor.

## T Type

When operating in shallow water, use the power tilt switch to tilt the outboard motor, so the propeller and gear case won't hit the bottom.

Proceed at low speed, and monitor water flow from the cooling system indicator (p. 31) to be sure the outboard motor is not tilted so high that the water intakes are out of the water.

### NOTICE

*An excessive trim/tilt angle during operation can cause propeller ventilation, overheating, and water pump damage. This type of damage is not covered by the Distributor's Limited Warranty (p. 123).*

## G Type

When operating in shallow water, tilt the outboard motor, using the tilt lever, so the propeller and gear case won't hit the bottom.

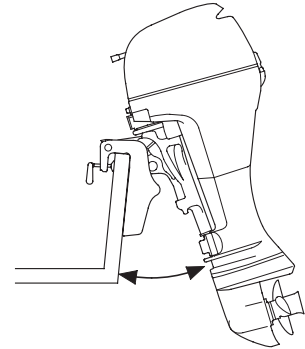

## OPERATION

To tilt the outboard motor, move the tilt lever to the TILT position, then raise the outboard motor to the desired position by pulling on the engine cover grip.

### NOTICE

*Do not use the tiller handle as a lever to raise the outboard motor. Applying excessive force to the tiller handle can damage it.*

While the outboard motor is tilted, proceed at a low speed, and do not operate the outboard motor in reverse. The outboard motor will rise suddenly if operated in reverse.

Monitor water flow from the cooling system indicator (p. 31) to be sure the outboard motor is not tilted so high the water intake is out of the water.

### NOTICE

*An excessive trim/tilt angle during operation can cause propeller ventilation, overheating, and water pump damage. This type of damage is not covered by the Distributor's Limited Warranty (p. 123).*

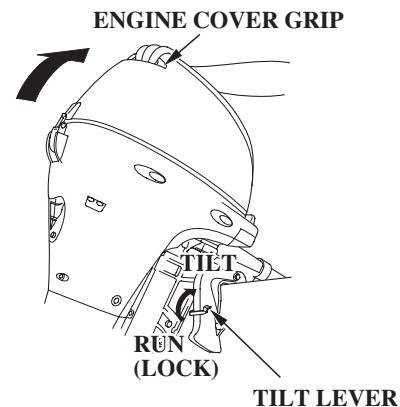

To return the outboard motor to the normal operating position, move the tilt lever to the RUN (LOCK) position, you may need to raise the outboard motor slightly to disengage the tilt mechanism, then slowly lower the outboard motor.



## MOORING, BEACHING, LAUNCHING Manual tilt Type

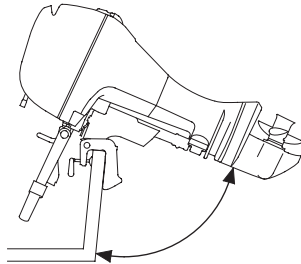

71° or 72° (when mooring)

To raise the outboard motor out of the water while the boat is moored, or for maximum clearance when beaching or launching, tilt the outboard motor to the 71° or 72° position.

Stop the engine before tilting the outboard motor. The 71° or 72° position is not an operating position.

Raise and lower the outboard motor as described on p. 60 .

## G and T Type

To raise the outboard motor out of the water while the engine is stopped and the boat is moored, or for maximum clearance when beaching or launching, use the power tilt switch (T type) to tilt the outboard motor as far as it will go, move the tilt lock lever to the LOCK position, then gently lower the outboard motor until the lever contacts the stern bracket.

If more clearance is needed to swing the tilt lock lever into the LOCK position, rock the outboard motor forward slightly by pulling on the engine cover grip.

To lower the outboard motor, tilt up, move the tilt lock lever to the FREE position, then lower the outboard motor to the desired position.



### NOTICE

*Do not attempt to use the power tilt switch to tilt the outboard motor down while the tilt lock lever is in the lock position. Damage to the power tilt system may occur.*

## OPERATION

---

### T Type

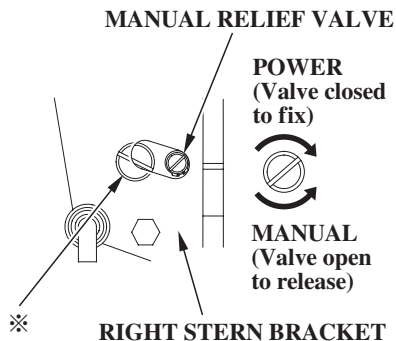

- ※ : Do not turn this screw. If this screw is turned hydraulic oil will bleed out of the power tilt system. Should this happen it will be necessary to contact your closest authorized Honda marine dealer and have the system refilled.

The outboard motor can also be tilted manually after opening the manual relief valve. This feature enables the outboard motor to be tilted when no battery is connected.

For manual tilting, use a flat blade screwdriver to turn the valve counterclockwise 2 and a half turns. Close the valve firmly after positioning the engine.

Be sure the valve is closed before operating the outboard motor. If the valve is not closed, the outboard motor will tilt up when operated in reverse.

# SERVICING YOUR OUTBOARD MOTOR

## THE IMPORTANCE OF MAINTENANCE

Good maintenance is essential for safe, economical, and trouble-free operation. It will also help reduce air pollution.

### **WARNING**

Improperly maintaining this outboard motor, or failure to correct a problem before operation, can cause a malfunction in which you could be seriously hurt or killed.

Always follow the inspection and maintenance recommendations and schedules in this owner's manual.

To help you properly care for your outboard motor, the following pages include a maintenance schedule, routine inspection procedures, and simple maintenance procedures using basic hand tools. Other service tasks that are more difficult, or require special tools, are best handled by professionals and are normally performed by a Honda technician or other qualified mechanic.

The maintenance schedule applies to normal operating conditions. If you operate your outboard motor under unusual conditions, consult an authorized Honda marine dealer for recommendations applicable to your individual needs and use.

Honda will not deny a claim for warranty coverage simply because you did not maintain your outboard. However, any part that fails due to lack of maintenance, or improper maintenance will not be covered under your product warranty.

Remember that your authorized Honda marine dealer knows your outboard motor best and is fully equipped to maintain and repair it.

To ensure the best quality and reliability, use only new, genuine Honda parts or their equivalents for repair and replacement.

**Maintenance, replacement, or repair of the emission control devices and systems may be performed by any marine engine repair establishment or individual, using parts that are “certified” to EPA standards.**

# SERVICING YOUR OUTBOARD MOTOR

---

## MAINTENANCE SAFETY

Some of the most important safety precautions follow. However, we cannot warn you of every conceivable hazard that can arise in performing maintenance. Only you can decide whether or not you should perform a given task.

### **WARNING**

Failure to properly follow maintenance instructions and precautions can cause you to be seriously hurt or killed.

Always follow the procedures and precautions in the owner's manual.

## Safety Precautions

- Make sure the engine is off before you begin any maintenance or repairs. This will eliminate several potential hazards:
  - **Carbon monoxide poisoning from engine exhaust.**  
Be sure there is adequate ventilation whenever you operate the engine.
  - **Burns from hot parts.**  
Let the engine and exhaust system cool before touching.
  - **Injury from moving parts.**  
Do not run the engine unless instructed to do so.
- Read the instructions before you begin, and make sure you have the tools and skills required.
- To reduce the possibility of fire or explosion, be careful when working around gasoline. Use only a nonflammable solvent, not gasoline, to clean parts. Keep cigarettes, sparks, and flames away from all fuel-related parts.
- Wear gloves when handling the propeller to protect your hands from sharp edges.

# SERVICING YOUR OUTBOARD MOTOR

## TOOL KIT AND EMERGENCY STARTER ROPE

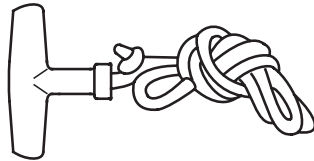

EMERGENCY STARTER ROPE

The following tools are supplied with the outboard motor for simple maintenance procedures and emergency repairs. An emergency starter rope is also supplied. Keep these items on the boat, so they will always be available if you need them.

If your tool kit needs replacement, it is not available as a kit and each item must be ordered individually.

## TOOL KIT



8 mm WRENCH

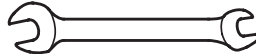

10 × 12 mm WRENCH



PHILIPS SCREWDRIVER



OIL CHECK SCREWDRIVER

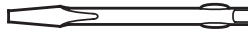

FLAT SCREWDRIVER



SCREWDRIVER GRIP



PLIERS

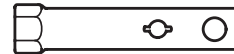

SPARK PLUG WRENCH



10 mm SOCKET WRENCH



SPARE CLIP

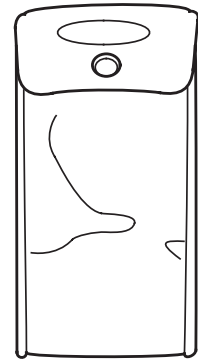

TOOL BAG

# SERVICING YOUR OUTBOARD MOTOR

## MAINTENANCE SCHEDULE

Follow the MAINTENANCE SCHEDULE table and service your outboard motor accordingly. Please note, a claim for warranty coverage will not be denied simply because the maintenance schedule for your outboard was not followed. However, any part(s) that fails specifically due to lack of maintenance, or improperly performed maintenance, would not be covered under the *Distributor's Limited Warranty*.

REGULAR SERVICE PERIOD (3) Perform at every indicated month or operating hour interval, whichever comes first.		Each use	After use	First month or 20 hrs.	Every 6 months or 100 hrs.	Every year or 200 hrs.
ITEM						
Engine oil	Check level	○				
	Change			○	○	
Gear case oil	Change			○	○	
Timing belt	Check					○ (2)
Engine oil filter	Replace					○
Starter rope	Check				○	
Carburetor linkage	Check-adjust			○ (2)	○ (2)	
Idle speed	Check-adjust			○ (2)	○ (2)	
Valve clearance	Check-adjust					○ (2)
Spark plugs	Check-adjust				○	
	Replace					○
Propeller and cotter pin	Check	○				
Lubrication	Grease			○ (1)	○ (1)	
Fuel tank and tank filter	Clean					○

- (1) Lubricate more frequently when used in salt water.
- (2) These items should be serviced by an authorized Honda marine dealer, unless you have the proper tools and are mechanically proficient. Refer to the Honda shop manual for service procedures.
- (3) For professional/commercial use, log hours of operation to determine proper maintenance intervals.

## SERVICING YOUR OUTBOARD MOTOR

REGULAR SERVICE PERIOD (3) Perform at every indicated month or operating hour interval, whichever comes first.		Each use	After use	First month or 20 hrs.	Every 6 months or 100 hrs.	Every year or 200 hrs.
ITEM						
Fuel filter	Check				○	
	Replace					○
Thermostat	Check					○ (2)
Fuel pump line	Check	○				
	Replace		Every 2 years (if necessary) (2)			
Battery and cable connection	Check level-tightness	○				
Bolts and Nuts	Check-tightness			○ (2)	○ (2)	
Crankcase breather tube	Check					○ (2)
Anode	Check	○				
Cooling water passages	Clean		○ (4)			
Water pump	Check					○ (2)

- (1) Lubricate more frequently when used in salt water.
- (2) These items should be serviced by an authorized Honda marine dealer, unless you have the proper tools and are mechanically proficient. Refer to the Honda shop manual for service procedures.
- (3) For professional/commercial use, log hours of operation to determine proper maintenance intervals.
- (4) When operating in salt water, turbid or muddy water, the engine should be flushed with clean water after each use.

# SERVICING YOUR OUTBOARD MOTOR

## MANUAL RELIEF VALVE (T type)

### RIGHT STERN BRACKET

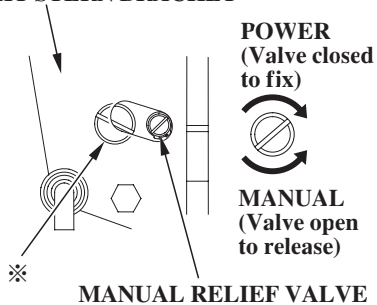

※ : Do not turn this screw. If this screw is turned hydraulic oil will bleed out of the power tilt system. Should this happen it will be necessary to contact your closest authorized Honda marine dealer and have the system refilled.

The outboard motor can be tilted manually after opening the manual relief valve. This feature enables the outboard motor to be tilted when no battery is connected.

For manual tilting, use a flat blade screwdriver to turn the valve counterclockwise 2 and a half turns. Close the valve firmly after positioning the engine.

Be sure the valve is closed before operating the outboard motor. If the valve is not closed, the outboard motor will tilt up when operated in reverse.

## ENGINE COVER REMOVAL AND INSTALLATION

(REAR)

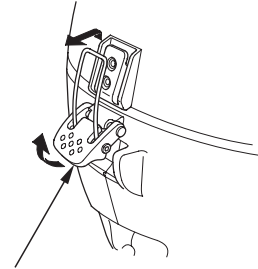

ENGINE COVER LATCH

(FRONT)

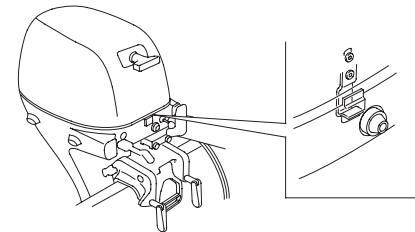



# SERVICING YOUR OUTBOARD MOTOR

## (INSTALLATION)

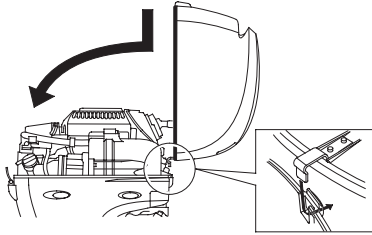

The engine cover latch fastens the engine cover to the outboard motor.

To remove the engine cover, unlatch the engine cover latch, then lift the engine cover off the outboard motor.

To install the engine cover, place the cover on the outboard motor, then latch the engine cover latch securely.

## Engine Oil Level Check

Check the engine oil level with the engine stopped and the outboard motor in the vertical position.

1. Unlatch and remove the engine cover.
2. Remove the dipstick and wipe it clean.

### OIL LEVEL DIPSTICK

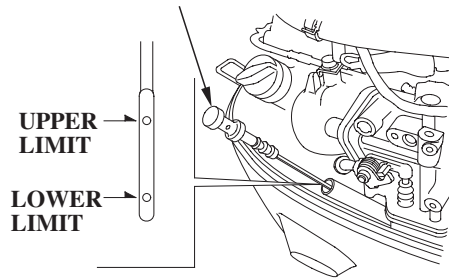

3. Insert the dipstick all the way in, then remove it and check the oil level shown on the dipstick.

### OIL FILLER CAP

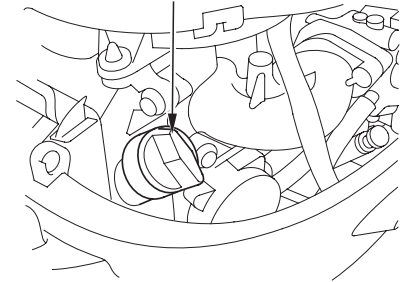

4. If the oil level is low, remove the oil filler cap, and add oil to reach the upper limit mark shown on the dipstick. Use the oil recommended on p. 74 .

### NOTICE

*Running the engine with a low oil level can cause engine damage.*

5. Install the oil filler cap and tighten it securely.
6. Install and lock the engine cover.

# SERVICING YOUR OUTBOARD MOTOR

## Engine Oil Change

An engine oil evacuation device may be used to remove the engine oil.

Drain the used oil while the engine is warm. Warm oil drains quickly and completely.

1. Unlatch and remove the engine cover (p. 70).

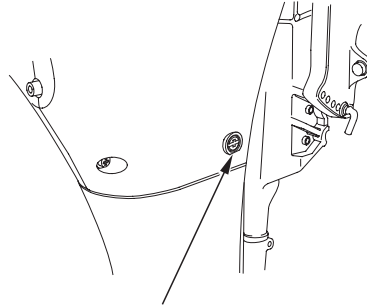

**ENGINE OIL DRAIN SCREW**

2. Remove the oil filler cap, and place a suitable container below the drain screw hole to catch the used oil, then remove the engine oil drain screw.
3. Allow the used oil to drain completely, then reinstall the engine oil drain screw, and tighten it securely.

Inspect the sealing O-ring and replace if damaged or torn.

### NOTICE

*Improper disposal of engine oil can be harmful to the environment. If you change your own oil, please dispose of the used oil properly. Put it in a sealed container, and take it to a recycling center. Do not discard it in a trash bin, dump it on the ground or pour it down a drain.*

4. With the outboard motor in a vertical position, fill to the upper limit mark on the dipstick (p. 71 ) with the recommended oil.

Engine oil refill capacity:

Without oil filter change:

**1.1 US qt (1.0 ℓ)**

With oil filter change:

**1.4 US qt (1.3 ℓ)**

5. Install the oil filler cap and tighten it securely.
6. Install and lock the engine cover.

# SERVICING YOUR OUTBOARD MOTOR

## Oil Filter Change

1. Drain the engine oil, and reinstall the drain screw (see Engine Oil Change on p. 72).
2. Unscrew the six bolts and remove the R. engine under cover.
3. Use a suitable tool to remove the oil filter, and thoroughly drain the filter into the used oil container.

**USE A SUITABLE TOOL**

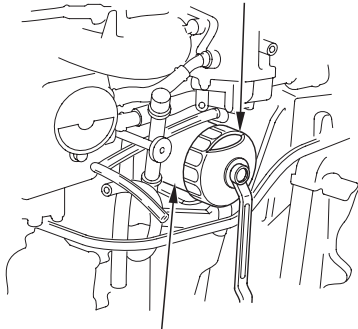

**OIL FILTER**

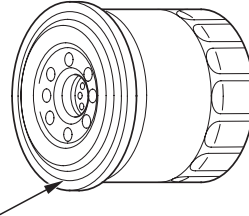

**RUBBER SEAL**

4. Clean the oil filter mounting base, and coat the rubber seal of the new oil filter with clean engine oil.

### **NOTICE**

*Use only a genuine Honda oil filter or a filter of equivalent quality specified for your model. Using the wrong filter, or a non-Honda filter which is not of equivalent quality, may cause engine damage.*

5. Screw on the new filter by hand until it contacts the engine, then use a suitable tool to tighten the filter an additional  $7/8$  turn.

**OIL FILTER TIGHTENING TORQUE:**  
**9 lbf-ft (12 N·m , 1.2 kgf·m)**

6. Fill the crankcase with the specified amount (p. 72) of the recommended oil.
7. Start the engine and check for leaks.

### **NOTICE**

*Running the engine without water can cause serious engine damage. If you are changing the oil filter while the outboard motor is out of the water, place unit in water or supply adequate water to the water intakes before running the engine.  
Do not run engine with flush attachment on power head.*

8. Stop the engine, and check the oil level as described on page 71. If necessary, add oil to bring the oil level to the upper limit mark on the dipstick.

# SERVICING YOUR OUTBOARD MOTOR

## Engine Oil Recommendations

Oil is a major factor affecting performance and service life. Use 4-stroke automotive detergent oil.

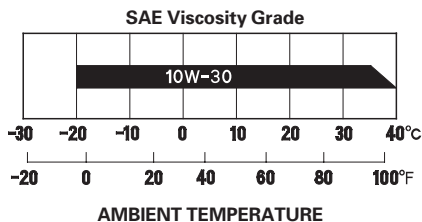

SAE 10W-30 is recommended for general use.

The SAE oil viscosity and service classification are in the API label on the oil container. Honda recommends that you use API SERVICE category SG, SH, SJ or SL oil with the “starburst” certification mark displayed on the container.

## Gear Oil Level Check

Check the gear oil level with the engine stopped and the outboard motor in the vertical position.

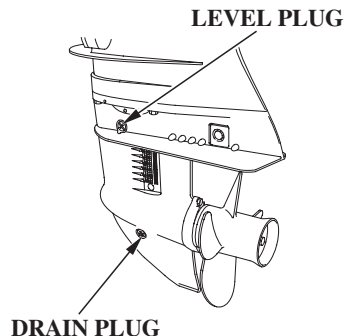

Remove the oil level plug and see whether oil flows from the oil level hole.

If oil flows from the oil level hole, the oil level is OK. Reinstall the plug and tighten it securely.

**OIL LEVEL PLUG TORQUE:**  
4.8 lbf·ft (6.5 N·m , 0.66 kgf·m)

## SERVICING YOUR OUTBOARD MOTOR

If no oil flows from the oil level hole, add the recommended oil (p. 76) following the procedure described in Gear Oil Change.

### Gear Oil Change

Change the gear oil with the engine stopped and the outboard motor in the vertical position.

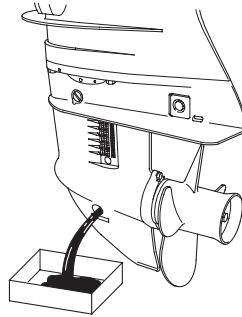

1. Place a suitable container below the oil drain hole to catch the used oil, then remove the oil level plug and oil drain plug.

2. Allow the used oil to drain completely, then install an oil pump adapter in the oil drain hole.

If water or contaminated (milky-colored) oil flows out the drain hole when the plug is removed, have the outboard motor checked by an authorized Honda marine dealer.

## SERVICING YOUR OUTBOARD MOTOR

---

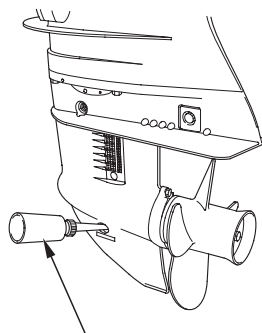

**GEAR OIL BOTTLE**

3. Add oil through the oil drain hole until it flows out the oil level hole, then install the oil level plug and the oil drain plug.

**GEAR OIL CAPACITY:**  
0.301 US qt (0.285 ℓ)

Outboard motor SAE 90 hypoid  
gear oil API Service classification  
(GL-4 or GL-5)

**OIL LEVEL PLUG TORQUE:**  
4.8 lbf·ft (6.5 N·m , 0.66 kgf·m)

Avoid losing more than 1 fl oz (30 cm<sup>3</sup>) while reinstalling the drain plug.

**OIL DRAIN PLUG TORQUE:**  
4.8 lbf·ft (6.5 N·m , 0.66 kgf·m)

# SERVICING YOUR OUTBOARD MOTOR

## Lubrication Points

Apply marine waterproof grease to the following parts:  
Lubrication interval:  
20 operating hours or one month after the date of purchase or the initial use, then every 100 hours or 6 months.

### NOTICE

*To prevent corrosion, apply anticorrosion oil to pivot surfaces where grease cannot penetrate.*

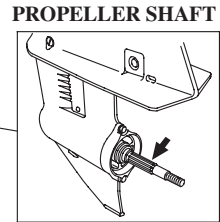
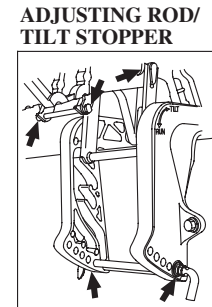
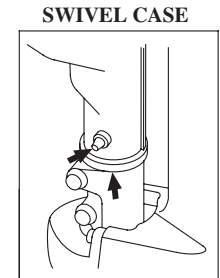
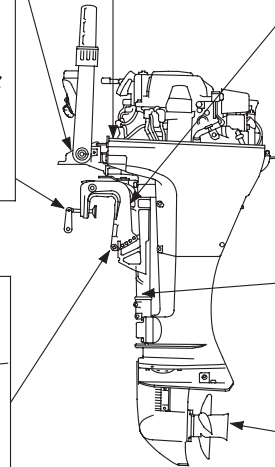
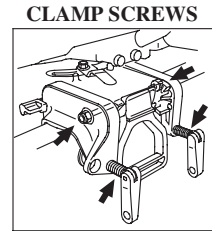
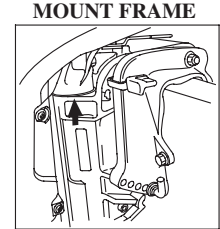
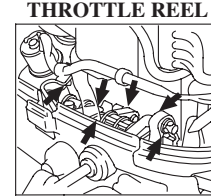
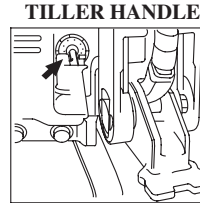
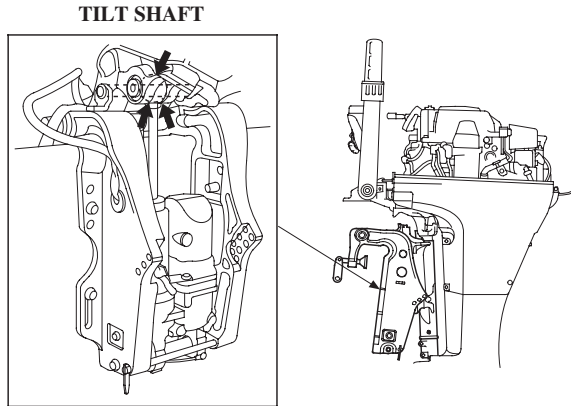

Apply Honda Marine Corrosion Inhibitor (or equivalent) to all areas under the engine cover and any exposed metal surfaces except the belts.

# SERVICING YOUR OUTBOARD MOTOR

## Spark Plug Service

RECOMMENDED SPARK PLUGS:  
CR5EH-9 (NGK)  
U16FER9 (DENSO)

### NOTICE

*Incorrect spark plugs can cause engine damage.*

1. Unlatch and remove the engine cover (p. 70).
2. Disconnect the spark plug caps from the spark plugs.
3. Remove the spark plugs with a spark plug wrench.

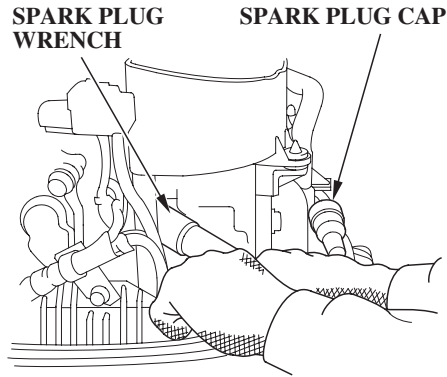

4. Inspect the spark plugs. Replace them if the electrodes are worn, or if the insulators are cracked or chipped.

### SIDE ELECTRODE

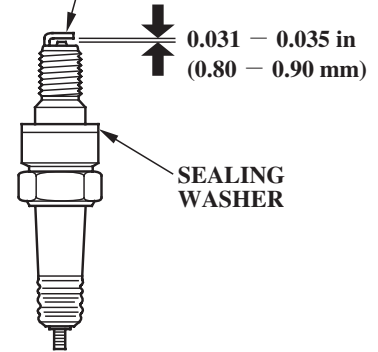

5. Measure the spark plug electrode gap with a wire-type feeler gauge. Correct the gap, if necessary, by carefully bending the side electrode.

The gap should be:  
0.031 - 0.035 in (0.80 - 0.90 mm)



# SERVICING YOUR OUTBOARD MOTOR

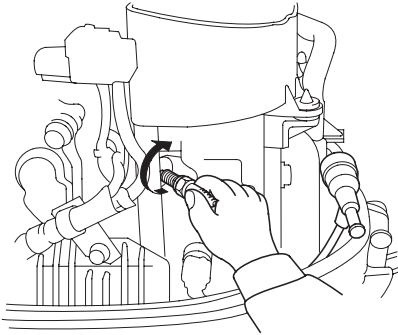

6. Install the spark plugs carefully, by hand, to avoid cross-threading.

7. After each spark plug seats, tighten with a spark plug wrench supplied in the tool kit to compress the sealing washer.

If reinstalling the used spark plug, tighten  $1/8 - 1/4$  turn after the spark plug seats.

If installing new spark plugs, tighten  $1/2$  turn after the spark plug seats.

## NOTICE

*Loose spark plugs can overheat and damage the engine.  
Overtightening the spark plugs can damage the threads in the cylinder head.*

8. Attach the spark plug caps.

9. Install and lock the engine cover.

## REFUELING

### Portable Fuel Tank

FUEL TANK CAPACITY:  
3.2 US gal (12 l)

Check the fuel gauge and refill the tank when necessary.

Remove the fuel tank from the boat for refueling.

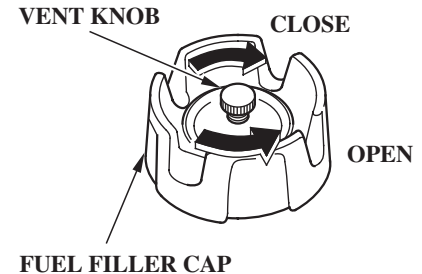

To refuel, turn the vent knob counterclockwise to the OPEN position, and unscrew the fuel filler cap.

# SERVICING YOUR OUTBOARD MOTOR

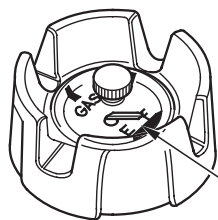

FUEL GAUGE

SAFE FILL LEVEL

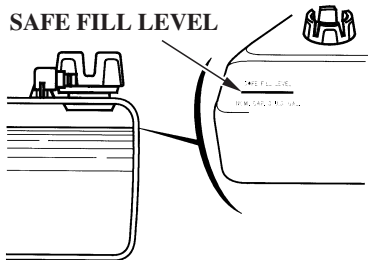

Refuel in a well-ventilated area. Fill the tank to the SAFE FILL LEVEL line.

After refueling, install the cap and tighten it securely. Turn the vent knob clockwise to the CLOSED position, and return the fuel tank to the boat.

## ⚠ WARNING

Gasoline is highly flammable and explosive.

You can be burned or seriously injured when handling fuel.

- Stop the engine and keep heat, sparks, and flame away.
- Handle fuel only outdoors.
- Wipe up spills immediately.

Never refill the fuel tank inside a building where gasoline fumes may reach flames or sparks. Keep gasoline away from appliance pilot lights, barbecues, electric appliances, power tools, etc.

Spilled fuel is not only a fire hazard, it causes environmental damage. Wipe up spills immediately.

## FUEL RECOMMENDATIONS

Use unleaded gasoline with a pump octane rating of 86 or higher.

Your outboard motor is certified to operate on unleaded gasoline. Unleaded gasoline produces fewer engine and spark plug deposits and extends exhaust system life.

Never use stale or contaminated gasoline or an oil/gasoline mixture. Avoid getting dirt or water in the fuel tank.

Occasionally you may hear a light “spark knock” or “pinging” (metallic rapping noise) while operating under heavy loads. This is no cause for concern.

If spark knock or pinging occurs at a steady engine speed, under normal load, change brands of gasoline. If spark knock or pinging persists, see an authorized Honda marine dealer.

## NOTICE

*Running the engine with persistent spark knock or pinging can cause engine damage.*

Running the engine with persistent spark knock or pinging is misuse, and the *Distributor's Limited Warranty* (p. 123 ) does not cover parts damaged by misuse.

For information regarding oxygenated fuels, please refer to page 107.

## Fuel Filter Inspection and Replacement

The fuel filter is located under the engine cover, on the right side of the engine.

Water or sediment accumulated in the filter can cause loss of power or hard starting. To prevent engine malfunction, inspect the filter and replace when necessary.

## WARNING

Gasoline is highly flammable and explosive.

You can be burned or seriously injured when handling fuel.

- Stop the engine and keep heat, sparks, and flame away.
- Handle fuel only outdoors.
- Wipe up spills immediately.

# SERVICING YOUR OUTBOARD MOTOR

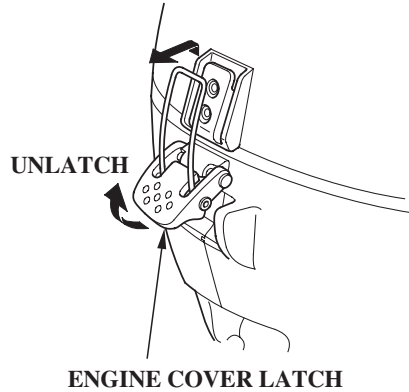

1. Unlatch and remove the engine cover for access to the fuel pump filter.

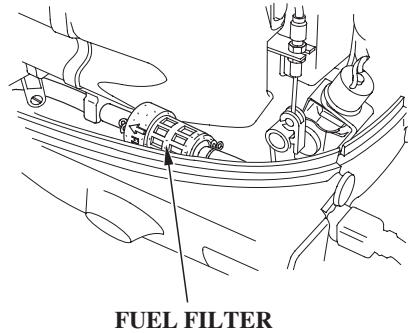

2. Inspect the filter for water and/or sediment accumulation.

If the filter is OK, reinstall it. If water and/or sediment are present, replace the filter as described in the following steps. Always replace the filter at the scheduled replacement interval (p. 69 ).

3. Disconnect the fuel hose connector from the outboard motor, and place clamps on the fuel hoses on each side of the filter to prevent fuel leakage when the fuel hoses are disconnected.

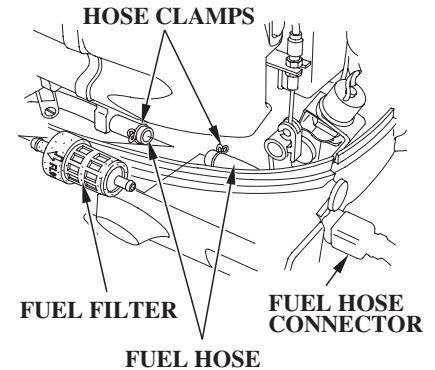

4. Remove the fuel hoses from the used filter, and discard the filter.

To ease hose removal, release the hose clamps by squeezing the clip ends together with pliers while pulling off the hoses.

# SERVICING YOUR OUTBOARD MOTOR

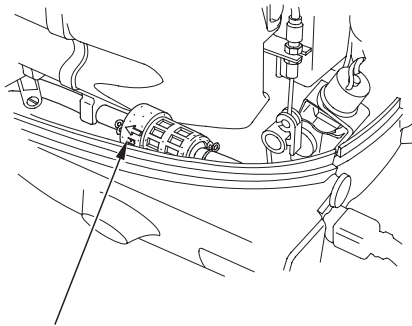

**ARROW**  
(Fuel Flow Direction)

5. Install the new filter on the fuel hoses, with the fuel flow arrow pointing toward the fuel pump as shown. Fuel flow will be impeded if the filter is installed backward.
6. Remove the fuel hose clamps, and connect the fuel hose to the outboard motor. Check for leaks.
7. Install and lock the engine cover.

## Portable Fuel Tank and Filter Cleaning

### **⚠ WARNING**

Gasoline is highly flammable and explosive.

You can be burned or seriously injured when handling fuel.

- Stop the engine and keep heat, sparks, and flame away.
- Handle fuel only outdoors.
- Wipe up spills immediately.

## *Fuel Tank*

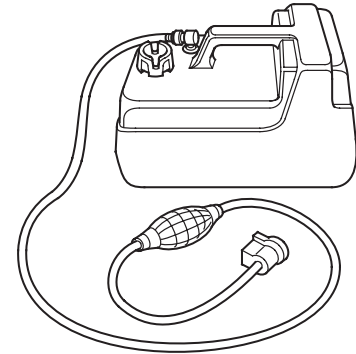

Empty the portable fuel tank into an approved gasoline container. Use a funnel to avoid spilling fuel. Rinse the fuel tank with nonflammable solvent to remove any accumulated sediment.

# SERVICING YOUR OUTBOARD MOTOR

## Fuel Tank Filter

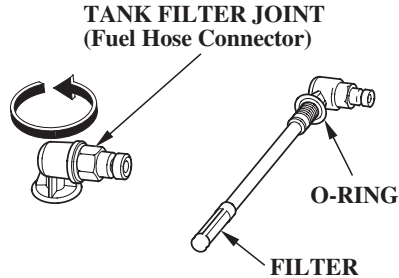

1. Unscrew the fuel hose connector by turning it counterclockwise, then remove the fuel hose connector and fuel filter from the tank.
2. Clean the filter in nonflammable solvent. Inspect the fuel tank filter and the connector O-ring. Replace them if damaged.
3. Reinstall the filter and hose connector in the fuel tank. Tighten the hose connector securely.

## Recoil Starter Rope Inspection

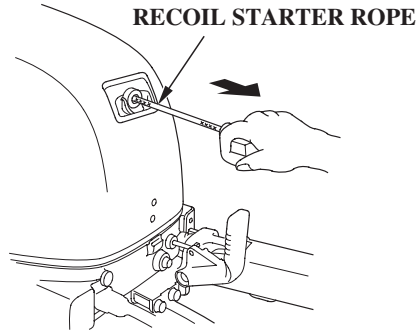

Inspect the recoil starter rope, and replace it if it becomes frayed.

Always keep the emergency starter rope on the boat in case the recoil starter rope fails.

## Anode Replacement

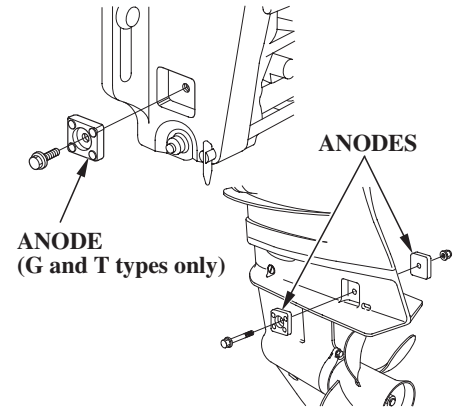

The anodes are located on each side of the gearcase and the stern bracket (G and T type). They are made of a sacrificial material that helps to protect the outboard motor from corrosion.

Replace the anodes when they have been reduced to about half their original size, or if they are crumbling.

# SERVICING YOUR OUTBOARD MOTOR

## NOTICE

*Painting or coating the anodes will defeat their purpose and will lead to rust and corrosion damage to the outboard motor. The anodes must be exposed to the water in order to protect the outboard motor.*

## Choke Knob Friction (manual choke type)

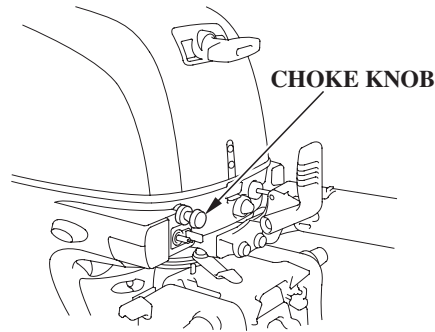

If the choke knob returns to the OFF position by itself, you can adjust the friction that holds the knob in the ON position.

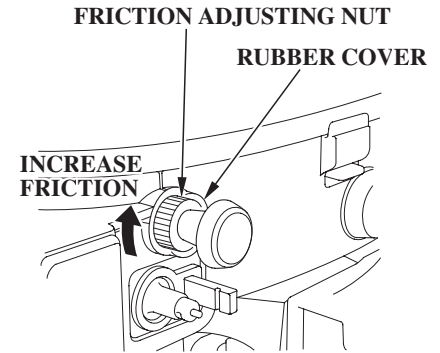

To adjust the friction, squeeze the rubber cover to grip the adjusting nut and turn it clockwise to increase the friction. Do not force the adjusting nut. If it is too hard to turn by hand, contact your Honda Marine dealer for assistance.

# SERVICING YOUR OUTBOARD MOTOR

## Propeller Replacement

Before replacing the propeller, remove the clip from the engine stop switch to prevent any possibility of the engine being started while you are working with the propeller.

The propeller blades may have sharp edges, so wear heavy gloves to protect your hands.

Operating the outboard motor at higher altitudes will reduce available power. This may require decreasing the propeller pitch to maintain correct engine RPM.

### Removal

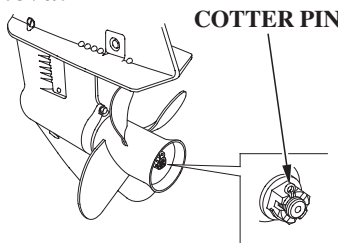

Remove the cotter pin, unscrew the castle nut, remove the washer, then remove the propeller and thrust washer.

### Installation

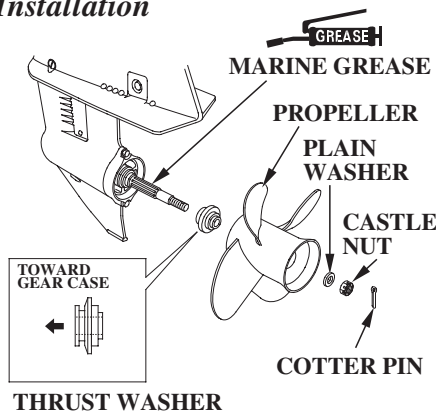

Install the propeller in the reverse order of removal.

- Install the thrust washer with the grooved side toward the gear case.
- Tighten the castle nut with your hand first until the propeller has no play. Then, tighten the castle nut again with a tool until the groove in the castle nut aligns with the cotter pin hole. (Note that this tool is not included in the tools that come together with the outboard motor. For tools, please contact your closest authorized Honda marine dealer.)
- Use a genuine Honda stainless steel cotter pin or equivalent cotter pin and bend the pin ends as shown.

**CASTLE NUT  
TIGHTENING TORQUE:**  
0.74 lbf-ft (1 N·m, 0.1 kgf·m)  
**UPPER LIMIT OF TORQUE:**  
25 lbf-ft (34 N·m, 3.5 kgf·m)



## STORAGE PREPARATION

Proper storage preparation is essential for keeping your outboard motor trouble-free and looking good. The following steps will help to keep rust and corrosion from impairing your outboard motor's function and appearance, and will make the engine easier to start when you use the outboard motor again.

### Cleaning and Flushing

Thoroughly clean and flush the outboard motor with fresh water after operation in dirty water or salt water.

Touch up any damaged paint, and coat areas that may rust with Honda Corrosion Inhibitor, or equivalent. Lubricate controls with a silicone spray lubricant.

### Cleaning

Wash the outside of the outboard motor with clean, fresh water to

remove mud, salt, seaweed, etc.

Disengage the switch clip from the engine stop switch (H type) or emergency stop switch (R type), and pull the recoil starter rope several times to expel any water remaining in the water pump.

### *Flushing With the Honda Garden Hose Adapter (optional equipment)*

1. Unlatch the engine cover latch and remove the engine cover (p. 70 ), and install the garden hose adapter.
2. Attach a garden hose from a fresh water faucet to the garden hose adapter.
3. Turn on the fresh water supply, and verify that there is good water pressure at the outboard motor.
4. Flush the engine with fresh water for at least 10 minutes.

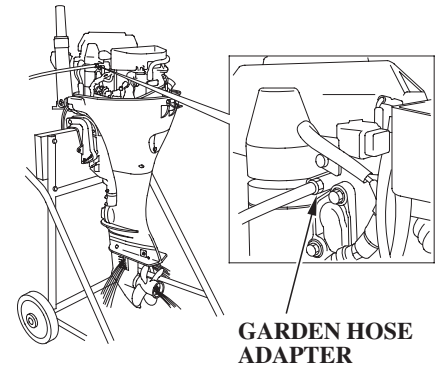

Do not run the engine.

After flushing, remove the garden hose adapter, reinstall the engine cover.

## STORAGE

### *Flushing Without the Honda Garden Hose Adapter*

It is necessary to run the engine during the flushing procedure. For safety, remove the propeller from the outboard motor (p. 86 ).

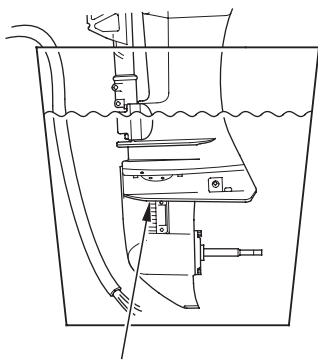

**ANTIVENTILATION PLATE**

1. Place a container under the outboard motor, and fill it with clean, fresh water. The water level must be at least 2 inches above the antiventilation plate.

#### **NOTICE**

*Running the engine without good water circulation can cause overheating and water pump damage.*

Damage caused by running the outboard motor without sufficient cooling water is not covered by the *Distributor's Limited Warranty* (p. 123 ).

2. Start the engine and run in the N (neutral) position at low speed for at least 10 minutes.
3. After flushing, stop the engine, remove the water container, and reinstall the propeller (p. 86 ).

### **Fuel**

#### **NOTICE**

*Depending on the region where you operate your outboard, fuel formulations may deteriorate and oxidize rapidly. Fuel deterioration and oxidation can occur in as little as 15 days and may cause damage to the carburetors and fuel system. Please check with your servicing dealer for local storage recommendations.*

Gasoline will oxidize and deteriorate in storage. Old gasoline will cause hard starting, and it leaves gum deposits that clog the fuel system. If the gasoline in your fuel tank and carburetor deteriorates during storage, you may need to have the carburetor and other fuel system components serviced or replaced.

The length of time that gasoline can be left in your fuel tank and carburetor without causing functional problems will vary with such factors as gasoline blend, your storage temperatures, and whether the fuel tank is partially or completely filled. The air in a partially filled fuel tank promotes fuel deterioration. Very warm storage temperatures accelerate fuel deterioration. Fuel deterioration problems may occur in less than 30 days, if the gasoline was not fresh when you filled the fuel tank.

You can extend fuel storage life by adding a gasoline stabilizer that is formulated for that purpose, or you can avoid fuel deterioration problems by draining all the fuel from the fuel tank and carburetor.

### ***Adding a Fuel Stabilizer***

When adding a fuel stabilizer, fill the fuel tank with fresh gasoline. If only partially filled, air in the tank will promote fuel deterioration during storage. If you keep an additional container of gasoline for refueling, be sure that it contains only fresh gasoline.

1. Add fuel stabilizer following the manufacturer's instructions.
2. After adding a fuel stabilizer, run the engine in water for 10 minutes to be sure that the treated gasoline has replaced the untreated gasoline in the carburetor.
3. Turn the engine OFF.

The *Distributor's Limited Warranty* (p. 123) does not cover fuel system damage or engine performance problems resulting from neglected storage preparation.

### ***Draining the Fuel System***

You can avoid fuel deterioration problems by draining the fuel tank and carburetors.

1. Disconnect the fuel hose from the outboard motor.

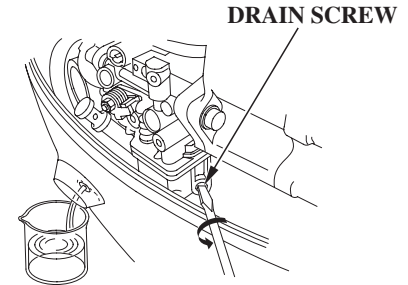

## STORAGE

---

2. With the outboard motor in a vertical position, place an approved gasoline container below the fuel drain outlet, and use a funnel to avoid spilling fuel. Loosen the drain screw to drain fuel from the carburetor.

### **WARNING**

Gasoline is highly flammable and explosive.

You can be burned or seriously injured when handling fuel.

- Stop the engine and keep heat, sparks, and flame away.
- Handle fuel only outdoors.
- Wipe up spills immediately.

3. After the fuel has drained from the carburetor, tighten the drain screw securely.
4. Drain the portable fuel tank into an approved gasoline container, or if you need to store fuel in the fuel tank, you can extend fuel storage life by filling the fuel tank with fresh gasoline and adding a fuel stabilizer that is formulated for that purpose. Firmly close the fuel cap vent knob.

Store the portable fuel tank in a cool place.

## Engine Oil

1. Change the engine oil and the oil filter (p. 72 — 73).
2. Remove the spark plugs (p. 78 ), and remove the clip from the engine stop switch (H type) or emergency stop switch (R type).
3. Pour a tablespoon (5 — 10 cm<sup>3</sup>) of clean engine oil into each cylinder.
4. Pull the starter rope several times to distribute the oil in the cylinders.
5. Reinstall the spark plugs (p. 79 ).

## STORAGE PRECAUTIONS

Select a well-ventilated storage area. If possible, avoid storage areas with high humidity.

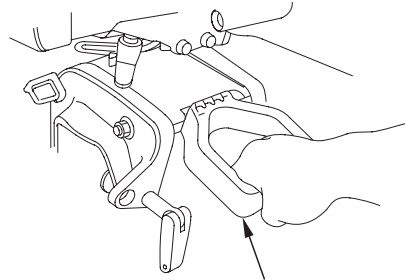

CARRYING HANDLE

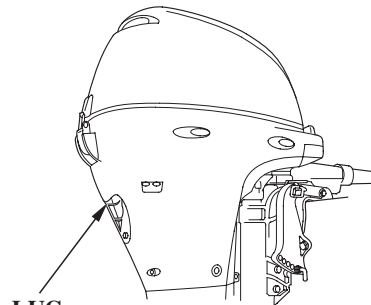

LUG

To carry the outboard motor, hold it by the carrying handle, or hold by the carrying handle and the lug beneath the engine cover latch, as shown.

### NOTICE

*Lifting the outboard motor by the engine cover, or using the installed outboard motor as a handle or lever to move the boat, can damage the outboard motor.*

If your portable fuel tank contains gasoline, store it away from any appliance that operates with a flame, such as a furnace, water heater, or clothes dryer. Also avoid any area with a spark-producing electric motor, or where power tools are operated.

## STORAGE

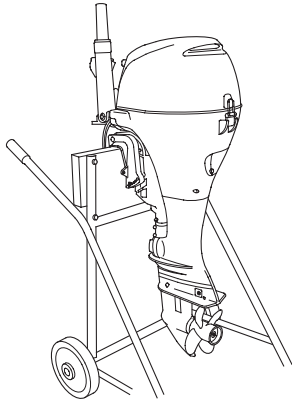

Store the outboard motor either vertically or horizontally with the tiller handle side up.

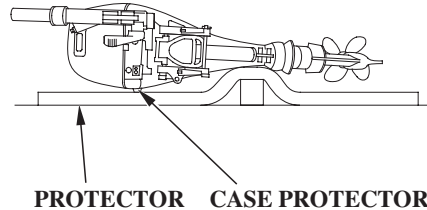

If it is necessary to store the outboard horizontally, drain the carburetor (p. 89 ) and drain the engine oil (p. 72 ), before removing the outboard motor from the boat.

Fold the tiller handle, and rest the outboard motor on its case protectors. Be sure all water has drained from the outboard motor before placing it on its side, so no residual water can enter the engine exhaust port.

### NOTICE

*Any other horizontal storage position may cause damage or oil leakage.*

Cover the outboard motor to keep out dust. Do not use sheet plastic as a dust cover. A nonporous cover will trap moisture, promoting rust and corrosion.

### REMOVAL FROM STORAGE

Check your outboard motor as described in the *BEFORE OPERATION* chapter of this manual.

If the cylinders were coated with oil during storage preparation, the engine may smoke briefly at startup. This is normal.

# TRANSPORTING

## WITH OUTBOARD MOTOR INSTALLED ON BOAT

When trailering a boat with the outboard motor attached, leave the engine in the normal running position, if possible, and tighten the steering friction lever securely (p. 57).

If there is insufficient road clearance in the normal running position, then tilt the outboard motor and use a motor support bar, or remove the outboard motor from the boat. Refer to the manufacturer's instructions for using a motor support bar.

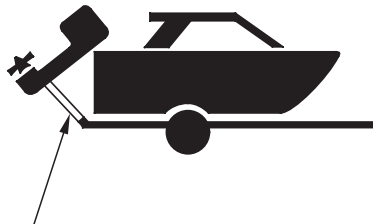

**MOTOR SUPPORT BAR**  
(commercially available)

## WITH OUTBOARD MOTOR REMOVED FROM BOAT

Secure the outboard motor in either the vertical or horizontal position shown on p. 92.

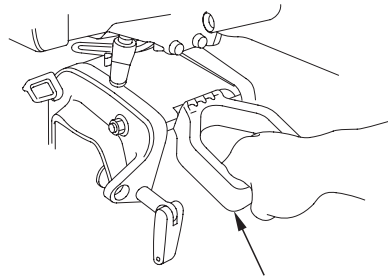

**CARRYING HANDLE**

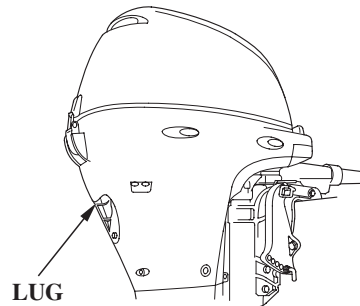

**LUG**

To carry, hold the outboard motor by the carrying handle, or hold by the carrying handle and the lug beneath engine cover lock lever, as shown.

### NOTICE

*Lifting the outboard motor by the engine cover, or using the installed outboard motor as a handle or lever to move the boat, can damage the outboard motor.*

## TAKING CARE OF UNEXPECTED PROBLEMS

ELECTRIC STARTER WILL NOT OPERATE	Possible Cause	Correction
1. Check battery (electric start type).	Battery connections loose or corroded.	Clean and tighten battery connections.
	Battery discharged.	Recharge battery.
2. Check fuse.	Fuse burnt out.	Replace fuse (p. 99 ).
3. Use emergency starting procedure (p. 50 ), then take outboard motor to an authorized Honda marine dealer, or refer to the shop manual.	Starter malfunction, switch malfunction, or electrical problem in the starting circuit.	Replace or repair faulty components as necessary.



## TAKING CARE OF UNEXPECTED PROBLEMS

---

ENGINE WILL NOT START	Possible Cause	Correction
1. Check engine stop switch clip or emergency stop switch clip.	Clip not inserted in stop switch.	Insert clip in stop switch.
2. Check control positions.	Gearshift lever or control lever not in neutral position.	Shift to neutral (p. 46 or p. 48).
	Choke OFF (tiller handle and manual choke type).	Pull choke knob to ON position, unless engine is warm (p. 46).
	Throttle grip not in START position (tiller handle type).	Turn throttle grip to START position (p. 46).
	Fast idle lever raised (remote control/side-mount type).	Leave fast idle lever OFF, if the engine is warm (p. 49).

## TAKING CARE OF UNEXPECTED PROBLEMS

---

ENGINE WILL NOT START (continued)	Possible Cause	Correction
3. Check fuel.	Out of fuel.	Refuel (p. 79 ).
	Fuel vent closed (portable fuel tank).	Open fuel filler cap vent (p. 44 ).
	Fuel hose not primed.	Squeeze priming bulb (p. 45 ).
	Fuel filter or fuel tank filter clogged.	Replace fuel filters (p. 81 or 84 ).
	Bad fuel; boat stored without treating or draining gasoline, or refueled with bad gasoline.	Drain fuel tank and carburetors (p. 89 ). Refill with fresh gasoline (p. 79 ).
4. Remove and inspect spark plugs.	Spark plugs faulty, fouled or improperly gapped.	Gap or replace spark plugs (p. 78 ).
	Spark plugs wet with fuel (flooded engine).	Dry and reinstall spark plugs. Start engine with choke and throttle open.
5. Take outboard motor to an authorized Honda marine dealer, or refer to the shop manual.	Carburetor malfunction, fuel pump failure, ignition malfunction, stuck valves, etc.	Replace or repair faulty components as necessary.

## TAKING CARE OF UNEXPECTED PROBLEMS

HARD STARTING OR STALLS AFTER STARTING	Possible Cause	Correction
1. Check control positions.	Choke OFF (tiller handle and manual choke type).	Pull choke knob to ON position, unless engine is warm (p. 46).
	Throttle grip not in START position (tiller handle type).	Turn throttle grip to START position (p. 46).
	Fast idle lever raised (remote control/side-mount type).	Leave fast idle lever OFF, unless engine is warm (p. 49).
2. Check fuel.	Fuel vent closed (portable fuel tank).	Open fuel filler cap vent (p. 44).
	Fuel hose not primed.	Squeeze priming bulb (p. 45).
	Fuel filter or fuel tank filter clogged.	Replace fuel filters (p. 81 or 84).
	Bad fuel; boat stored without treating or draining gasoline, or refueled with bad fuel.	Drain fuel tank and carburetors (p. 89). Refill with fresh gasoline (p. 79).

## TAKING CARE OF UNEXPECTED PROBLEMS

---

HARD STARTING OR STALLS AFTER STARTING (continued)	Possible Cause	Correction
3. Remove and inspect spark plugs.	Spark plugs faulty, fouled or improperly gapped.	Gap or replace spark plugs (p. 78 ).
4. Take outboard motor to an authorized Honda marine dealer, or refer to the shop manual.	Carburetor malfunction, fuel pump failure, ignition malfunction, etc.	Replace or repair faulty components as necessary.

ENGINE OVERHEATS	Possible Cause	Correction
1. Check water intake screens.	Water intake screens clogged.	Clean water intake screens.
2. Take outboard motor to an authorized Honda marine dealer, or refer to the shop manual.	Faulty thermostat or water pump.	Replace or repair faulty components as necessary.

## TAKING CARE OF UNEXPECTED PROBLEMS

### BATTERY WILL NOT CHARGE AND ELECTRIC STARTER WILL NOT OPERATE

The battery-charging circuit and the electric starter relay circuit are protected by the 20-ampere fuse. If the fuse burns out, the engine will not charge the battery, and the electric starter will not operate. The engine can be started using the recoil starter or the emergency starter rope.

The ignition switch is protected by the 20-ampere fuse. If the fuse burns out, the engine will not start or run, and the power tilt switch will not operate.

### Fuse Replacement

1. With the engine stopped, remove the engine cover.
2. Remove the fuse case lid.

3. Remove and inspect the fuse. If burnt out, install a replacement fuse of the specified rating. The outboard motor only comes with one spare fuse in the fuse holder.

DESIGNATED FUSE: 20A

#### NOTICE

*Never use a fuse with a rating greater than specified. Serious damage to the electrical system could result.*

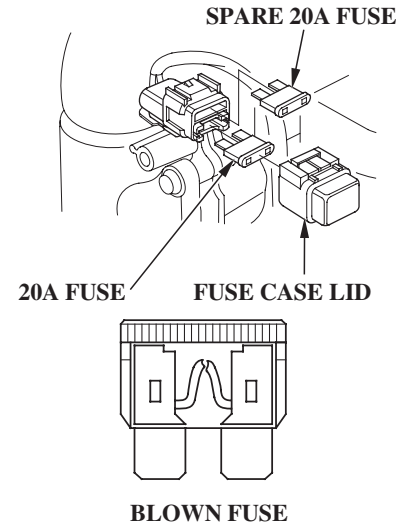

4. Reinstall the fuse case lid and the engine cover.

Before further operation, try to determine and correct the electrical problem that caused the fuse to burn out. An uncorrected electrical problem may cause the fuse to burn out again.

## TAKING CARE OF UNEXPECTED PROBLEMS

### OIL PRESSURE INDICATOR LIGHT GOES OFF AND ENGINE SPEED IS LIMITED

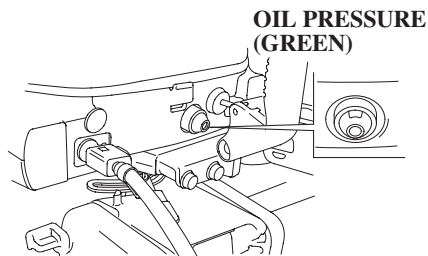

(tiller handle type)

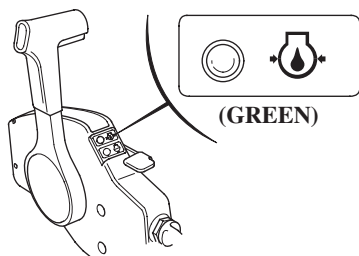

(remote control type)

If oil pressure becomes low, the green indicator light will go off, and the engine protection system will limit engine speed. If you are at cruising speed, engine speed will decrease automatically.

When normal oil pressure is restored, the engine speed will gradually rise to normal engine speed.

Remote control types are equipped with a buzzer that sounds continuously when the green indicator light goes off. The buzzer sound stops below an engine speed of 1,400 rpm.

Low oil pressure may be the result of a low engine oil level, or there may be a problem with the engine lubrication system.

If the throttle is closed suddenly after full throttle operation, engine speed may drop below the specified idle rpm, and that could activate the engine protection system momentarily.

If low oil pressure activates the engine protection system, stop the engine, check the engine oil level (p. 71), and add oil if needed.

With the engine oil at the recommended level, restart the engine. If the lubrication system is OK, the green indicator light should come on within 30 seconds, and the engine will respond normally to throttle grip or control lever operation.

If the engine protection system remains activated after 30 seconds, return to the nearest boat landing, and have the outboard motor inspected by an authorized Honda marine dealer.

## TAKING CARE OF UNEXPECTED PROBLEMS

### OVERHEAT AND ENGINE SPEED IS LIMITED

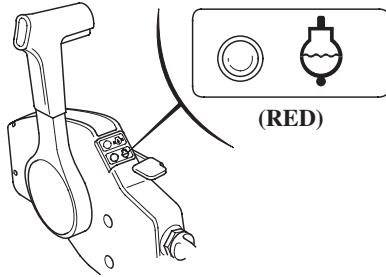

#### (R type)

If the engine overheats, the red indicator light will come on and the buzzer will sound a continuous tone as the engine speed is reduced to 1,800 rpm. If the condition persists for another 20 seconds, the engine will shut off.

#### (H type)

If the engine overheats, the engine speed will be reduced to 1,800 rpm. If the condition persists for another 20 seconds, the engine will shut off.

#### (all types)

If you are at cruising speed when the overheat protection system is activated, the engine speed will decrease automatically. When normal engine temperature is restored, the engine speed will gradually rise to normal engine speed.

Engine overheating may be the result of restricted water intake screens, or there may be a problem with the cooling system thermostat or water pump.

If the engine is stopped after running at full throttle, and then restarted soon afterward, that could activate the engine protection system momentarily.

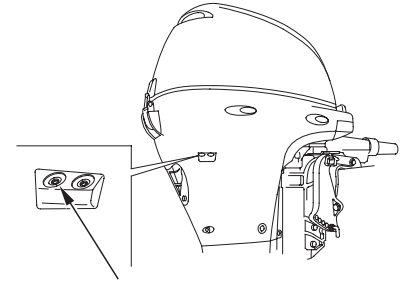

**COOLING SYSTEM INDICATOR**

If overheating activates the engine protection system, idle the engine in neutral, and check the cooling system indicator.

## TAKING CARE OF UNEXPECTED PROBLEMS

---

If water is flowing from the cooling system indicator, continue idling for 30 seconds. If the cooling system is OK, the red indicator light should go off within 30 seconds (R types), and the engine will respond normally to throttle grip or control lever operation.

If there is no water flowing from the cooling system indicator, stop the engine, and tilt the outboard motor to inspect the water intake screens. If clogged, clean the water intake screens, return the outboard motor to the running position, restart the engine, and check the cooling system indicator again.

If there is still no water flowing from the cooling system indicator, or if the engine protection system remains activated after 30 seconds, return to the nearest boat landing, and have the outboard motor inspected by an authorized Honda marine dealer.



## TAKING CARE OF UNEXPECTED PROBLEMS

### SUBMERGED MOTOR

A submerged outboard motor must be serviced immediately after it is recovered from the water in order to minimize corrosion.

If there is a Honda marine dealer nearby, take the motor to the dealer immediately. If you are far from a dealer, proceed as follows:

1. Remove the engine cover, and rinse the outboard motor with fresh water to remove salt water, sand, mud, etc.
2. Drain the carburetor as described on p. 89 .

3. Change the engine oil and oil filter as described on p. 72 – 73 . If there was water in the engine crankcase, or if the used engine oil showed signs of water contamination, then a second engine oil change should be performed after running the engine for half an hour.

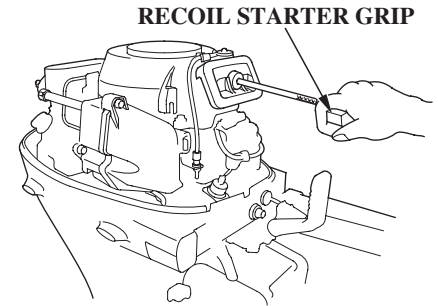

4. Remove the spark plugs (p. 78 ), and remove the clip from the emergency stop switch or engine stop switch. Pull the recoil starter grip, rotate the flywheel a few revolutions to completely expel any water from the cylinders.

If the engine was running when it submerged, there may be mechanical damage, such as bent connecting rods. If the engine binds when cranked, do not attempt to run the engine until it has been repaired.

## TAKING CARE OF UNEXPECTED PROBLEMS

---

### NOTICE

*When cranking the engine with an open ignition circuit (spark plugs removed from the ignition circuit), remove the clip from the emergency stop switch or engine stop switch to prevent possible damage to the ignition system.*

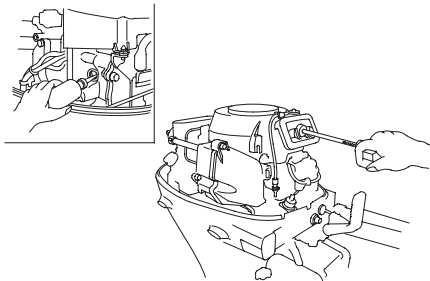

5. Pour a teaspoon of engine oil into each spark plug hole, then pull the recoil starter grip several times to lubricate the inside of the cylinders.
6. Reinstall the spark plugs, and put the emergency stop switch or engine stop switch clip into the switch.

7. Attempt to start the engine.

If the engine fails to start, remove the spark plugs, dry them, then reinstall the spark plugs and attempt to start the engine again.

If the engine starts, and no mechanical damage is evident, continue to run the engine for a half hour or longer. Be sure the water level is at least two inches above the antiventilation plate to avoid overheating and water pump damage.

8. As soon as possible, take the outboard motor to an authorized Honda marine dealer for inspection and service.

# TECHNICAL AND CONSUMER INFORMATION

## TECHNICAL INFORMATION

### Serial Number Locations

Record the product identification number, the engine serial number and the date of purchase in the space provided on this page. You will need these numbers when ordering parts, and when making technical or warranty inquiries (p. 120 ).

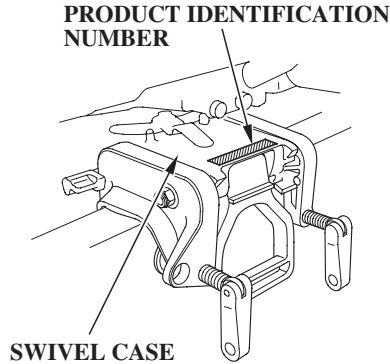

The product identification number is stamped on a plate attached on top of the swivel case.

Product identification number:

---

Date of purchase:

---

### ENGINE SERIAL NUMBER

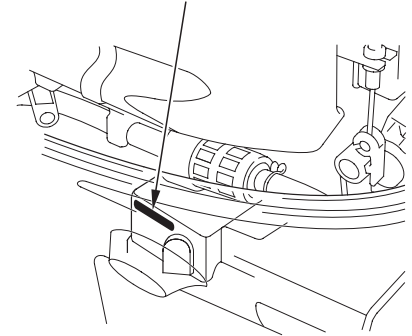

The engine serial number is stamped on the right front of the engine.

Engine serial number:

---

## TECHNICAL AND CONSUMER INFORMATION

---

### Carburetor Modification for High Altitude Operation

At high altitude, the standard carburetor air-fuel mixture will be too rich. Performance will decrease, and fuel consumption will increase. A very rich mixture will also foul the spark plugs and cause hard starting.

High altitude performance can be improved by specific modifications to the carburetors. If you always operate your outboard motor at altitudes above 5,000 feet (1,500 meters), have an authorized Honda marine dealer perform this carburetor modification.

Even with carburetor modification, engine horsepower will decrease about 3.5% for each 1,000-foot (300-meter) increase in altitude. The effect of altitude on horsepower will be greater than this if no carburetor modification is made.

#### NOTICE

*When the carburetors have been modified for high altitude operation, the air-fuel mixture will be too lean for low altitude use. Operation at altitudes below 5,000 feet (1,500 meters) with modified carburetors may cause the engine to overheat and result in serious engine damage. For use at low altitudes, have an authorized Honda marine dealer return the carburetors to original factory specifications.*

## TECHNICAL AND CONSUMER INFORMATION

---

### Oxygenated Fuels

Some conventional gasolines are being blended with alcohol or an ether compound. These gasolines are collectively referred to as oxygenated fuels. To meet clean air standards, some areas of the United States and Canada use oxygenated fuels to help reduce emissions.

If you use an oxygenated fuel, be sure it is unleaded and meets the minimum octane rating requirement.

Before using an oxygenated fuel, try to confirm the fuel's contents. Some states/provinces require this information to be posted on the pump.

The following are the EPA-approved percentages of oxygenates:

**ETHANOL:** ethyl or grain alcohol; 10% by volume.

You may use gasoline containing up to 10% ethanol by volume. Gasoline containing ethanol may be marketed under the name "Gasohol".

**MTBE:** Methyl Tertiary Butyl Ether; 15% by volume.

You may use gasoline containing up to 15% MTBE by volume.

**METHANOL:** methyl or wood alcohol; 5% by volume.

You may use gasoline containing up to 5% methanol by volume, as long as it also contains cosolvents and corrosion inhibitors to protect the fuel system. Gasoline containing more than 5% methanol by volume may cause starting and/or performance problems. It may also

damage metal, rubber, and plastic parts of your fuel system.

If you notice any undesirable operating symptoms, try another service station, or switch to another brand of gasoline.

Fuel system damage or performance problems resulting from the use of an oxygenated fuel containing more than the percentages of oxygenates mentioned above are not covered under warranty.

## TECHNICAL AND CONSUMER INFORMATION

---

### **Emission Control System Information**

#### *Source of Emissions*

The combustion process produces carbon monoxide, oxides of nitrogen, and hydrocarbons. Control of hydrocarbons and oxides of nitrogen is very important because, under certain conditions, they react to form photochemical smog when subjected to sunlight. Carbon monoxide does not react in the same way, but it is toxic.

Honda utilizes lean carburetor settings and other systems to reduce the emissions of carbon monoxide, oxides of nitrogen, and hydrocarbons.

### *The U.S. and California Clean Air Acts*

EPA and California regulations require all manufacturers to furnish written instructions describing the operation and maintenance of emission control systems.

The following instructions and procedures must be followed in order to keep the emissions from your Honda engine within the emission standards.

### *Tampering and Altering*

Tampering with or altering the emission control system may increase emissions beyond the legal limit. Among those acts that constitute tampering are:

- Removal or alteration of any part of the intake, fuel, or exhaust systems.
- Alterations that would cause the engine to operate outside its design parameters.

### ***Problems That May Affect Emissions***

If you are aware of any of the following symptoms, have your engine inspected and repaired by your servicing dealer.

- Hard starting or stalling after starting.
- Rough idle.
- Misfiring or backfiring under load.
- Afterburning (backfiring).
- Black exhaust smoke or high fuel consumption.

### ***Replacement Parts***

The emission control systems on your Honda engine were designed, built, and certified to conform with EPA and California emission regulations. We recommend the use of genuine Honda parts whenever you have maintenance done. These original-design replacement parts are manufactured to the same standards as the original parts, so you can be confident of their performance. The use of replacement parts that are not of the original design and quality may impair the effectiveness of your emission control system.

A manufacturer of an aftermarket part assumes the responsibility that the part will not adversely affect emission performance. The manufacturer or rebuilder of the part must certify that use of the part will not result in a failure of the engine to comply with emission regulations.

### ***Maintenance***

Follow the maintenance schedule on p. 68. Remember that this schedule is based on the assumption that your machine will be used for its designed purpose. Sustained high-load operation, or use in unusual conditions, will require more frequent service.

## TECHNICAL AND CONSUMER INFORMATION

---

### Star Label

A Star label was applied to this outboard motor in accordance with the requirements of the California Air Resources Board.

### *The Star Label means Cleaner Marine Engine*

This engine has been certified as a:



### The Symbol for Cleaner Marine Engines:

**Cleaner Air and Water** - for healthier lifestyle and environment.

**Better Fuel Economy** - burns up to 30 - 40 percent less gas and oil than conventional carbureted two-stroke engines, saving money and resources.

**Longer Emission Warranty** - protects consumer for worry-free operation.



## TECHNICAL AND CONSUMER INFORMATION

---



### **One Star Low Emission**

The one-star label identifies engines that meet the Air Resources Board's Personal Watercraft and Outboard marine engine 2001 exhaust emission standards. Engines meeting these standards have 75% lower emissions than conventional carbureted two-stroke engines. These engines are equivalent to the U.S. EPA's 2006 standards for marine engines.



### **Two Stars Very Low Emission**

The two-star label identifies engines that meet the Air Resources Board's Personal Watercraft and Outboard marine engine 2004 exhaust emission standards. Engines meeting these standards have 20% lower emissions than One Star-Low Emission engines.



### **Three Stars Ultra Low Emission**

The three-star label identifies engines that meet the Air Resources Board's Personal Watercraft and Outboard marine engine 2008 exhaust emission standards or the Sterndrive and inboard marine engine 2003-2008 exhaust emission standards. Engines meeting these standards have 65% lower emissions than One Star-Low Emission engines.



### **Four Stars Super Ultra Low Emission**

The four-star label identifies engines that meet the Air Resources Board's Sterndrive and Inboard marine engine 2009 exhaust emission standards. Personal Watercraft and Outboard marine engines may also comply with these standards. Engines meeting these standards have 90% lower emissions than One Star-Low Emission engines.

Cleaner Watercraft - Get the Facts  
1-800-END-SMOG  
[www.arb.ca.gov](http://www.arb.ca.gov)

# TECHNICAL AND CONSUMER INFORMATION

## Specifications

MODEL		BF8D/BFP8D				
Description Code		BAAJ				
Type		H	HS	HT	R	RT
Overall length		24.0 in (610 mm)			23.6 in (600 mm)	
Overall width		13.6 in (345 mm)				
Overall height	S	43.5 in (1,105 mm)				
	L	48.6 in (1,235 mm)				
	X	54.1 in (1,375 mm)				
Transom height	S	17.0 in (433 mm)				
	L	22.2 in (563 mm)				
	X	27.7 in (703 mm)				
Weight	S	92.6 lbs (42.0 kg)	100.3 lbs (45.5 kg)	_____	_____	_____
	L	98.1 lbs (44.5 kg)	105.8 lbs (48.0 kg)	123.5 lbs (56.0 kg)	106.9 lbs (48.5 kg)	121.3 lbs (55.0 kg)
	X	106.9 lbs (48.5 kg)	114.6 lbs (52.0 kg)	_____	_____	_____
Rated power		6.0 kW (8.0 HP)				
Full throttle range		4,500–5,500 rpm				
Engine type		4 stroke OHC in-line 2 cylinder, water-cooled				
Displacement		13.5 cu-in (222 cm <sup>3</sup> )				
Starter system		Recoil starter	Recoil starter, Electric starter			
Ignition system		Digital ICM (Ignition Control Module)				
Lubrication system		Trochoid pump pressure lubrication				
Specified oil		Engine: API Service classification (SG, SH, SJ, SL) SAE 10W-30 Gear case: API Service classification (GL-4/5) SAE 90 Hypoid gear oil				

Honda outboards are power rated in accordance with NMMA procedures and using the ICOMIA standard 28/23.

## TECHNICAL AND CONSUMER INFORMATION

Oil capacity	Engine: 1.1 US qt (1.0 ℓ) without oil filter change Gear case: 0.301 US qt (0.285 ℓ)		
CARB star label	ULTRA · LOW EMISSION		
D.C. output	12V – 6A	12V – 12A	12V – 12A
Cooling system	Water cooling with thermostat		
Exhaust system	Under water exhaust/thru hub		
Spark plugs	CR5EH-9 (NGK) , U16FER9 (DENSO)		
Fuel pump	Diaphragm type fuel pump		
Fuel	Automotive unleaded gasoline (91 research octane, 86 pump octane, or higher)		
Tank capacity	3.2 US gal (12 ℓ)		
Gear change	Forward-Neutral-Reverse (dog type)		
Steering angle	45° right and left		
Transom angle	(Manual tilt type): 5 stages (4°, 8°, 12°, 16°, 20°)		
	(T type): 4 stages (8°, 12°, 16°, 20°)		
Tilt angle	(Manual tilt S and L handle type): 3 stages adjustment (30°, 45° and 71°/transom angle at 4°)		
	(Manual tilt X handle type, and R type): 3 stages adjustment (30°, 45° and 72°/transom angle at 4°) (T type): Stageless (0° to 68°/transom angle at 8°)		
Remote control steering system	_____		Motor-mounted

### ***Tuneup***

Spark plug gap	0.031 – 0.035 in (0.80 – 0.90 mm)	Refer to page 78.
Idle speed	900 ± 50 rpm	See shop manual
Valve clearance (cold)	IN: 0.17 ± 0.02 mm EX: 0.23 ± 0.02 mm	See shop manual
Other specifications	No other adjustments needed.	

Honda outboards are power rated in accordance with NMMA procedures and using the ICOMIA standard 28/23.

# TECHNICAL AND CONSUMER INFORMATION

## Specifications

MODEL		BF9.9D/BFP9.9D				
Description Code		BABJ				
Type		H	HS	HT	R	RT
Overall length		24.0 in (610 mm)			23.6 in (600 mm)	
Overall width		13.6 in (345 mm)				
Overall height	S	43.5 in (1,105 mm)				
	L	48.6 in (1,235 mm)				
	X	54.1 in (1,375 mm)				
Transom height	S	17.0 in (433 mm)				
	L	22.2 in (563 mm)				
	X	27.7 in (703 mm)				
Weight	S	92.6 lbs (42.0 kg)	100.3 lbs (45.5 kg)	_____	_____	117.9 lbs (53.5 kg)
	L	98.1 lbs (44.5 kg)	105.8 lbs (48.0 kg)	123.5 lbs (56.0 kg)	106.9 lbs (48.5 kg)	121.3 lbs (55.0 kg)
	X	106.9 lbs (48.5 kg)	114.6 lbs (52.0 kg)	129.0 lbs (58.5 kg)	_____	126.8 lbs (57.5 kg)
Rated power		7.4 kW (9.9 HP)				
Full throttle range		5,000–6,000 rpm				
Engine type		4 stroke OHC in-line 2 cylinder, water-cooled				
Displacement		13.5 cu-in (222 cm <sup>3</sup> )				
Starter system		Recoil starter	Recoil starter, Electric starter			
Ignition system		Digital ICM (Ignition Control Module)				
Lubrication system		Trochoid pump pressure lubrication				
Specified oil		Engine: API Service classification (SG, SH, SJ, SL) SAE 10W-30 Gear case: API Service classification (GL-4/5) SAE 90 Hypoid gear oil				

Honda outboards are power rated in accordance with NMMA procedures and using the ICOMIA standard 28/23.

## TECHNICAL AND CONSUMER INFORMATION

Oil capacity	Engine: 1.1 US qt (1.0 ℓ) without oil filter change Gear case: 0.301 US qt (0.285 ℓ)		
CARB star label	ULTRA · LOW EMISSION		
D.C. output	12V – 6A	12V – 12A	12V – 12A
Cooling system	Water cooling with thermostat		
Exhaust system	Under water exhaust/thru hub		
Spark plugs	CR5EH-9 (NGK) , U16FER9 (DENSO)		
Fuel pump	Diaphragm type fuel pump		
Fuel	Automotive unleaded gasoline (91 research octane, 86 pump octane, or higher)		
Tank capacity	3.2 US gal (12 ℓ)		
Gear change	Forward-Neutral-Reverse (dog type)		
Steering angle	45° right and left		
Transom angle	(Manual tilt type): 5 stages (4°, 8°, 12°, 16°, 20°)		
	(T type): 4 stages (8°, 12°, 16°, 20°)		
Tilt angle	(Manual tilt S and L handle type): 3 stages adjustment (30°, 45° and 71°/transom angle at 4°)		
	(Manual tilt X handle type, and R type): 3 stages adjustment (30°, 45° and 72°/transom angle at 4°) (T type): Stageless (0° to 68°/transom angle at 8°)		
Remote control steering system	_____		Motor-mounted

### ***Tuneup***

Spark plug gap	0.031 – 0.035 in (0.80 – 0.90 mm)	Refer to page 78.
Idle speed	900 ± 50 rpm	See shop manual
Valve clearance (cold)	IN: 0.17 ± 0.02 mm EX: 0.23 ± 0.02 mm	See shop manual
Other specifications	No other adjustments needed.	

Honda outboards are power rated in accordance with NMMA procedures and using the ICOMIA standard 28/23.

# TECHNICAL AND CONSUMER INFORMATION

## Specifications

MODEL	BF15D/BFP15D						
Description Code	BALJ						
Type	H	HS	HG	HT	R	RT	
Overall length	25.6 in (650 mm)				25.2 in (640 mm)		
Overall width	13.8 in (350 mm)						
Overall height	S	43.7 in (1,110 mm)					
	L	48.8 in (1,240 mm)					
	X	54.3 in (1,380 mm)					
Transom height	S	17.0 in (433 mm)					
	L	22.2 in (563 mm)					
	X	27.7 in (703 mm)					
Weight	S	102.5 lbs (46.5 kg)	108.0 lbs (49.0 kg)	123.5 lbs (56.0 kg)	126.8 lbs (57.5 kg)	_____	125.7 lbs (57.0 kg)
	L	109.1 lbs (49.5 kg)	114.6 lbs (52.0 kg)	126.8 lbs (57.5 kg)	131.2 lbs (59.5 kg)	112.4 lbs (51.0 kg)	129.0 lbs (58.5 kg)
	X	114.6 lbs (52.0 kg)	_____	132.3 lbs (60.0 kg)	136.7 lbs (62.0 kg)	_____	134.5 lbs (61.0 kg)
Rated power	11.2 kW (15 HP)						
Full throttle range	4,500 – 5,500 rpm						
Engine type	4 stroke OHC in-line 2 cylinder, water-cooled						
Displacement	21.4 cu-in (350 cm <sup>3</sup> )						
Starter system	Recoil starter	Recoil starter, Electric starter					
Ignition system	Digital ICM (Ignition Control Module)						
Lubrication system	Trochoid pump pressure lubrication						
Specified oil	Engine: API Service classification (SG, SH, SJ, SL) SAE 10W-30 Gear case: API Service classification (GL-4/5) SAE 90 Hypoid gear oil						

Honda outboards are power rated in accordance with NMMA procedures and using the ICOMIA standard 28/23.

## TECHNICAL AND CONSUMER INFORMATION

Oil capacity	Engine: 1.1 US qt (1.0 ℓ) without oil filter change Gear case: 0.301 US qt (0.285 ℓ)		
CARB star label	ULTRA · LOW EMISSION		
D.C. output	12V – 6A	12V – 12A	12V – 12A
Cooling system	Water cooling with thermostat		
Exhaust system	Under water exhaust/thru hub		
Spark plugs	CR5EH-9 (NGK) , U16FER9 (DENSO)		
Fuel pump	Diaphragm type fuel pump		
Fuel	Automotive unleaded gasoline (91 research octane, 86 pump octane, or higher)		
Tank capacity	3.2 US gal (12 ℓ)		
Gear change	Forward-Neutral-Reverse (dog type)		
Steering angle	45° right and left		
Transom angle	(Manual tilt type): 5 stages (4°, 8°, 12°, 16°, 20°)		
	(G and T types): 4 stages (8°, 12°, 16°, 20°)		
Tilt angle	(Manual tilt S handle type): 3 stages adjustment (30°, 45° and 71°/transom angle at 4°)		
	(Manual tilt L and X handle types, and R types): 3 stages adjustment (30°, 45° and 72°/transom angle at 4°) (G and T types): Stageless (0° to 68°/transom angle at 8°)		
Remote control steering system	_____		Motor-mounted

### ***Tuneup***

Spark plug gap	0.031 – 0.035 in (0.80 – 0.90 mm)	Refer to page 78.
Idle speed	900 ± 50 rpm	See shop manual
Valve clearance (cold)	IN: 0.17 ± 0.02 mm EX: 0.23 ± 0.02 mm	See shop manual
Other specifications	No other adjustments needed.	

Honda outboards are power rated in accordance with NMMA procedures and using the ICOMIA standard 28/23.

# TECHNICAL AND CONSUMER INFORMATION

## Specifications

MODEL		BF20D/BFP20D					
Description Code		BAMJ					
Type		H	HS	HG	HT	R	RT
Overall length		25.6 in (650 mm)				25.2 in (640 mm)	
Overall width		13.8 in (350 mm)					
Overall height	S	43.7 in (1,110 mm)					
	L	48.8 in (1,240 mm)					
	X	54.3 in (1,380 mm)					
Transom height	S	17.0 in (433 mm)					
	L	22.2 in (563 mm)					
	X	27.7 in (703 mm)					
Weight	S	102.5 lbs (46.5 kg)	108.0 lbs (49.0 kg)	123.5 lbs (56.0 kg)	126.8 lbs (57.5 kg)	109.1 lbs (49.5 kg)	125.7 lbs (57.0 kg)
	L	109.1 lbs (49.5 kg)	114.6 lbs (52.0 kg)	126.8 lbs (57.5 kg)	131.2 lbs (59.5 kg)	112.4 lbs (51.0 kg)	129.0 lbs (58.5 kg)
	X	_____	120.2 lbs (54.5 kg)	132.3 lbs (60.0 kg)	136.7 lbs (62.0 kg)	_____	_____
Rated power		14.9 kW (20 HP)					
Full throttle range		5,000 – 6,000 rpm					
Engine type		4 stroke OHC in-line 2 cylinder, water-cooled					
Displacement		21.4 cu-in (350 cm <sup>3</sup> )					
Starter system	Recoil starter	Recoil starter, Electric starter					
Ignition system		Digital ICM (Ignition Control Module)					
Lubrication system		Trochoid pump pressure lubrication					
Specified oil		Engine: API Service classification (SG, SH, SJ, SL) SAE 10W-30 Gear case: API Service classification (GL-4/5) SAE 90 Hypoid gear oil					

Honda outboards are power rated in accordance with NMMA procedures and using the ICOMIA standard 28/23.



## TECHNICAL AND CONSUMER INFORMATION

Oil capacity	Engine: 1.1 US qt (1.0 ℓ) without oil filter change Gear case: 0.301 US qt (0.285 ℓ)		
CARB star label	ULTRA · LOW EMISSION		
D.C. output	12V – 6A	12V – 12A	12V – 12A
Cooling system	Water cooling with thermostat		
Exhaust system	Under water exhaust/thru hub		
Spark plugs	CR5EH-9 (NGK) , U16FER9 (DENSO)		
Fuel pump	Diaphragm type fuel pump		
Fuel	Automotive unleaded gasoline (91 research octane, 86 pump octane, or higher)		
Tank capacity	3.2 US gal (12 ℓ)		
Gear change	Forward-Neutral-Reverse (dog type)		
Steering angle	45° right and left		
Transom angle	(Manual tilt type): 5 stages (4°, 8°, 12°, 16°, 20°)		
	(G and T types): 4 stages (8°, 12°, 16°, 20°)		
Tilt angle	(Manual tilt S handle type): 3 stages adjustment (30°, 45° and 71°/transom angle at 4°)		
	(Manual tilt L and X handle types, and R types): 3 stages adjustment (30°, 45° and 72°/transom angle at 4°) (G and T types): Stageless (0° to 68°/transom angle at 8°)		
Remote control steering system	_____		Motor-mounted

### ***Tuneup***

Spark plug gap	0.031 – 0.035 in (0.80 – 0.90 mm)	Refer to page 78.
Idle speed	900 ± 50 rpm	See shop manual
Valve clearance (cold)	IN: 0.17 ± 0.02 mm EX: 0.23 ± 0.02 mm	See shop manual
Other specifications	No other adjustments needed.	

Honda outboards are power rated in accordance with NMMA procedures and using the ICOMIA standard 28/23.

## TECHNICAL AND CONSUMER INFORMATION

---

### CONSUMER INFORMATION

#### **Honda Publications**

These publications will give you additional information for maintaining and repairing your outboard motor. You may purchase them from your Honda marine dealer.

#### ***Shop Manual***

This manual covers complete maintenance and overhaul procedures. It is intended to be used by a skilled technician.

#### ***Parts Catalog***

This manual provides complete, illustrated parts lists.

### Customer Service Information

#### ***Contacting Honda***

Your owner's manual was written to cover most of the questions you might ask about your Honda. Any questions not answered in the owner's manual can be answered by your Honda dealer. If your dealer doesn't have an immediate answer, they should be able to get it for you.

If you have a difference of opinion with your dealer, please remember that each dealership is independently owned and operated. That's why it's important to work to resolve any differences at the dealership level. If the service personnel are unable to assist you, please discuss your concerns with the dealer management such as the Service Manager or Dealer Owner.

If you need to contact American Honda regarding your experiences with your Honda product or with

your dealer, please send your comments to the following address:

**American Honda Motor Co., Inc.**  
Marine Division  
Customer Relations Office  
4900 Marconi Drive  
Alpharetta, GA 30005-8847  
Telephone (770)497-6400  
M-F 8:30am-7:00pm (Eastern Time Zone)

## TECHNICAL AND CONSUMER INFORMATION

---

Please include the following information in your communication:

- Your name, address and telephone number (complete with area code)
- Model and complete serial number
- Date of purchase
- Name and location of selling dealer
- Name and location of servicing dealer (if different)
- A detailed description of your concerns

We will likely ask your Honda dealer to respond, or possibly acknowledge your comments directly.

### *Warranty Coverage*

Your new Honda is covered by the following warranties:

- Distributor's Limited Warranty
- Emission Control Warranty

Please read the warranty statements contained in this manual. There are responsibilities, restrictions, and exclusions that apply to these warranties.

To obtain warranty service you must take your Honda outboard engine, together with proof of original retail purchase date, at your expense, to a Honda engine dealer or distributor authorized to sell that product in the United States, Puerto Rico, or the U.S. Virgin Islands.

It is important to realize that your warranty applies to defects in material or workmanship of your Honda. Your warranty coverage does not apply to normal wear or

deterioration associated with using your Honda outboard.

Your warranty coverage will not be voided if you choose to perform your own maintenance. However, you should have the proper tools and service information and be mechanically qualified. Failures that occur due to modifications, improper maintenance or service are not covered.

## TECHNICAL AND CONSUMER INFORMATION

---

### *Warranty Service*

Please remember that recommended maintenance interval servicing is not included in your warranty coverage. Additionally, your warranty does not apply to the normal wear of items (such as spark plug(s), water pump, etc.).

As the owner of a Honda product, your servicing dealer may ask you to authorize an inspection. If the problem is covered under warranty, your dealer will perform any warranty repairs for you at no cost. However, you may be responsible for additional non-warranty charges.

If you have questions about warranty coverage or the nature of the repair, it is best to talk to the service manager of your Honda dealer.

Sometimes, in spite of the best intentions of all concerned, a misunderstanding may occur. If you aren't satisfied with your dealer's

handling of the situation, we suggest you discuss your problem with the appropriate member of the dealership's management team. If the problem has already been reviewed with the appropriate manager of the Service, Parts, or Sales department, contact the owner of the dealership or their designated representative.

## TECHNICAL AND CONSUMER INFORMATION

### Distributor's Limited Warranty — 2006

This warranty is limited to Honda Outboard Motors distributed by American Honda Motor Co., Inc., Power Equipment Division, 4900 Marconi Drive, Alpharetta, Georgia 30005-8847.

PRODUCTS COVERED BY WARRANTY	LENGTH OF WARRANTY: (FROM DATE OF ORIGINAL PURCHASE)	
	NONCOMMERCIAL/ NONRENTAL	COMMERCIAL/ RENTAL
All Outboard Motors	36 Months	12 Months

#### TO QUALIFY FOR THIS WARRANTY:

The Honda Outboard Motor must be purchased from American Honda or a dealer authorized by American Honda to sell Honda Outboard Motors in the United States, Puerto Rico, or the U.S. Virgin Islands. This limited warranty applies to the first retail purchaser and each subsequent owner during the applicable warranty time period.

#### WHAT AMERICAN HONDA WILL REPAIR OR REPLACE UNDER WARRANTY:

American Honda will repair or replace, at its option, any part that is proven to be defective in material or workmanship under normal use during the applicable warranty time period. Warranty repairs and replacements will be made without charge for parts or labor. Anything replaced under warranty becomes the property of American Honda Motor Company, Inc. All parts replaced under warranty will be considered as part of the original product and any warranty on those parts will expire coincidentally with the original product warranty.

#### TO OBTAIN WARRANTY SERVICE:

You must take your Honda Outboard Motor and proof of the original purchase date, at your expense, to any dealer who is authorized to service Honda Outboard Motors in the United States, Puerto Rico, or the U.S. Virgin Islands, during the dealer's normal business hours. If you are unable to obtain warranty service, or are dissatisfied with the warranty service you receive, take the following steps: First, contact the owner of the dealership involved; normally this should resolve the problem. However, if you should require further assistance, write or call the Honda Marine Customer Relations. Please see *Contacting Honda* page 120 .

## TECHNICAL AND CONSUMER INFORMATION

---

### **EXCLUSIONS:**

THIS WARRANTY DOES NOT EXTEND TO THE FOLLOWING:

- CONDITIONS CAUSED BY LACK OF ROUTINE MAINTENANCE (AS OUTLINED IN THE OWNERS MANUAL)
- CONDITIONS CAUSED BY THE USE OF PROPELLER(S) THAT DO NOT ALLOW THE OUTBOARD MOTOR TO RUN IN ITS RECOMMENDED FULL THROTTLE RPM RANGE
- OPERATION INCONSISTENT WITH THE RECOMMENDED OPERATION/DUTY CYCLE (AS OUTLINED IN THE OWNERS MANUAL)
- PARTS AFFECTED OR DAMAGED BY AN ACCIDENT AND/OR COLLISION
- NORMAL WEAR AND TEAR
- FUEL CONTAMINATION AND WATER ENTERING ENGINE THROUGH THE FUEL INTAKE, AIR INTAKE OR EXHAUST SYSTEM
- OPERATION WITH FUELS, OILS, ADDITIVES AND LUBRICANTS WHICH ARE NOT SUITABLE FOR USE IN THE PRODUCT
- USE IN AN APPLICATION FOR WHICH THE OUTBOARD MOTOR WAS NOT DESIGNED, SUCH AS RACING OR COMPETITIVE USE OR ANY OTHER MISUSE OR NEGLECT
- INCORPORATION OF UNSUITABLE ATTACHMENTS OR PARTS

- THE UNAUTHORIZED ALTERATION, IMPROPER INSTALLATION, OR ANY CAUSES OTHER THAN DEFECTS IN MATERIAL OR WORKMANSHIP
- CORROSION TO STEERING SYSTEM OR ELECTRICAL COMPONENTS, CORROSION DUE TO ELECTROLYSIS, WATER BORN FOREIGN CHEMICALS, IMPROPER SERVICE OR CORROSION CAUSED BY DAMAGE OR ABUSE
- REIMBURSEMENT FOR TOWING CHARGES, IN AND OUT OF WATER CHARGES, OR TECHNICIAN TRAVEL TIME
- GROWTH OF MARINE ORGANISMS ON MOTOR SURFACES, EXTERNAL OR INTERNAL

**DISCLAIMER OF CONSEQUENTIAL DAMAGE AND LIMITATION OF IMPLIED WARRANTIES:** AMERICAN HONDA DISCLAIMS ANY RESPONSIBILITY FOR LOSS OF TIME OR USE OF THE OUTBOARD, REVENUE, OR THE EQUIPMENT IN WHICH THE OUTBOARD IS INSTALLED, TRANSPORTATION, COMMERCIAL LOSS, OR ANY OTHER INCIDENTAL OR CONSEQUENTIAL DAMAGE. ANY IMPLIED WARRANTIES ARE LIMITED TO THE DURATION OF THIS WRITTEN LIMITED WARRANTY. Some states do not allow limitations on how long an implied warranty lasts and/or do not allow the exclusion or limitation of incidental or

## TECHNICAL AND CONSUMER INFORMATION

### ACCESSORIES AND REPLACEMENT PARTS

This warranty is limited to Honda Power Equipment parts, accessories and apparel when distributed by American Honda Motor Co., Inc., 1919 Torrance Blvd., Torrance, California 90501-2746.

PRODUCTS COVERED BY WARRANTY	LENGTH OF WARRANTY: (FROM DATE OF ORIGINAL PURCHASE)	
	NONCOMMERCIAL/ NONRENTAL	COMMERCIAL/ RENTAL
Accessories	12 Months	3 Months
Replacement Parts	6 Months	3 Months

### TO QUALIFY FOR THIS WARRANTY:

1. The accessories or replacement parts must be purchased from American Honda, or a dealer, distributor or distributor's dealer authorized by American Honda to sell those products in the United States, Puerto Rico, and the U.S. Virgin Islands.
2. You must be the first retail purchaser. This warranty is not transferable to subsequent owners.

### WHAT AMERICAN HONDA WILL REPAIR OR REPLACE UNDER WARRANTY:

American Honda will repair or replace, at its option, any marine product accessories or replacement parts that are proven to be defective in material or workmanship under normal use during the applicable warranty time period. Anything replaced under warranty becomes the property of American Honda Motor Company, Inc. All parts replaced under warranty will be considered as part of the original product and any warranty on those parts will expire coincidentally with the original product warranty. Accessories and replacement parts, installed by a dealer who is authorized by American Honda to sell them, will be repaired or replaced under warranty without charge for parts or labor. If installed by anyone else, accessories and replacement parts will be repaired or replaced under warranty without charge for parts, but any labor charges will be the responsibility of the purchaser.

## TECHNICAL AND CONSUMER INFORMATION

---

### **TO OBTAIN WARRANTY SERVICE:**

You must take the Honda Outboard Motor product accessory or replacement part or the outboard motor or boat on which the accessory or replacement part is installed, and proof of purchase, at your expense, to any Honda Outboard Motor dealer in the United States, Puerto Rico, or the U.S. Virgin Islands who is authorized to sell that product, during the dealer's normal business hours.

If you are unable to obtain warranty service, or are dissatisfied with the warranty service you receive, take the following steps: First, contact the owner of the dealership or distributorship involved; normally this will resolve the problem. However, if you should require further assistance, write or call the Honda Marine Customer Relations Department of American. Please see *Contacting Honda* page 120 .

**THIS WARRANTY DOES NOT EXTEND TO ACCESSORIES OR PARTS AFFECTED OR DAMAGED BY ACCIDENT AND/OR COLLISION, NORMAL WEAR, USE IN AN APPLICATION FOR WHICH THE PRODUCT WAS NOT DESIGNED OR ANY OTHER MISUSE, NEGLIGENCE, INCORPORATION OR USE OF UNSUITABLE ATTACHMENTS OR PARTS, UNAUTHORIZED ALTERATION, IMPROPER INSTALLATION, OR ANY CAUSES OTHER THAN DEFECTS IN**

**MATERIAL OR WORKMANSHIP OF THE PRODUCT.**

### **DISCLAIMER OF CONSEQUENTIAL DAMAGE AND LIMITATION OF IMPLIED WARRANTIES:**

AMERICAN HONDA DISCLAIMS ANY RESPONSIBILITY FOR LOSS OF TIME OR USE OF THE HONDA OUTBOARD MOTOR, OR THE BOAT ON WHICH THE PRODUCT IS INSTALLED, TRANSPORTATION, COMMERCIAL LOSS, OR ANY OTHER INCIDENTAL OR CONSEQUENTIAL DAMAGE. ANY IMPLIED WARRANTIES ARE LIMITED TO THE DURATION OF THIS WRITTEN WARRANTY. Some states do not allow limitations on how long an implied warranty lasts and/or do not allow the exclusion or limitation of incidental or consequential damages, so the above exclusions and limitations may not apply to you. This warranty gives you specific legal rights, and you may also have other rights which vary from state to state.



### Emission Control System Warranty

Your new Honda outboard engine complies with both the U.S. EPA and State of California emission regulations. American Honda provides the same emission warranty coverage for outboard engines sold in all 50 states.

### YOUR WARRANTY RIGHTS AND OBLIGATION

#### California

The California Air Resources Board and American Honda Motor Co., Inc. are pleased to explain the emission control system warranty on your 2001 and later Honda outboard engine. In California, new outboard engines must be designed, built and equipped to meet California's stringent anti-smog emission standards in addition to the U.S. EPA emissions standards.

#### Other States

In other areas of the United States your outboard engine must be designed, built and equipped to meet the U.S. EPA Emission Standard for spark ignited marine engines.

#### All States

American Honda Motor Co., Inc. must warranty the emission control system on your outboard engine for the period of time listed below provided there has been no abuse, neglect or improper maintenance of your outboard engine. Where a warranty condition exists, American Honda Motor Co., Inc. will repair your outboard engine at no cost to you including diagnosis, parts and labor. Your emission control system may include such parts as the carburetor or fuel injection system and catalytic converter. Also included may be hoses, connectors and other emission-related assemblies.

### MANUFACTURER'S EMISSION CONTROL SYSTEM WARRANTY COVERAGE:

The 2001 and later outboard engines are warranted for four years or 250 hours of operation, whichever comes first. However, warranty coverage based on the hourly period is only permitted for outboard engines equipped with appropriate hour meters. If any emission-related part on your outboard engine is defective under warranty, the part will be repaired or replaced by American Honda Motor Co., Inc.

## TECHNICAL AND CONSUMER INFORMATION

---

### **OWNER'S WARRANTY RESPONSIBILITY:**

As the outboard engine owner, you are responsible for the performance of the required maintenance listed in your owner's manual. American Honda Motor Co., Inc. recommends that you retain all receipts covering maintenance on your outboard engine, but American Honda Motor Co., Inc. cannot deny warranty solely for the lack of receipts or for your failure to ensure the performance of all scheduled maintenance. As the outboard engine owner, you should, however, be aware that American Honda Motor Co., Inc. may deny you warranty coverage if your outboard engine or a part has failed due to abuse, neglect, improper maintenance, or unapproved modifications. You are responsible for presenting your outboard engine to a Honda Marine dealer as soon as a problem exists. The warranty repair should be completed in a reasonable amount of time, not to exceed 30 days. If you have any questions regarding your warranty rights and responsibilities, you should contact American Honda Motor Co., Inc., Marine Division Customer Relations Office. Please see *Contacting Honda* page 120 .

### **WARRANTY COVERAGE:**

Honda outboard engines manufactured after June 1, 2000 are covered by this warranty for a period of four years or 250 operating hours, whichever comes first, from the date of delivery to the retail purchaser. This warranty is transferred to each subsequent purchaser for the duration of the warranty period. Warranty repairs will be made without charge for diagnosis, parts and labor. All defective parts replaced under this warranty become the property of American Honda Motor Co., Inc. A list of warranty parts is on page 130. Normal maintenance items, such as spark plugs and filters, that are on the warranted parts list are warranted up to their required replacement interval only. American Honda Motor Co., Inc. is also liable for damages to other engine components caused by a failure of any warranted part during the warranty period. Only Honda approved replacement parts will be used in the performance of any warranty repairs and they will be provided without charge to the owner. The use of replacement parts not equivalent to the original parts may impair the effectiveness of your engine's emission control system. If such a replacement part is used in the repair or maintenance of your engine, and an authorized Honda Marine dealer determines it is defective or causes a failure of a warranted part, your claim for your engine may be denied. If the part in question is not related to the reason that your engine requires repair, your claim will not be denied.

## TECHNICAL AND CONSUMER INFORMATION

---

### **TO OBTAIN WARRANTY SERVICE:**

You must take your Honda outboard engine, along with your sales registration card or other proof of original purchase date, at your expense, to any Honda Marine dealer who is authorized by American Honda Motor Co., Inc. to sell and service that Honda marine product during his normal business hours. Claims for repair or adjustment found to be caused solely by defects in material or workmanship will not be denied because the engine was not properly maintained and used. If you are unable to obtain warranty service, or are dissatisfied with the warranty service you received, contact the owner of the dealership involved. Normally this should resolve your problem. However, if you require further assistance, write or call the Honda Marine Customer Relations Office of American Honda Motor Co., Inc.

### **EXCLUSIONS:**

FAILURES OTHER THAN THOSE RESULTING FROM DEFECTS IN MATERIAL OR WORKMANSHIP ARE NOT COVERED BY THIS WARRANTY. THIS WARRANTY DOES NOT EXTEND TO EMISSION CONTROL SYSTEMS OR PARTS WHICH ARE AFFECTED OR DAMAGED BY OWNER ABUSE, NEGLIGENCE, IMPROPER MAINTENANCE, MISUSE, MISFUELING, IMPROPER STORAGE, ACCIDENT AND/OR COLLISION. THE INCORPORATION OF, OR USE

OF, UNSUITABLE ATTACHMENTS, OR THE UNAUTHORIZED ALTERATION OF ANY PART. THIS WARRANTY DOES NOT COVER REPLACEMENT OF EXPENDABLE MAINTENANCE ITEMS MADE IN CONNECTION WITH REQUIRED MAINTENANCE SERVICE AFTER THE ITEM'S FIRST SCHEDULED REPLACEMENT AS LISTED IN THE MAINTENANCE SECTION OF THE PRODUCT OWNER'S MANUAL, SUCH AS: SPARK PLUGS AND FILTERS.

### **DISCLAIMER OF CONSEQUENTIAL DAMAGE AND LIMITATION OF IMPLIED WARRANTIES:**

American Honda Motor Co., Inc. disclaims any responsibility for incidental or consequential damages such as loss of time or the use of outboard engine, or any commercial loss due to the failure of the equipment; and any implied warranties are limited to the duration of this written warranty. This warranty is applicable only where the California or U.S. EPA emission control system warranty regulation is in effect.

## TECHNICAL AND CONSUMER INFORMATION

---

### EMISSION CONTROL SYSTEM WARRANTY PARTS:

SYSTEMS COVERED BY THIS WARRANTY:	PARTS DESCRIPTION
Fuel Metering	Carburetor assembly, Throttle body, Fuel injector, Fuel pump, Fuel pressure regulator, Throttle position sensor, Intake air temperature sensor, Engine temperature sensor, Manifold absolute pressure sensor, Idle air control valve, Barometric pressure sensor, Fuel line solenoid valve, Intake manifold, Intake valves, and Oxygen sensor or Air fuel ratio sensor
Air Induction	Air intake duct, Crankcase breather tube, Positive crankcase ventilation valve, Vapor separator, Intake manifold tuning valve (Intake air bypass control valve)
Ignition	Flywheel magneto, Ignition pulse generator, Ignition coil assembly, Ignition control module, Engine control module, Crankshaft position sensor, Spark plug cap, Spark plug*, Knock sensor, and Camshaft position sensor
Lubrication system	Oil pump and internal parts
Crankcase Emission Control	Oil filler cap
Exhaust	Exhaust manifold and Exhaust valves
VTEC System	VTEC valve
Miscellaneous Parts	Tubing, fittings, seals, gaskets, and clamps associated with these listed systems.
*Covered up to the first required replacement only. See the Maintenance Schedule in the owner's manual.	

# INDEX

Anodes.....	32	CRUISING.....	58
Replacement.....	84	Customer Service Information.....	120
ARE YOU READY TO GET UNDER WAY ? .....	39	Distributor's Limited Warranty — 2006.....	123
ATTACHMENT.....	35	Electric Starter Button (types equipped with electric starter).....	21
Automatic Choke (types equipped with electric starter).....	32	ELECTRIC STARTER WILL NOT OPERATE.....	94
BATTERY CONNECTIONS.....	36	EMERGENCY STARTING.....	50
BATTERY WILL NOT CHARGE AND ELECTRIC STARTER WILL NOT OPERATE.....	99	Emission Control System Information.....	108
BEFORE OPERATION.....	39	Emission Control System Warranty.....	127
BOAT TRANSOM REQUIREMENTS.....	34	Engine Cover Latch.....	27
BREAK-IN PROCEDURE.....	41	REMOVAL AND INSTALLATION.....	70
Carburetor Modification for High Altitude Operation.....	106	Oil Change.....	72
Cleaning and Flushing.....	87	Level Check .....	71
Choke Knob (manual choke type).....	19	Recommendations.....	74
Choke Knob Friction (manual choke type).....	85	Stop Switch and Switch Clip H Type (tiller handle).....	19
COMPONENT AND CONTROL LOCATIONS.....	14	R Type (remote control).....	23
CONSUMER INFORMATION.....	120	ENGINE OVERHEATS.....	98
CONTROLS.....	19	ENGINE WILL NOT START.....	95
CONTROLS AND FEATURE IDENTIFICATION CODES.....	10		
CONTROLS AND FEATURES .....	10		
Cooling System Indicator.....	31		

# INDEX

---

Fast Idle Lever.....	24	INSTALLATION.....	34
Fuel		INSTALLATION POSITION .....	34
Filler Cap Vent Knob.....	33	INSTRUMENTS.....	29
Filter Inspection and Replacement.....	81	IS YOUR OUTBOARD MOTOR	
Gauge.....	29	READY TO GO ? .....	39
HOSE CONNECTIONS .....	44		
PRIMING .....	45	Lubrication Points .....	77
Priming Bulb .....	33		
RECOMMENDATIONS.....	80	MAINTENANCE SAFETY .....	66
Fuse Replacement .....	99	MAINTENANCE SCHEDULE .....	68
		Manual Relief Valve (T type).....	26, 70
Gear Oil		MOORING, BEACHING, LAUNCHING.....	63
Change.....	75		
Level Check.....	74	Oil filter Change.....	73
GEARSHIFT AND THROTTLE OPERATION .....	55	Oil Pressure Indicator (R type) (H type).....	30
H Type (tiller handle).....	55	OIL PRESSURE INDICATOR LIGHT GOES	
R Type (remote control).....	56	OFF AND ENGINE SPEED IS LIMITED .....	100
Gearshift Lever.....	20	OPERATION .....	41
Gearshift/Trottle Control Lever .....	25	OTHER FEATURES .....	32
		OUTBOARD MOTOR SAFETY.....	7
HARD STARTING OR STALLS AFTER		Overheat Indicator (R type) .....	30
STARTING .....	97	OVERHEAT AND ENGINE SPEED IS	
Honda Publications .....	120	LIMITED .....	101
		Overrev Limiter.....	32
Ignition Switch .....	23	Oxygenated Fuels.....	107
IMPORTANT SAFETY INFORMATION .....	7		
INDICATORS.....	30		

PORTABLE FUEL TANK.....	32, 44	SAFE OPERATING PRECAUTIONS .....	41
Portable Fuel Tank and Filter Cleaning .....	83	SAFETY LABEL LOCATIONS .....	9
POWER REQUIREMENTS.....	34	Serial Number Locations.....	105
Power Tilt Switch (T type)		SERVICING YOUR OUTBOARD MOTOR.....	65
H Type (tiller handle).....	22	SHALLOW WATER OPERATION.....	60
R Type (remote control).....	26	Spark Plug Service .....	78
Propeller Replacement .....	86	Specifications .....	112
		Star Label .....	110
Recoil Starter		STARTING THE ENGINE .....	45
Grip.....	21	H Type (tiller handle).....	45
Rope Inspection.....	84	R Type (remote control).....	48
REFUELING.....	79	STEERING.....	57
REMOVAL FROM STORAGE.....	92	H Type (tiller handle).....	57
		R Type (remote control).....	57
		Steering Friction Lever.....	21
		STOPPING THE ENGINE.....	53
		Emergency Engine Stopping.....	53
		Normal Engine Stopping.....	53
		STORAGE .....	87
		STORAGE PRECAUTIONS.....	91
		STORAGE PREPARATION.....	87
		Fuel.....	88
		Engine oil .....	91
		SUBMERGED MOTOR .....	103

# INDEX

---

Tachometer [optional equipment (R type)].....	29
TAKING CARE OF UNEXPECTED PROBLEMS.....	94
TECHNICAL AND CONSUMER INFORMATION.....	105
TECHNICAL INFORMATION.....	105
THE IMPORTANCE OF MAINTENANCE.....	65
Throttle Friction Adjuster .....	20
Throttle Grip.....	20
Tilt	
Lever (manual tilt type).....	28
Lever (G type) .....	22
Lock Lever (G and T type) .....	27
TOOL KIT AND EMERGENCY STARTER ROPE ...	67
Transom Angle Adjusting Rod .....	27
TRANSOM ANGLE ADJUSTMENT .....	36, 42
TRANSPORTING .....	93
WITH OUTBOARD MOTOR INSTALLED	
ON BOAT .....	93
WITH OUTBOARD MOTOR REMOVED	
FROM BOAT .....	93
WIRING DIAGRAMS .....	Inside back cover



---

**MEMO**

---

**MEMO**

# WIRING DIAGRAM

TILLER HANDLE, MANUAL TILT TYPE  
 (with recoil starter and 6A charge coil)  
 BF8D/BFP8D/BF9.9D/BFP9.9D models

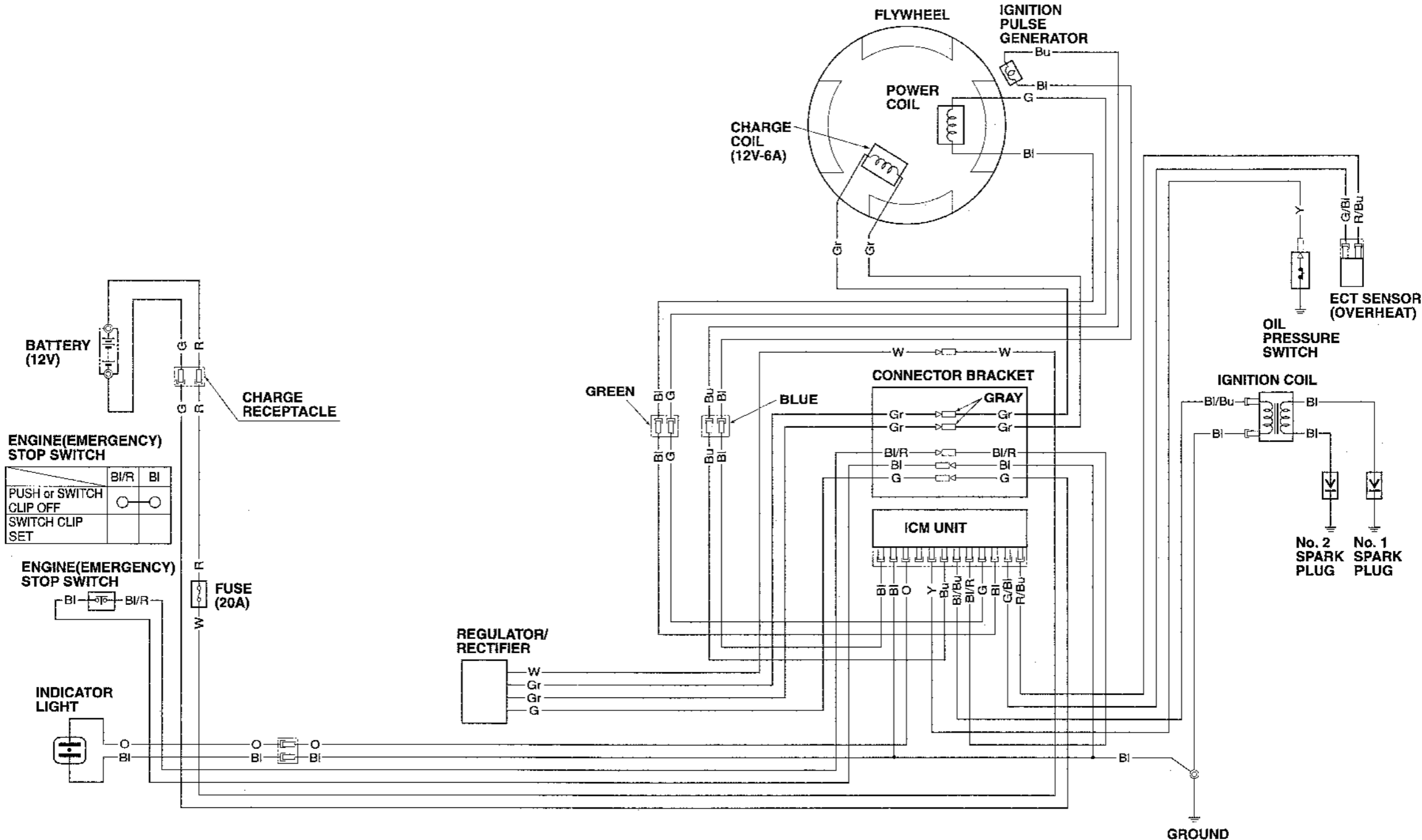

BI	BLACK	Br	BROWN
Y	YELLOW	O	ORANGE
Bu	BLUE	Lb	LIGHT BLUE
G	GREEN	Lg	LIGHT GREEN
R	RED	P	PINK
W	WHITE	Gr	GRAY

# WIRING DIAGRAM

TILLER HANDLE, MANUAL TILT TYPE  
(with electric starter type)  
BF8D/BFP8D/BF9.9D/BFP9.9D models

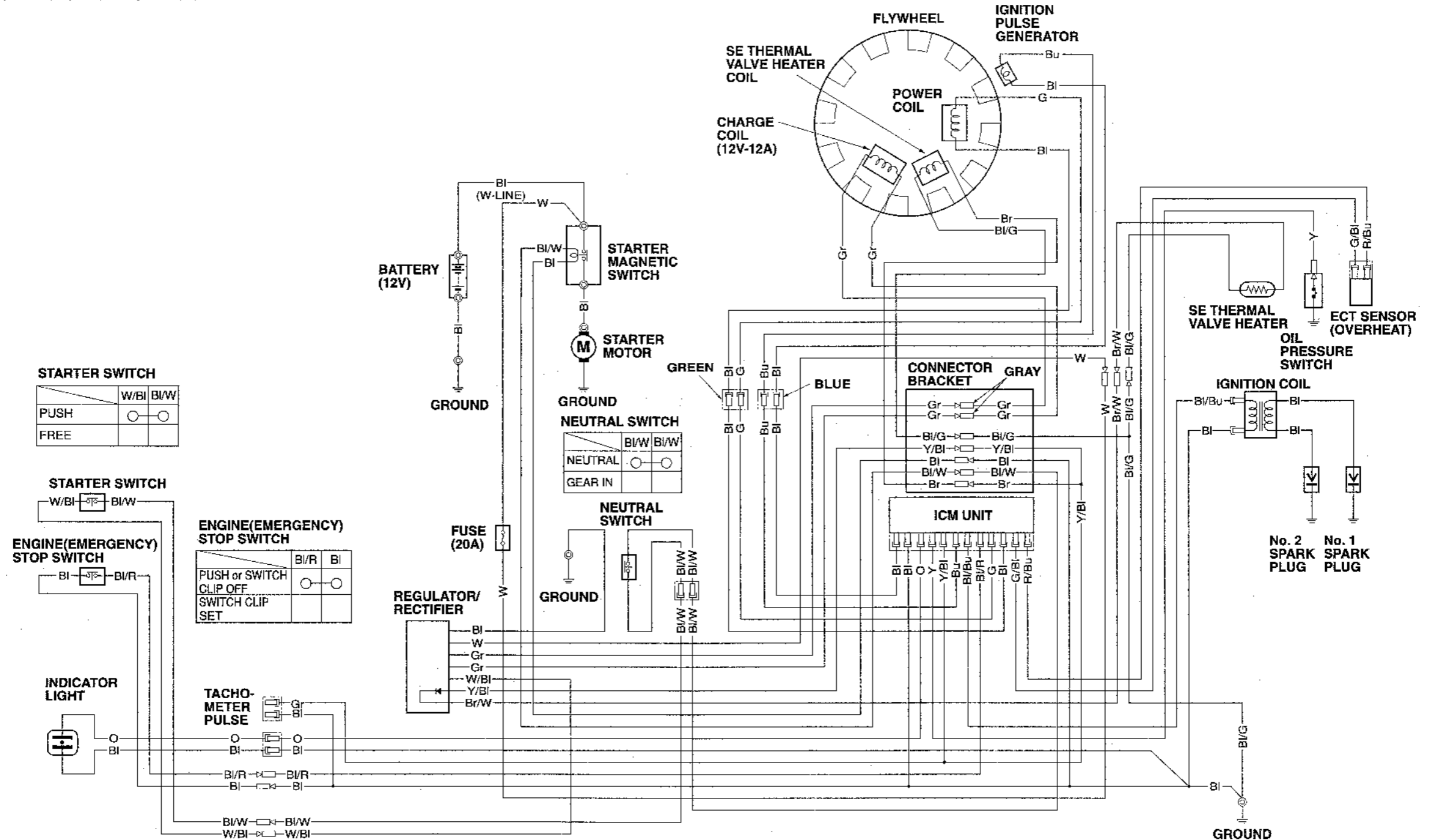

B	BLACK	Br	BROWN
Y	YELLOW	O	ORANGE
Bu	BLUE	Lb	LIGHT BLUE
G	GREEN	Lg	LIGHT GREEN
R	RED	P	PINK
W	WHITE	Gr	GRAY

# WIRING DIAGRAM

TILLER HANDLE, POWER TILT TYPE (with electric starter type)  
BFP8DD/BFP9.9D models

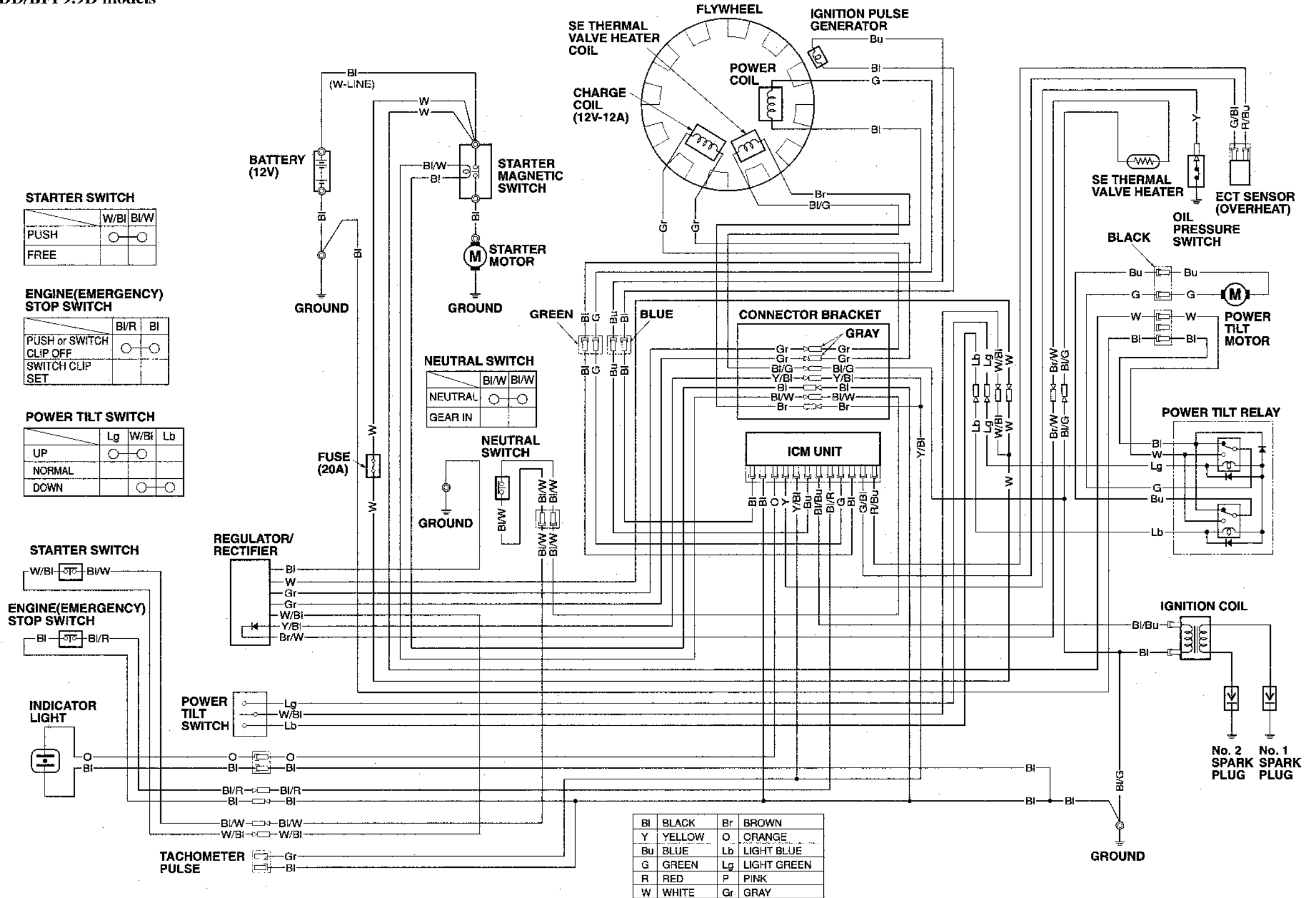

# WIRING DIAGRAM

## REMOTE CONTROL, MANUAL TILT TYPE BF8D/BF9.9D/BFP9.9D models

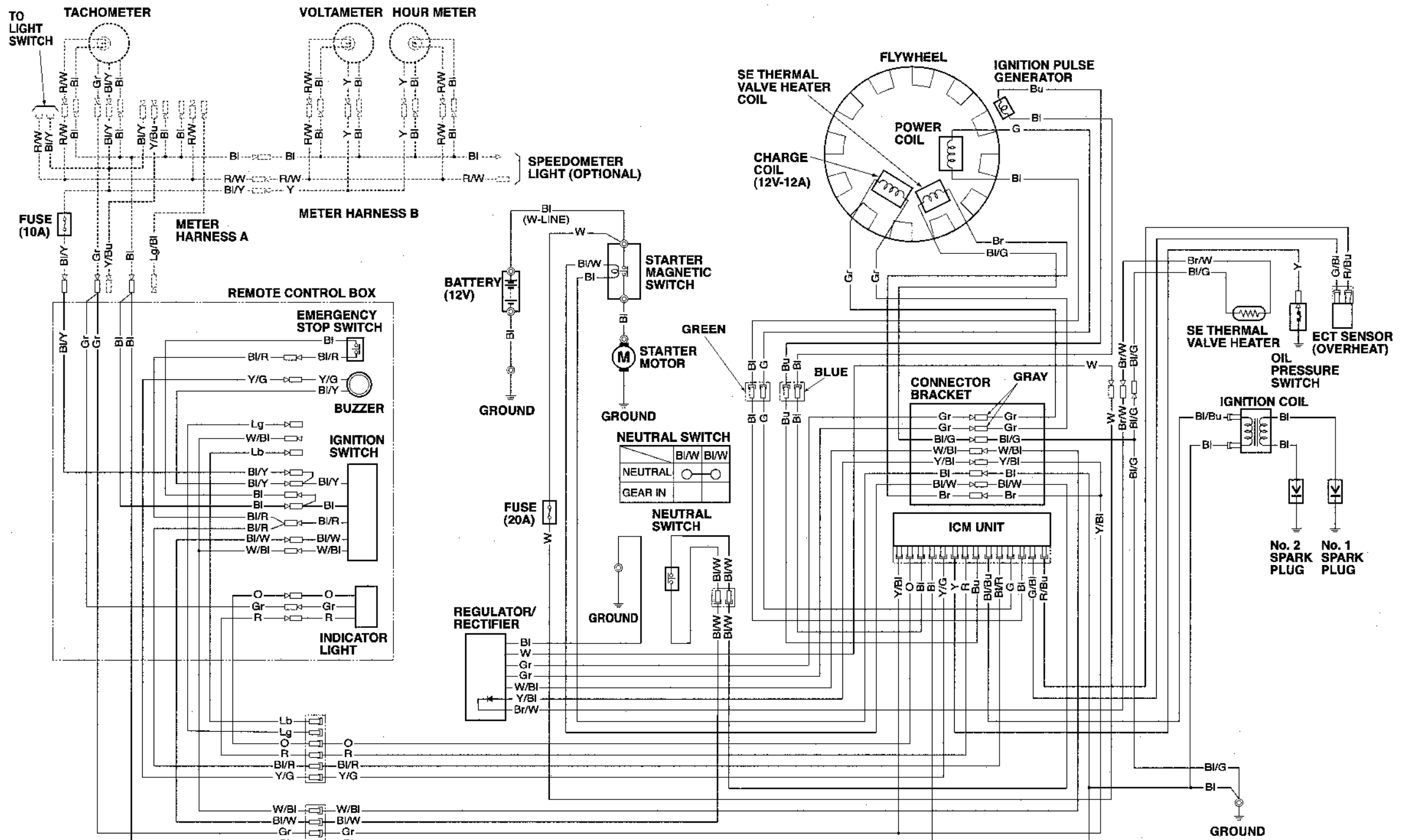

### EMERGENCY STOP SWITCH

	BI/R	BI
PUSH or SWITCH CLIP OFF	<input type="checkbox"/>	<input type="checkbox"/>
SWITCH CLIP SET	<input type="checkbox"/>	<input type="checkbox"/>

### IGNITION SWITCH

	E	IG	BAT	LOAD	ST
COLOR	BI	BI/R	W/BI	BI/Y	BI/W
OFF	<input type="checkbox"/>	<input type="checkbox"/>			
ON			<input type="checkbox"/>	<input type="checkbox"/>	
START			<input type="checkbox"/>	<input type="checkbox"/>	<input type="checkbox"/>

BI	BLACK	Br	BROWN
Y	YELLOW	O	ORANGE
Bu	BLUE	Lb	LIGHT BLUE
G	GREEN	Lg	LIGHT GREEN
R	RED	P	PINK
W	WHITE	Gr	GRAY

# WIRING DIAGRAM

## REMOTE CONTROL, POWER TILT TYPE BFP8D/BFP9.9D models

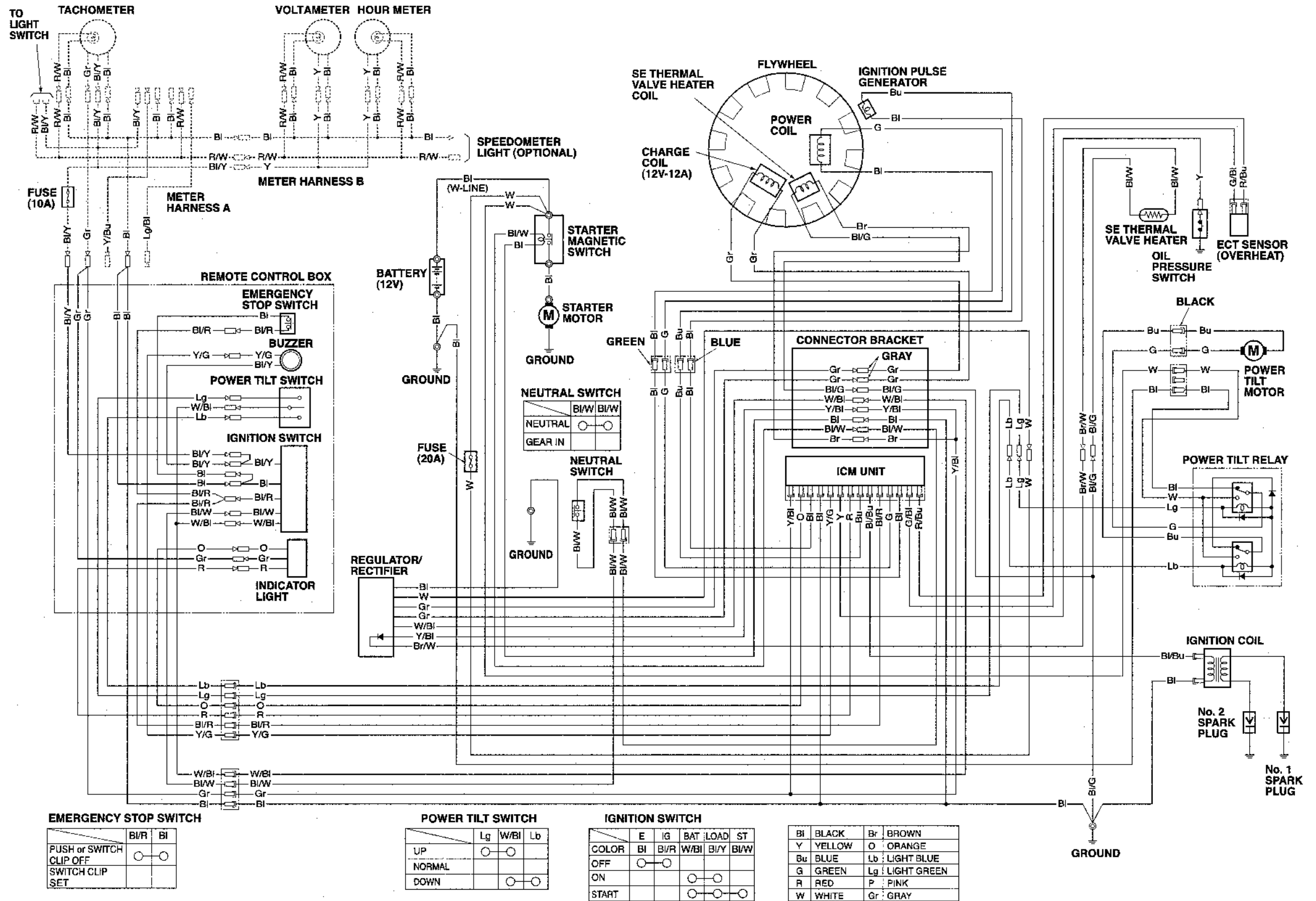

# WIRING DIAGRAM

TILLER HANDLE, MANUAL TILT TYPE and GAS ASSIST TILT TYPE  
 (with recoil starter and 6A charge coil)  
 BF15D/BF20D models

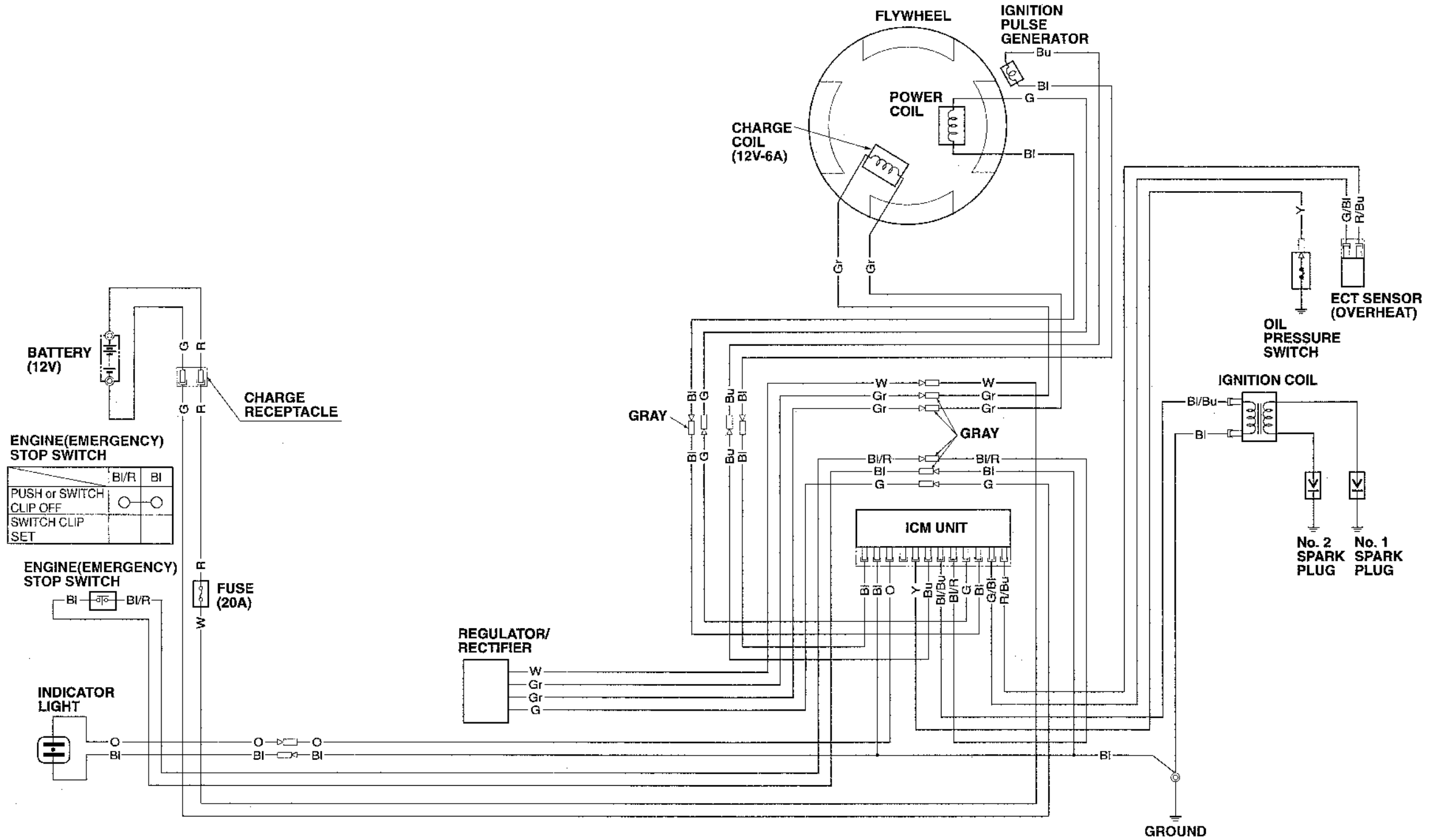

BI	BLACK	Br	BROWN
Y	YELLOW	O	ORANGE
Bu	BLUE	Lb	LIGHT BLUE
G	GREEN	Lg	LIGHT GREEN
R	RED	P	PINK
W	WHITE	Gr	GRAY



# WIRING DIAGRAM

TILLER HANDLE, MANUAL TILT TYPE and GAS ASSIST TILT TYPE  
(with electric starter type)  
BF15D/BF20D models

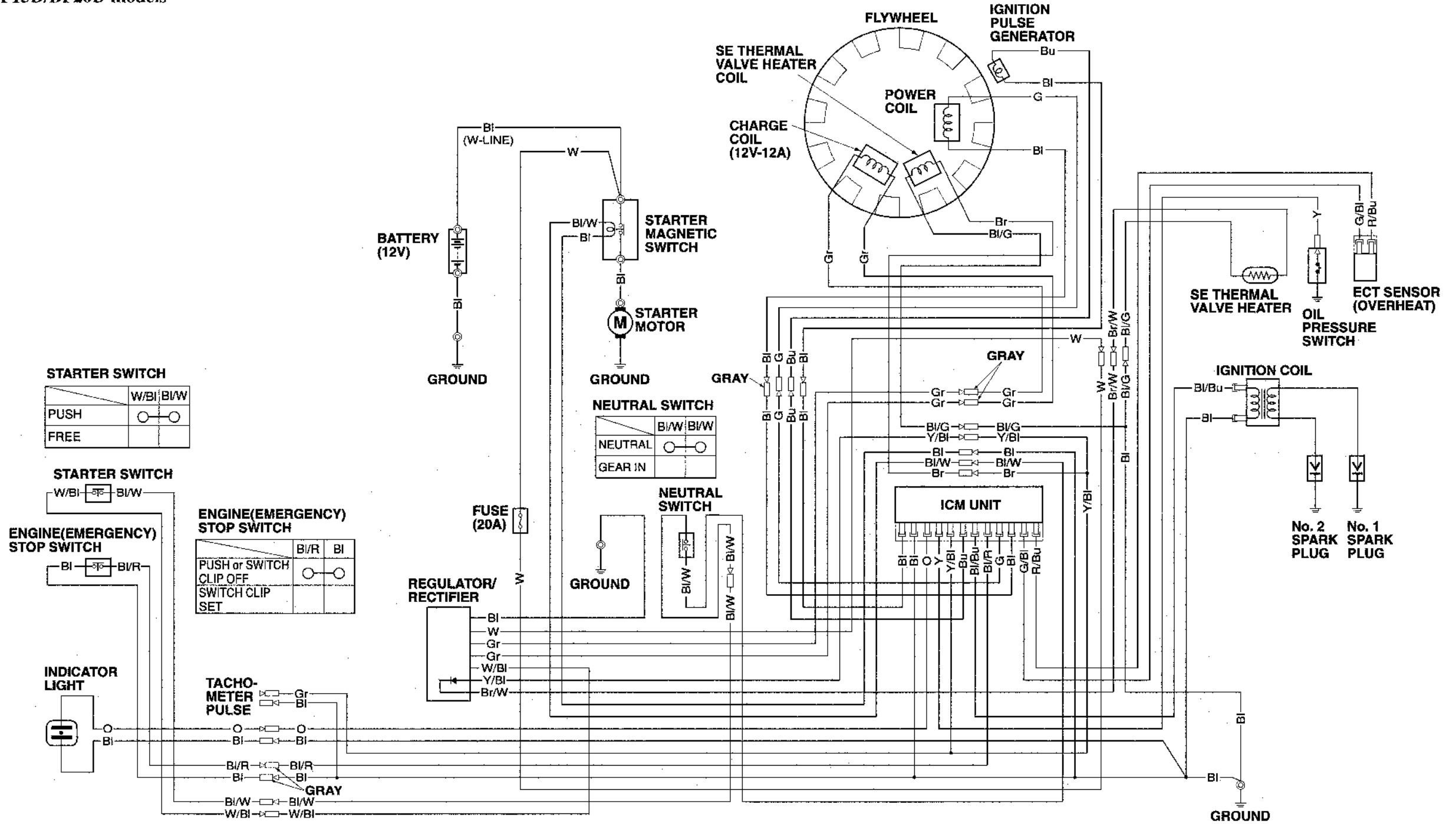

BI	BLACK	Br	BROWN
Y	YELLOW	O	ORANGE
Bu	BLUE	Lb	LIGHT BLUE
G	GREEN	Lg	LIGHT GREEN
R	RED	P	PINK
W	WHITE	Gr	GRAY

# WIRING DIAGRAM

TILLER HANDLE, POWER TILT TYPE (with electric starter type)  
BF15D/BFP15D/BF20D models

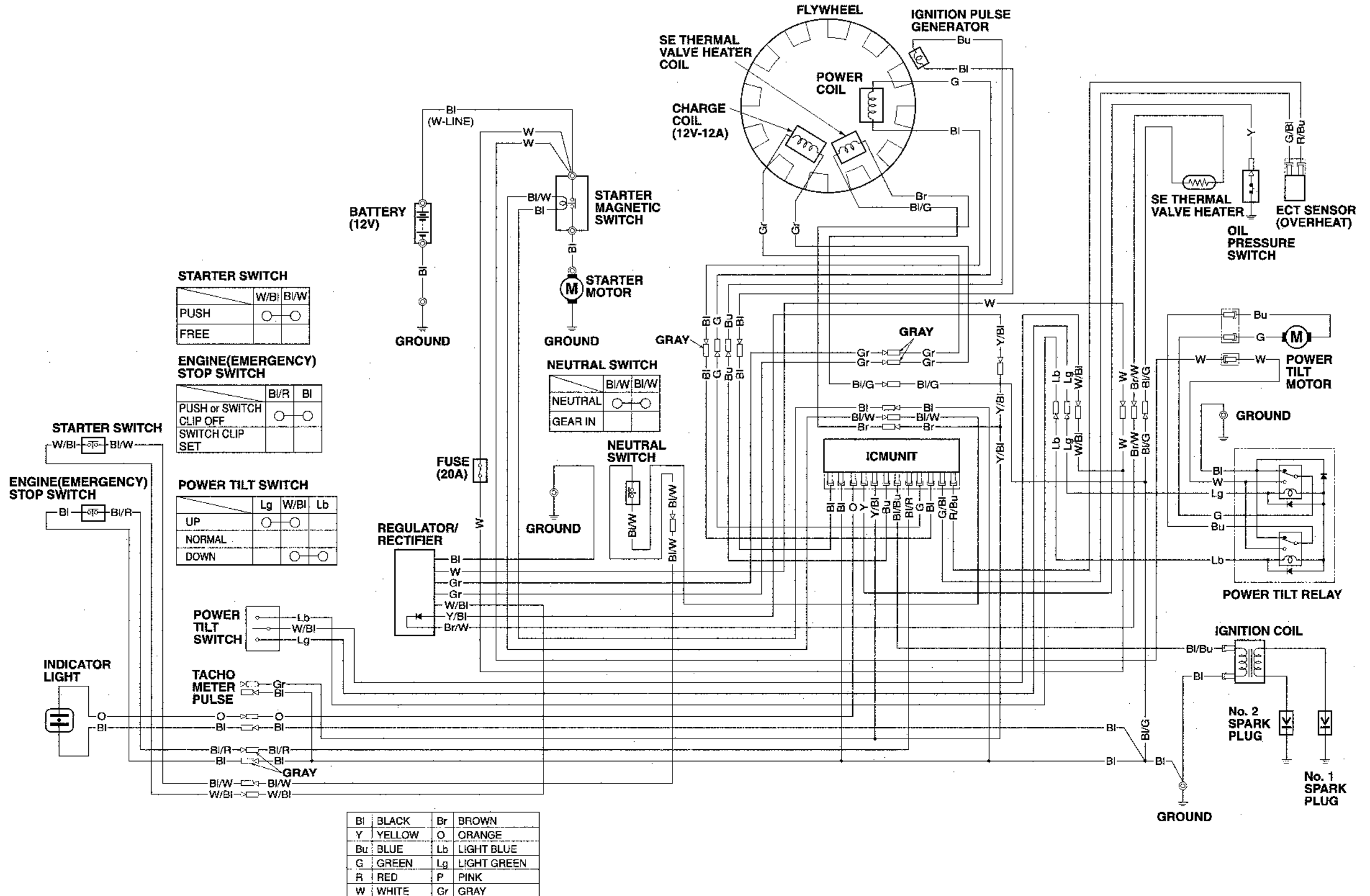

# WIRING DIAGRAM

REMOTE CONTROL, MANUAL TILT TYPE  
BF15D/BF20D models

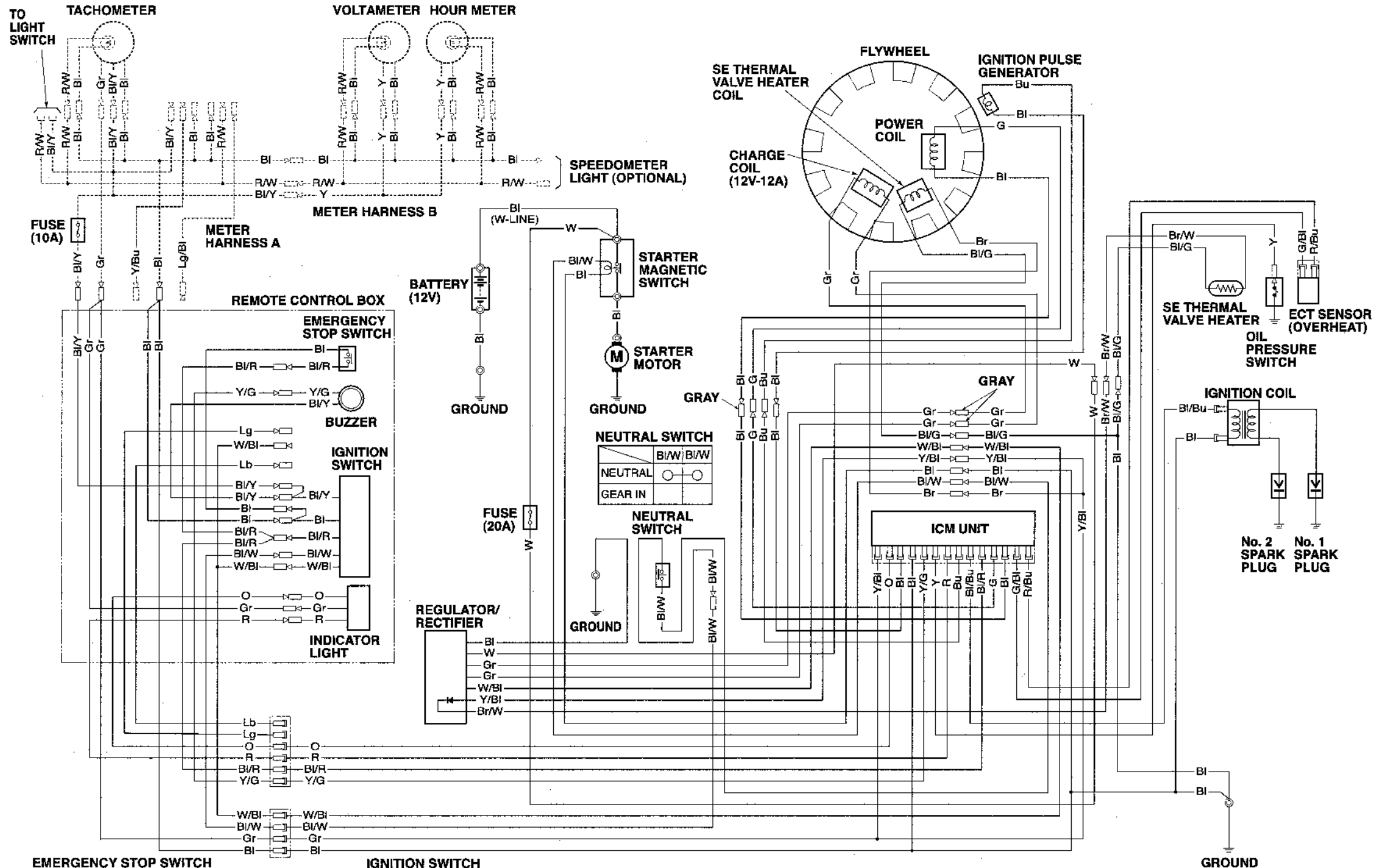

EMERGENCY STOP SWITCH

	BI/R	BI
PUSH or SWITCH	○	○
CLIP OFF		
SWITCH CLIP		
SET		

IGNITION SWITCH

	E	IG	BAT	LOAD	ST
COLOR	BI	BI/R	W/BI	BI/Y	BI/W
OFF	○	○			
ON			○	○	
START			○	○	○

BI	BLACK	Br	BROWN
Y	YELLOW	O	ORANGE
Bu	BLUE	Lb	LIGHT BLUE
G	GREEN	Lg	LIGHT GREEN
R	RED	P	PINK
W	WHITE	Gr	GRAY

# WIRING DIAGRAM

REMOTE CONTROL, POWER TILT TYPE  
BF15D/BFP15D/BF20D/BFP20D models

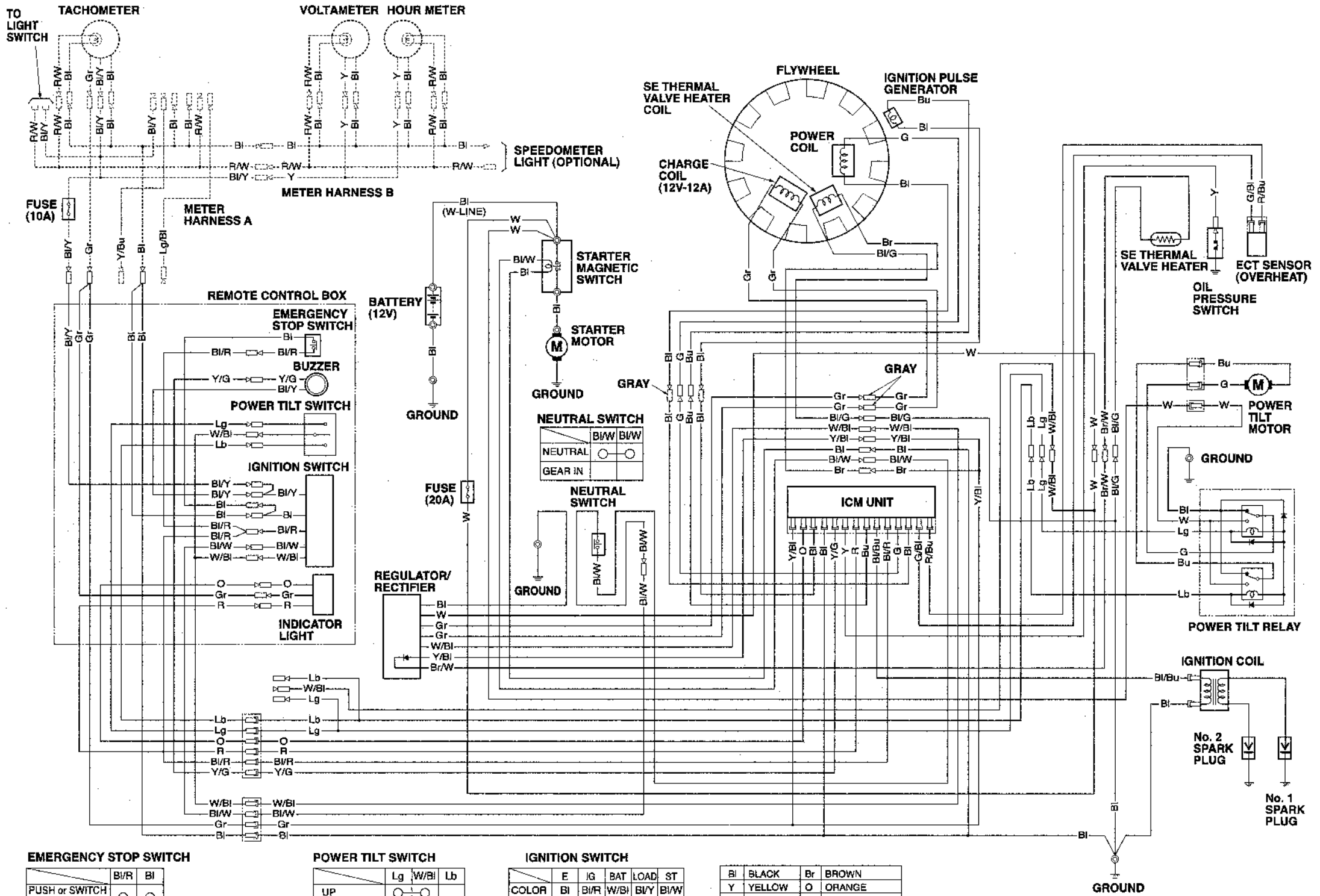

**EMERGENCY STOP SWITCH**

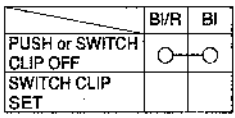

**POWER TILT SWITCH**

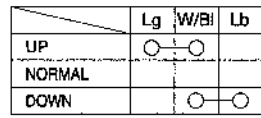

**IGNITION SWITCH**

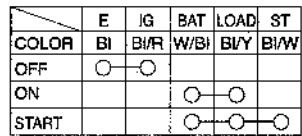

BI	BLACK	Br	BROWN
Y	YELLOW	O	ORANGE
Bu	BLUE	Lb	LIGHT BLUE
G	GREEN	Lg	LIGHT GREEN
R	RED	P	PINK
W	WHITE	Gr	GRAY

# HONDA

The Power of Dreams

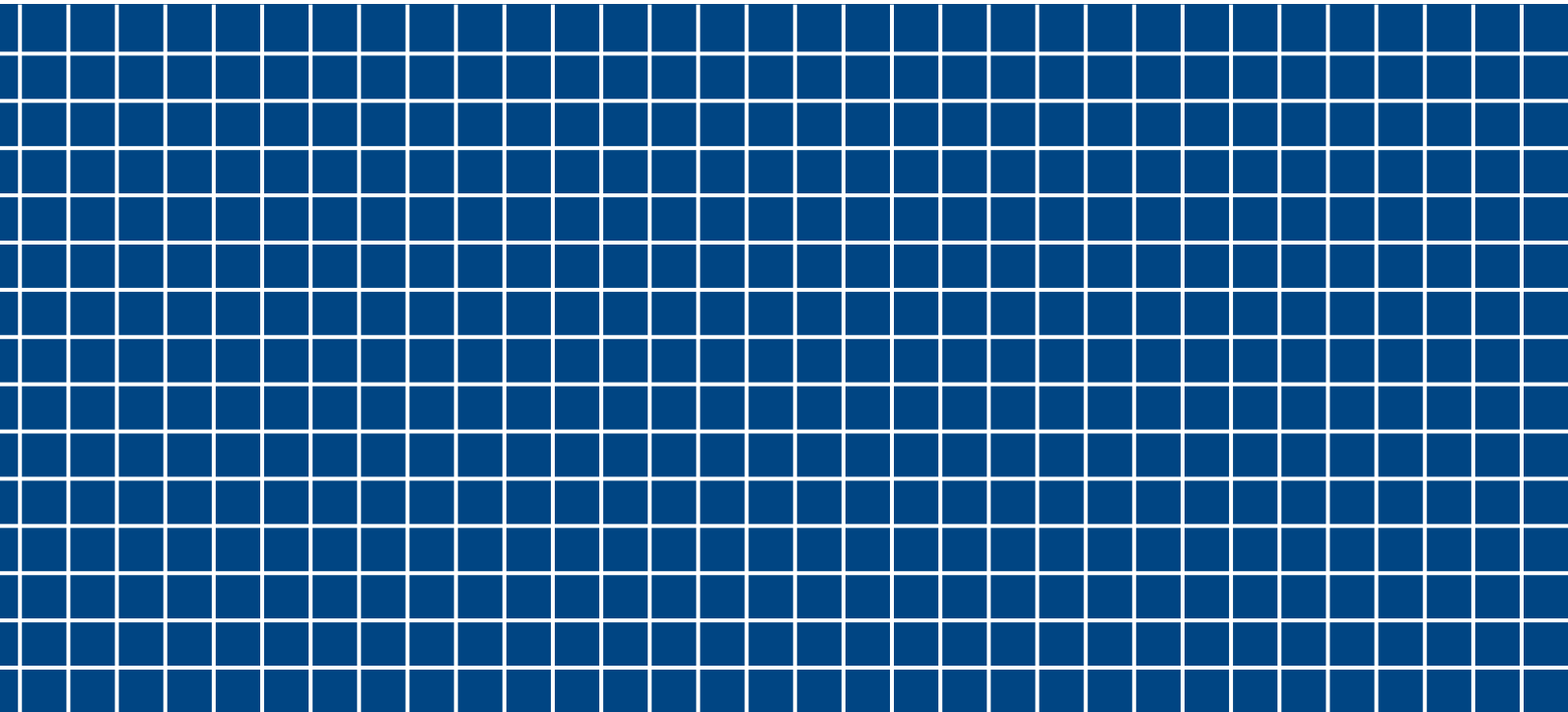

31ZY0608  
00X31-ZY0-6080



(AH) (英) (C) (HC) 2000.2005.10

Printed in Japan