

**HONDA**  
**MARINE**

**BF5A**  
**Owner's Manual**

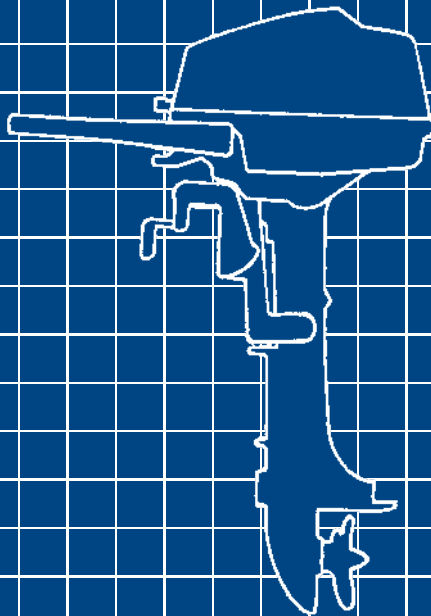



## **WARNING:**



The engine exhaust from this product contains chemicals known to the State of California to cause cancer, birth defects, or other reproductive harm.

Keep this owner's manual handy, so you can refer to it at any time. This owner's manual is considered a permanent part of the outboard motor and should remain with the outboard motor if resold.

The information and specifications included in this publication were in effect at the time of approval for printing. Honda Motor Co., Ltd. reserves the right, however, to discontinue or change specifications or design at any time without notice and without incurring any obligation whatever. No part of this publication may be reproduced without written permission.

# INTRODUCTION

Congratulations on your selection of a Honda outboard motor. We are certain you will be pleased with your purchase of one of the finest outboard motors on the market.

We want to help you get the best results from your new outboard motor and to operate it safely. This manual contains the information on how to do that; please read it carefully.

As you read this manual you will find information preceded by a

**NOTICE** symbol. That information is intended to help you avoid damage to your outboard motor, other property, or the environment.

We suggest you read the warranty policy to fully understand its coverage and your responsibilities of ownership. The warranty policy is a separate document that should have been given to you by your dealer.

When your outboard motor needs scheduled maintenance, keep in mind that your Honda marine dealer is specially trained in servicing Honda outboard motors. Your Honda marine dealer is dedicated to your satisfaction and will be pleased to answer your questions and concerns.

© 2003 Honda Motor Co., Ltd. All Rights Reserved

# INTRODUCTION

---

## A FEW WORDS ABOUT SAFETY

Your safety and the safety of others are very important. And using this outboard motor safely is an important responsibility.



To help you make informed decisions about safety, we have provided operating procedures and other information on labels and in this manual. This information alerts you to potential hazards that could hurt you or others.

Of course, it is not practical or possible to warn you about all the hazards associated with operating or maintaining an outboard motor. You must use your own good judgment.

You will find important safety information in a variety of forms, including:

- **Safety Labels** — on the outboard motor.
- **Safety Messages** — preceded by a safety alert symbol  and one of three signal words, DANGER, WARNING, or CAUTION.

These signal words mean:

- |   |   |
|---|---|
|  | You <b>WILL</b> be <b>KILLED</b> or <b>SERIOUSLY HURT</b> if you don't follow instructions. |
|  | You <b>CAN</b> be <b>KILLED</b> or <b>SERIOUSLY HURT</b> if you don't follow instructions.  |
|  | You <b>CAN</b> be <b>HURT</b> if you don't follow instructions.                             |

- **Safety Headings** — such as *IMPORTANT SAFETY INFORMATION*.
- **Safety Section** — such as *OUTBOARD MOTOR SAFETY*.
- **Instructions** — how to use this outboard motor correctly and safely.

This entire book is filled with important safety information — please read it carefully.

# CONTENTS

OUTBOARD MOTOR SAFETY.....	6	INDICATORS.....	16
IMPORTANT SAFETY INFORMATION.....	6	Oil Pressure Indicator.....	16
SAFETY LABEL LOCATIONS.....	8	Cooling System Indicator.....	16
CONTROLS AND FEATURES.....	9	OTHER FEATURES.....	16
CONTROL AND FEATURE		Overrev Limiter.....	16
IDENTIFICATION CODES.....	9	Anode.....	17
COMPONENT AND CONTROL LOCATIONS.....	10	Portable Fuel Tank.....	17
CONTROLS.....	12	Fuel Cap Vent Knob.....	17
Engine Stop Switch and Switch Clip.....	12	Fuel Priming Bulb.....	18
Choke Knob.....	12	INSTALLATION.....	19
Throttle Grip.....	13	POWER REQUIREMENTS.....	19
Throttle Friction Knob.....	13	INSTALLATION POSITION.....	19
Gearshift Lever.....	13	ATTACHMENT.....	20
Recoil Starter Grip.....	14	TRANSOM ANGLE ADJUSTMENT.....	20
Engine Cover Lock Lever.....	14	BEFORE OPERATION.....	21
Transom Angle Adjusting Rod.....	14	ARE YOU READY TO GET UNDER WAY ?.....	21
Steering Friction Bolt.....	15	IS YOUR OUTBOARD MOTOR	
Tilt Lever.....	15	READY TO GO ?.....	21
INSTRUMENTS.....	15		
Fuel Gauge.....	15		

# CONTENTS

---

OPERATION .....	23	SERVICING YOUR OUTBOARD MOTOR.....	36
SAFE OPERATING PRECAUTIONS .....	23	THE IMPORTANCE OF MAINTENANCE .....	36
BREAK-IN PROCEDURE.....	23	MAINTENANCE SAFETY .....	37
TRANSOM ANGLE ADJUSTMENT .....	23	TOOL KIT AND EMERGENCY STARTER	
PORTABLE FUEL TANK.....	24	ROPE.....	38
FUEL HOSE CONNECTIONS.....	24	MAINTENANCE SCHEDULE .....	39
FUEL PRIMING.....	25	ENGINE COVER REMOVAL AND	
STARTING THE ENGINE .....	25	INSTALLATION.....	41
EMERGENCY STARTING.....	27	Engine Oil Level Check .....	41
STOPPING THE ENGINE.....	30	Engine Oil Change .....	42
Emergency Engine Stopping .....	30	Engine Oil Recommendations .....	43
Normal Engine Stopping.....	30	Lubrication Points .....	44
GEARSHIFTING AND		Spark Plug Service .....	45
THROTTLE OPERATION .....	31	REFUELING.....	47
STEERING .....	32	FUEL RECOMMENDATIONS.....	48
CRUISING .....	33	Fuel Pump Filter Inspection and Replacement .....	48
SHALLOW WATER OPERATION .....	34	Portable Fuel Tank and Filter Cleaning .....	50
MOORING, BEACHING, LAUNCHING.....	35	Recoil Starter Rope Inspection .....	51
		Anode Replacement .....	51
		Propeller Replacement .....	52

# CONTENTS

---

STORAGE .....	53	TECHNICAL AND CONSUMER INFORMATION...	68
STORAGE PREPARATION .....	53	TECHNICAL INFORMATION.....	68
Cleaning and Flushing .....	53	Serial Number locations.....	68
Fuel.....	55	Carburetor Modification for High Altitude	
Engine Oil .....	57	Operation.....	69
STORAGE PRECAUTIONS .....	57	Oxygenated Fuels.....	70
REMOVAL FROM STORAGE.....	58	Emission Control System Information .....	71
TRANSPORTING .....	59	Star Label .....	73
WITH OUTBOARD MOTOR INSTALLED		Specifications .....	75
ON BOAT .....	59	CONSUMER INFORMATION .....	76
WITH OUTBOARD MOTOR REMOVED		Honda Publications .....	76
FROM BOAT .....	59	Warranty Service Information .....	76
TAKING CARE OF UNEXPECTED		WIRING DIAGRAM.....	77
PROBLEMS.....	60	INDEX.....	78
ENGINE WILL NOT START.....	60		
HARD STARTING OR STALLS AFTER			
STARTING.....	62		
ENGINE OVERHEATS .....	63		
ENGINE WILL NOT DRIVE THE PROPELLER...	64		
OIL PRESSURE INDICATOR LIGHT GOES OFF			
AND ENGINE SPEED IS LIMITED.....	65		
SUBMERGED MOTOR .....	66		

# OUTBOARD MOTOR SAFETY

## IMPORTANT SAFETY INFORMATION

The Honda BF5A outboard motor is designed for use with boats that have a suitable manufacturer's power recommendation. Other uses can result in injury to the operator or damage to the outboard motor and other property.

Most accidents can be prevented if you follow all instructions in this manual and on the outboard motor. The most common hazards are discussed below, along with the best way to protect yourself and others.

## Operator Responsibility

- It is the operator's responsibility to provide the necessary safeguards to protect people and property. Know how to stop the engine quickly in case of emergency. Understand the use of all controls.
  - Stop the engine immediately if anyone falls overboard, and do not run the engine while the boat is near anyone in the water.
  - Always stop the engine if you must leave the controls for any reason.
- Attach the emergency stop switch lanyard securely to the operator.
  - Always wear a PFD (Personal Flotation Device) while on the boat.
  - Familiarize yourself with all laws and regulations relating to boating and the use of outboard motors.
  - Be sure that anyone who operates the outboard motor receives proper instruction.
  - Be sure the outboard motor is properly mounted on the boat.
  - Do not remove the engine cover while the engine is running.



## Refuel With Care

- Gasoline is extremely flammable, and gasoline vapor can explode. Refuel outdoors, in a well-ventilated area, with the engine stopped. Never smoke near gasoline, and keep other flames and sparks away.
- Remove any portable fuel tank from the boat for refueling. Keep the portable fuel tank away from the battery or other potential spark sources.
- Refuel carefully to avoid spilling fuel. Avoid overfilling the fuel tank.
- After refueling, tighten the filler cap securely. If any fuel is spilled, make sure the area is dry before starting the engine.

## Carbon Monoxide Hazard

Exhaust gas contains poisonous carbon monoxide. Avoid inhalation of exhaust gas. Never run the engine in a closed garage or confined area.

# OUTBOARD MOTOR SAFETY

## SAFETY LABEL LOCATIONS

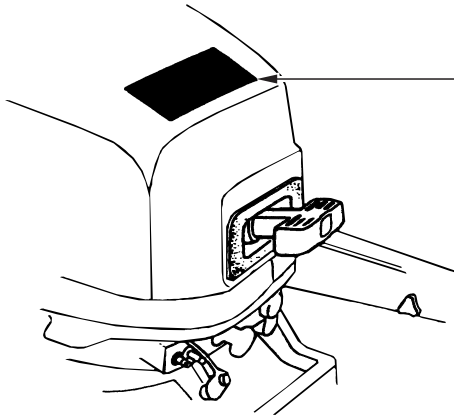

 READ OWNER'S MANUAL CAREFULLY BEFORE OPERATION
<b>⚠ WARNING</b>
<ul style="list-style-type: none"><li>■ PLACE TRANSMISSION IN NEUTRAL BEFORE STARTING.</li><li>■ DO NOT OPERATE WITH ENGINE COVER REMOVED.</li><li>■ BE SURE THE ANTIVENTILATION PLATE IS BELOW THE WATER LINE.</li><li>■ DO NOT SHIFT TO REVERSE SUDDENLY AT HIGH SPEED.</li></ul>
<ul style="list-style-type: none"><li>■ CHECK OIL LEVEL BEFORE STARTING.</li><li>■ FLUSH THE SYSTEM THOROUGHLY WITH FRESH WATER AFTER EACH USE IN SALT WATER.</li></ul>

GASOLINE FLAMMABLE DANGER

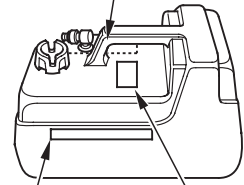

**DANGER**  
HARMFUL OR FATAL IF SWALLOWED.  
KEEP OUT OF REACH OF CHILDREN.  
IF SWALLOWED, DO NOT INDUCE  
VOMITING. CALL A PHYSICIAN  
IMMEDIATELY.

GASOLINE FLAMMABLE DANGER

The labels shown here contain important safety information. Please read them carefully. These labels are considered permanent parts of your outboard motor. If a label comes off or becomes hard to read, contact an authorized Honda Marine servicing dealer for a replacement.

# CONTROLS AND FEATURES

## CONTROL AND FEATURE IDENTIFICATION CODES

Model	BF5A	
Type	SA	LA
Shaft Length	S	L

Refer to this chart for an explanation of the Type Codes used in this manual to identify control and feature applications.

BF5A is provided with the following types according to the shaft length.

- According to Shaft Length  
S: Short Shaft  
L: Long Shaft

(Example)

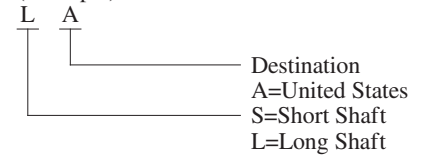

# CONTROLS AND FEATURES

## COMPONENT AND CONTROL LOCATIONS

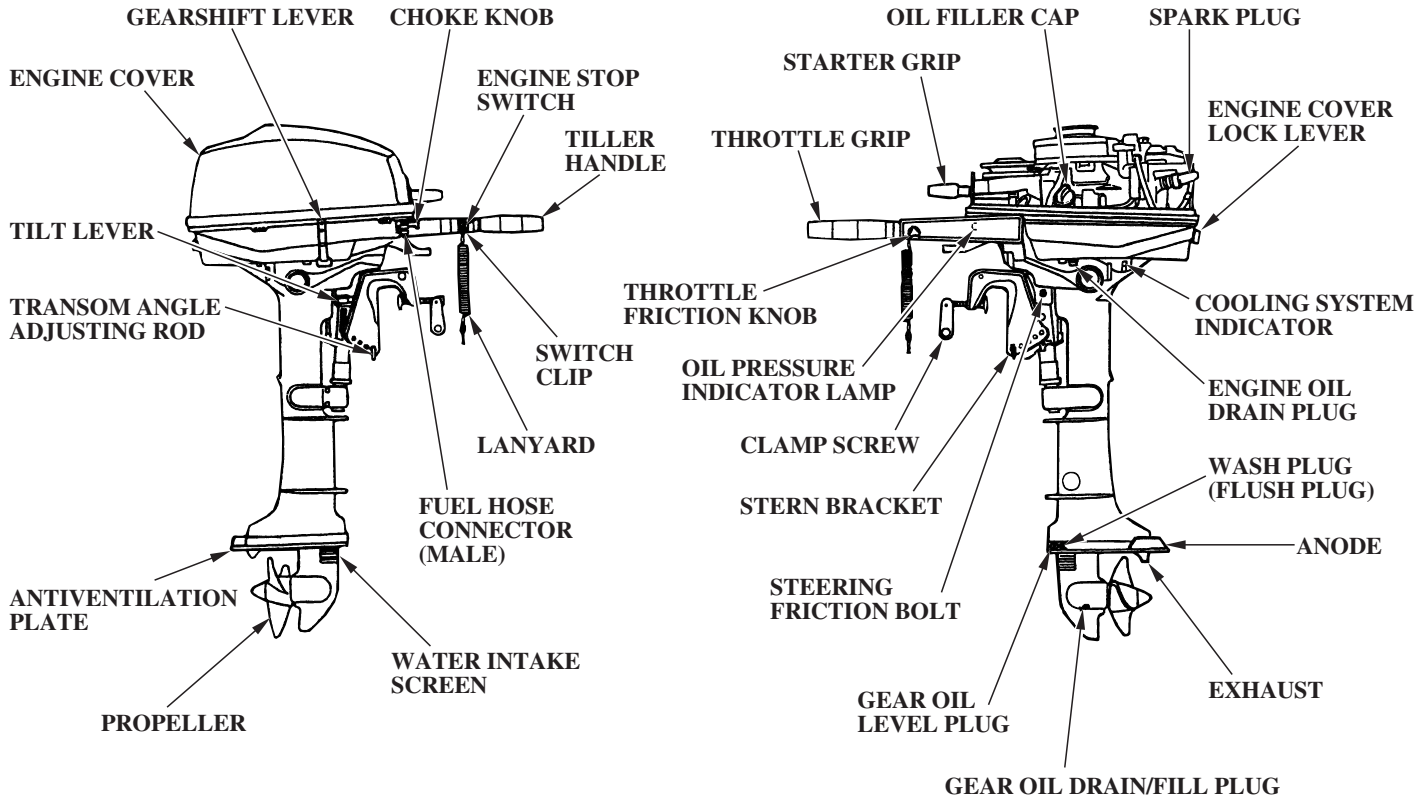

**Fuel Tank**

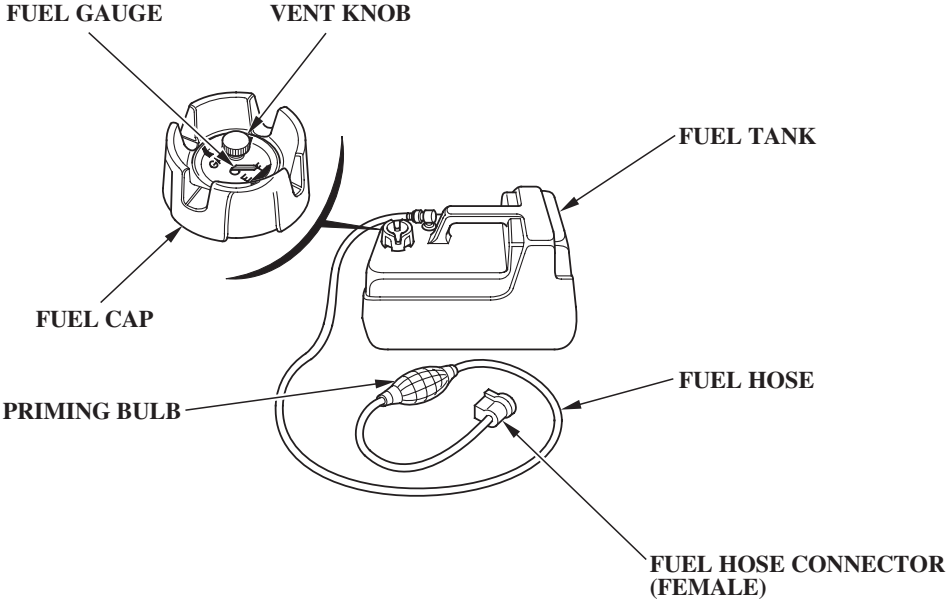

# CONTROLS AND FEATURES

## CONTROLS

### Engine Stop Switch and Switch Clip

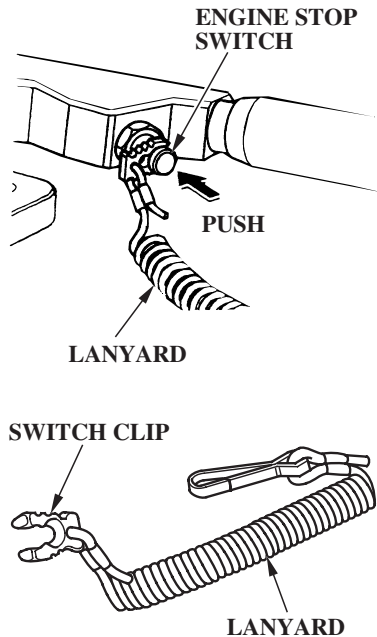

The engine stop switch controls normal engine stopping and emergency engine stopping.

The switch clip must be inserted in the engine stop switch in order for the engine to start and run. The lanyard should be attached to the operator's PFD (Personal Flotation Device) or worn around the wrist.

When used as described, the engine stop switch and lanyard system stops the engine if the operator falls away from the controls.

A spare switch clip is supplied with the tool kit.

## Choke Knob

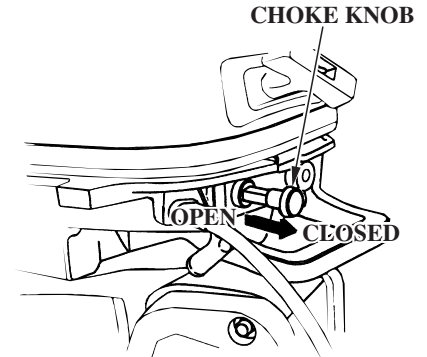

The choke knob opens and closes the choke valve in the carburetor.

The CLOSED position enriches the fuel mixture for starting a cold engine.

The OPEN position provides the correct fuel mixture for operation after starting, and for restarting a warm engine.

**Throttle Grip**

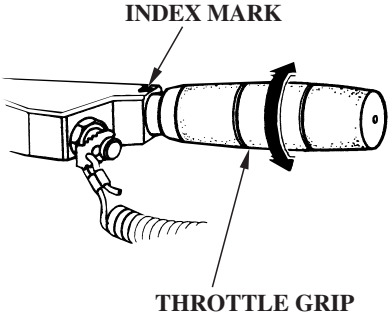

The throttle grip controls engine speed.

An index mark on the tiller handle shows throttle position and is helpful for setting the throttle correctly when starting (p. 26).

**Throttle Friction Knob**

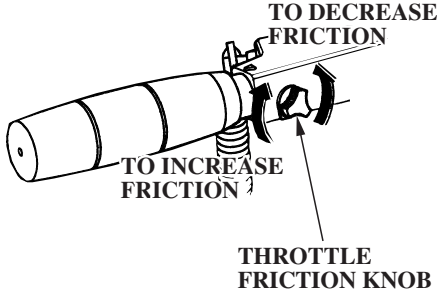

The throttle friction knob adjusts resistance to throttle grip rotation.

Turn the knob clockwise to increase friction for holding a throttle setting while cruising.

Turn the knob counterclockwise to decrease friction for easy throttle grip rotation.

**Gearshift Lever**

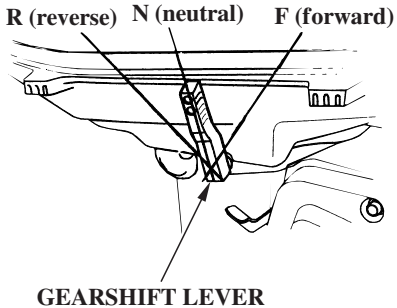

The gearshift lever is used to select F (forward), N (neutral), or R (reverse) gears.

The engine can be started with the gearshift lever in the N (neutral) position only.

If the gearshift lever is in the F (forward) or R (reverse) position, the recoil starter will not operate.

# CONTROLS AND FEATURES

## Recoil Starter Grip

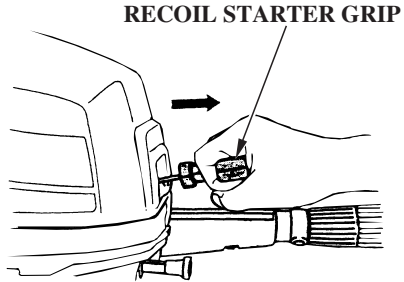

Pull the starter grip to operate the recoil starter for starting the engine manually.

The motor will start only when the gearshift lever (p. 13 ) is in the N (neutral) position, and the clip is in the engine stop switch.

## Engine Cover Lock Lever

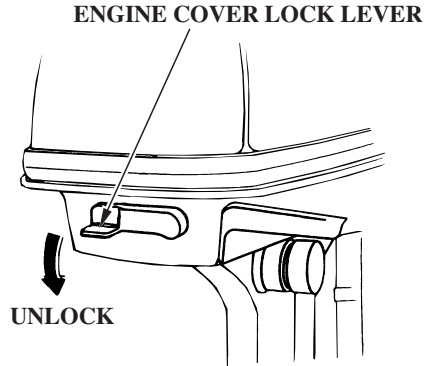

The engine cover lock lever fastens the engine cover to the outboard motor.

## Transom Angle Adjusting Rod

The transom angle adjusting rod adjusts the transom angle of the outboard motor when fully lowered.

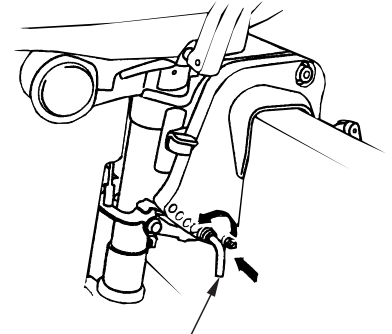

Proper adjustment prevents the outboard motor from being trimmed too low (p. 33 ).



## Steering Friction Bolt

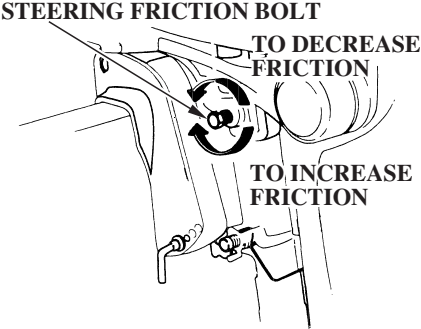

The steering friction bolt adjusts steering resistance.

Less friction allows the outboard motor to turn more easily. More friction helps to hold steady course while cruising or to prevent the outboard motor from swinging while trailering the boat.

## Tilt Lever

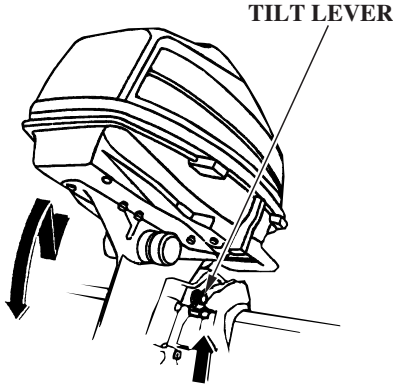

The tilt lever enables the outboard motor to be raised for shallow water operation, beaching, launching, or mooring.

To tilt, raise the outboard motor by pulling on the cover grip until the tilt mechanism engages at 30°, 45°, or 70° (p. 34).

## INSTRUMENTS

### Fuel Gauge

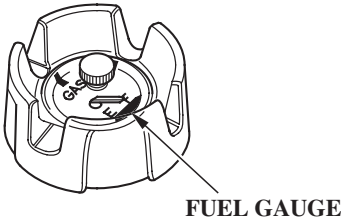

A fuel gauge is built into the cap of the portable fuel tank.

# CONTROLS AND FEATURES

---

## INDICATORS

### Oil Pressure Indicator

#### OIL PRESSURE INDICATOR LIGHT

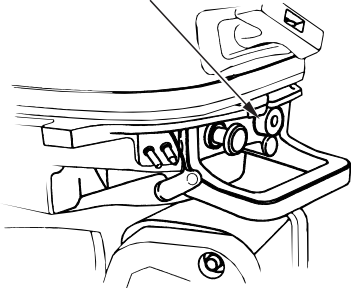

When the green light is lit, oil pressure is OK.

If oil pressure becomes low, the green light will go off.

Low oil pressure indicates that the engine oil level is low, or that there is a problem with the engine lubrication system.

### Cooling System Indicator

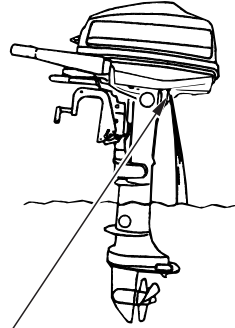

#### COOLING SYSTEM INDICATOR

Water should flow from the cooling system indicator while the engine is running. This shows that water is circulating through the cooling system.

If water stops flowing while the engine is running, that indicates a cooling system problem, such as clogged water intakes, which will cause engine overheating.

## OTHER FEATURES

### Overrev Limiter

The engine is equipped with an overrev limiter to prevent the possibility of mechanical damage from excessive engine speed.

The overrev limiter may be activated during operation, limiting engine speed, if the outboard motor is tilted excessively, or when propeller ventilation occurs during a sharp turn.

If the overrev limiter is activated, check the tilt angle of the outboard motor.

## Anode

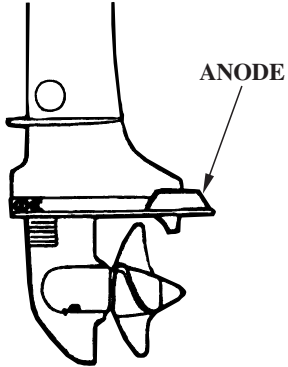

The anode is made of a sacrificial material that helps to protect the outboard motor from corrosion.

There is an anode on the antiventilation plate.

## Portable Fuel Tank

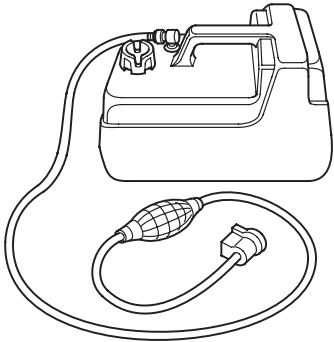

The portable fuel tank has a capacity of 3.2 US gal (12 ℓ ) and has a fuel gauge built into the cap.

## Fuel Cap Vent Knob

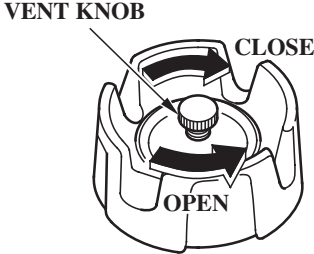

The cap is provided with a vent knob to seal the portable fuel tank for carrying it to and from the boat. Open the vent knob 2 or 3 turns before starting the engine (p. 24).

# CONTROLS AND FEATURES

---

## Fuel Priming Bulb

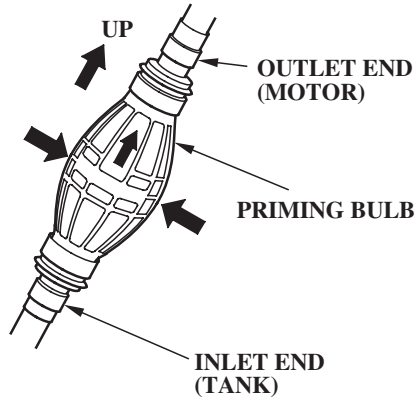

A priming bulb is built into the fuel hose that connects the fuel tank to the outboard motor.

Before starting the engine, hold the priming bulb up in the direction of the arrow, then squeeze the priming bulb until it feels firm. This will ensure that fuel is supplied to the engine (p. 25).

# INSTALLATION

Correct and secure installation is essential for safe boating and good performance. Follow the installation instructions provided in this manual.

## POWER REQUIREMENTS

Before installation, check to be sure that the outboard motor does not exceed the recommended maximum horsepower for the boat on which it is to be installed. Refer to the boat's certification plate for recommended maximum horsepower. If the certification plate information is not available, contact the boat dealer or manufacturer.

For most applications, the outboard motor should have a horsepower rating which provides 80% of the maximum recommended horsepower for the boat.

## INSTALLATION POSITION

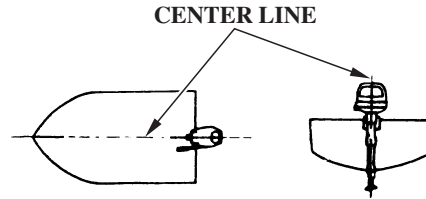

Install the outboard motor on the center of the boat transom.

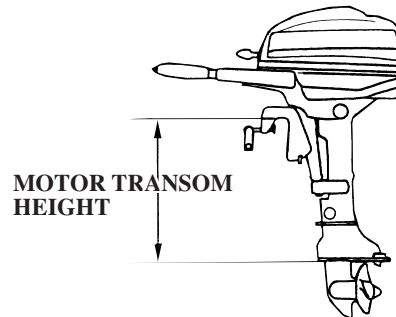

Type:	Motor Transom Height
S:	17.5 in (445 mm)
L:	22.5 in (572 mm)

The antiventilation plate of the outboard motor should be 0 – 2.0 inches below the bottom of the boat. With the boat in the water and loaded, the antiventilation plate should be about 3.9 inches below the surface of the water.

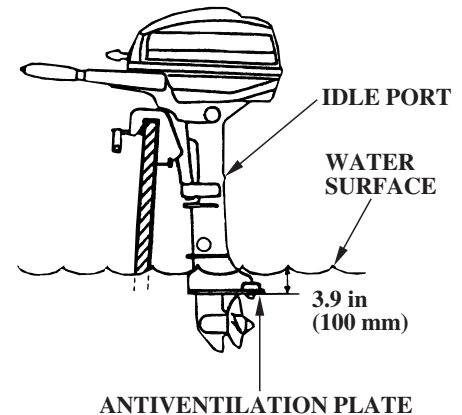

## INSTALLATION

---

When the outboard motor is installed extremely low, the idle port may be immersed and the engine may become hard to start or may run poorly. Check that the idle port is high enough from the water level when the engine is stopped with the boat fully loaded.

If the outboard motor is installed too high, that will cause ventilation.

Optimum installation height varies with boat type and bottom shape. Contact the boat manufacturer for any special recommendations that are unique to a specific model of boat.

If the transom needs to be modified to accommodate the outboard motor, contact the boat manufacturer and follow their recommendations for corrective action.

### ATTACHMENT

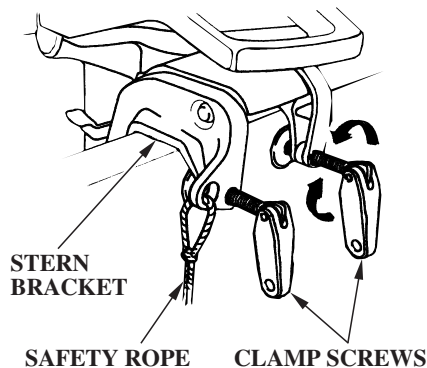

Attach the stern bracket to the boat transom by tightening the clamp screws.

Attach a rope from the boat to the hole in the stern bracket. This will help to prevent accidental loss of the outboard motor.

### TRANSOM ANGLE ADJUSTMENT

Use the transom angle adjustment rod (p. 23 ) to adjust the angle of the outboard motor so the propeller is perpendicular to the surface of the water.

## ARE YOU READY TO GET UNDER WAY ?

Your safety is your responsibility. A little time spent in preparation will significantly reduce your risk of injury.

### Knowledge

Read and understand this manual. Know what the controls do and how to operate them.

Familiarize yourself with the outboard motor and its operation before you get under way. Know what to do in case of emergencies.

Familiarize yourself with all laws and regulations relating to boating and the use of outboard motors.

### Safety

Always wear a PFD (Personal Flotation Device) while on the boat.

Attach the emergency stop switch lanyard securely to your PFD or to your wrist.

## IS YOUR OUTBOARD MOTOR READY TO GO ?

For your safety, and to maximize the service life of your equipment, it is very important to take a few moments before you operate the outboard motor to check its condition. Be sure to take care of any problem you find, or have your authorized Honda Marine dealer correct it, before you operate the outboard motor.

## BEFORE OPERATION

### WARNING

Improperly maintaining this outboard motor, or failing to correct a problem before operation, could cause a malfunction in which you could be seriously injured.

Always perform a preoperation inspection before each operation, and correct any problem.

Before beginning your preoperation checks, be sure the switch clip is removed from the engine stop switch.

# BEFORE OPERATION

---

## Safety Inspection

- Look around the outboard motor for signs of oil or gasoline leaks.
- If you are using the portable fuel tank, make sure it is in good condition and properly secured in the boat (p. 24).
- Check that the fuel hose is undamaged and properly connected (p. 24).
- Wipe up any spills before starting the engine.
- Check the stern bracket to be sure the outboard motor is securely installed.
- Check that all controls are operating properly.
- Replace any damaged parts.
- Check that all fasteners are in place and securely tightened.

## Maintenance Inspection

- Check the engine oil level (p. 41). Running the engine with a low oil level can cause engine damage.
- Check to be sure the propeller is undamaged (p. 52).
- Check that the anode is securely attached to the antiventilation plate (p. 51) and is not excessively worn. The anode helps to protect the outboard motor from corrosion.
- Make sure the tool kit and emergency starter rope are onboard (p. 38). Replace any missing items.
- Check the fuel level in the fuel tank (p. 47).



# OPERATION

## SAFE OPERATING PRECAUTIONS

To safely realize the full potential of this outboard motor, you need a complete understanding of its operation and a certain amount of practice with its controls.

Before operating the outboard motor for the first time, please review the *IMPORTANT SAFETY INFORMATION* on page 6 and the chapter titled *BEFORE OPERATION*.

For your safety, avoid starting or operating the engine in an enclosed area. Your engine's exhaust contains poisonous carbon monoxide gas which can collect rapidly in an enclosed area and cause illness or death.

## BREAK-IN PROCEDURE

Proper break-in procedure allows the moving parts to wear in smoothly for best performance and long service life.

For the first 10 hours, run the outboard motor at low speed, and avoid full-throttle operation.

## TRANSOM ANGLE ADJUSTMENT

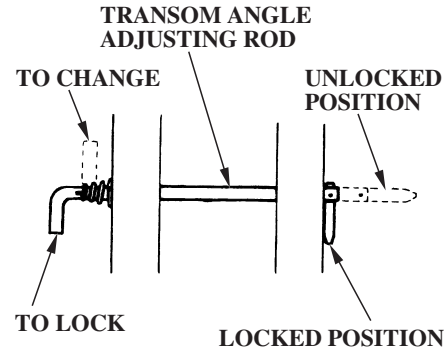

The transom angle adjusting rod is used to adjust the angle of the outboard motor in the normal operating position (p. 33).

To adjust, first tilt the outboard motor so it is not resting on the rod.

Push the rod in and turn the end of the rod up, so the latch will fall into line with the rod.

Remove the rod and reinsert it in the desired position.

Push the rod in and turn the end of the rod down, so the latch will fall to the locked position. Then release the rod.

# OPERATION

## PORTABLE FUEL TANK

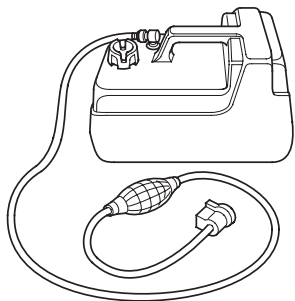

Place the portable fuel tank in a well-ventilated location, away from direct sunlight, to reduce the possibility of a gasoline vapor explosion.

To ensure that the outboard motor will be able to draw fuel from the tank, place the tank within 6 feet of the outboard motor and not more than 3 feet below the fuel connector on the outboard motor.

Secure the portable fuel tank in the boat, so it won't move around and become damaged.

Before use, open the fuel tank vent by turning the vent knob at least 2 or 3 turns counterclockwise.

### **⚠ WARNING**

Gasoline is highly flammable and explosive.

You can be burned or seriously injured when handling fuel.

- Stop the engine and keep heat, sparks, and flame away.
- Handle fuel only outdoors.
- Wipe up spills immediately.

## FUEL HOSE CONNECTIONS

### FUEL HOSE CONNECTOR

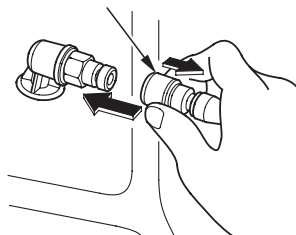

(FUEL TANK SIDE)

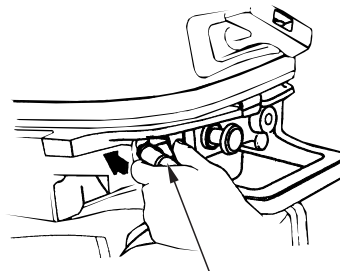

FUEL HOSE CONNECTOR

(OUTBOARD MOTOR SIDE)

Connect the fuel hose to the tank and the outboard motor, as shown. Be sure both connectors snap securely into place.

**FUEL PRIMING**

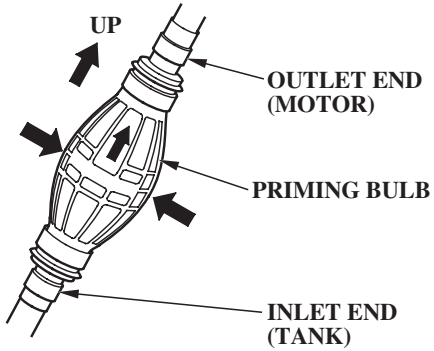

Hold the priming bulb up in the direction of the arrow, then squeeze the priming bulb several times until it feels firm, indicating that fuel has reached the engine.

Check to be sure there are no fuel leaks before starting the engine.

Do not squeeze the priming bulb when the engine is running because that could flood the carburetors.

**STARTING THE ENGINE**

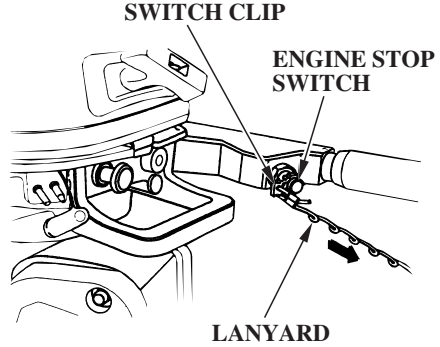

1. Put the emergency stop switch clip in the engine stop switch, and attach the lanyard to your PFD (Personal Flotation Device) or to your wrist.

The engine will not start or run, unless the clip is in the switch.

The emergency stop switch clip and lanyard system is a safety device that will stop the engine if you fall away from the controls while operating the boat.

Always attach the lanyard to your PFD, or to your wrist, before starting the engine.

## OPERATION

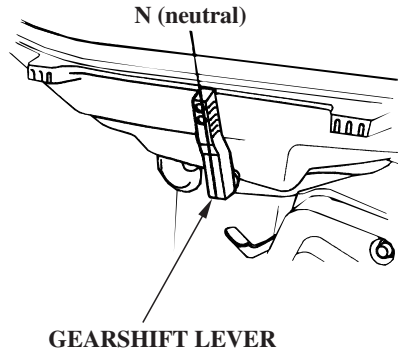

2. Check the position of the gearshift lever. It must be in the N (neutral) position for starting.

The engine will not start if the gearshift lever is in the F (forward) or R (reverse) position.

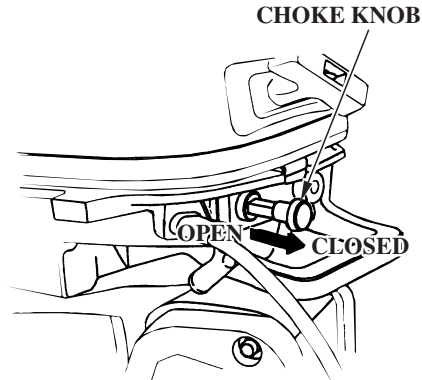

3. To start a cold engine, pull the choke knob to the CLOSED position. To restart a warm engine, leave the choke knob in the OPEN position.

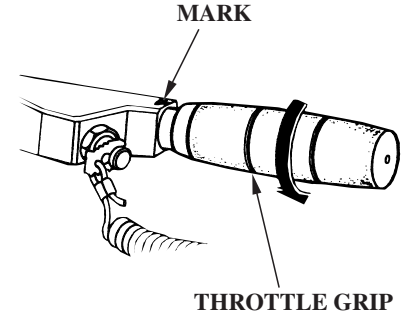

4. Align the START position with the mark for starting the engine.

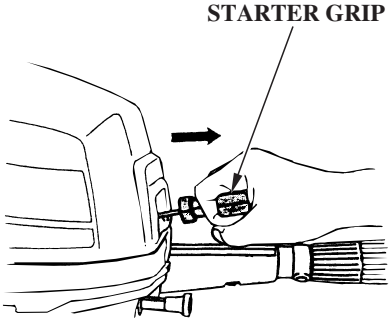

5. Pull the recoil starter grip slowly until you feel resistance, then pull briskly.

Return the starter grip gently.

6. If the choke knob was pulled to the CLOSED position to start the engine, gradually push it to the OPEN position as the engine warms up.

Also, as the engine warms up, the throttle grip can be turned to the SLOW position without stalling.

7. Before getting under way, allow the engine to warm up sufficiently to ensure good performance.

During the warm-up period, check the oil pressure indicator (p. 16) and cooling system indicator (p. 16).

If the indicators show any abnormal condition, immediately stop the engine and determine the cause of the problem. Refer to *TAKING CARE OF UNEXPECTED PROBLEMS*, p. 60.

**EMERGENCY STARTING**

If the recoil starter is inoperative, you can start the engine manually using the emergency starter rope supplied with the tool kit.

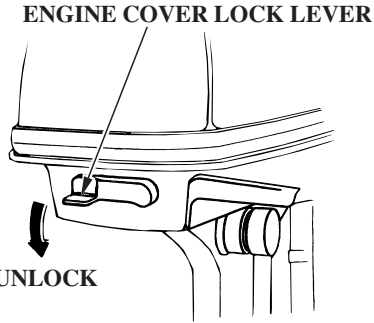

1. Unlock and remove the engine cover.

## OPERATION

---

2. Set the controls the same as for normal starting (see pages 25 — 27 ). Use the choke control if needed.

3. Set the knotted end of the emergency starter rope in the notch in the flywheel. Wind the rope clockwise around the flywheel, as shown.

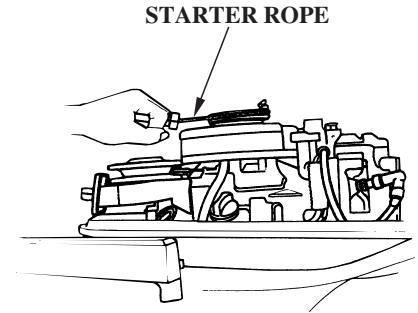

4. Pull the emergency starter rope slowly until resistance is felt, then pull briskly.

Keep away from moving parts while pulling the rope.

If necessary, rewind the rope and pull again. If the engine does not start after several attempts, refer to *TAKING CARE OF UNEXPECTED PROBLEMS*, p. 60 .

5. If the choke control was used to start the engine, return the control to the normal operating position as the engine warms up.

During the warm-up period, check the oil pressure indicator (p. 16), and cooling system indicator (p. 16).

6. Install the engine cover (p. 14), and lock it in place by locking the engine cover lock lever.

### **WARNING**

Exposed moving parts can cause injury.

- Do not operate the outboard motor without the engine cover.
- Use extreme care when installing the engine cover.

7. If it was necessary to remove the emergency stop switch lanyard from your wrist to perform the emergency starting procedure, be sure the lanyard is attached to your wrist before operating the outboard motor.
8. Have your closest authorized Honda marine dealer check your system and correct the problem, so you can use the recoil starter.

# OPERATION

## STOPPING THE ENGINE

### Emergency Engine Stopping

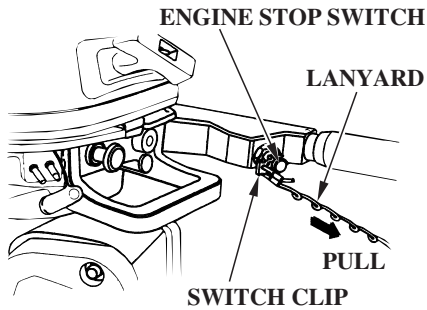

To stop the engine in an emergency, pull the clip out of the engine stop switch by pulling the lanyard.

We suggest that you stop the engine this way occasionally to verify that the engine or emergency stop switch is operating properly.

### Normal Engine Stopping

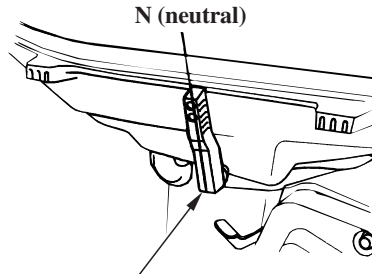
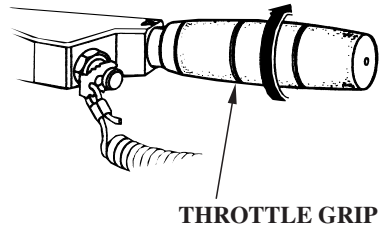

1. Move the throttle grip to the slowest speed and gearshift lever to the N (neutral) position.

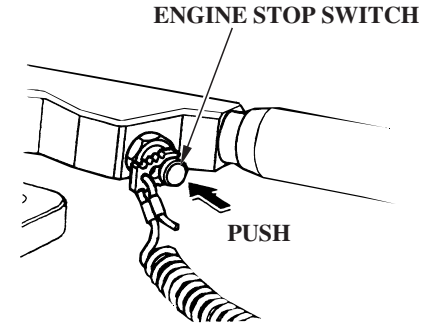

2. Press the engine stop switch until the engine stops.
3. When the boat is not in use, remove and store the emergency stop switch clip and lanyard.



**GEARSHIFTING AND THROTTLE OPERATION**

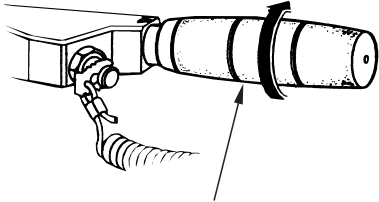

**THROTTLE GRIP**

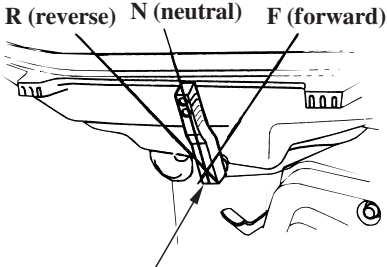

**GEARSHIFT LEVER**

To shift gears, turn the throttle grip to the SLOW position, then move the gearshift lever to select F (forward), N (neutral) or R (reverse) gears.

The engine can be started with the gearshift lever in the N (neutral) position only.

The throttle grip can be turned to the FAST position only when the gearshift lever is in the F (forward) position.

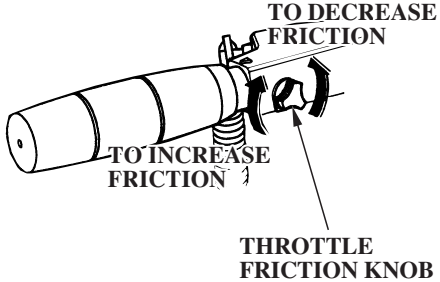

**THROTTLE FRICTION KNOB**

Use the throttle friction knob to help hold a constant throttle setting while cruising.

Turn the knob clockwise to increase throttle grip friction for holding a constant speed.

Turn the knob counterclockwise to decrease friction for easy grip rotation.

# OPERATION

---

## STEERING

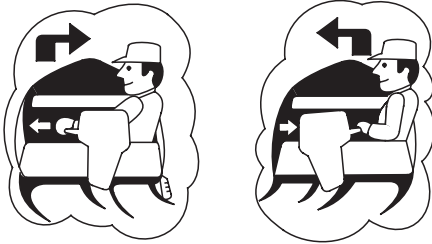

Steer by moving the tiller handle opposite the direction you want the boat to turn.

### STEERING FRICTION BOLT

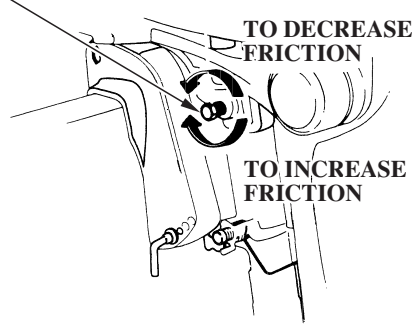

Use the steering friction bolt to help hold a steady course while cruising.

Turn the bolt clockwise to increase steering friction for holding a steady course.

Turn the bolt counterclockwise to decrease friction for easy turning.

**CRUISING**

**Engine Speed**

For best fuel economy, limit the throttle opening to 80%. Use the throttle friction control (p. 31 ) to help you hold a steady speed.

For rough water conditions or large waves, slow down to prevent the propeller from rising out of the water.

**Transom Angle**

Install the outboard motor at the best transom angle for stable cruising and maximum power.

Transom angle too large: Incorrect causes boat to “squat”.

Transom angle too small: Incorrect causes boat to “plow”.

It is necessary to adjust the transom angle of the outboard motor to compensate for changes in boat load, weight distribution, water conditions, or propeller selection.

Under normal conditions, the boat will perform best when the antiventilation plate is level with the water.

When cruising into a high wind, adjust the outboard motor down slightly to level the boat and improve stability. With a tail wind, adjust the outboard motor up slightly.

**NOTICE**

*Excessive transom angle during operation can cause propeller ventilation, overheating, and water pump damage.*

**Transom Angle (Cruising)**

**MOTOR ADJUSTED TOO LOW**

**MOTOR ADJUSTED TOO HIGH**

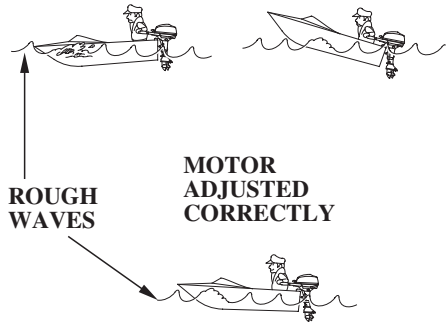

**CORRECT GIVES MAXIMUM PERFORMANCE**

## OPERATION

---

### SHALLOW WATER OPERATION

When operating in shallow water, tilt the outboard motor, using the tilt lever, so the propeller and gear case won't hit the bottom.

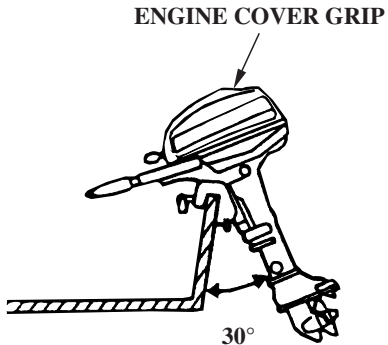

To tilt the outboard motor, raise the outboard motor to the 30° position by pulling on the engine cover grip.

#### NOTICE

*Do not use the tiller handle as a lever to raise the outboard motor. Applying excessive force to the tiller handle can damage it.*

While the outboard motor is tilted, proceed at a low speed, and do not operate the outboard motor in reverse. The outboard motor will rise suddenly if operated in reverse.

Monitor water flow from the cooling system indicator (p. 16 ) to be sure the outboard motor is not tilted so high the water intake is out of the water.

#### NOTICE

*An excessive tilt angle during operation can cause propeller ventilation, overheating, and water pump damage.*

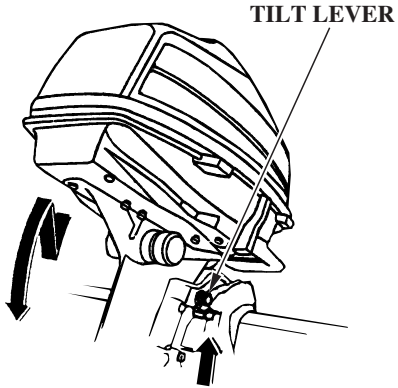

To return the outboard motor to the normal operating position, raise the outboard slightly by pulling on the engine cover grip, then pull the TILT lever to release the outboard, then slowly lower the outboard motor.

**MOORING, BEACHING,  
LAUNCHING**

**ENGINE COVER GRIP**

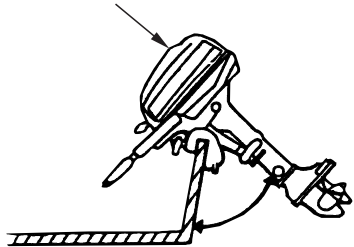

45°, 70° (when mooring)

To raise the outboard motor out of the water while the boat is moored, or for maximum clearance when beaching or launching, tilt the outboard motor to the 45° or 70° position.

Stop the engine before tilting the outboard motor. The 45° or 70° position is not an operating position.

Raise and lower the outboard motor as described on p. 34.

# SERVICING YOUR OUTBOARD MOTOR

## THE IMPORTANCE OF MAINTENANCE

Good maintenance is essential for safe, economical, and trouble-free operation. It will also help reduce air pollution.

### **WARNING**

Improperly maintaining this outboard motor, or failure to correct a problem before operation, can cause a malfunction in which you could be seriously hurt or killed.

Always follow the inspection and maintenance recommendations and schedules in this owner's manual.

To help you properly care for your outboard motor, the following pages include a maintenance schedule, routine inspection procedures, and simple maintenance procedures using basic hand tools. Other service tasks that are more difficult, or require special tools, are best handled by professionals and are normally performed by a Honda technician or other qualified mechanic.

The maintenance schedule applies to normal operating conditions. If you operate your outboard motor under unusual conditions, consult an authorized Honda marine dealer for recommendations applicable to your individual needs and use.

Remember that your authorized Honda marine dealer knows your outboard motor best and is fully equipped to maintain and repair it.

To ensure the best quality and reliability, use only new, genuine Honda parts or their equivalents for repair and replacement.

**Maintenance, replacement, or repair of the emission control devices and systems may be performed by any marine engine repair establishment or individual, using parts that are “certified” to EPA standards.**

## MAINTENANCE SAFETY

Some of the most important safety precautions follow. However, we cannot warn you of every conceivable hazard that can arise in performing maintenance. Only you can decide whether or not you should perform a given task.

### **WARNING**

Failure to properly follow maintenance instructions and precautions can cause you to be seriously hurt or killed.

Always follow the procedures and precautions in the owner's manual.

## Safety Precautions

- Make sure the engine is off before you begin any maintenance or repairs. This will eliminate several potential hazards:

- **Carbon monoxide poisoning from engine exhaust.**

Be sure there is adequate ventilation whenever you operate the engine.

- **Burns from hot parts.**

Let the engine and exhaust system cool before touching.

- **Injury from moving parts.**

Do not run the engine unless instructed to do so.

- Read the instructions before you begin, and make sure you have the tools and skills required.
- To reduce the possibility of fire or explosion, be careful when working around gasoline. Use only a nonflammable solvent, not gasoline, to clean parts. Keep cigarettes, sparks, and flames away from all fuel-related parts.
- Wear gloves when handling the propeller to protect your hands from sharp edges.

# SERVICING YOUR OUTBOARD MOTOR

## TOOL KIT AND EMERGENCY STARTER ROPE

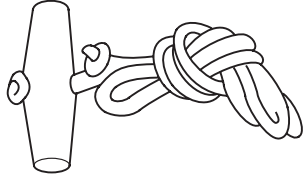

EMERGENCY STARTER ROPE

The following tools are supplied with the outboard motor for simple maintenance procedures and emergency repairs. An emergency starter rope is also supplied. Keep these items on the boat, so they will always be available if you need them.

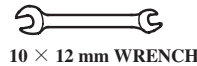

10 × 12 mm WRENCH



FLAT SCREWDRIVER



PLIERS

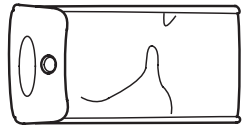

TOOL BAG



PHILIPS SCREWDRIVER

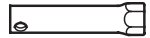

SPARK PLUG WRENCH



8 mm WRENCH



EMERGENCY ENGINE STOP SWITCH CLIP

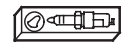

SPARE SPARK PLUG

COTTER PINS

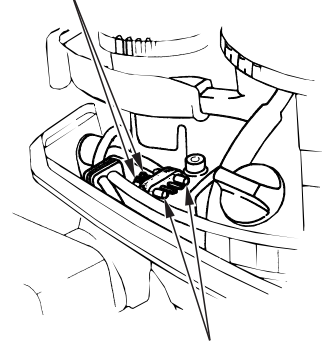

SHEAR PINS

FLUSH KIT

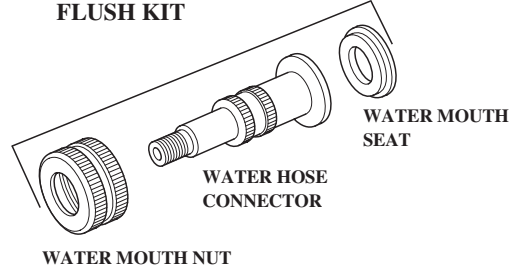

WATER HOSE CONNECTOR

WATER MOUTH NUT

WATER MOUTH SEAT



# SERVICING YOUR OUTBOARD MOTOR

## MAINTENANCE SCHEDULE

REGULAR SERVICE PERIOD (3) Perform at every indicated month or operating hour interval, whichever comes first.		Each use	After use	First month or 20 hrs.	Every 6 months or 100 hrs.	Every year or 200 hrs.
ITEM						
• Engine oil	Check level	<input type="radio"/>				
	Change			<input type="radio"/>	<input type="radio"/>	
Gear case oil	Change			<input type="radio"/>	<input type="radio"/>	
Starter rope	Check				<input type="radio"/>	
Carburetor linkage	Check-adjust			<input type="radio"/> (2)	<input type="radio"/> (2)	
• Valve clearance	Check-adjust			<input type="radio"/> (2)		<input type="radio"/> (2)
• Spark plug	Check-adjust				<input type="radio"/>	
	Replace					<input type="radio"/>
Propeller and Cotter pin	Check	<input type="radio"/>				
Anode	Check	<input type="radio"/>				
• Idling speed	Check-adjust			<input type="radio"/> (2)	<input type="radio"/> (2)	
Lubrication	Grease			<input type="radio"/> (1)	<input type="radio"/> (1)	

• Emission related items.

- (1) Lubricate more frequently when used in salt water.
- (2) These items should be serviced by an authorized Honda marine dealer, unless you have the proper tools and are mechanically proficient. Refer to the Honda shop manual for service procedures.
- (3) For professional/commercial use, log hours of operation to determine proper maintenance intervals.

# SERVICING YOUR OUTBOARD MOTOR

REGULAR SERVICE PERIOD (3) Perform at every indicated month or operating hour interval, whichever comes first.		Each use	After use	First month or 20 hrs.	Every 6 months or 100 hrs.	Every year or 200 hrs.
ITEM						
• Fuel tank and tank filter	Clean					○
	Thermostat					○ (2)
• Fuel filter	Check				○	
	Replace					○
• Fuel line	Check	○				
	Replace		Every 2 years (If necessary) (2)			
	Bolts and Nuts			○ (2)	○ (2)	
• Crankcase breather tube	Check					○ (2)
	Cooling water passages		○ (4)			

• Emission related items.

- (1) Lubricate more frequently when used in salt water.
- (2) These items should be serviced by an authorized Honda marine dealer, unless you have the proper tools and are mechanically proficient. Refer to the Honda shop manual for service procedures.
- (3) For professional/commercial use, log hours of operation to determine proper maintenance intervals.
- (4) When operating in salt water, turbid or muddy water, the engine should be flushed with clean water after each use.

# SERVICING YOUR OUTBOARD MOTOR

## ENGINE COVER REMOVAL AND INSTALLATION

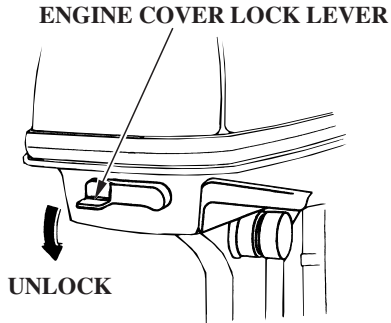

The engine cover lock lever fastens the engine cover to the outboard motor.

To remove the engine cover, turn the lock lever to the unlocked position, then lift the engine cover off the outboard motor.

To install the engine cover, place the cover on the outboard motor, then turn the lock lever to the locked position.

## Engine Oil Level Check

Check the engine oil level with the engine stopped and the outboard motor in the vertical position.

1. Unlock and remove the engine cover.
2. Remove the oil filler cap/dipstick and wipe it clean.

### OIL FILLER CAP/DIPSTICK

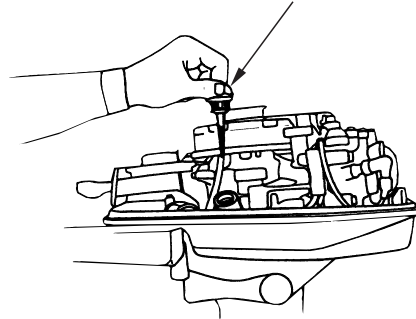

3. Insert the dipstick without screwing it in, then remove it and check the oil level shown on the dipstick.

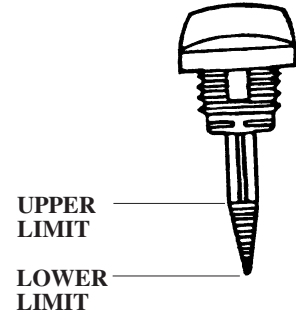

4. If the oil level is low, add oil to reach the upper limit mark shown on the dipstick. Use the oil recommended on p. 43.

### NOTICE

*Running the engine with a low oil level can cause engine damage.*

5. Install the oil filler cap/dipstick and tighten it securely.
6. Install and lock the engine cover.

# SERVICING YOUR OUTBOARD MOTOR

## Engine Oil Change

An engine oil evacuation device may be used to remove the engine oil.

Drain the used oil into a suitable container while the engine is warm. Warm oil drains quickly and completely.

1. Unlock and remove the engine cover (p. 41 ).

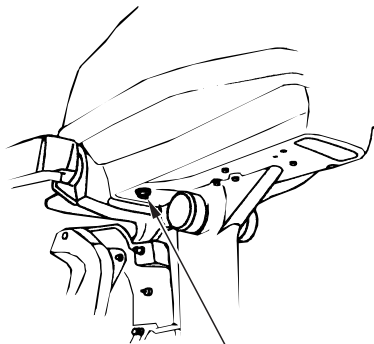

**DRAIN PLUG**

2. Remove the oil filler cap, and remove the engine oil drain plug and washer.
3. Allow the used oil to drain completely, then reinstall the engine oil drain plug and a new washer, and tighten it securely.

### NOTICE

*Improper disposal of engine oil can be harmful to the environment. If you change your own oil, please dispose of the used oil properly. Put it in a sealed container, and take it to a recycling center. Do not discard it in a trash bin or dump it on the ground.*

4. With the outboard motor in a vertical position, fill to the upper limit mark on the dipstick (p. 41 ) with the recommended oil.

Engine oil refill capacity:  
0.58 US qt (0.55 ℓ)

5. Install the oil filler cap and tighten it securely.
6. Install and lock the engine cover.

# SERVICING YOUR OUTBOARD MOTOR

## Engine Oil Recommendations

Oil is a major factor affecting performance and service life. Use 4-stroke automotive detergent oil.

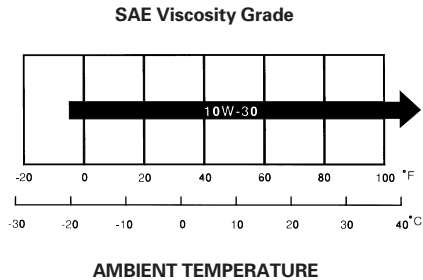

SAE 10W-30 is recommended for general use.

The SAE oil viscosity and service classification are in the API label on the oil container. Honda recommends that you use API SERVICE category SG, SH or SJ oil with the “starburst” certification mark displayed on the container.

# SERVICING YOUR OUTBOARD MOTOR

## Lubrication Points

Wipe the outside of the engine with a cloth dipped in oil.  
Apply marine waterproof grease to the following parts:

Lubrication interval:

20 operating hours or a month after the date of purchase  
or the initial use, then every 100 hours or 6 months.

### NOTICE

*To prevent corrosion, apply anticorrosion oil to pivot  
surfaces where grease cannot penetrate.*

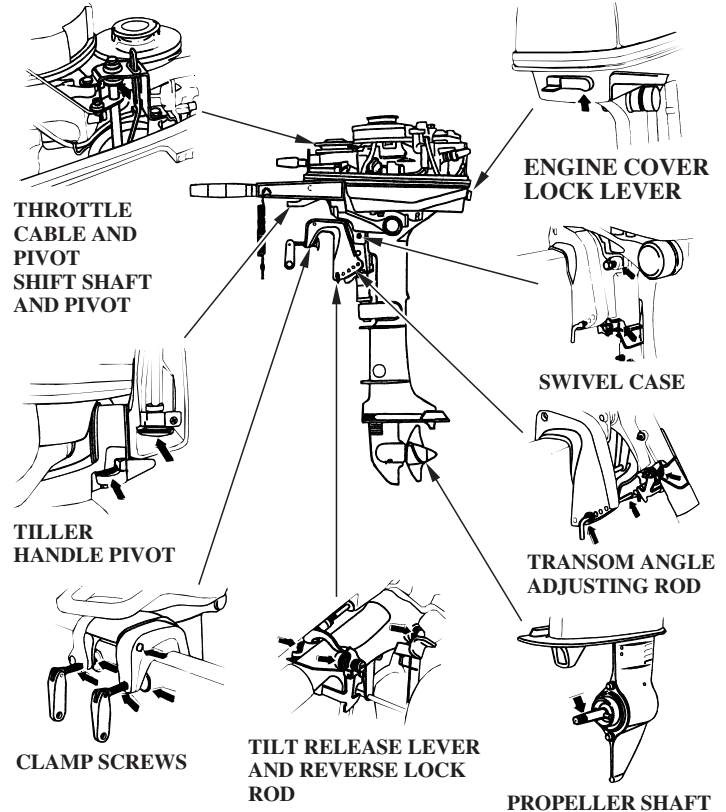

Apply Honda Marine Corrosion Inhibitor (or equivalent) to all areas under the engine cover.

## Spark Plug Service

RECOMMENDED SPARK PLUGS:  
BPR5ES (NGK)  
W16EPR-U (DENSO)

### NOTICE

*Incorrect spark plug can cause engine damage.*

1. Unlock and remove the engine cover (p. 41).
2. Disconnect the spark plug cap from the spark plug.
3. Remove the spark plug with a spark plug wrench and screwdriver supplied in the tool kit.

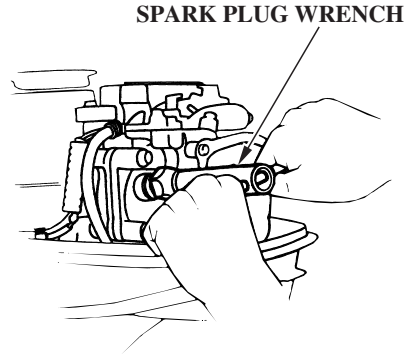

4. Inspect the spark plug. Replace them if the electrodes are worn, or if the insulators are cracked or chipped. Clean the spark plug with a wire brush if you are going to reuse them.

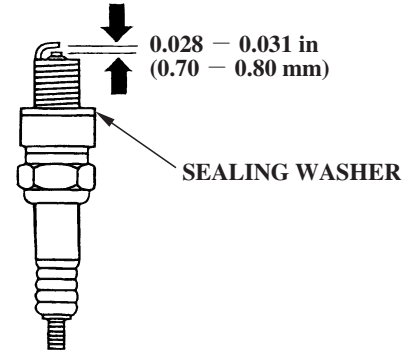

5. Measure the spark plug electrode gap with a suitable gauge. The gap should be 0.028 - 0.031 inches (0.70 - 0.80 mm). Correct the gap, if necessary, by bending the side electrode.

## SERVICING YOUR OUTBOARD MOTOR

---

6. Install the spark plug carefully, by hand, to avoid cross-threading.

7. After the spark plug seats, tighten with a spark plug wrench supplied in the tool kit to compress the sealing washer.

If reinstalling the used spark plug, tighten 1/8 - 1/4 turn after the spark plugs seat.

If reinstalling new spark plug, tighten 1/2 turn after the spark plugs seat.

**NOTICE**

*A loose spark plug can overheat and damage the engine.*

*Overtightening the spark plug can damage the threads in the cylinder head.*

8. Attach the spark plug cap.

9. Install and lock the engine cover.



# SERVICING YOUR OUTBOARD MOTOR

## REFUELING

### Portable Fuel Tank

FUEL TANK CAPACITY:  
3.2 US gal (12 ℓ)

Check the fuel gauge and refill the tank when necessary.

Remove the fuel tank from the boat for refueling.

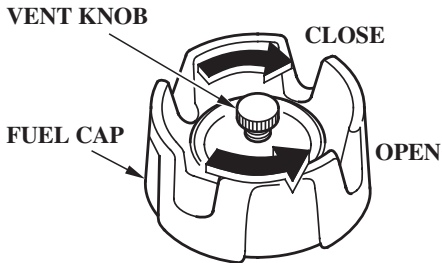

To refuel, turn the vent knob counterclockwise to the OPEN position, and unscrew the fuel tank cap.

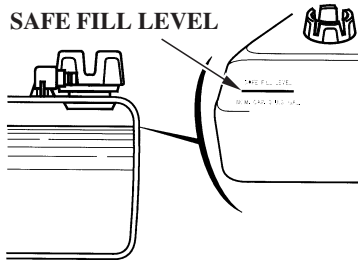
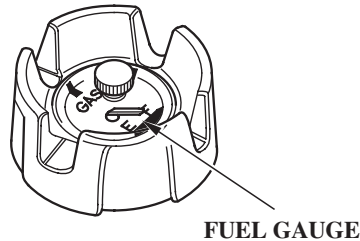

Refuel in a well-ventilated area. Fill the tank to the SAFE FILL LEVEL line.

After refueling, install the cap and tighten it securely. Turn the vent knob clockwise to the CLOSED position, and return the fuel tank to the boat.

## ⚠ WARNING

Gasoline is highly flammable and explosive.

You can be burned or seriously injured when handling fuel.

- Stop the engine and keep heat, sparks, and flame away.
- Handle fuel only outdoors.
- Wipe up spills immediately.

Never refill the fuel tank inside a building where gasoline fumes may reach flames or sparks. Keep gasoline away from appliance pilot lights, barbecues, electric appliances, power tools, etc.

Spilled fuel is not only a fire hazard, it causes environmental damage. Wipe up spills immediately.

# SERVICING YOUR OUTBOARD MOTOR

## FUEL RECOMMENDATIONS

**Use unleaded gasoline with a pump octane rating of 86 or higher.**

Your outboard motor is certified to operate on unleaded gasoline. Unleaded gasoline produces fewer engine and spark plug deposits and extends exhaust system life.

Never use stale or contaminated gasoline or an oil/gasoline mixture. Avoid getting dirt or water in the fuel tank.

Occasionally you may hear a light “spark knock” or “pinging” (metallic rapping noise) while operating under heavy loads. This is no cause for concern.

If spark knock or pinging occurs at a steady engine speed, under normal load, change brands of gasoline. If spark knock or pinging persists, see an authorized Honda marine dealer.

### NOTICE

*Running the engine with persistent spark knock or pinging can cause engine damage.*

Running the engine with persistent spark knock or pinging is misuse, and the *Distributor's Limited Warranty* does not cover parts damaged by misuse.

### Fuel Pump Filter Inspection and Replacement

The fuel pump filter is located under the engine cover, on the right side of the engine.

Water or sediment accumulated in the filter can cause loss of power or hard starting. To prevent engine malfunction, inspect the filter and replace when necessary.

### ⚠ WARNING

Gasoline is highly flammable and explosive.

You can be burned or seriously injured when handling fuel.

- Stop the engine and keep heat, sparks, and flame away.
- Handle fuel only outdoors.
- Wipe up spills immediately.

# SERVICING YOUR OUTBOARD MOTOR

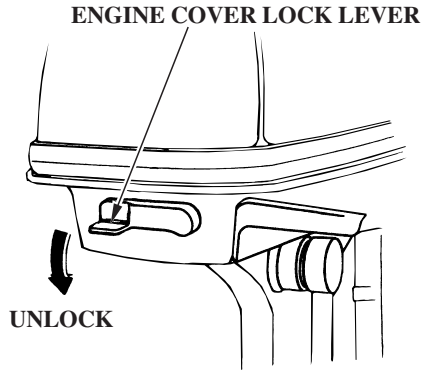

1. Unlock and remove the engine cover for access to the fuel pump filter.
2. Inspect the filter for water and/or sediment accumulation.

If the filter is OK, reinstall it. If water and/or sediment are present, replace the filter as described in the following steps. Always replace the filter at the scheduled replacement interval (p. 40).

3. Disconnect the fuel hose connector from the outboard motor, and place clamps on the fuel tubes on each side of the filter to prevent fuel leakage when the fuel tubes are disconnected.

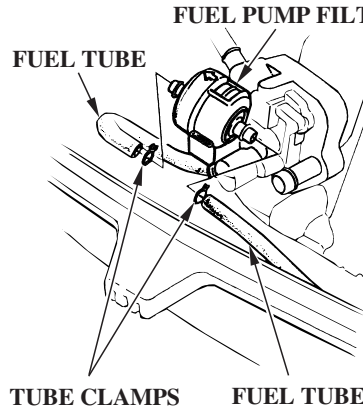

4. Remove the fuel tubes from the used filter, and discard the filter.

To ease tube removal, release the tube clamps by squeezing the clip ends together with pliers while pulling off the tubes.

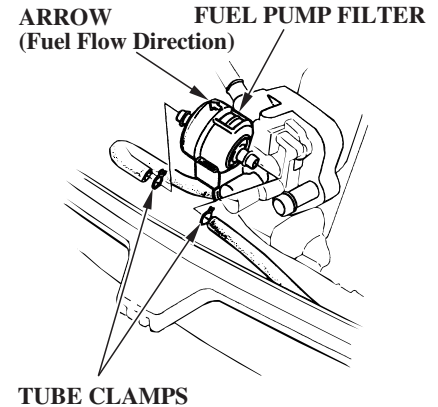

5. Install the new filter on the fuel tubes, with the fuel flow arrow pointing toward the fuel pump as shown. Fuel flow will be impeded if the filter is installed backward.
6. Connect the fuel tubes to the fuel filter securely with the tube clamps. Remove the fuel tube clamps used to close the fuel tubes.

# SERVICING YOUR OUTBOARD MOTOR

7. Securely connect the fuel hose connector to the outboard motor (refer to page 24).
8. Prime the engine using the priming bulb (p. 25). Check for fuel leaks. Repair any fuel leaks if necessary.
9. Install and lock the engine cover.

If loss of power or hard starting are found to be caused by excessive water or sediment accumulation in the fuel filter, inspect the fuel tank.

Clean the fuel tank and tank filter if necessary. It may be necessary to drain the fuel tank completely and refill with fresh gasoline.

## Portable Fuel Tank and Filter Cleaning

### *Fuel Tank*

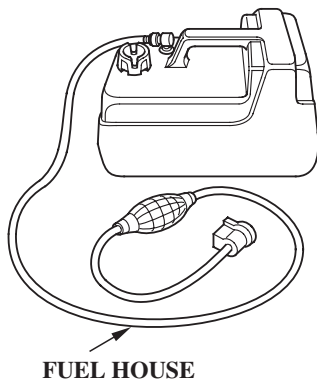

Empty the portable fuel tank into an approved gasoline container. Use a funnel to avoid spilling fuel. Rinse the fuel tank with nonflammable solvent to remove any accumulated sediment.

### *Fuel Tank Filter*

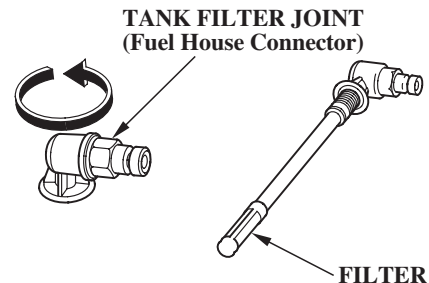

1. Unscrew the fuel hose connector by turning it counterclockwise, then remove the fuel hose connector and fuel tank filter from the tank.
2. Clean the filter in nonflammable solvent. Inspect the fuel tank filter and the connector O-ring. Replace them if damaged.
3. Reinstall the filter and hose connector in the fuel tank. Tighten the hose connector securely.

# SERVICING YOUR OUTBOARD MOTOR

## Recoil Starter Rope Inspection

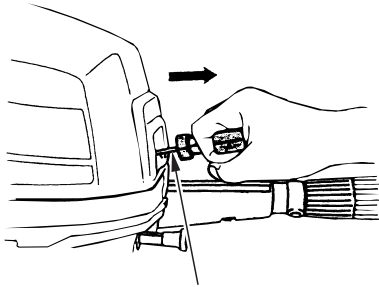

RECOIL STARTER ROPE

Inspect the recoil starter rope, and replace it if it becomes frayed.

Always keep the emergency starter rope on the boat in case the recoil starter rope fails.

## Anode Replacement

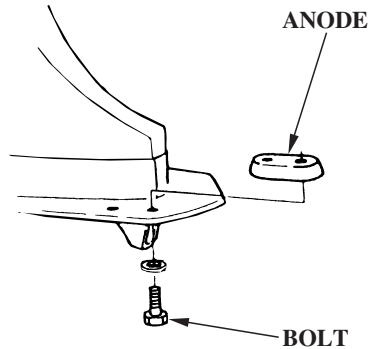

The anode is located on the antivibration plate. It is made of a sacrificial material that helps to protect the outboard motor from corrosion.

Replace the anode when it has been reduced to about half its original size, or if it is crumbling.

### NOTICE

*Painting or coating the anodes will defeat their purpose and will lead to rust and corrosion damage to the outboard motor. The anodes must be exposed to the water in order to protect the outboard motor.*

# SERVICING YOUR OUTBOARD MOTOR

## Propeller Replacement

Before replacing the propeller, remove the clip from the engine stop switch to prevent any possibility of the engine being started while you are working with the propeller.

The propeller blades may have sharp edges, so wear heavy gloves to protect your hands.

### Removal

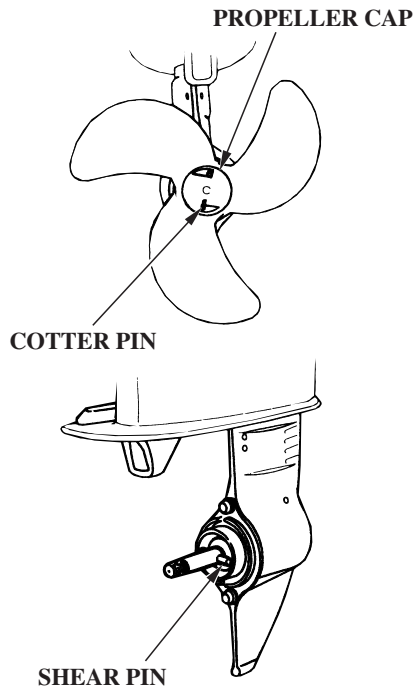

Remove the cotter pin and propeller cap, then remove the propeller and shear pin.

### Installation

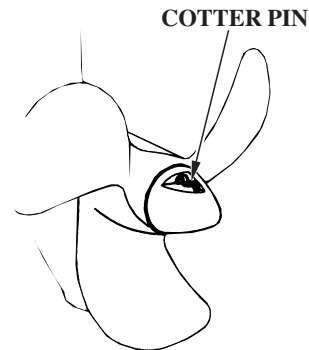

1. Install the propeller in the reverse order of removal.

#### NOTICE

*Use a genuine Honda stainless steel cotter pin and bend the pin ends as shown. A non-stainless steel cotter pin can deteriorate if used in salt water.*

## STORAGE PREPARATION

Proper storage preparation is essential for keeping your outboard motor troublefree and looking good. The following steps will help to keep rust and corrosion from impairing your outboard motor's function and appearance, and will make the engine easier to start when you use the outboard motor again.

### Cleaning and Flushing

Thoroughly clean and flush the outboard motor with fresh water after operation in dirty water or salt water.

#### *Cleaning*

Wash the outside of the outboard motor with clean, fresh water to remove mud, salt, seaweed, etc.

Disengage the emergency engine stop switch clip from the engine stop switch, and pull the recoil starter rope several times to expel any water

remaining in the water pump.

Touch up any damaged paint, and coat areas that may rust with Honda Corrosion Inhibitor, or equivalent. Lubricate controls with a silicone spray lubricant.

#### *Flushing With the Honda Garden Hose Connector (Optional equipment)*

1. Remove the flush plug from the WASH plug hole and install the water hose connector.
2. Attach a hose from a fresh water faucet to the water hose connector of the flush kit.
3. Remove the propeller (P. 52).
4. Turn on the fresh water supply to the hose.
5. Start the engine and run in N (neutral) for 10 minutes.

#### WATER HOSE CONNECTOR (Optional equipment)

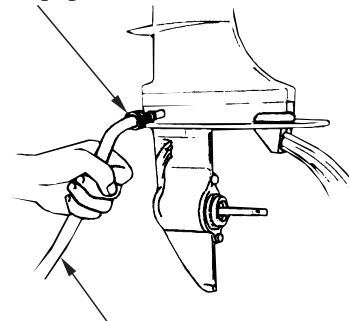

WATER HOSE

6. After flushing, stop the engine, remove the hose connector, and reinstall the flush plug and the propeller (P. 52).

## STORAGE

---

### *Flushing Without the Honda Garden Hose Connector*

It is necessary to run the engine during the flushing procedure. For safety, remove the propeller from the outboard motor (p. 52).

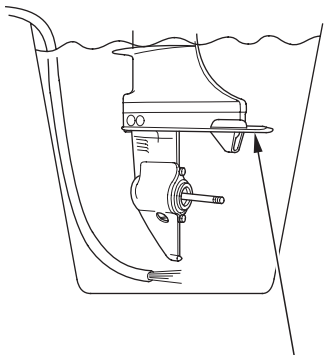

**ANTIVENTILATION PLATE**

1. Place a container under the outboard motor, and fill it with clean, fresh water. The water level must be at least 2 inches above the antiventilation plate.

#### **NOTICE**

*Running the engine without good water circulation can cause overheating and water pump damage.*

Damage caused by running the outboard motor without sufficient cooling water is not covered by the *Distributor's Limited Warranty*.

2. Start the engine and run in the N (neutral) position at low speed for at least 10 minutes.
3. After flushing, stop the engine, remove the water container, and reinstall the propeller (p. 52).



## Fuel

Gasoline will oxidize and deteriorate in storage. Old gasoline will cause hard starting, and it leaves gum deposits that clog the fuel system. If the gasoline in your fuel tank and carburetor deteriorates during storage, you may need to have the carburetor and other fuel system components serviced or replaced.

The length of time that gasoline can be left in your fuel tank and carburetor without causing functional problems will vary with such factors as gasoline blend, your storage temperatures, and whether the fuel tank is partially or completely filled. The air in a partially filled fuel tank promotes fuel deterioration. Very warm storage temperatures accelerate fuel deterioration. Fuel deterioration problems may occur within a few months, or even less if the gasoline was not fresh when you filled the fuel tank.

### *Adding a Fuel Stabilizer*

When adding a fuel stabilizer, fill the fuel tank with fresh gasoline. If only partially filled, air in the tank will promote fuel deterioration during storage. If you keep an additional container of gasoline for refueling, be sure that it contains only fresh gasoline.

1. Add fuel stabilizer following the manufacturer's instructions.
2. After adding a fuel stabilizer, run the engine in water for 10 minutes to be sure that the treated gasoline has replaced the untreated gasoline in the carburetor.
3. Turn the engine OFF.

The *Distributor's Limited Warranty* does not cover fuel system damage or engine performance problems resulting from neglected storage preparation.

### *Draining the Fuel System*

You can avoid fuel deterioration problems by draining the fuel tank and carburetors.

1. Disconnect the fuel hose from the outboard motor.

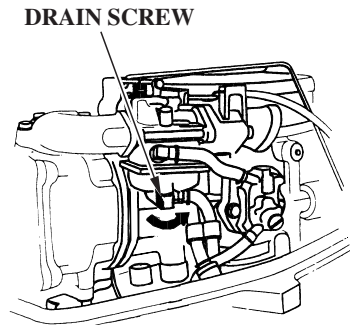

## STORAGE

---

2. With the outboard motor in a vertical position, place an approved gasoline container below the fuel drain outlet, and use a funnel to avoid spilling fuel. Loosen the drain screw to drain fuel from the carburetor.

### **WARNING**

Gasoline is highly flammable and explosive.

You can be burned or seriously injured when handling fuel.

- Stop the engine and keep heat, sparks, and flame away.
- Handle fuel only outdoors.
- Wipe up spills immediately.

3. After the fuel has drained from the carburetor, tighten the drain screw securely.
4. Drain the portable fuel tank into an approved gasoline container, or if you need to store fuel in the fuel tank, you can extend fuel storage life by filling the fuel tank with fresh gasoline and adding a fuel stabilizer that is formulated for that purpose. Firmly close the fuel cap vent knob.

## Engine Oil

1. Change the engine oil (p. 42).
2. Remove the spark plug (p. 45), and remove the clip from the engine stop switch.
3. Pour a tablespoon (5 — 10 cm<sup>3</sup>) of clean engine oil into the cylinder.
4. Pull the starter rope several times to distribute the oil in the cylinder.
5. Reinstall the spark plug (p. 46).

## STORAGE PRECAUTIONS

Select a well-ventilated storage area. If possible, avoid storage areas with high humidity.

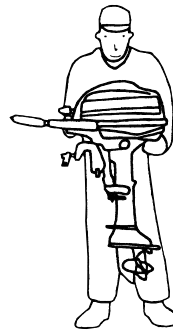
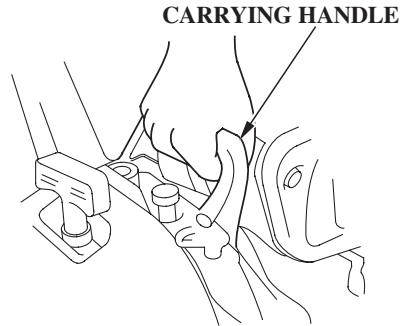

To carry the outboard motor, hold it by the carrying handle, or hold by the carrying handle and the lug beneath the engine cover lock lever, as shown.

### NOTICE

*Lifting the outboard motor by the engine cover, or using the installed outboard motor as a handle or lever to move the boat, can damage the outboard motor.*

If your portable fuel tank contains gasoline, store it away from any appliance that operates with a flame, such as a furnace, water heater, or clothes dryer. Also avoid any area with a spark-producing electric motor, or where power tools are operated.

## STORAGE

---

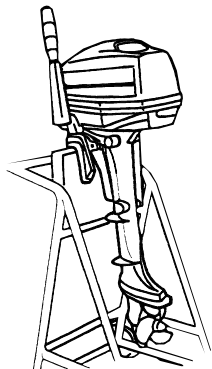

Store the outboard motor either vertically or horizontally with the tiller handle side up.

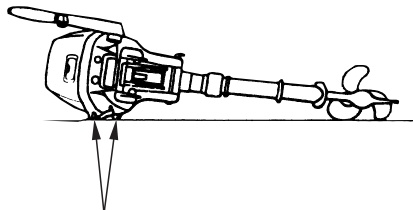

CASE PROTECTORS

If storing horizontally, be sure to fold the tiller handle, and the outboard motor rests on its case protectors. Be sure all water has drained from the outboard motor before placing it on its side, so no residual water can enter the engine exhaust port.

### NOTICE

*Any other horizontal storage position may cause damage or oil leakage.*

Cover the outboard motor to keep out dust. Do not use sheet plastic as a dust cover. A nonporous cover will trap moisture, promoting rust and corrosion.

### REMOVAL FROM STORAGE

Check your outboard motor as described in the *BEFORE OPERATION* chapter of this manual.

If the cylinder was coated with oil during storage preparation, the engine may smoke briefly at startup. This is normal.

# TRANSPORTING

## WITH OUTBOARD MOTOR INSTALLED ON BOAT

When trailering a boat with the outboard motor attached, leave the engine in the normal running position, if possible, and tighten the steering friction bolt securely (p. 32).

If there is insufficient road clearance in the normal running position, then tilt the outboard motor and use a motor support bar, or remove the outboard motor from the boat. Refer to the manufacturer's instructions for using a motor support bar.

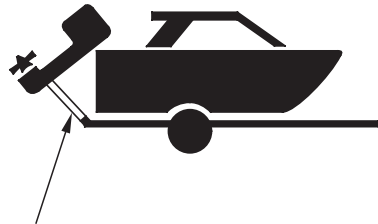

**MOTOR SUPPORT BAR**  
(commercially available)

## WITH OUTBOARD MOTOR REMOVED FROM BOAT

Secure the outboard motor in either the vertical or horizontal position shown on p. 58.

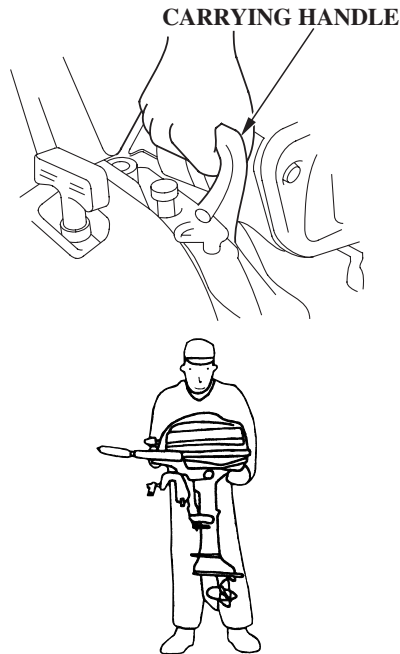

To carry, hold the outboard motor by the carrying handle, or hold by the carrying handle and the lug beneath engine cover lock lever, as shown.

### NOTICE

*Lifting the outboard motor by the engine cover, or using the installed outboard motor as a handle or lever to move the boat, can damage the outboard motor.*

## TAKING CARE OF UNEXPECTED PROBLEMS

ENGINE WILL NOT START	Possible Cause	Correction
1. Check emergency stop switch clip.	Clip not inserted in stop switch.	Insert clip in stop switch.
2. Check control positions.	Gearshift lever not in neutral position.	Shift to neutral (p. 13 ).
	Choke OPEN.	Pull choke knob to CLOSED position, unless engine is warm (p. 12 ).
	Throttle grip not in START position.	Turn throttle grip to START position (p. 26 ).

## TAKING CARE OF UNEXPECTED PROBLEMS

ENGINE WILL NOT START (continued)	Possible Cause	Correction
3. Check fuel.	Out of fuel.	Refuel (p. 47).
	Fuel vent closed (portable fuel tank).	Open fuel tank vent (p. 17).
	Fuel hose not primed.	Squeeze priming bulb (p. 25).
	Fuel pump filter or fuel tank filter clogged.	Replace fuel filters (p. 48).
	Bad fuel; boat stored without treating or draining gasoline, or refueled with bad gasoline.	Drain fuel tank and carburetor (p. 55). Refill with fresh gasoline (p. 47).
4. Remove and inspect spark plugs.	Spark plug faulty, fouled or improperly gapped.	Clean, gap or replace spark plug (p. 45).
	Spark plug wet with fuel (flooded engine).	Dry and reinstall spark plug. Start engine with choke and throttle open.
5. Take outboard motor to an authorized Honda marine dealer, or refer to the shop manual.	Carburetor malfunction, fuel pump failure, ignition malfunction, stuck valves, etc.	Replace or repair faulty components as necessary.

## TAKING CARE OF UNEXPECTED PROBLEMS

---

HARD STARTING OR STALLS AFTER STARTING	Possible Cause	Correction
1. Check control positions.	Choke OPEN.	Pull choke knob to CLOSED position, unless engine is warm (p. 12).
	Throttle grip not in START position.	Turn throttle grip to START (p. 26).
2. Check fuel.	Fuel vent closed (portable fuel tank).	Open fuel tank vent (p. 17).
	Fuel hose not primed. Fuel pump filter or fuel tank filter clogged.	Squeeze priming bulb (p. 25 ). Replace fuel filters (p. 48 ).
	Bad fuel; boat stored without treating or draining gasoline, or refueled with bad fuel.	Drain fuel tank and carburetor (p. 55 ). Refill with fresh gasoline (p. 47 ).



## TAKING CARE OF UNEXPECTED PROBLEMS

HARD STARTING OR STALLS AFTER STARTING (continued)	Possible Cause	Correction
3. Remove and inspect spark plug.	Spark plug faulty, fouled or improperly gapped.	Clean, gap or replace spark plug (p. 45).
4. Take outboard motor to an authorized Honda marine dealer, or refer to the shop manual.	Carburetor malfunction, fuel pump failure, ignition malfunction, etc.	Replace or repair faulty components as necessary.

ENGINE OVERHEATS	Possible Cause	Correction
1. Check water intake screens.	Water intake screens clogged.	Clean water intake screens.
2. Take outboard motor to an authorized Honda marine dealer, or refer to the shop manual.	Faulty thermostat or water pump.	Replace or repair faulty components as necessary.

## TAKING CARE OF UNEXPECTED PROBLEMS

---

ENGINE WILL NOT DRIVE THE PROPELLER	Possible Cause	Correction
1. Check shear pin.	Broken shear pin.	Replace shear pin (p. 52).
2. Take outboard motor to an authorized Honda marine dealer, or refer to the shop manual.	Damaged gearshift mechanism.	Replace or repair faulty components as necessary.

## TAKING CARE OF UNEXPECTED PROBLEMS

### OIL PRESSURE INDICATOR LIGHT GOES OFF AND ENGINE SPEED IS LIMITED

#### OIL PRESSURE INDICATOR LIGHT

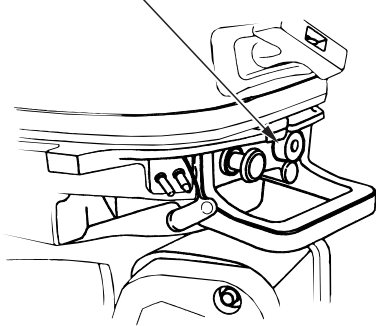

If oil pressure becomes low, the green indicator light will go off. If you are at cruising speed, engine speed will decrease gradually.

Low oil pressure may be the result of a low engine oil level, or there may be a problem with the engine lubrication system.

If the throttle is closed suddenly after full throttle operation, engine speed may drop below the specified idle rpm, and that could activate the engine protection system momentarily.

If low oil pressure activates the engine protection system, stop the engine, check the engine oil level (p. 41), and add oil if needed.

With the engine oil at the recommended level, restart the engine. If the lubrication system is OK, the green indicator light should come on within 30 seconds, and the engine will respond normally to throttle grip operation.

If the engine protection system remains activated after 30 seconds, return to the nearest boat landing, and have the outboard motor inspected by an authorized Honda marine dealer.

## TAKING CARE OF UNEXPECTED PROBLEMS

---

### SUBMERGED MOTOR

A submerged outboard motor must be serviced immediately after it is recovered from the water in order to minimize corrosion.

If there is a Honda marine dealer nearby, take the motor to the dealer immediately. If you are far from a dealer, proceed as follows:

1. Remove the engine cover, and rinse the outboard motor with fresh water to remove salt water, sand, mud, etc.
2. Drain the carburetor as described on p. 55 .

3. Change the engine oil as described on p. 42. If there was water in the engine crankcase, or if the used engine oil showed signs of water contamination, then a second engine oil change should be performed after running the engine for half an hour.

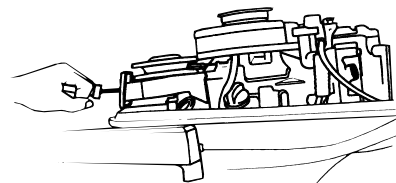

4. Remove the spark plug (p. 45 ), and remove the clip from the engine stop switch. Pull the recoil starter grip, rotate the flywheel a few revolutions to completely expel any water from the cylinder.

If the engine was running when it submerged, there may be mechanical damage, such as a bent connecting rod. If the engine binds when cranked, do not attempt to run the engine until it has been repaired.

## TAKING CARE OF UNEXPECTED PROBLEMS

### NOTICE

*When cranking the engine with an open ignition circuit (spark plug removed from the ignition circuit), remove the clip from the engine stop switch to prevent possible damage to the ignition system.*

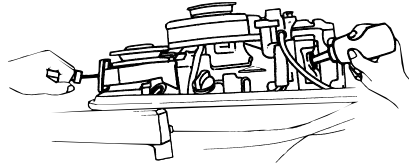

5. Pour a teaspoon of engine oil into the spark plug hole, then pull the recoil starter grip several times to lubricate the inside of the cylinder.
6. Reinstall the spark plug, and put the emergency stop switch clip into the switch.

7. Attempt to start the engine.

If the engine fails to start, remove the spark plug, clean and dry it, then reinstall the spark plug and attempt to start the engine again.

If the engine starts, and no mechanical damage is evident, continue to run the engine for a half hour or longer. Be sure the water level is at least two inches above the antiventilation plate to avoid overheating and water pump damage.

8. As soon as possible, take the outboard motor to an authorized Honda marine dealer for inspection and service.

# TECHNICAL AND CONSUMER INFORMATION

## TECHNICAL INFORMATION

### Serial Number Locations

Record the product identification number and engine serial number in the space provided on this page. You will need these numbers when ordering parts, and when making technical or warranty inquiries (p. 76 ).

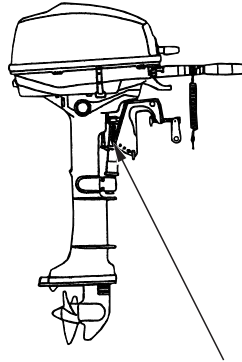

**PRODUCT IDENTIFICATION  
NUMBER**

The product identification number is stamped on the swivel case.

Product identification number:

---

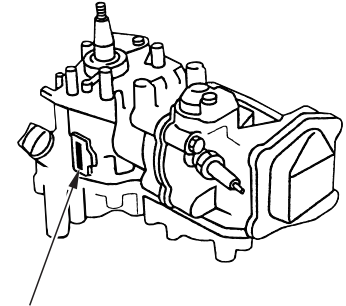

**ENGINE SERIAL NUMBER**

The engine serial number is stamped on the right front of the engine.

Engine serial number:

---

### Carburetor Modification for High Altitude Operation

At high altitude, the standard carburetor air-fuel mixture will be too rich. Performance will decrease, and fuel consumption will increase. A very rich mixture will also foul the spark plug and cause hard starting.

High altitude performance can be improved by specific modifications to the carburetor. If you always operate your outboard motor at altitudes above 5,000 feet (1,500 meters), have an authorized Honda marine dealer perform this carburetor modification.

Even with carburetor modification, engine horsepower will decrease about 3.5% for each 1,000-foot (300-meter) increase in altitude. The effect of altitude on horsepower will be greater than this if no carburetor modification is made.

#### NOTICE

*When the carburetor has been modified for high altitude operation, the air-fuel mixture will be too lean for low altitude use. Operation at altitudes below 5,000 feet (1,500 meters) with modified carburetor may cause the engine to overheat and result in serious engine damage. For use at low altitudes, have an authorized Honda marine dealer return the carburetor to original factory specifications.*

## TECHNICAL AND CONSUMER INFORMATION

---

### Oxygenated Fuels

Some conventional gasolines are being blended with alcohol or an ether compound. These gasolines are collectively referred to as oxygenated fuels. To meet clean air standards, some areas of the United States and Canada use oxygenated fuels to help reduce emissions.

If you use an oxygenated fuel, be sure it is unleaded and meets the minimum octane rating requirement.

Before using an oxygenated fuel, try to confirm the fuel's contents. Some states/provinces require this information to be posted on the pump.

The following are the EPA-approved percentages of oxygenates:

**ETHANOL:** ethyl or grain alcohol; 10% by volume.

You may use gasoline containing up to 10% ethanol by volume. Gasoline containing ethanol may be marketed under the name "Gasohol".

**MTBE:** Methyl Tertiary Butyl Ether; 15% by volume.

You may use gasoline containing up to 15% MTBE by volume.

**METHANOL:** methyl or wood alcohol; 5% by volume.

You may use gasoline containing up to 5% methanol by volume, as long as it also contains cosolvents and corrosion inhibitors to protect the fuel system. Gasoline containing more than 5% methanol by volume may cause starting and/or performance problems. It may also

damage metal, rubber, and plastic parts of your fuel system.

If you notice any undesirable operating symptoms, try another service station, or switch to another brand of gasoline.

Fuel system damage or performance problems resulting from the use of an oxygenated fuel containing more than the percentages of oxygenates mentioned above are not covered under warranty.



### **Emission Control System Information**

#### *Source of Emissions*

The combustion process produces carbon monoxide, oxides of nitrogen, and hydrocarbons. Control of hydrocarbons and oxides of nitrogen is very important because, under certain conditions, they react to form photochemical smog when subjected to sunlight. Carbon monoxide does not react in the same way, but it is toxic.

Honda utilizes lean carburetor settings and other systems to reduce the emissions of carbon monoxide, oxides of nitrogen, and hydrocarbons.

#### *The U.S. and California Clean Air Acts*

EPA and California regulations require all manufacturers to furnish written instructions describing the operation and maintenance of emission control systems.

The following instructions and procedures must be followed in order to keep the emissions from your Honda engine within the emission standards.

#### *Tampering and Altering*

Tampering with or altering the emission control system may increase emissions beyond the legal limit. Among those acts that constitute tampering are:

- Removal or alteration of any part of the intake, fuel, or exhaust systems.
- Alterations that would cause the engine to operate outside its design parameters.

## TECHNICAL AND CONSUMER INFORMATION

---

### *Problems That May Affect Emissions*

If you are aware of any of the following symptoms, have your engine inspected and repaired by your servicing dealer.

- Hard starting or stalling after starting.
- Rough idle.
- Misfiring or backfiring under load.
- Afterburning (backfiring).
- Black exhaust smoke or high fuel consumption.

### *Replacement Parts*

The emission control systems on your Honda engine were designed, built, and certified to conform with EPA and California emission regulations. We recommend the use of genuine Honda parts whenever you have maintenance done. These original-design replacement parts are manufactured to the same standards as the original parts, so you can be confident of their performance. The use of replacement parts that are not of the original design and quality may impair the effectiveness of your emission control system.

A manufacturer of an aftermarket part assumes the responsibility that the part will not adversely affect emission performance. The manufacturer or rebuilder of the part must certify that use of the part will not result in a failure of the engine to comply with emission regulations.

### *Maintenance*

Follow the maintenance schedule on p. 39. Remember that this schedule is based on the assumption that your machine will be used for its designed purpose. Sustained high-load operation, or use in unusual conditions, will require more frequent service.

# TECHNICAL AND CONSUMER INFORMATION

## Star Label

A Star label was applied to this outboard motor in accordance with the requirements of the California Air Resources Board.

## *The Star Label means Cleaner Marine Engine*

This engine has been certified as a:



## The Symbol for Cleaner Marine Engines:

**Cleaner Air and Water** - for healthier lifestyle and environment.

**Better Fuel Economy** - burns up to 30 - 40 percent less gas and oil than conventional carbureted two-stroke engines, saving money and resources.

**Longer Emission Warranty** - protects consumer for worry free operation.

## TECHNICAL AND CONSUMER INFORMATION

---



### **One Star Low Emission**

The one-star label identifies engines that meet the Air Resources Board's Personal Watercraft and Outboard marine engine 2001 exhaust emission standards. Engines meeting these standards have 75% lower emissions than conventional carbureted two-stroke engines. These engines are equivalent to the U.S.EPA's 2006 standards for marine engines.



### **Two Stars Very Low Emission**

The two-star label identifies engines that meet the Air Resources Board's Personal Watercraft and Outboard marine engine 2004 exhaust emission standards. Engines meeting these standards have 20% lower emissions than One Star-Low Emission engines.



### **Three Stars Ultra Low Emission**

The three-star label identifies engines that meet the Air Resources Board's Personal Watercraft and Outboard marine engine 2008 exhaust emission standards or the Sterndrive and inboard marine engine 2003-2008 exhaust emission standards. Engines meeting these standards have 65% lower emissions than One Star-Low Emission engines.



### **Four Stars Super Ultra Low Emission**

The four-star label identifies engines that meet the Air Resources Board's Sterndrive and Inboard marine engine 2009 exhaust emission standards. Personal Watercraft and Outboard marine engines may also comply with these standards. Engines meeting these standards have 90% lower emissions than One Star-Low Emission engines.

Cleaner Watercraft - Get the Facts  
1-800-END-SMOG  
[www.arb.ca.gov](http://www.arb.ca.gov)

# TECHNICAL AND CONSUMER INFORMATION

## Specifications

MODEL	BF5A	
Description Code	BADS	
Type	SA	LA
Overall length	20.7 in (525 mm)	
Overall width	13.8 in (350 mm)	
Overall height	39.6 in (1,005 mm)	44.7 in (1,135 mm)
Transom height	17.5 in (445 mm)	22.5 in (572 mm)
Weight	59.5 lbs (27.0 kg)	60.6 lbs (27.5 kg)
Rated power	3.7 kW (5.0 HP)	
Full throttle range	4,500 – 5,000 rpm	
Engine type	4 stroke OHV 1 cylinder, water-cooled	
Displacement	7.7 cu-in (127 cm <sup>3</sup> )	
Spark plug gap	0.028 – 0.031 in (0.70 – 0.80 mm)	
Starter system	Recoil starter	
Ignition system	Transistorized Ignition Control Module (ICM)	
Lubrication system	Trochoid pump pressure lubrication	
Specified oil	Engine: API standard (SG, SH, SJ) SAE 10W-30 Gear case: API standard (GL 4/5) SAE 90 outboard motor gear oil	
Oil capacity	Engine: 0.58 US qt (0.55 ℓ) Gear case: 0.1 US qt (0.1 ℓ)	
CARB star label	ULTRA LOW EMISSION	
Cooling system	Water cooling with thermostat	
Exhaust system	Underwater exhaust	

Spark plugs	BPR5ES (NGK) W16EPR-U (DENSO)
Fuel pump	Diaphragm type fuel pump
Fuel	Automotive unleaded gasoline (86 pump octane or higher)
Tank capacity	3.2 US gal (12 ℓ)
Gear change	Forward-Neutral-Reverse (dog type)
Steering angle	45° right and left
Transom angle	5 stages (5°, 9°, 13°, 17°, 21°)
Tilt angle	3 stages adjustment (30°, 45° and 70°)
Standard propeller (No. of blades- diameter × pitch)	7-25/32 × 7-31/64 in (3-200 × 190 mm)

## Tuneup

Spark plug gap	0.028 – 0.031 in (0.70 – 0.80 mm)	See page 45
Idle speed	1,300 ± 100 rpm	See shop manual
Valve clearance (cold)	Intake: 0.10 ± 0.04 mm Exhaust: 0.15 ± 0.04 mm	See shop manual
Other specifications	No other adjustment is needed	

Honda outboards are power rated in accordance with NMMA procedures and using the ICOMIA standard 28/23.

# TECHNICAL AND CONSUMER INFORMATION

---

## CONSUMER INFORMATION

### **Honda Publications**

These publications will give you additional information for maintaining and repairing your outboard motor. You may order them from your Honda marine dealer.

#### *Shop Manual*

This manual covers complete maintenance and overhaul procedures. It is intended to be used by a skilled technician.

#### *Parts Catalog*

This manual provides complete, illustrated parts lists.

## **Warranty Service Information**

Honda Marine dealership personnel are trained professionals. They should be able to answer any question you may have. If you encounter a problem that your dealer does not solve to your satisfaction, please discuss it with the dealership's management. The Service Manager or General Manager can help. Almost all problems are solved in this way.

If you are dissatisfied with the decision made by the dealership's management, contact the Honda Marine Customer Relations Office. You can write:

**American Honda Motor Co., Inc.**  
Marine Division  
Customer Relations Office  
4900 Marconi Drive  
Alpharetta, Georgia 30005-8847

Or telephone: (770) 497-6400

When you write or call, please give us this information:

- Model and serial numbers (p. 68 )
- Name of the dealer who sold the outboard motor to you
- Name and address of the dealer who services your outboard motor
- Date of purchase
- Your name, address, and telephone number
- A detailed description of the problem

# WIRING DIAGRAM

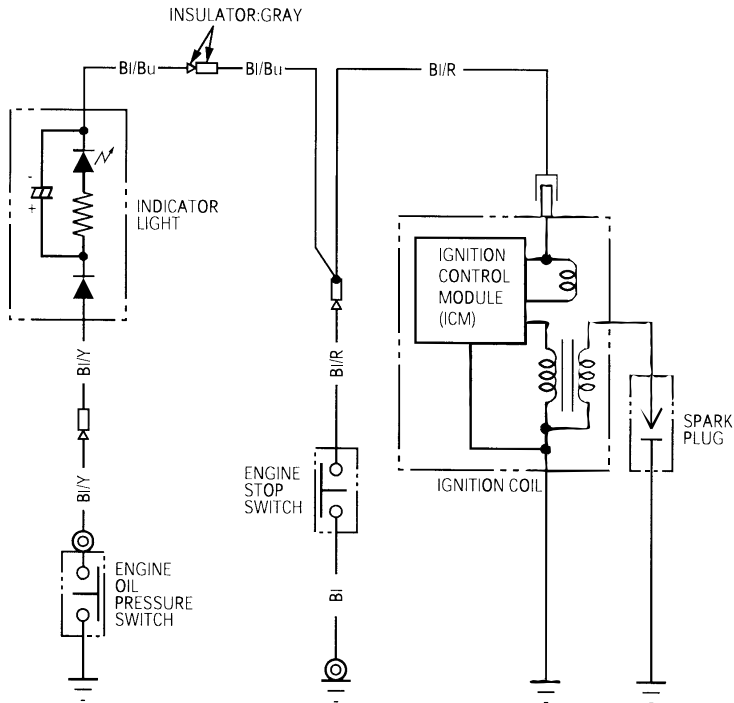

CHARGE RECEPTACLE KIT (OPTIONAL)

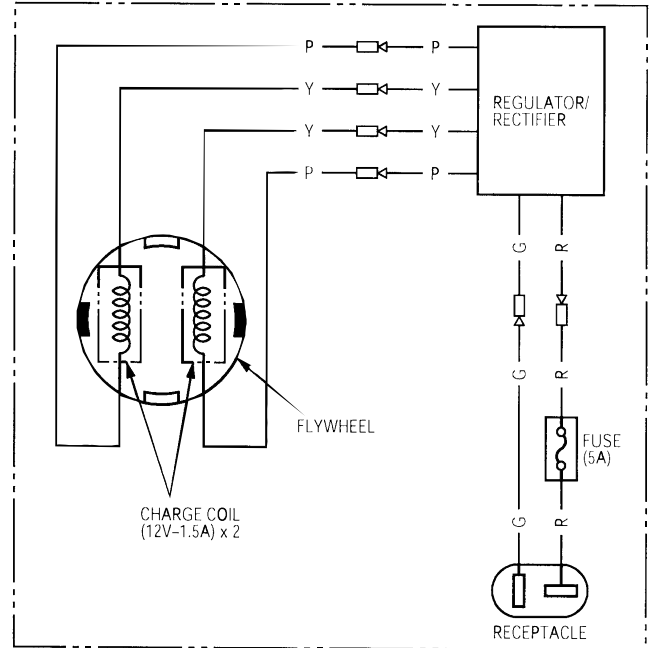

Bl	Black	Br	Brown
Y	Yellow	O	Orange
Bu	Blue	Lb	Light blue
G	Green	Lg	Light green
R	Red	P	Pink
W	White	Gr	Gray

# INDEX

Anode .....	17	EMERGENCY STARTING .....	27
Replacement .....	51	Emission Control System Information .....	71
ARE YOU READY TO GET UNDER WAY ? .....	21	Engine	
ATTACHMENT .....	20	Cover	
BEFORE OPERATION.....	21	Lock Lever .....	14
BREAK-IN PROCEDURE.....	23	REMOVAL AND INSTALLATION.....	41
Carburetor Modification for High Altitude Operation..	69	Oil	
Choke Knob.....	12	Change.....	42
COMPONENT AND CONTROL LOCATIONS .....	10	Level Check .....	41
CONSUMER INFORMATION .....	76	Recommendations .....	43
CONTROLS.....	12	ENGINE OVERHEATS .....	63
CONTROLS AND FEATURE IDENTIFICATION		Engine Stop Switch and Switch Clip.....	12
CODES.....	9	ENGINE WILL NOT DRIVE THE PROPELLER.....	64
CONTROLS AND FEATURES .....	9	ENGINE WILL NOT START .....	60
Cooling System Indicator.....	16	Fuel	
CRUISING .....	33	Cap Vent Knob.....	17
		Gauge.....	15
		HOSE CONNECTIONS .....	24
		PRIMING .....	25
		Priming Bulb .....	18
		Pump Filter Inspection and Replacement .....	48
		RECOMMENDATIONS .....	48



GEARSHIFTING AND THROTTLE OPERATION ...	31	Oil Pressure Indicator .....	16
Gearshift Lever .....	13	OIL PRESSURE INDICATOR LIGHT GOES OFF AND ENGINE SPEED IS LIMITED .....	65
HARD STARTING OR STALLS AFTER STARTING .....	62	OPERATION .....	23
Honda Publications .....	76	OTHER FEATURES .....	16
IMPORTANT SAFETY INFORMATION .....	6	OUTBOARD MOTOR SAFETY .....	6
INDEX .....	78	Overrev Limiter .....	16
INDICATORS .....	16	Oxygenated Fuels .....	70
INSTALLATION .....	19	Portable Fuel Tank .....	17, 24
INSTALLATION POSITION .....	19	Portable Fuel Tank and Filter Cleaning .....	50
INSTRUMENTS .....	15	POWER REQUIREMENTS .....	19
IS YOUR OUTBOARD MOTOR READY TO GO ? .....	21	Propeller Replacement .....	52
Lubrication Points .....	44	Recoil Starter Grip .....	14
MAINTENANCE SAFETY .....	37	Recoil Starter Rope Inspection .....	51
MAINTENANCE SCHEDULE .....	39	REFUELING .....	47
MOORING, BEACHING, LAUNCHING .....	35	REMOVAL FROM STORAGE .....	58

# INDEX

---

SAFE OPERATING PRECAUTIONS .....	23	TAKING CARE OF UNEXPECTED PROBLEMS.....	60
SAFETY LABEL LOCATIONS .....	8	TECHNICAL AND CONSUMER INFORMATION...	68
Serial Number Locations.....	68	TECHNICAL INFORMATION.....	68
SERVICING YOUR OUTBOARD MOTOR.....	36	THE IMPORTANCE OF MAINTENANCE .....	36
SHALLOW WATER OPERATION.....	34	Throttle Friction Knob .....	13
Spark Plug Service .....	45	Throttle Grip.....	13
Specifications .....	75	Tilt Lever .....	15
Star Label .....	73	TOOL KIT AND EMERGENCY STARTER ROPE ...	38
STARTING THE ENGINE .....	25	Transom Angle Adjusting Rod .....	14
STEERING.....	31	TRANSOM ANGLE ADJUSTMENT .....	20
Steering Friction Bolt.....	15	TRANSPORTING .....	59
STOPPING THE ENGINE.....	30	WITH OUTBOARD MOTOR INSTALLED	
Emergency Engine Stopping.....	30	ON BOAT .....	59
Normal Engine Stopping.....	30	WITH OUTBOARD MOTOR REMOVED	
STORAGE .....	53	FROM BOAT .....	59
STORAGE PRECAUTIONS.....	57	Warranty Service Information .....	76
STORAGE PREPARATION.....	53	WIRING DIAGRAM.....	77
Cleaning and Flushing .....	53		
Engine oil .....	57		
Fuel.....	55		
SUBMERGED MOTOR.....	66		

# HONDA

The power of dreams.™

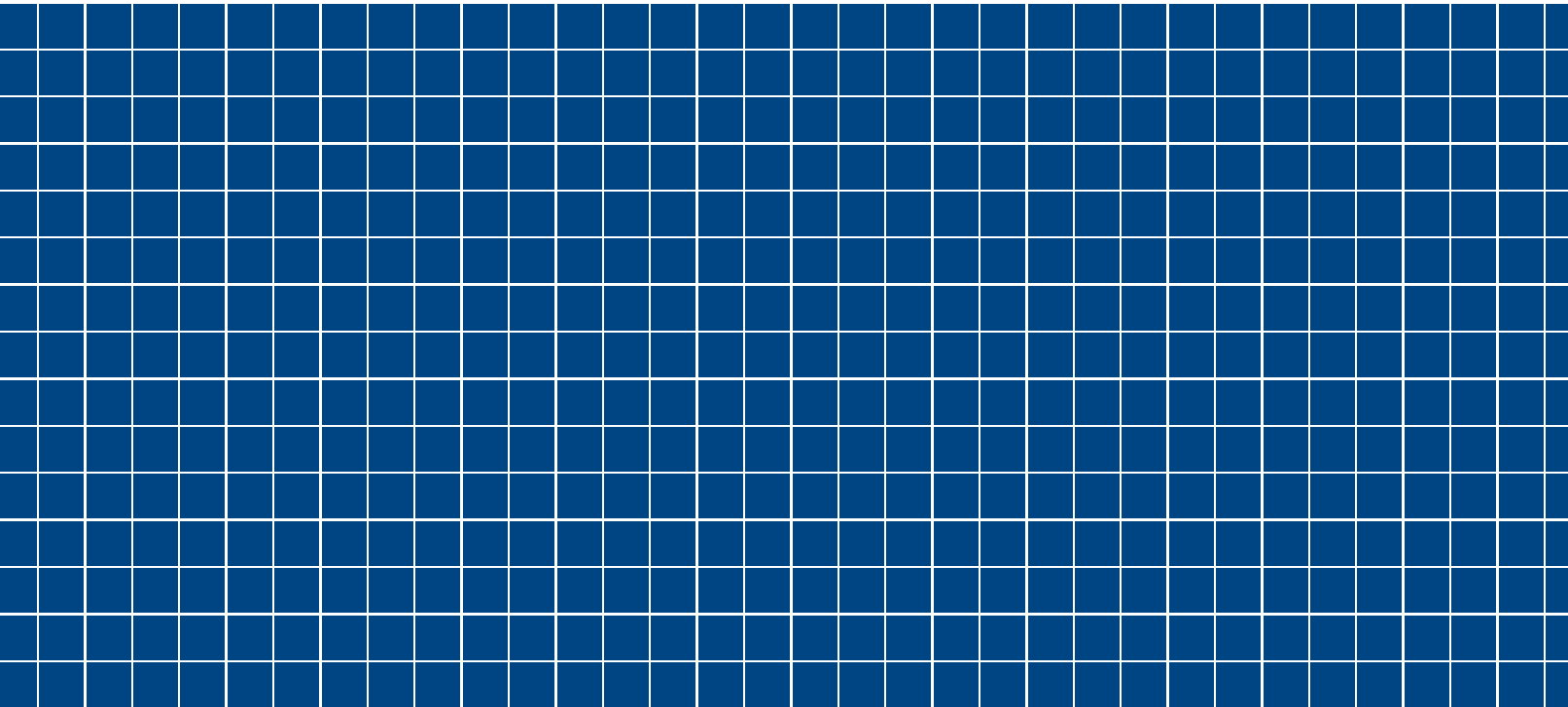

31ZV1635  
00X31-ZV1-6350



1000.2003.06

Printed in Japan