

HONDA

Power

Equipment

Owner's Manual

Outboard Motor

BF2A

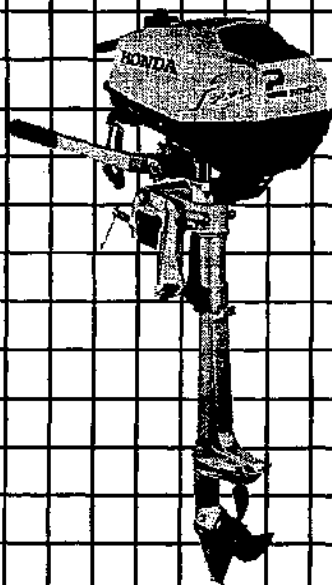



WARNING:



The engine exhaust from this product contains chemicals known to the State of California to cause cancer, birth defects or other reproductive harm.

Keep this owner's manual handy, so you can refer to it at any time. This owner's manual is considered a permanent part of the outboard motor and should remain with the outboard motor if resold.

The information and specifications included in this publication were in effect at the time of approval for printing. Honda Motor Co., Ltd. reserves the right, however, to discontinue or change specifications or design at any time without notice and without incurring any obligation whatever. No part of this publication may be reproduced without written permission.

INTRODUCTION

Congratulations on your selection of a Honda outboard motor. We are certain you will be pleased with your purchase of one of the finest outboard motors on the market.

We want to help you get the best results from your new outboard motor and to operate it safely. This manual contains the information on how to do that; please read it carefully.

As you read this manual, you will find information preceded by a **NOTICE** symbol. That information is intended to help you avoid damage to your outboard motor, other property, or the environment.

We suggest you read the warranty policy to fully understand its coverage and *your responsibilities of ownership*. The warranty policy is a separate document that should have been given to you by your dealer.

When your outboard motor needs scheduled maintenance, keep in mind that your Honda servicing dealer is specially trained in servicing Honda outboard motors. Your Honda servicing dealer is dedicated to your satisfaction and will be pleased to answer your questions and concerns.

Best Wishes,
Honda Motor Co., Ltd.

INTRODUCTION

A FEW WORDS ABOUT SAFETY

Your safety and the safety of others are very important. And using this outboard motor safely is an important responsibility.

To help you make informed decisions about safety, we have provided operating procedures and other information on labels and in this manual. This information alerts you to potential hazards that could hurt you or others.

Of course, it is not practical or possible to warn you about all the hazards associated with operating or maintaining a outboard motor. You must use your own good judgment.

You will find important safety information in a variety of forms, including:

- **Safety Labels** — on the outboard motor.
- **Safety Messages** — preceded by a safety alert symbol  and one of three signal words, DANGER, WARNING, or CAUTION.

These signal words mean:

DANGER

You **WILL** be **KILLED** or **SERIOUSLY HURT** if you don't follow instructions.

WARNING

You **CAN** be **KILLED** or **SERIOUSLY HURT** if you don't follow instructions.

CAUTION

You **CAN** be **HURT** if you don't follow instructions.

- **Safety Headings** — such as *IMPORTANT SAFETY INFORMATION*.
- **Safety Section** — such as *OUTBOARD MOTOR SAFETY*.
- **Instructions** — how to use this pump correctly and safely.

This entire book is filled with important safety information — please read it carefully.

CONTENTS

OUTBOARD MOTOR SAFETY	7
IMPORTANT SAFETY INFORMATION	7
Operator Responsibility	7
Refuel With Care	8
Carbon Monoxide Hazard	8
SAFETY LABEL LOCATIONS	9
CONTROLS & FEATURES	10
COMPONENT & CONTROL LOCATIONS	10
CONTROLS	12
Engine Stop Switch	12
Choke Knob	12
Throttle Lever	13
Fuel Valve Lever	13
Recoil Starter Grip	13
Steering Friction Bolt	14
Tilt Lever	14
Transom Angle Adjusting Bolt	15
Fuel Cap Vent Knob	15
FEATURES	16
Water Check Hole	16
Anode	16
INSTALLATION	17
INSTALLATION POSITION	17
INSTALLATION HEIGHT	17
OUTBOARD MOTOR ATTACHMENT	18
MOTOR ANGLE FOR CRUISING	18
MOTOR ANGLE ADJUSTMENT	19

CONTENTS

BEFORE OPERATION	20
ARE YOU READY TO GET UNDER WAY?	20
Knowledge	20
Safety Apparel	20
IS YOUR OUTBOARD MOTOR READY TO GO?	20
Safety Inspection	21
Maintenance Inspection	21
OPERATION	22
SAFE OPERATING PRECAUTIONS	22
BREAK-IN PROCEDURE	22
STARTING THE ENGINE	23
EMERGENCY STARTING	26
STOPPING THE ENGINE	27
Emergency Engine Stopping	27
Normal Engine Stopping	27
STEERING	29
CRUISING	30
REVERSING THE OUTBOARD MOTOR	31
TILTING THE OUTBOARD MOTOR	32
SERVICING YOUR HONDA OUTBOARD MOTOR	34
THE IMPORTANCE OF MAINTENANCE	34
MAINTENANCE SAFETY	35
Safety Precautions	35
TOOL KIT AND SPARE PARTS	36
MAINTENANCE SCHEDULE	37
REFUELING	38
FUEL RECOMMENDATIONS	39
COOLING SYSTEM CLEANING AND FLUSHING	40

CONTENTS

SERVICING YOUR HONDA OUTBOARD MOTOR (continued)	
ENGINE OIL LEVEL CHECK	41
ENGINE OIL CHANGE	42
ENGINE OIL RECOMMENDATIONS	43
GEAR OIL LEVEL CHECK	44
GEAR OIL CHANGE	45
LUBRICATION	46
SPARK PLUG SERVICE	47
RECOIL STARTER ROPE INSPECTION	49
ANODE REPLACEMENT	49
SHEAR PIN REPLACEMENT	50
HELPFUL TIPS & SUGGESTIONS	51
STORING YOUR OUTBOARD MOTOR	51
Storage Preparation	51
Storage Precautions	53
Removal From Storage	54
TRANSPORTING	54
TAKING CARE OF UNEXPECTED PROBLEMS	55
ENGINE WILL NOT START	55
SUBMERGED MOTOR	56
TECHNICAL & CONSUMER INFORMATION	58
TECHNICAL INFORMATION	58
Serial Number Locations	58
Carburetor Modification for High Altitude Operation	59
Oxygenated Fuels	60
Emission Control System Information	61
Specifications	62

CONTENTS

TECHNICAL & CONSUMER INFORMATION (continued)	
WIRING DIAGRAMS	65
CONSUMER INFORMATION	66
Honda Publications	66
Warranty Service Information	67
INDEX	68
QUICK REFERENCE INFORMATION	Inside back cover

OUTBOARD MOTOR SAFETY

IMPORTANT SAFETY INFORMATION

Honda BF2A outboard motor is designed for use with boats that have a suitable manufacturer's power recommendation, and other uses can result in injury to the operator or damage to the outboard motor and other property.

Most accidents can be prevented if you follow all instructions in this manual and on the outboard motor. The most common hazards are discussed below, along with the best way to protect yourself and others.

Operator Responsibility

- It is the operator's responsibility to provide the necessary safeguards to protect people and property. Know how to stop the engine quickly in case of emergency. Understand the use of all controls.
- Stop the engine immediately if anyone falls overboard, and do not run the engine while the boat is near anyone in the water.
- Always stop the engine if you must leave the controls for any reason.
- Attach the emergency stop switch lanyard securely to the operator.
- Always wear a PERSONAL FLOTATION DEVICE (PFD) while on the boat.
- Familiarize yourself with all laws and regulations relating to the boating and the use of outboard motors.
- Be sure that anyone who operates the outboard motor receives proper instruction.
- Be sure the outboard motor is properly mounted on the boat.
- Do not remove the engine cover while the engine is running.
- Do not attempt to modify the outboard motor.
- Do not remove any labels, covers, or safety devices; they are installed for your safety.

OUTBOARD MOTOR SAFETY

Refuel With Care

- Gasoline is extremely flammable, and gasoline vapor can explode. Refuel outdoors, in a well-ventilated area, with the engine stopped. Never smoke near gasoline, and keep other flames and sparks away.
- Refuel carefully to avoid spilling fuel. Avoid overfilling the fuel tank.
- After refueling, tighten the filler cap securely. If any fuel is spilled, make sure the area is dry before starting the engine.

Carbon Monoxide Hazard

Exhaust gas contains poisonous carbon monoxide. Avoid inhalation of exhaust gas. Never run the engine in a closed garage or confined area.

OUTBOARD MOTOR SAFETY

SAFETY LABEL LOCATIONS

The labels shown here contain important safety information. Please read them carefully. These labels are considered permanent parts of your outboard motor. If a label comes off or becomes hard to read, contact an authorized Honda servicing dealer for a replacement.

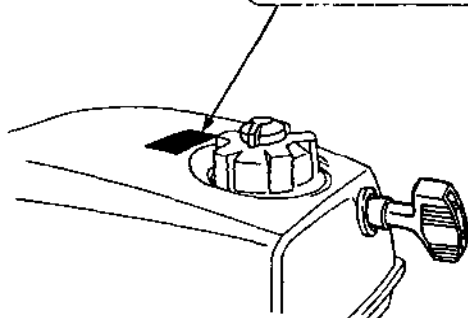
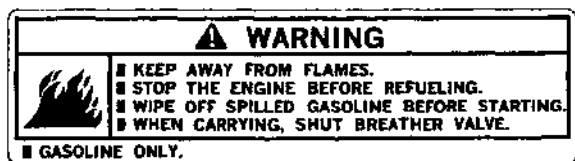
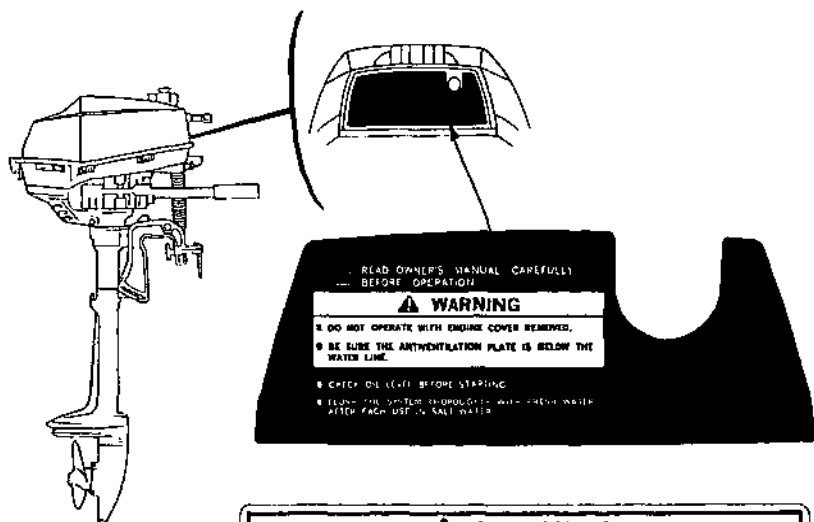

CONTROLS & FEATURES

COMPONENT & CONTROL LOCATIONS

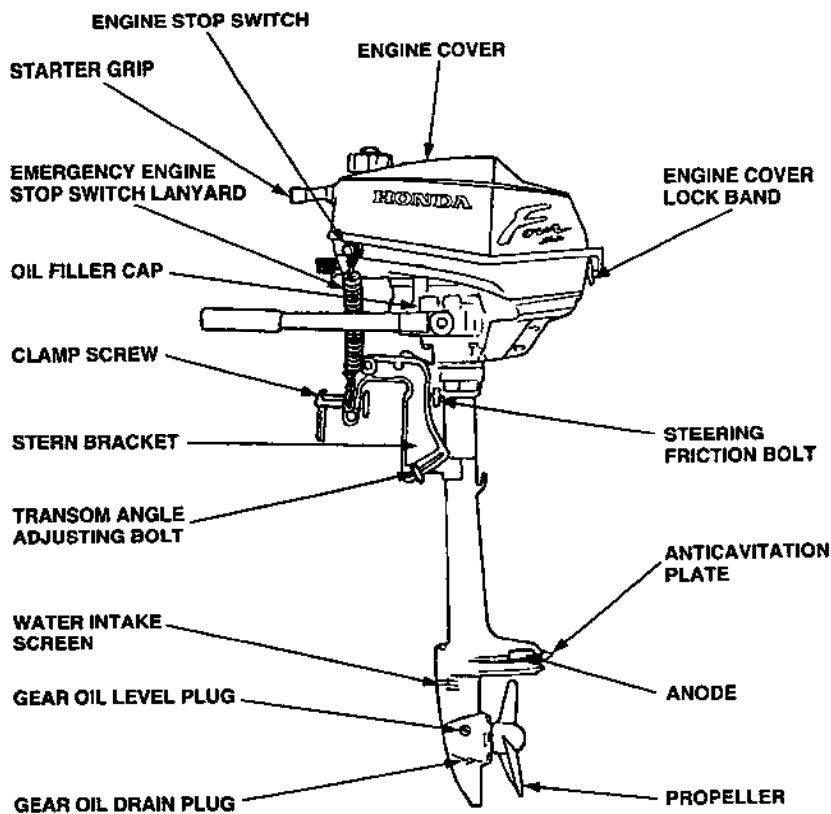

CONTROLS & FEATURES

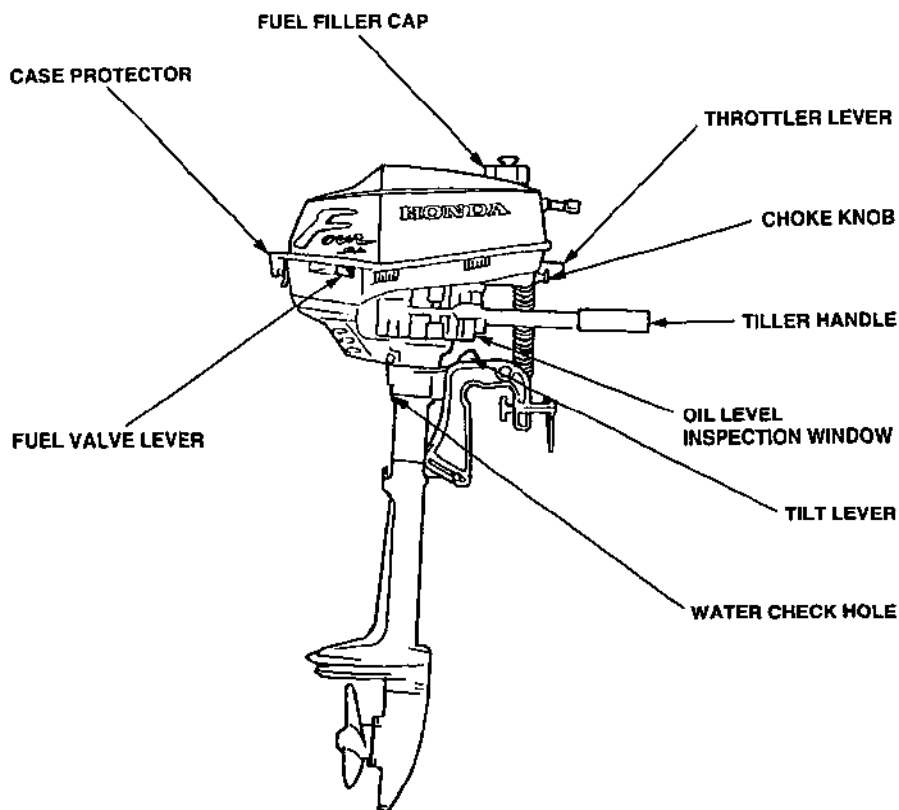

CONTROLS & FEATURES

CONTROLS

Engine Stop Switch

The engine stop switch has controls for normal engine stopping and emergency engine stopping.

In normal operation, press the engine stop button to stop the engine.

A clip and lanyard system stops the engine automatically if the operator falls away from the controls.

The switch clip must be inserted in the engine stop switch in order for the engine to start and run. The other end of the lanyard attaches to the operator's wrist. If the operator falls away from the controls, the lanyard pulls the clip out of the switch.

Always attach the lanyard to your wrist before operating the outboard motor.

A spare switch clip is supplied with the tool kit.

ENGINE STOP SWITCH

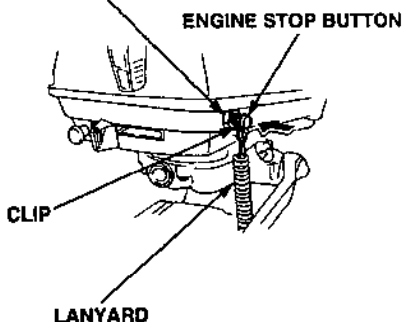

Choke Knob

The choke knob opens and closes the choke valve in the carburetor.

The CLOSED position enriches the fuel mixture for starting.

The OPEN position provides the correct fuel mixture for operation after starting, and for restarting a warm engine.

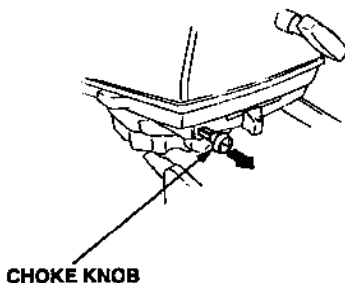

CONTROLS & FEATURES

Throttle Lever

The throttle lever controls engine speed.

Moving the throttle lever in the directions shown makes the engine run faster or slower.

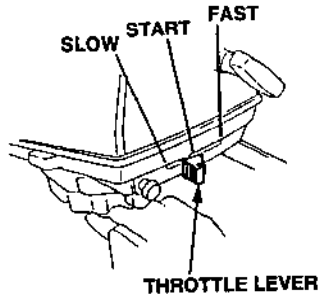

Fuel Valve Lever

The fuel valve opens and closes the connection between the fuel tank and the carburetor.

The fuel valve lever must be in the ON position for the engine to run.

When the engine is not in use, leave the fuel valve lever in the OFF position to prevent carburetor flooding and to reduce the possibility of fuel leakage.

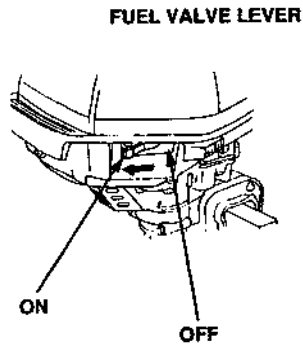

Recoil Starter Grip

Pull the starter grip to operate the recoil starter for starting the engine manually.

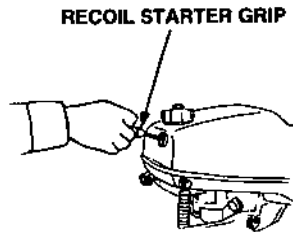

CONTROLS & FEATURES

Steering Friction Bolt

The steering friction bolt adjusts steering resistance.

Turn the bolt clockwise to increase friction for holding a steady course while cruising or to prevent the outboard motor from swinging while trailering the boat.

Turn the bolt counterclockwise to reduce steering friction.

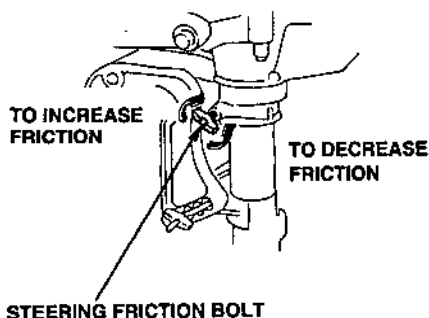

Tilt Lever

The tilt lever enables the outboard motor to be raised for shallow water operation, beaching, launching, or mooring.

To tilt raise the outboard motor using the handle on the engine cover. The spring-loaded tilt lever will automatically move into position and hold the outboard motor when it reaches approximately 75°.

To return the outboard motor to the normal RUN position, hold the outboard motor and pull the tilt lever, then slowly lower the outboard motor.

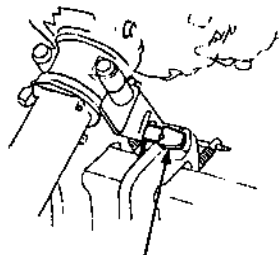
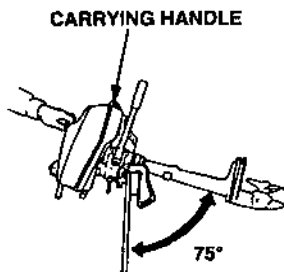

TILT LEVER

CONTROLS & FEATURES

Transom Angle Adjusting Bolt

The transom angle adjusting bolt is used to adjust the angle of the outboard motor in the normal operating position (see page 19).

Loosen the wing nut to free the adjusting bolt.

Adjust the angle of the outboard motor, and tighten the wing nut. Be sure that the bolt head and wing nut are seated in one of the four recesses in the adjustment slot.

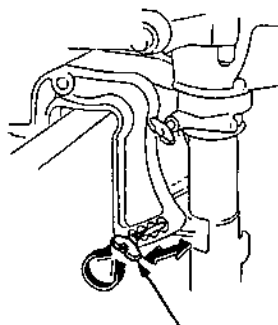

ADJUSTING BOLT AND WING NUT

Fuel Cap Vent Knob

The cap is provided with a vent knob to seal the fuel tank. Open the vent knob 2 or 3 turns before operating the outboard motor (see page 23).

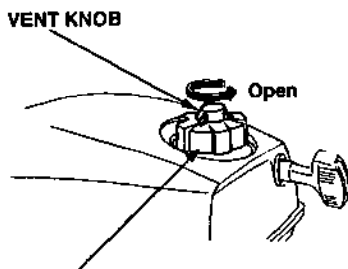

FUEL FILLER CAP

CONTROLS & FEATURES

FEATURES

Water Check Hole

Water should flow from the water check hole while the engine is running. This shows that water is circulating through the engine cooling system (see page 25).

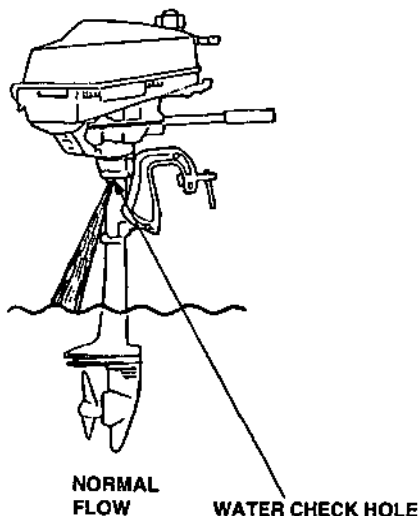

Anode

The anode is a sacrificial material which helps to protect the outboard motor from corrosion.

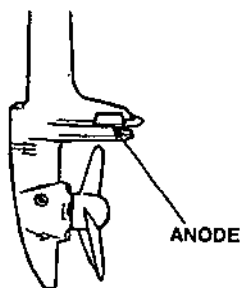

INSTALLATION

It is your responsibility to choose a boat suitable for the engine.

⚠ WARNING

Do not exceed the boat manufacturer's power recommendation. Damage and injury may result.

INSTALLATION POSITION

Install at the stern, at the center line of the boat.

INSTALLATION HEIGHT

For proper propeller depth and engine cooling, the boat's transom height must match the motor's shaft length.

This outboard motor is intended for use with boats that have a transom height of: 15.0 in (380 mm)

Once the boat is in the water and loaded, check proper motor depth by looking at the anticavitation plate: with the motor not running, the plate should be below the surface of the water.

It should be about: 3.9 in (100 mm)

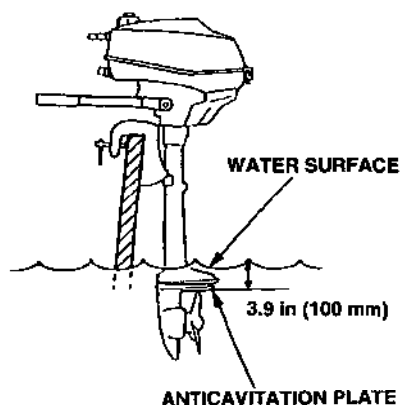
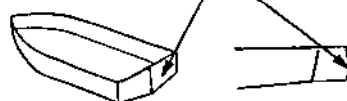
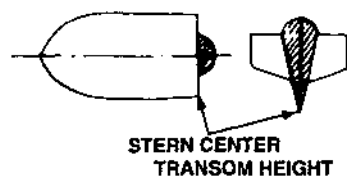

NOTICE

Running the outboard motor without sufficient cooling water will damage the water pump and overheat the engine.

INSTALLATION

OUTBOARD MOTOR ATTACHMENT

Attach the stern bracket to the transom and tighten the clamp screws.

NOTICE

- Before operating the boat, check the tightness of the clamp screws.
- Tie a rope through the hole in the stern bracket and secure the other end of the rope to the boat. This will prevent accidental loss of the motor.

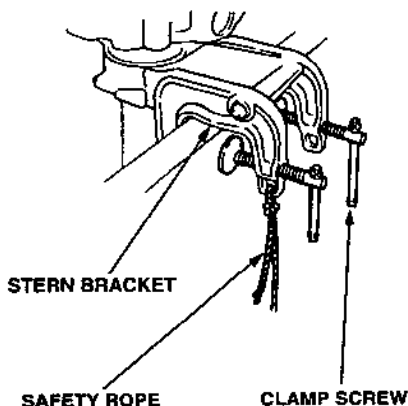

MOTOR ANGLE FOR CRUISING

Adjust the motor so the propeller shaft is parallel with the water surface.



INCORRECT
CAUSES BOAT TO "SQUAT"

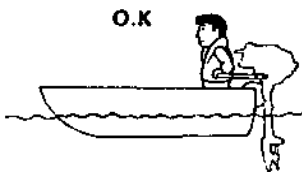

CORRECT
GIVES MAXIMUM PERFORMANCE



INCORRECT
CAUSES BOAT TO "PLOW"

MOTOR ANGLE ADJUSTMENT

If the propeller shaft is not parallel with the water surface, adjust by changing the transom angle adjusting bolt position.

There are four adjusting stages.

1. Loosen the wing nut to free the adjusting bolt.
2. Adjust the angle of the motor, and tighten the wing nut. Be sure that the bolt head and wing nut are seated in one of the four recesses on the adjustment slot.

NOTICE

To prevent damage to the motor or boat, make sure the transom angle adjusting bolt is locked.

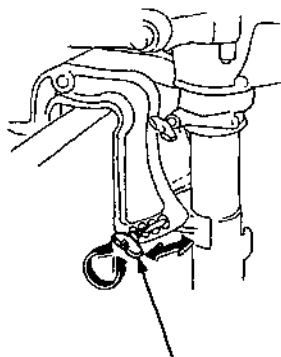

ADJUSTING BOLT AND WING NUT

BEFORE OPERATION

ARE YOU READY TO GET UNDERWAY?

Your safety is your responsibility. A little time spent in preparation will significantly reduce your risk of injury.

Knowledge

Read and understand this manual. Know what the controls do and how to operate them.

Familiarize yourself with the outboard motor and its operation before you get under way. Know what to do in case of emergencies.

Familiarize yourself with all laws and regulations relating to boating and the use of outboard motors.

Safety Apparel

Always wear a PERSONAL FLOTATION DEVICE (PFD) while on the boat.

IS YOUR OUTBOARD MOTOR READY TO GO?

For your safety, and to maximize the service life of your equipment, it is very important to take a few moments before you operate the outboard motor to check its condition. Be sure to take care of any problem you find, or have your servicing dealer correct it, before you operate the outboard motor.

WARNING

Improperly maintaining this outboard motor, or failing to correct a problem before operation, could cause a malfunction in which you could be seriously injured.

Always perform a preoperation inspection before each operation, and correct any problem.

BEFORE OPERATION

Safety Inspection

- Look around for signs of oil or gasoline leaks. Make sure the fuel filler cap and cap gasket are in good condition. Wipe up any spills before starting the engine.
- Check the stern bracket to be sure the outboard motor is securely installed.
- Check that all controls are operating properly.
- Replace any damaged parts.
- Check that all fasteners are in place and securely tightened.

Maintenance Inspection

- Check the engine oil level (see page 41). Running the engine with a low oil level can cause engine damage.
- Check to be sure the propeller is undamaged, and the retaining nut is secured with a cotter pin (see page 50).
- Check that the anode is securely attached to the anticavitation plate and is not excessively worn (see page 49). The anode helps to protect the outboard motor from corrosion.
- Make sure the tool kit and spare parts are onboard (see page 36). Replace any missing items.
- Check the fuel level in the fuel tank (see page 38).

OPERATION

SAFE OPERATING PRECAUTIONS

To safely realize the full potential of this outboard motor, you need a complete understanding of its operation and a certain amount of practice with its controls.

Before operating the outboard motor for the first time, please review the *IMPORTANT SAFETY INFORMATION* on page 7 and the chapter titled *BEFORE OPERATION*.

For your safety, avoid starting or operating the engine in an enclosed area, such as a garage. Your engine's exhaust contains poisonous carbon monoxide gas which can collect rapidly in an enclosed area and cause illness or death.

BREAK-IN PROCEDURE

Proper break-in procedure allows the moving parts to wear in smoothly for best performance and long service life.

For the first 10 hours, run the outboard motor at low speed, and avoid full-throttle operation.

STARTING THE ENGINE

1. Put the emergency engine stop switch clip in the engine stop switch, and attach the lanyard to your wrist.

The engine will not start or run, unless the clip is in the switch.

The emergency engine stop switch clip and lanyard system is a safety device that will stop the engine if you fall away from the controls while operating the boat.

Always attach the lanyard to your wrist before starting the engine.

EMERGENCY ENGINE STOP
SWITCH CLIP

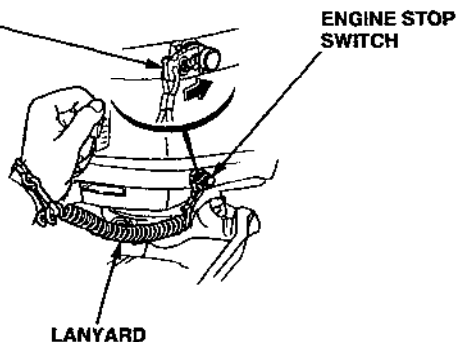

2. Open the fuel tank vent by turning the vent knob at least 2 or 3 turns counterclockwise.

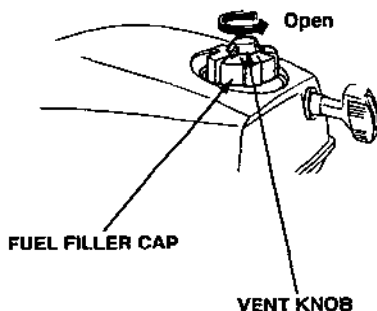

OPERATION

3. Move the fuel value lever to the ON position.

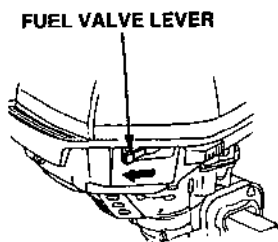

4. Move the throttle lever to the START position.

NOTICE

Do not start the engine with the throttle lever in the FAST position, or the boat will move suddenly when the engine starts.

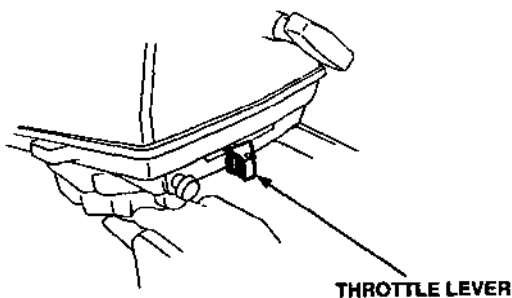

5. To start a cold engine, pull out the choke knob. To restart a warm engine, leave the choke knob pushed in.

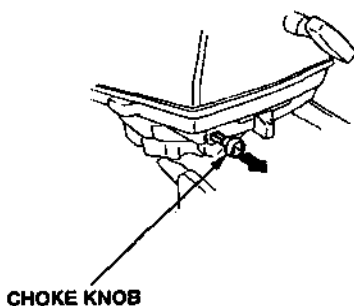

OPERATION

6. Pull the recoil starter grip slowly until you feel resistance, then pull briskly.

NOTICE

- Do not allow the starter grip to snap back against the engine. Return it gently to prevent damage to the starter.
- Do not pull the starter grip while the engine is running, as that may damage the starter.

If the engine fail to start, check the engine stop switch clip.

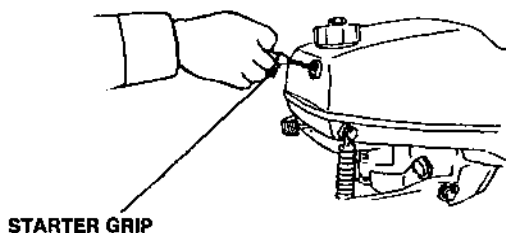

7. After starting, be sure water is flowing out of the water check hole.

NOTICE

If water does not flow out, or if steam comes out, stop the engine. Check to see if the screen in the cooling water inlet is obstructed. Do not operate the engine until the problem has been corrected.

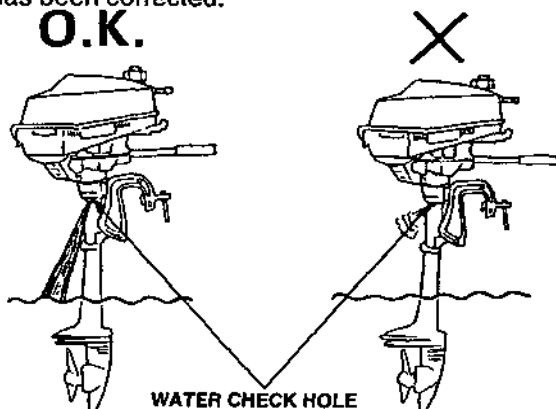

8. If the choke was used, push it in gradually as the engine warms up.

9. Before leaving the dock, check the operation of the engine stop switch.

OPERATION

EMERGENCY STARTING

If the recoil starter is not working properly, the engine can be started with the spare starter rope in the tool kit.

1. Remove the engine cover.
2. Remove the recoil starter by removing the three 6 mm bolts.
3. Follow steps 1 through 5 of the normal engine starting procedure (see pages 23 and 24).
4. Wind the spare rope clockwise around the pulley, and then pull it straight out to start the engine. Keep clear of moving parts.
5. Leave the recoil starter off and reinstall engine cover.

⚠ WARNING

Exposed moving parts can cause injury. Use extreme care when installing the engine cover. Do not operate the outboard motor without the engine cover.

ENGINE COVER

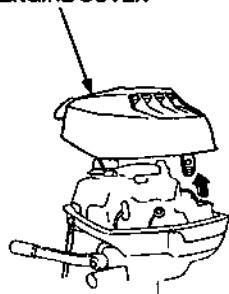

STARTER ROPE

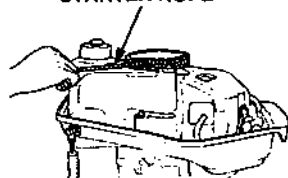

6 mm NUTS

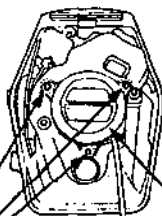

RECOIL STARTER

STOPPING THE ENGINE

Emergency Engine Stopping

Disengage the emergency engine stop switch clip from the engine stop switch by pulling the lanyard.

It is a good idea to stop the engine with the emergency engine stop switch lanyard from time to time to be sure that the switch is operating properly.

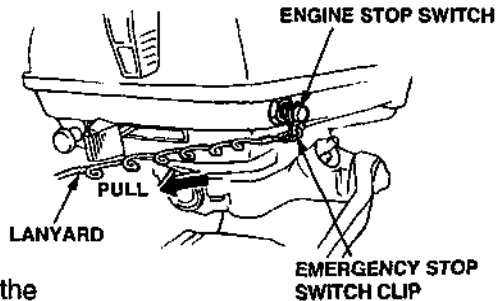

Normal Engine Stopping

1. Move the throttle lever to the SLOW position.

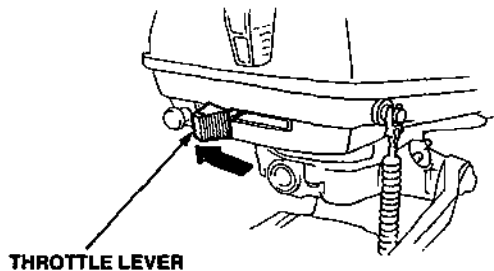

2. Push the engine stop switch button until the engine stops.

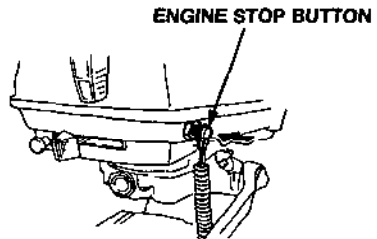

In the event that the engine does not stop when you push the engine stop switch, pull the emergency engine stop switch lanyard. If the engine continues to run, pull the choke knob to stop the engine.

OPERATION

3. Move the fuel valve lever to the OFF position.

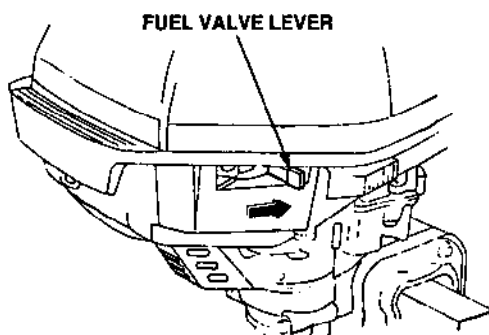

4. Close the fuel tank vent by turning vent knob clockwise.

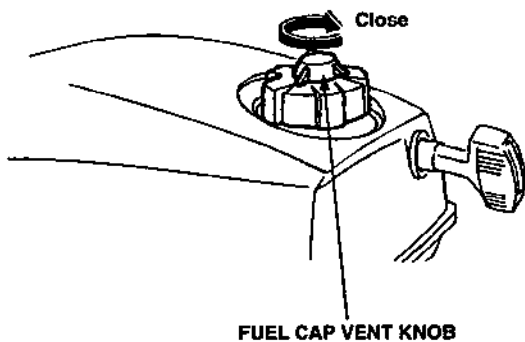

STEERING

To turn to the right, swing the tiller handle to the left. To turn to the left, swing the tiller handle to the right.

Boats equipped with a remote control steering wheel are controlled in the same way as a car.

RIGHT TURN



Swing the tiller handle to the right.

LEFT TURN



Swing the tiller handle to the left.

The steering friction should be adjusted so that stable boat operation is maintained with a minimum of operator effort.

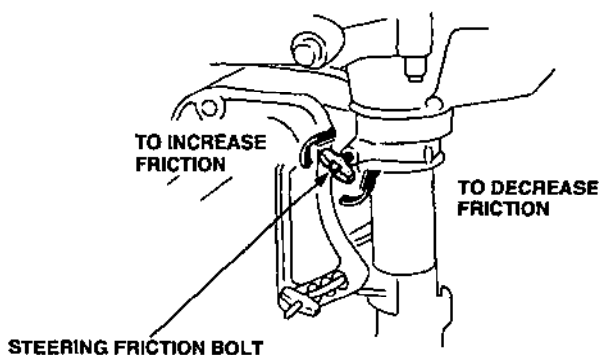

OPERATION

CRUISING

Turn the throttle lever toward FAST to increase speed. For normal cruising, open the throttle about 3/4.

For best performance, passengers and equipment should be distributed evenly to balance the boat.

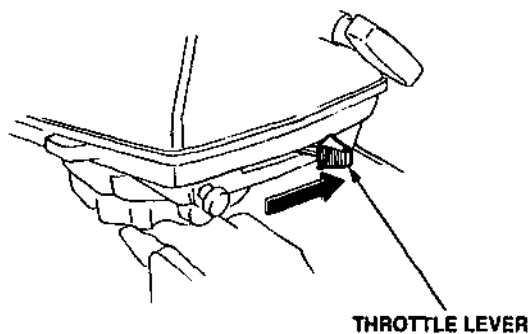

REVERSING THE OUTBOARD MOTOR

1. Move the throttle lever to the SLOW position.

NOTICE

Before rotating the outboard motor (from either forward to reverse or from reverse to forward) reduce the engine speed to SLOW, or the boat could capsize.

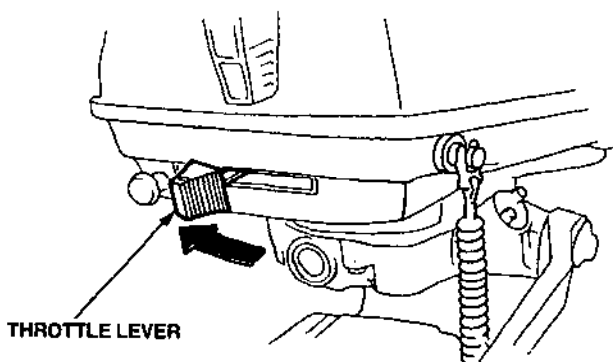

2. To reverse direction, turn the outboard motor 180°, and then pivot the steering handle as shown.

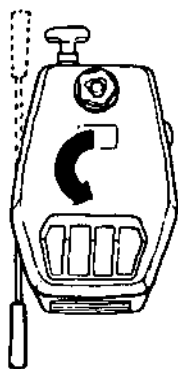

NOTICE

When operating in reverse, proceed with caution to avoid hitting any underwater obstructions with the propeller.

OPERATION

TILTING THE OUTBOARD MOTOR

Tilt the motor prevent the propeller and gear case from hitting bottom when the boat is beached or stopped in shallow water.

1. Stop the engine and turn the fuel valve lever off.
2. Close the fuel tank vent, turn the vent knob clockwise.
3. With the motor in the forward position, raise the outboard motor using the handle on the engine cover. The spring-loaded tilt lever will automatically move into position and hold the outboard motor when it reaches approximately 75°.
4. Adjust the steering friction bolt to keep the motor from moving.

NOTICE

- If the motor is tilted in the reverse position, crankcase oil will enter the cylinder and may cause difficult starting or may prevent the engine from being cranked.
 - Do not use the tiller handle to tilt the outboard motor.
5. To return the outboard motor to the normal RUN position, hold the outboard motor by the handle on the engine cover and pull the tilt level toward you, then lower the outboard motor slowly.

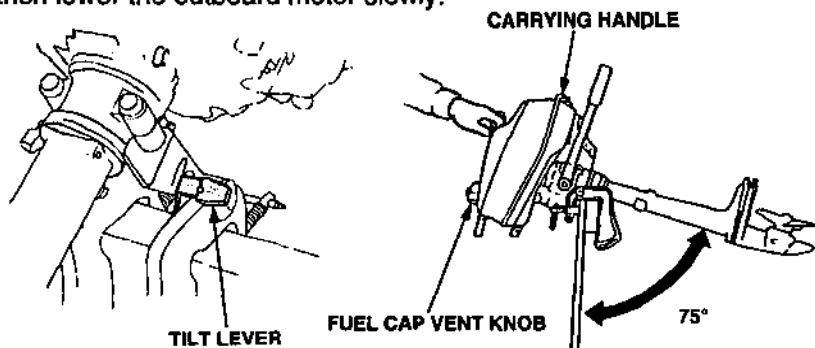

NOTICE

- Make sure water comes out from the cooling water check hole.
- When the outboard motor is tilted, cruise at low speed.

OPERATION

NOTICE

To avoid damaging the motor, be very careful when mooring a boat, especially when its motor is tilted up. Don't allow the motor to strike against the pier or other boats.

NO

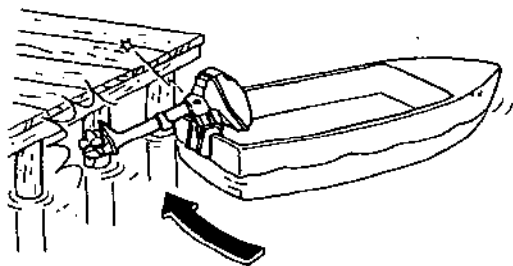

SERVICING YOUR HONDA OUTBOARD MOTOR

THE IMPORTANCE OF MAINTENANCE

Good maintenance is essential for safe, economical, and trouble-free operation. It will also help reduce air pollution.

▲ WARNING

Improperly maintaining this outboard motor, or failure to correct a problem before operation, can cause a malfunction in which you can be seriously hurt or killed.

Always follow the inspection and maintenance recommendations and schedules in this owner's manual.

To help you properly care for your outboard motor, the following pages include a maintenance schedule, routine inspection procedures, and simple maintenance procedures using basic hand tools. Other service tasks that are more difficult, or require special tools, are best handled by professionals and are normally performed by a Honda technician or other qualified mechanic.

The maintenance schedule applies to normal operating conditions. If you operate your outboard motor under unusual conditions, consult an authorized Honda marine dealer for recommendations applicable to your individual needs and use.

Remember that your authorized Honda marine dealer knows your outboard motor best and is fully equipped to maintain and repair it.

To ensure the best quality and reliability, use only new, genuine Honda parts or their equivalents for repair and replacement.

Maintenance, replacement, or repair of emission control devices and systems may be performed by any engine repair establishment or individual, using parts that are "certified" to EPA standards.

SERVICING YOUR HONDA OUTBOARD MOTOR

MAINTENANCE SAFETY

Some of the most important safety precautions follow. However, we cannot warn you of every conceivable hazard that can arise in performing maintenance. Only you can decide whether or not you should perform a given task.

▲ WARNING

Failure to properly follow maintenance instructions and precautions can cause you to be seriously hurt or killed.

Always follow the procedures and precautions in the owner's manual.

Safety Precautions

- Make sure the engine is off before you begin any maintenance or repairs. This will eliminate several potential hazards:
 - **Carbon monoxide poisoning from engine exhaust.**
Be sure there is adequate ventilation whenever you operate the engine.
 - **Burns from hot parts.**
Let the engine and exhaust system cool before touching.
 - **Injury from moving parts.**
Do not run the engine unless instructed to do so.
- Read the instructions before you begin, and make sure you have the tools and skills required.
- To reduce the possibility of fire or explosion, be careful when working around gasoline. Use only a nonflammable solvent, not gasoline, to clean parts. Keep cigarettes, sparks, and flames away from all fuel-related parts.

SERVICING YOUR HONDA OUTBOARD MOTOR

TOOL KIT AND SPARE PARTS

The following tools and spare parts are supplied with the outboard motor for maintenance, adjustment, and emergency repairs.

Spare shear pins and cotter pins are located near the oil filler cap inside the engine cover.

Tool Kit

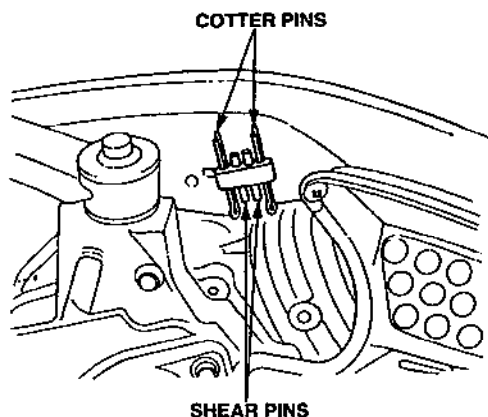
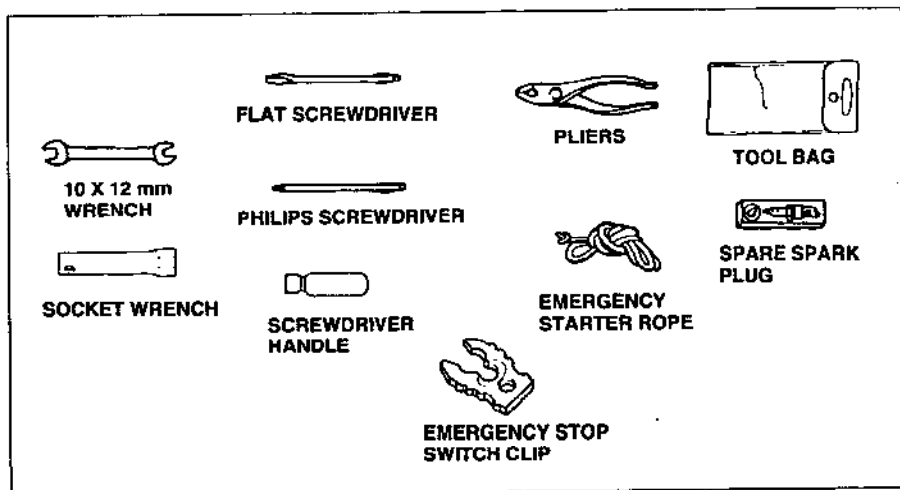

SERVICING YOUR HONDA OUTBOARD MOTOR

MAINTENANCE SCHEDULE

REGULAR SERVICE PERIOD (3)		EACH USE	FIRST MONTH OR 20 HRS	EVERY 6 MONTHS OR 100 HRS	EVERY YEAR OR 200 HRS.
ITEM	Perform at every indicated month or operating hour intervals, whichever comes first.				
•	Engine oil	Check level	○		
		Change		○	○
	Gear case oil	Check level		○	
		Change		○	○
		Check for water contamination		○	
	Starter rope	Check		○	
	Carburetor linkage	Check	○ (2)	○ (2)	
•	Valve clearance	Check-Readjust	○ (2)		○ (2)
•	Spark plug	Check-Clean		○	
	Shear pin	Check		○	
	Propeller (cotter pin)	Check	○		
	Anode	Check	○		
	Lubrication	Grease	○ (1)	○ (1)	
	Fuel tank and filter	Clean			○
•	Thermostat	Check			○ (2)
	Fuel filter	Change			○
	Combustion chamber and valves	Clean-Relap		Every 300 hours (2)	
•	Fuel line	Check (Replace if necessary)	○	Every 2 years (2)	

- Emission-related items.

NOTE: (1) Lubricate more frequently when used in salt water.
 (2) These items should be serviced by an authorized Honda marine dealer, unless the owner has the proper tools and is mechanically proficient. See the Honda Shop Manual.
 (3) For professional commercial use, log hours of operation to determine proper maintenance intervals.

SERVICING YOUR HONDA OUTBOARD MOTOR

REFUELING

Fuel tank capacity: 0.26 US gal (1.0 l, 0.22 Imp gal)

With the engine stopped, turn the vent knob counterclockwise to the open position and remove the fuel filler cap.

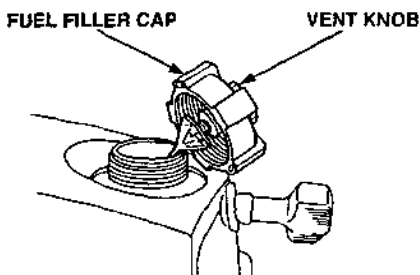

Refill the fuel tank if the fuel level is low.

⚠ WARNING

Gasoline is highly flammable and explosive.

You can be burned or seriously injured when handling fuel.

- **Stop the engine and keep heat, sparks, and flame away.**
- **Handle fuel only outdoors.**
- **Wipe up spills immediately.**

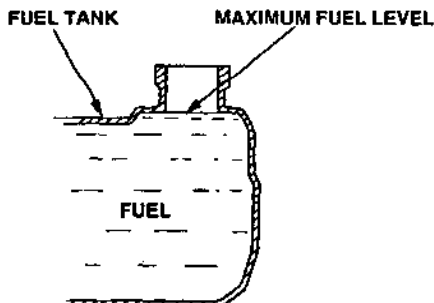

Refuel in a well-ventilated area before starting the engine. If the engine has been running, allow it to cool. Refuel carefully to avoid spilling fuel. Inspect the condition of the fuel filler cap gasket and replace if necessary.

After refilling, install and tighten the fuel filler cap securely. Turn the vent knob clockwise to the closed position.

Spilled fuel is not only a fire hazard, it causes environmental damage. Wipe up spills immediately.

NOTICE

Fuel can damage paint and plastic. Be careful not to spill fuel when filling your fuel tank. Damage caused by spilled fuel is not covered under warranty.

SERVICING YOUR HONDA OUTBOARD MOTOR

FUEL RECOMMENDATIONS

Use unleaded gasoline with a pump octane rating of 86 or higher.

This outboard motor is certified to operate on unleaded gasoline. Unleaded gasoline produces fewer engine and spark plug deposits and extends exhaust system life.

Never use stale or contaminated gasoline or an oil/gasoline mixture. Avoid getting dirt or water in the fuel tank.

Occasionally you may hear light "spark knock" or "pinging" (metallic rapping noise) while operating under heavy loads. This is no cause for concern.

If spark knock or pinging occurs at a steady engine speed, under normal load, change brands of gasoline. If spark knock or pinging persists, see an authorized Honda marine dealer.

NOTICE

Running the engine with persistent spark knock or pinging can cause engine damage.

Running the engine with persistent spark knock or pinging is misuse, and the Distributor's Limited Warranty does not cover parts damaged by misuse.

SERVICING YOUR HONDA OUTBOARD MOTOR

COOLING SYSTEM CLEANING AND FLUSHING

After each use in salt water or dirty water, thoroughly clean and flush the outboard motor.

⚠ WARNING

- For safety, the propeller must be removed.
- Be sure the outboard motor is securely mounted, and do not leave it unattended while running.
- Keep children and pets away from the area, and stay clear of moving parts during this procedure.

NOTICE

Running the engine without water can cause serious engine damage due to overheating. Be sure that water flows from the water check hole while the engine is running. If not, stop the engine and determine the cause of the problem.

1. Wash the outside of the outboard motor with clean, fresh water.
2. Remove the propeller.
3. Stand the motor in a suitable container of water. The water level must be at least 2 inches above the anticavitation plate.
4. Start the engine and run slowly for at least 10 minutes.

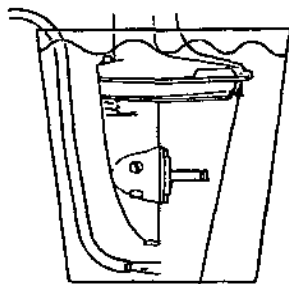

ANTICAVITATION PLATE

SERVICING YOUR HONDA OUTBOARD MOTOR

ENGINE OIL LEVEL CHECK

Check the engine oil level with the engine stopped and the outboard motor in a vertical position.

1. Check the oil level shown on the oil level inspection window.
2. If the oil level is near or below the lower limit mark on the window, fill with the recommended oil (see page 43) to the upper limit mark on the dipstick.

Insert and remove the dipstick without screwing it into the filler neck. Check the oil level shown on the dipstick. Fill to the upper limit mark.

NOTICE

Running the engine with a low oil level can cause engine damage.

3. Install the oil filler cap and tighten it securely.
4. Install the engine cover.

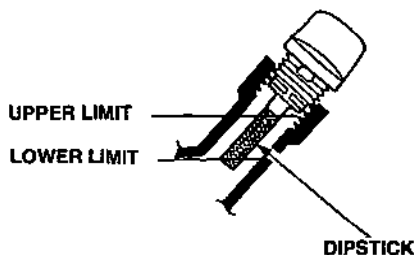
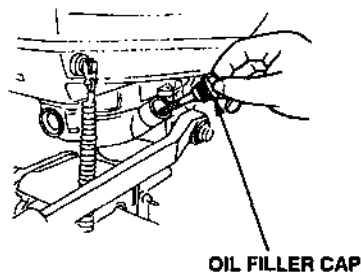
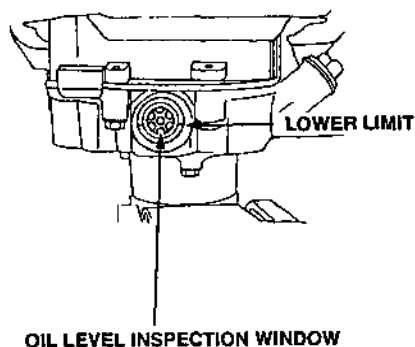

SERVICING YOUR HONDA OUTBOARD MOTOR

ENGINE OIL CHANGE

Drain the used oil while the engine is warm. Warm oil drains quickly and completely.

1. Move the fuel valve lever to the OFF position, and turn the fuel vent knob clockwise to the CLOSE position.
2. Remove the oil filler cap, and turn the motor on its side to drain the oil.

NOTICE

Improper disposal of engine oil can be harmful to the environment. If you change your own oil, please dispose of the used oil properly. Put it in a sealed container, and take it to a recycling center. Do not discard it in a trash bin or dump it on the ground.

3. Stand the outboard motor in a vertical position, fill to the upper limit mark on the dipstick with the recommended oil (p. 43).

Engine oil capacity: 0.42 US qt (0.40 l, 0.35 Imp qt)

4. Install the oil filler cap and tighten it securely.

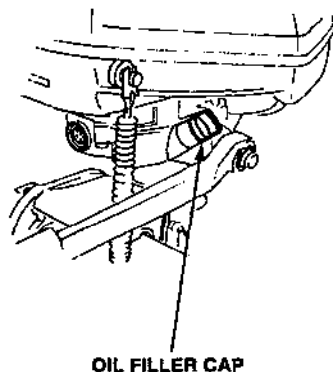
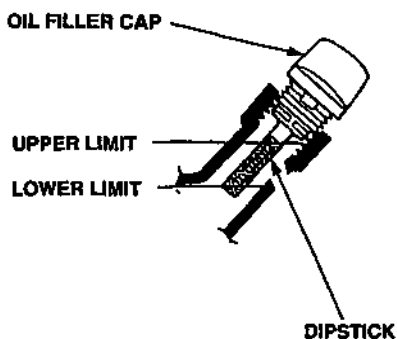

SERVICING YOUR HONDA OUTBOARD MOTOR

ENGINE OIL RECOMMENDATIONS

Oil is a major factor affecting performance and service life. Use 4-stroke automotive detergent oil.

SAE 10W-30 is recommended for general use. Other viscosities shown in the chart may be used when the average temperature in your area is within the recommended range.

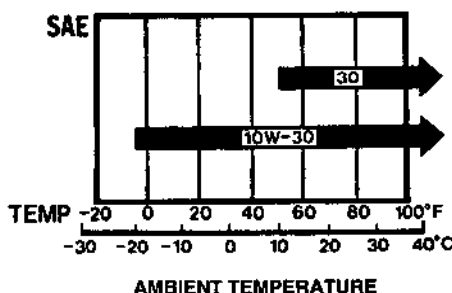

The SAE oil viscosity and service classification are in the API label on the oil container. Honda recommends that you use API SERVICE category SF or SG oil.

SERVICING YOUR HONDA OUTBOARD MOTOR

GEAR OIL LEVEL CHECK

Check the oil level when the motor is in the vertical position. Remove the level plug and see if oil flows out.

If no oil flows out, use a commercially available oil pump or squeeze tube to fill the gear case with gear oil recommended on page 45. Pump or squeeze fresh oil through the OIL DRAIN plug hole until oil begins flowing out through the OIL LEVEL plug hole.

If there is water in the oil, the water will flow out first when the drain plug is removed, or the oil will be a milky color. If water is detected in the oil, the outboard motor should be inspected by an authorized Honda marine dealer.

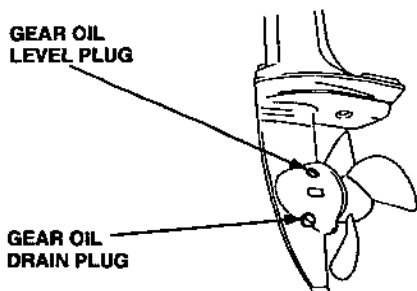

SERVICING YOUR HONDA OUTBOARD MOTOR

GEAR OIL CHANGE

- Recommended oil** : Marine SAE90 hypoid gear oil
API Service Classification (GL-4 or GL-5)
- Oil Capacity** : 0.05 US qt (0.05 ℓ, 0.041 Imp qt)

Remove the level plug and drain plug and allow the gear oil to thoroughly drain into a suitable container.

Pump or squeeze the recommended gear oil through the OIL DRAIN plug hole until oil starts flowing out through the OIL LEVEL plug hole.

Use new sealing washers. Install the oil level plug first and then the oil drain plug. Tighten securely.

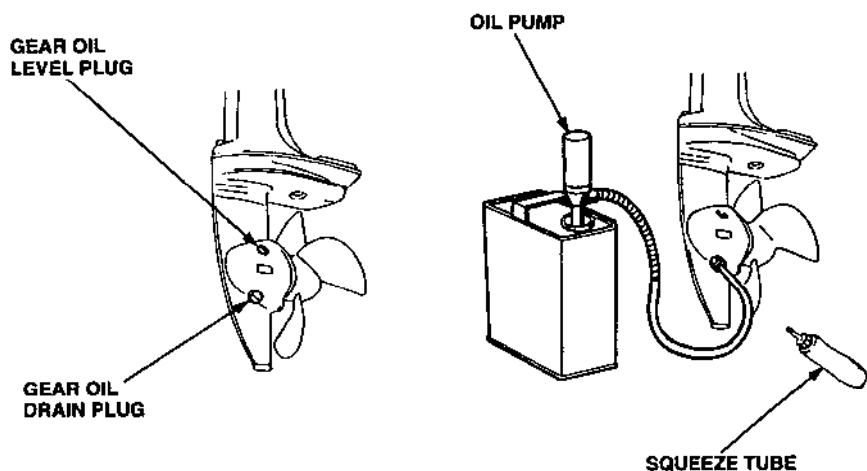

SERVICING YOUR HONDA OUTBOARD MOTOR

LUBRICATION

Apply marine anticorrosion grease to the following areas:

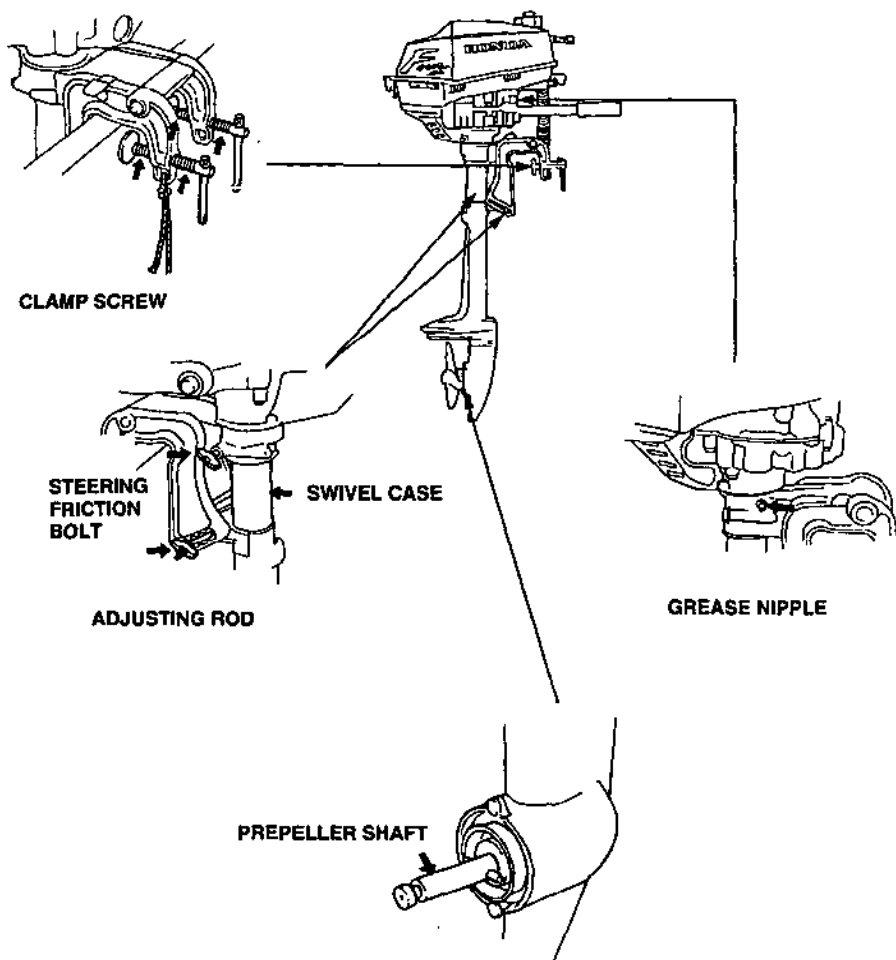

Apply anticorrosion oil to pivot surfaces where grease cannot penetrate.

SERVICING YOUR HONDA OUTBOARD MOTOR

SPARK PLUG SERVICE

Recommended spark plug: BMR-4A (NGK)

1. Remove the engine cover.
2. Remove the spark plug cap.
3. Use the wrench supplied in the tool kit to remove the spark plug.
4. Visually inspect the spark plug. Discard the spark plug if there is apparent wear, or if the insulators are cracked or chipped. Clean the spark plug with a wire brush if they are to be reused.
5. Measure the plug gap with a feeler gauge.
Correct as necessary by carefully bending the side electrode.
The gaps should be: 0.024 – 0.028 in (0.60 – 0.70 mm)

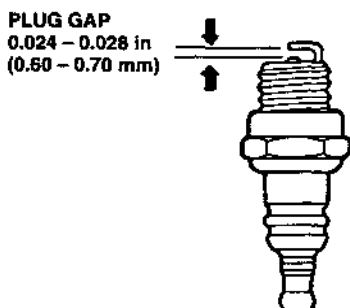
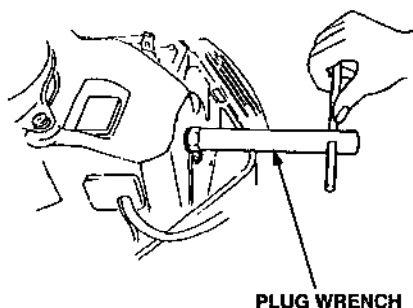

SERVICING YOUR HONDA OUTBOARD MOTOR

6. Check that the spark plug washer are in good condition, and thread the spark plug in by hand to prevent cross-threading.
7. After the spark plug are seated, tighten with a spark plug wrench to compress the washer.

If installing a new spark plug, tighten 1/2 turn after the spark plug seats to compress the washers. If reinstalling a used spark plug, tighten 1/8–1/4 turn after the spark plug seats to compress the washer.

8. Install the engine cover.

NOTICE

- The spark plug must be securely tightened. Improperly tightened plug can become very hot and may cause engine damage.
- Use only the recommended spark plug or equivalent. Spark plug which have an improper heat range may cause engine damage.

SERVICING YOUR HONDA OUTBOARD MOTOR

RECOIL STARTER ROPE INSPECTION

Inspect the recoil starter rope, and replace it if it becomes frayed.

Always keep the tool kit's emergency starter rope onboard in case the recoil starter rope fails.

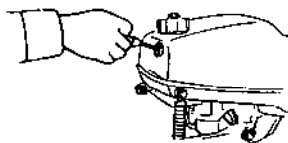

ANODE REPLACEMENT

The anode is a sacrificial material which helps to protect the outboard motor from corrosion.

Replace the anode when it has been reduced to about half its original size, or if it is crumbling.

NOTICE

Painting or coating the anode will defeat its purpose and will lead to rust and corrosion damage to the outboard motor. The anode must be exposed to the water.

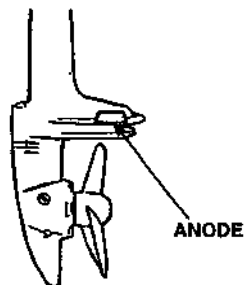

SERVICING YOUR HONDA OUTBOARD MOTOR

SHEAR PIN REPLACEMENT

A shear pin is used to protect the propeller and drive mechanism from damage when the propeller strikes an obstruction.

1. Remove the cotter pin, the propeller cap, and the propeller.
2. Remove the broken shear pin and replace it with a new one.
3. Install the propeller.
4. Install a new cotter pin, and spread the ends as shown in the illustration.

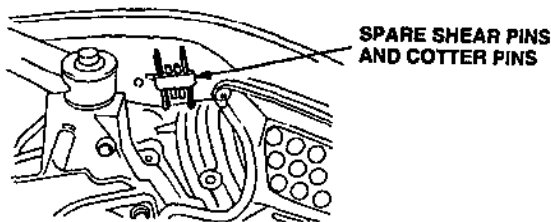
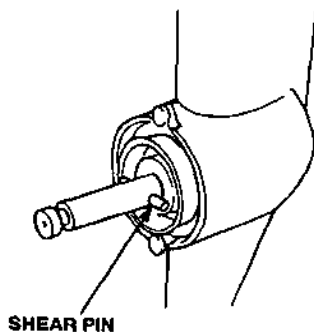
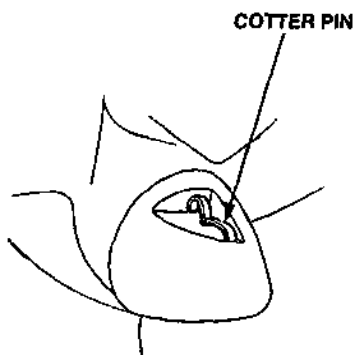

HELPFUL TIPS & SUGGESTIONS

STORING YOUR OUTBOARD MOTOR

Storage Preparation

Proper storage preparation is essential for keeping your pump troublefree and looking good. The following steps will help to keep rust and corrosion from impairing your outboard motor's function and appearance, and will make the engine easier to start when you use the outboard motor again.

Cleaning and Flushing

Wash the outside of the outboard motor with clean, fresh water, and flush the cooling system as described on page 40.

Disengage the emergency engine stop switch clip from the engine stop switch, and pull the recoil starter rope several times to expel any water remaining in the water pump.

Touch up any damaged paint, and coat areas that may rust with a light film of oil. Lubricate controls with a silicone spray lubricant.

Fuel

Gasoline will oxidize and deteriorate in storage. Old gasoline will cause hard starting, and it leaves gum deposits that clog the fuel system. If the gasoline in your fuel tank and carburetor deteriorates during storage, you may need to have the carburetor and other fuel system components serviced or replaced.

The length of time that gasoline can be left in your fuel tank and carburetor without causing functional problems will vary with such factors as gasoline blend, your storage temperatures, and whether the fuel tank is partially or completely filled. The air in a partially filled fuel tank promotes fuel deterioration. Very warm storage/temperatures accelerate fuel deterioration. Fuel deterioration problems may occur within a few months, or even less if the gasoline was not fresh when you filled the fuel tank.

The Distributor's Limited Warranty does not cover fuel system damage or engine performance problems resulting from neglected storage preparation.

HELPFUL TIPS & SUGGESTIONS

1. With the outboard motor in a vertical position, place an approved gasoline container below the fuel drain outlet, and use a funnel to avoid spilling fuel. Turn the fuel filler cap vent knob counterclockwise to the open position.

⚠ WARNING

Gasoline is highly flammable and explosive.

You can be burned or seriously injured when handling fuel.

- Keep heat, sparks, and flame away.
- Handle fuel only outdoors.
- Wipe up spills immediately.

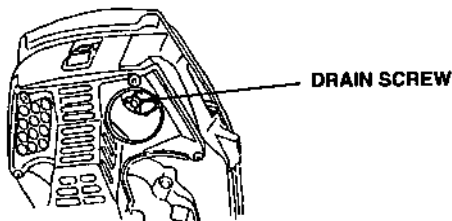

2. Remove the drain screw, then move the fuel valve lever to the on position.
3. After all fuel has drained into the container, reinstall the drain screw. Tighten the float bowl bolt securely.
4. Move the fuel valve lever to the off position and turn the fuel filler cap vent knob clockwise to the close position.

Engine Oil

1. Change the engine oil (see page 42).
2. Remove the spark plugs (see page 47).
3. Pour a tablespoon (5 - 10 cc) of clean engine oil into each cylinder.
4. Pull the starter rope several times to distribute the oil in the cylinders.
5. Reinstall the spark plugs.

HELPFUL TIPS & SUGGESTIONS

Storage Precautions

Select a well-ventilated storage area. If possible, avoid storage areas with high humidity.

If your fuel tank contains gasoline, store it away from any appliance that operates with a flame, such as a furnace, water heater, or clothes dryer. Also avoid any area with a spark-producing electric motor, or where power tools are operated.

Store the outboard motor either vertically, or horizontally with the tiller handle side down, as shown.

If storing horizontally, be sure to fold the tiller handle, so the outboard motor rests on its case protectors. Be sure all water has drained from the outboard motor before placing it on its side, so no residual water can enter the engine exhaust port.

NOTICE

Any other storage position may cause damage or oil leakage.

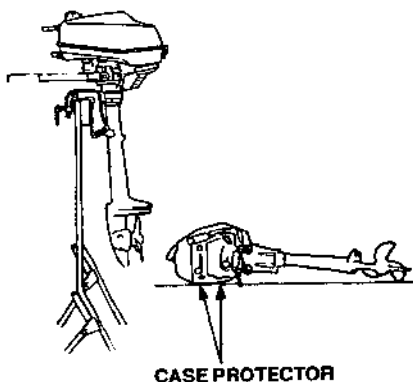

Cover the outboard motor to keep out dust. Do not use sheet plastic as a dust cover. A nonporous cover will trap moisture, promoting rust and corrosion.

HELPFUL TIPS & SUGGESTIONS

Removal From Storage

Check your outboard motor as described in the *BEFORE OPERATION* chapter of this manual.

If the cylinder was coated with oil during storage preparation, the engine may smoke briefly at startup. This is normal.

TRANSPORTING

When trailering a boat with the outboard motor attached, leave the engine in the normal running position, if possible, and tighten the steering friction bolt securely (p. 29).

If there is insufficient road clearance in the normal running position, then tilt the outboard motor, leave the tilt lever in the tilt position, and use a motor support device, such as a transom-saver bar, or remove the outboard motor from the boat.

To transport the outboard motor when removed from the boat, secure it in either the vertical or horizontal position shown on page 53.

To carry, hold the outboard motor by the carrying handle. Do not carry by the engine cover.

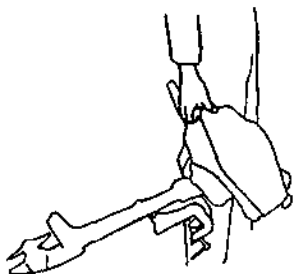

NOTICE

Lifting the outboard motor by the engine cover, or using the installed outboard motor as a handle or lever to move the boat, can damage the outboard motor.

TAKING CARE OF UNEXPECTED PROBLEMS

ENGINE WILL NOT START

1. Is the emergency stop switch clip in place?
2. Is there fuel in the fuel tank?
3. Is the fuel cap vent knob turned to open?
4. Is fuel reaching the carburetor?

Loosen the carburetor drain screw to see if there is fuel in the carburetor float bowl.

⚠ WARNING

If any fuel is spilled, make sure the area is dry before testing the spark plug or starting the engine. Spilled fuel or fuel vapor may ignite.

5. Are the spark plugs firing?
 - a. Remove and inspect the spark plugs. Clean and dry the plugs, and check the electrode gaps (p. 47).
 - b. Install the spark plugs in their caps, and ground the side electrode to any engine ground away from the spark plug holes.
 - c. Pull the recoil starter briskly, and see if the plug sparks.
 - d. If the spark plugs are OK, reinstall them, and try to start the engine.

Engine overheats:

1. Is the water intake screen clogged?

TAKING CARE OF UNEXPECTED PROBLEMS

SUBMERGED MOTOR

A submerged motor must be serviced immediately after it is recovered from the water in order to minimize corrosion.

If there is a Honda marine dealership nearby, take the motor immediately to the dealer. If you are far from a dealership, proceed as follows:

1. Remove the engine cover, and rinse the motor with fresh water to remove salt water, sand, mud, etc.
2. Drain the fuel tank into suitable container.
3. Loosen the carburetor drain screw (p. 52), drain the contents of the carburetor into a suitable container, then tighten the drain screw.
4. Change the engine oil (p. 46). If there was water in the engine crankcase, or the used engine oil showed signs of water contamination, then a second engine oil change should be performed after running the engine for 1/2 hour.
5. Remove the spark plugs. Disengage the emergency engine stop switch clip from the engine stop switch and pull the recoil starter several times to completely expel water from the cylinders.

NOTICE

- When cranking the engine with an open ignition circuit (spark plugs removed from the ignition circuit), disengage the emergency engine stop switch clip from the engine stop switch to prevent electrical damage to the ignition system.
- If the engine was running when it submerged, there may be mechanical damage, such as bent connecting rods. If the engine binds when cranked, do not attempt to run the engine until it has been repaired.

TAKING CARE OF UNEXPECTED PROBLEMS

6. Pour a teaspoon of engine oil into each spark plug hole, then pull the recoil starter several times to lubricate the inside of the cylinders. Reinstall the spark plugs and engage the emergency engine stop switch clip with the engine stop switch.
7. *Attempt to start the engine.*
 - If the engine fails to start, remove the spark plugs, clean and dry the electrodes, then reinstall the spark plugs and attempt to start the engine again.
 - If the engine starts, and no mechanical damage is evident, continue to run the engine for 1/2 hour or longer (be sure the water level is at least 2 inches above the anticavitation plate).
8. As soon as possible, take the motor to a Honda marine dealer for inspection and service.

TECHNICAL & CONSUMER INFORMATION

TECHNICAL INFORMATION

Serial Number Locations

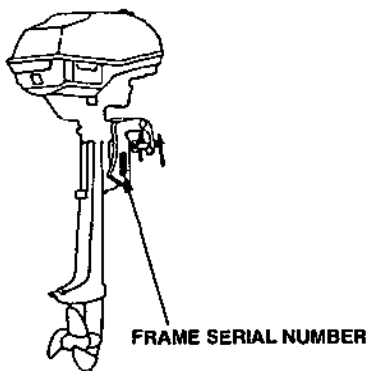
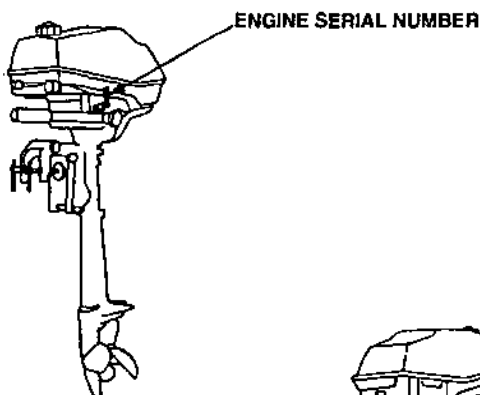

Record the engine and frame serial numbers in the space below. You will need these serial numbers when ordering parts, and when making technical or warranty inquiries (see page 67).

Engine serial number: _____

Frame serial number: _____

TECHNICAL & CONSUMER INFORMATION

Carburetor Modification for High Altitude Operation

At high altitude, the standard carburetor air-fuel mixture will be too rich. Performance will decrease, and fuel consumption will increase. A very rich mixture will also foul the spark plug and cause hard starting.

High altitude performance can be improved by specific modifications to the carburetor. If you always operate your engine at altitudes above 5,000 feet (1,500 meters), have an authorized Honda marine dealer perform this carburetor modification.

Even with carburetor modification, engine horsepower will decrease about 3.5 % for each 1,000-foot (300-meter) increase in altitude. The effect of altitude on horsepower will be greater than this if no carburetor modification is made.

NOTICE

When the carburetor has been modified for high altitude operation, the air-fuel mixture will be too lean for low altitude use. Operation at altitudes below 5,000 feet (1,500 meters) with a modified carburetor may cause the engine to overheat and result in serious engine damage. For use at low altitudes, have an authorized Honda marine dealer return the carburetor to original factory specifications.

TECHNICAL & CONSUMER INFORMATION

Oxygenated Fuels

Some conventional gasolines are being blended with alcohol or an ether compound. These gasolines are collectively referred to as oxygenated fuels. To meet clean air standards, some areas of the United States and Canada use oxygenated fuels to help reduce emissions.

If you use an oxygenated fuel, be sure it is unleaded and meets the minimum octane rating requirement.

Before using an oxygenated fuel, try to confirm the fuel's contents. Some states/provinces require this information to be posted on the pump.

The following are the EPA-approved percentages of oxygenates:

ETHANOL ——— (ethyl or grain alcohol) 10% by volume
You may use gasoline containing up to 10% ethanol by volume. Gasoline containing ethanol may be marketed under the name "Gasohol".

MTBE ————— (Methyl Tertiary Butyl Ether) 15% by volume
You may use gasoline containing up to 15% MTBE by volume.

METHANOL — (methyl or wood alcohol) 5% by volume
You may use gasoline containing up to 5% methanol by volume, as long as it also contains cosolvents and corrosion inhibitors to protect the fuel system. Gasoline containing more than 5% methanol by volume may cause starting and/or performance problems. It may also damage metal, rubber, and plastic parts of your fuel system.

If you notice any undesirable operating symptoms, try another service station, or switch to another brand of gasoline.

Fuel system damage or performance problems resulting from the use of an oxygenated fuel containing more than the percentages of oxygenates mentioned above are not covered under warranty.

TECHNICAL & CONSUMER INFORMATION

Emission Control System Information

Source of Emissions

The combustion process produces carbon monoxide, oxides of nitrogen, and hydrocarbons. Control of hydrocarbons and oxides of nitrogen is very important because, under certain conditions, they react to form photochemical smog when subjected to sunlight. Carbon monoxide does not react in the same way, but it is toxic.

Honda utilizes lean carburetor settings and other systems to reduce the emissions of carbon monoxide oxides of nitrogen, and hydrocarbons.

The U.S. Clean Air Act

EPA regulations require all manufacturers to furnish written instructions describing the operation and maintenance of emission control systems.

The following instructions and procedures must be followed in order to keep the emissions from your Honda engine within the emission standards.

Tampering and Altering

Tampering with or altering the emission control system may increase emissions beyond the legal limit. Among those acts that constitute tampering are:

- Removal or alteration of any part of the intake, fuel, or exhaust systems.
- Alterations that would cause the engine to operate outside its design parameters.

TECHNICAL & CONSUMER INFORMATION

Problems That May Affect Emissions

If you are aware of any of the following symptoms, have your engine inspected and repaired by your servicing dealer.

- Hard starting or stalling after starting.
- Rough idle.
- Misfiring or backfiring under load.
- Afterburning (backfiring).
- Black exhaust smoke or high fuel consumption.

Replacement Parts

The emission control systems on your Honda engine were designed, built, and certified to conform with EPA emission regulations. We recommend the use of genuine Honda parts whenever you have maintenance done. These original-design replacement parts are manufactured to the same standards as the original parts, so you can be confident of their performance. The use of replacement parts that are not of the original design and quality may impair the effectiveness of your emission control system.

A manufacturer of an aftermarket part assumes the responsibility that the part will not adversely affect emission performance. The manufacturer or rebuilder of the part must certify that use of the part will not result in a failure of the engine to comply with emission regulations.

Maintenance

Follow the maintenance schedule on page 37. Remember that this schedule is based on the assumption that your machine will be used for its designed purpose. Sustained high-load or high-temperature operation, or use in unusually wet or dusty conditions, will require more frequent service.

TECHNICAL & CONSUMER INFORMATION

Specifications

Model	BF2A	
Description code	BAES	
Rated Power	1.5 kW (2 HP)	
Full throttle range	4,000 — 5,000 rpm	
Engine type	4-stroke, side valve one cylinder	
Displacement	4.6 cu-in (76 cm ³)	
Spark plug gap	0.024 — 0.028 in (0.60 — 0.70 mm)	
Starter system	Recoil starter	
Ignition system	Transisterized magneto	
Lubrication system	Oil slinger system	
Specified oil	Engine: API standard (SF or SG) SAE 10-30 Gear case: Marine SAE 90 hypoid gear oil API Service Classification (GL-4 or GL-5)	
Oil capacity	Engine: 0.42 US qt (0.40 ℓ, 0.35 Imp qt) Gear case: 0.05 US qt (0.05 ℓ, 0.04 Imp qt)	
Cooling system	Engine: Forced air cooling Exhaust system: Water cooling	
Exhaust system	Underwater exhaust	
Spark plug	BMR-4A (NGK)	
Fuel	Automotive gasoline (91 research octane, 86 pump octane)	
Tank capacity	0.26 US gal (1.0 ℓ, 0.22 Imp gal)	
Steering equipment	Tiller handle	
Tilt angle	75°	
Angle of rotation	360°	
Dimensions,	Length	16.1 in (410 mm)
	Height	36.6 in (930 mm)
	Width	10.8 in (275 mm)
Height from stern bracket to anti-ventilation plate	16.5 in (420 mm)	
Standard propeller (No. of blades-diameter x pitch)	7-1/4 x 4-3/4 in (3-184 x 120 mm)	
Dry weight	27.6 lbs (12.5 kg)	

Honda outboards are power rated in accordance with NMMA procedures and using the ICOMIA standard 28/23.

TECHNICAL & CONSUMER INFORMATION

Tuneup

Spark plug gap	0.024-0.028 in (0.60-0.70 mm)	See page 47.
Idle speed	1,100 \pm 50 rpm	See shop manual.
Valve clearance (cold)	Intake: 0.12 \pm 0.02 mm Exhaust: 0.20 \pm 0.02 mm	See shop manual.
Other specifications	No other adjustments needed.	

TECHNICAL & CONSUMER INFORMATION

WIRING DIAGRAMS

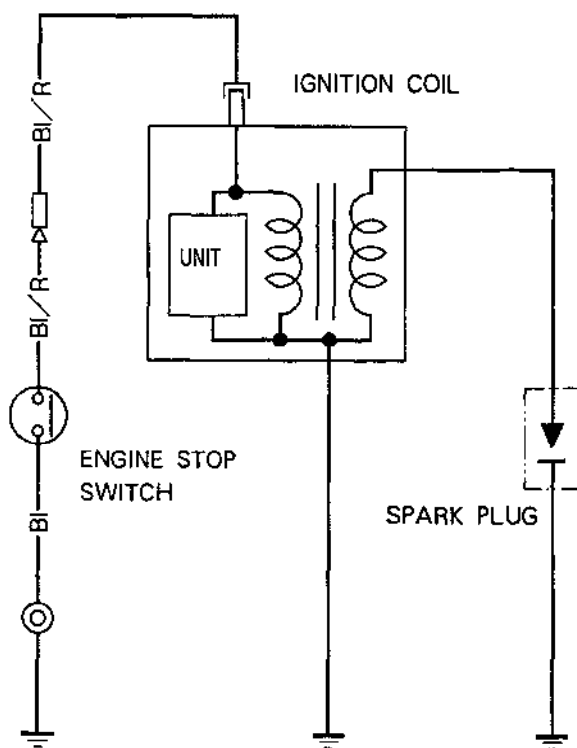

TECHNICAL & CONSUMER INFORMATION

CONSUMER INFORMATION

Honda Publications

These publications will give you additional information for maintaining and repairing your engine. You may order them from your Honda marine dealer.

Shop Manual

This manual covers complete maintenance and overhaul procedures. It is intended to be used by a skilled technician.

Parts Catalog

This manual provides complete, illustrated parts lists.

TECHNICAL & CONSUMER INFORMATION

Warranty Service Information

Honda marine dealership personnel are trained professionals. They should be able to answer any question you may have. If you encounter a problem that your dealer does not solve to your satisfaction, please discuss it with the dealership's management. The Service Manager or General Manager can help. Almost all problems are solved in this way.

If you are dissatisfied with the decision made by the dealership's management, contact the Honda Marine Customer Relations Office. You can write:

American Honda Motor Co., Inc.
Marine Division
Customer Relations Office
4475 River Green Parkway
Duluth, Georgia 30096-2565

Or telephone: (770) 497-6400

When you write or call, please give us this information:

- Model and serial number (see page 58)
- Name of the dealer who sold the outboard motor to you
- Name and address of the dealer who services your outboard motor
- Date of purchase
- Your name, address, and telephone number
- A detailed description of the problem

Current customer service contact information:

Your owner's manual was written to cover most of the questions you might ask about your Honda. Any questions not answered in the owner's manual can be answered by your Honda dealer. If your dealer doesn't have an immediate answer, they should be able to get it for you.

If you have a difference of opinion with your dealer, please remember that each dealership is independently owned and operated. That's why it's important to work to resolve any differences at the dealership level. If the service personnel are unable to assist you, please discuss your concerns with the dealer management such as the Service Manager or the dealership's owner.

If you need to contact American Honda regarding your experiences with your Honda product or with your dealer, please send your comments to the following address:

American Honda Motor Co., Inc.
Marine Division
Customer Relations Office
4900 Marconi Drive
Alpharetta, GA 30005-8847

Or telephone: (770) 497-6400 M-F, 8:30 am - 7:00 pm EST

When you write or call, please provide the following information:

- Your name, address and telephone number (complete with area code)
- Model and complete serial number
- Date of purchase
- Name and location of the selling dealer
- Name and location of the servicing dealer (if different)
- A detailed description of your concerns

INDEX

A	
Anode	16
ANODE REPLACEMENT	49
B	
BEFORE OPERATION	20
ARE YOU READY TO GET UNDER WAY?	20
Knowledge	20
Safety Apparel	20
IS YOUR OUTBOARD MOTOR READY TO GO?	20
Maintenance Inspection	21
Safety Inspection	21
BREAK-IN PROCEDURE	22
C	
Choke Knob	12
CONTENTS	3
CONTROLS & FEATURES	10
COMPONENT & CONTROL LOCATIONS	10
CONTROLS	10
Choke Knob	12
Engine Stop Switch	12
Fuel Cap Vent Knob	15
Fuel Valve Lever	13
Recoil Starter Grip	13
Steering Friction Bolt	14
Throttle Lever	13
Tilt Lever	14
Transom Angle Adjusting Bolt	15
FEATURES	16
Anode	16
Water Check Hole	16
CONSUMER INFORMATION	66
COOLING SYSTEM CLEANING AND FLUSHING	40
CRUISING	30
Carbon Monoxide Hazard	8
E	
EMERGENCY STARTING	26
ENGINE OIL CHANGE	42
ENGINE OIL LEVEL CHECK	41
ENGINE OIL RECOMMENDATIONS	43
ENGINE WILL NOT START	55
Emergency Engine Stopping	27
Emission Control System Information	61
Engine Stop Switch	12

F	
FEATURES	16
Anode	16
Water Check Hole	16
FUEL RECOMMENDATIONS	39
Fuel Cap Vent Knob	15
G	
GEAR OIL CHANGE	45
GEAR OIL LEVEL CHECK	44
H	
HELPFUL TIPS AND SUGGESTIONS	51
STORING YOUR OUTBOARD MOTOR	51
Removal From Storage	54
Storage Precautions	53
Storage Preparation	51
Honda Publications	66
I	
INTRODUCTION	1
IMPORTANT SAFETY INFORMATION	7
INDEX	68
INSTALLATION	17
INSTALLATION HEIGHT	17
INSTALLATION POSITION	17
MOTOR ANGLE ADJUSTMENT	19
MOTOR ANGLE FOR CRUISING	18
OUTBOARD MOTOR ATTACHMENT	18
L	
LUBRICATION	46
M	
Maintenance Inspection	21
MAINTENANCE SAFETY	31
Safety Precautions	31
MAINTENANCE SCHEDULE	37
MOTOR ANGLE ADJUSTMENT	19
MOTOR ANGLE FOR CRUISING	18
N	
Normal Engine Stopping	27

INDEX

O	
OPERATION	22
BREAK-IN PROCEDURE	22
CRUISING	30
EMERGENCY STARTING	26
REVERSING THE OUTBOARD MOTOR	31
SAFE OPERATING PRECAUTIONS	22
STARTING THE ENGINE	23
STEERING	29
STOPPING THE ENGINE	27
Emergency Engine Stopping	27
Normal Engine Stopping	27
TILTING THE OUTBOARD MOTOR	32
OUTBOARD MOTOR ATTACHMENT	18
Oxygenated Fuels	60
Q	
QUICK REFERENCE INFORMATION	Inside back cover
R	
Recoil Starter Grip	13
RECOIL STARTER ROPE INSPECTION	49
REFUELING	38
Removal From Storage	54
REVERSING THE OUTBOARD MOTOR	31
S	
SAFE OPERATING PRECAUTIONS	22
SAFETY, A FEW WORDS ABOUT	2
Safety Inspection	21
SAFETY, OUTBOARD MOTOR	2
IMPORTANT SAFETY INFORMATION	7
Carbon Monoxide Hazard	8
Operating Responsibility	7
Refuel With Care	8
SAFETY LABEL LOCATIONS	9
SHEAR PIN REPLACEMENT	50
SPARK PLUG SERVICE	47
STARTING THE ENGINE	23
STEERING	29
STOPPING THE ENGINE	27
STORING YOUR OUTBOARD MOTOR	51
Serial Number Locations	58
Specifications	62
Steering Friction Bolt	14
Storage Precautions	53

INDEX

Storage Preparation	51
SUBMERGED MOTOR	56

T

TAKING CARE OF UNEXPECTED PROBLEMS	55
TECHNICAL & CONSUMER INFORMATION	58
TECHNICAL INFORMATION	58
THE IMPORTANCE OF MAINTENANCE	30
Throttle Lever	13
TILTING THE OUTBOARD MOTOR	32
Tilt Lever	14
TOOL KIT AND SPARE PARTS	36
TRANSPORTING	54
Transom Angle Adjusting Bolt	15

W

Warranty Service Information	67
Water Check Hole	16
WIRING DIAGRAMS	65

MEMO

QUICK REFERENCE INFORMATION

Fuel	Type	Unleaded gasoline with a pump octane rating of 86 or higher (page 42)
	Capacity	0.26 US gal (1.0 ℓ)
Engine Oil	Type	SAE 10W-30, API SF or SG, for general use (page 43)
	Capacity	0.42 US qt (0.40 ℓ)
Gear Oil	Type	Marine SAE 90 hypoid, API GL-4 or GL-5
	Capacity	0.05 US qt (0.05 ℓ)
Spark Plug	Type	BMR-4A (NGK)
	Gap	0.024–0.028 in (0.60–0.70 mm) (page 47)
Carburetor	Idle speed	1,100 ± 50 rpm
Maintenance	Before each use	Check engine oil level (page 41). Check propeller and cotter pin (page 50). Check anode (page 49)
	First 20 hours	Change engine oil (page 42). Change gear oil (page 45). Check carburetor linkage. Check/adjust valve clearance. Grease lubrication points (page 46).
	Subsequent	Refer to the maintenance schedule on page 37.

HONDA

31ZV0630
00X31-ZV0-6300



Printed on
Recycled Paper

POM62850-CVR



00559801

PRINTED IN U.S.A.