

HONDA

Power

Equipment

Owner's Manual

Outboard Motor

BF2A





Thank you for purchasing a Honda Outboard Motor.

This manual covers operation and maintenance of the Honda BF2A Outboard Motor. All information in this publication is based on the latest product information available at the time of approval for printing. Honda Motor Co., Ltd. reserves the right to make changes at any time without notice and without incurring any obligation.

No part of this publication may be reproduced without written permission.

This manual should be considered a permanent part of the Outboard Motor and should remain with the Outboard Motor when it is sold.

Pay special attention to statements preceded by the following words:

⚠ DANGER: Indicates severe personal injury or death will result if instructions are not followed.

⚠ WARNING Indicates a strong possibility of severe personal injury or death if instructions are not followed.

CAUTION: Indicates a possibility of personal injury or equipment damage if instructions are not followed.

NOTE: Gives helpful information.

If a problem should arise, or if you have any questions about the Outboard Motor, consult an authorized Honda dealer.

CONTENTS

1. SAFETY	3
2. COMPONENT IDENTIFICATION	5
3. INSTALLATION	7
4. PRE-OPERATION CHECKS	9
5. STARTING THE ENGINE	13
6. OPERATION	18
7. STOPPING THE ENGINE	24
8. MAINTENANCE	26
9. TRANSPORTING/STORAGE	35
10. TROUBLESHOOTING	37
11. SPECIFICATIONS	38
12. OPTIONAL PART	39
13. WARRANTY SERVICE	40

SAFETY LABEL LOCATIONS

Read all safety instructions before using the Outboard Motor.

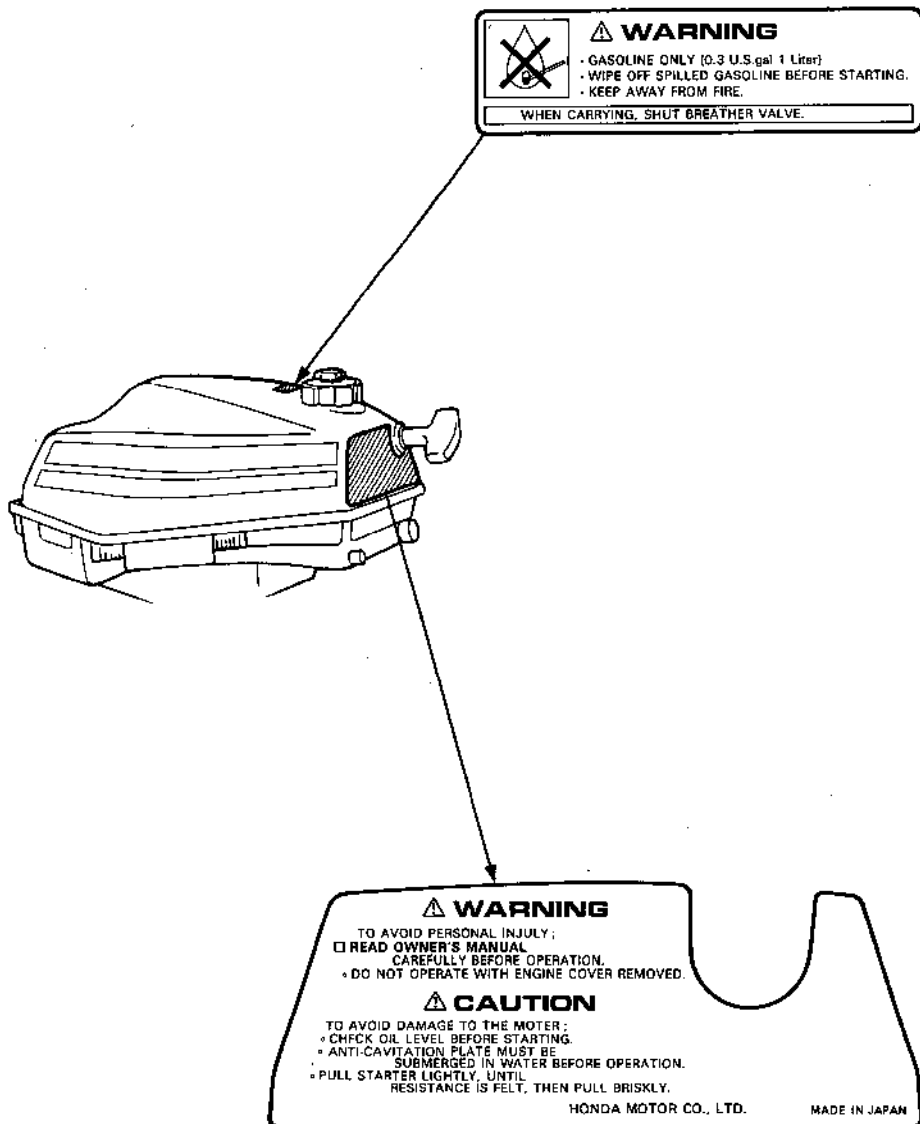

▲ WARNING Honda Outboard motors are designed to give safe dependable service if operated according to instructions. Read and understand the Owner's Manual before operating the Outboard Motor. Failure to do so could result in personal injury or equipment damage.

To ensure safe operation—

- Understand the operation of all controls, and know how to stop the engine quickly—**READ THIS OWNER'S MANUAL CAREFULLY.**
- Do not exceed the boat manufacturer's power recommendation, and be sure the outboard motor is properly mounted.
- Never permit anyone to operate the outboard motor without proper instruction.
- Stop the engine immediately if anyone falls overboard.
- Do not run the motor while the boat is near anyone in the water.
- Exhaust contains poisonous carbon monoxide which can cause unconsciousness and may lead to death. Never run the outboard in a closed garage or confined area.
- Gasoline is extremely flammable and is explosive under certain conditions. Refuel in a well-ventilated area with the engine stopped.
- Do not smoke or allow flames or sparks where the engine is refueled or where gasoline is stored.
- Do not overfill the fuel tank. After refueling make sure that the fuel tank cap is closed properly and securely.
- Be careful not to spill any fuel while refueling. Spilled fuel or fuel vapor may ignite. If any fuel is spilled, make sure that the area is dry before starting the engine.
- Do not remove any guards, labels, shields, covers or safety devices; they are installed for your safety.

2. COMPONENT IDENTIFICATION

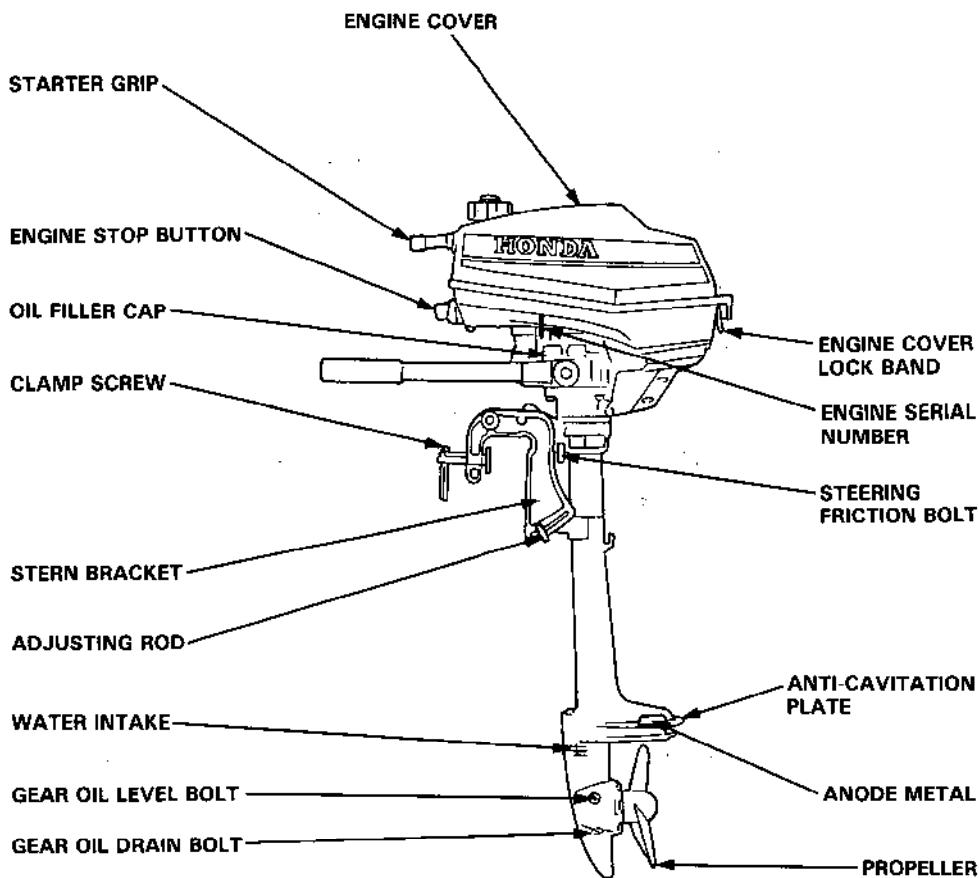

(BF2A S)

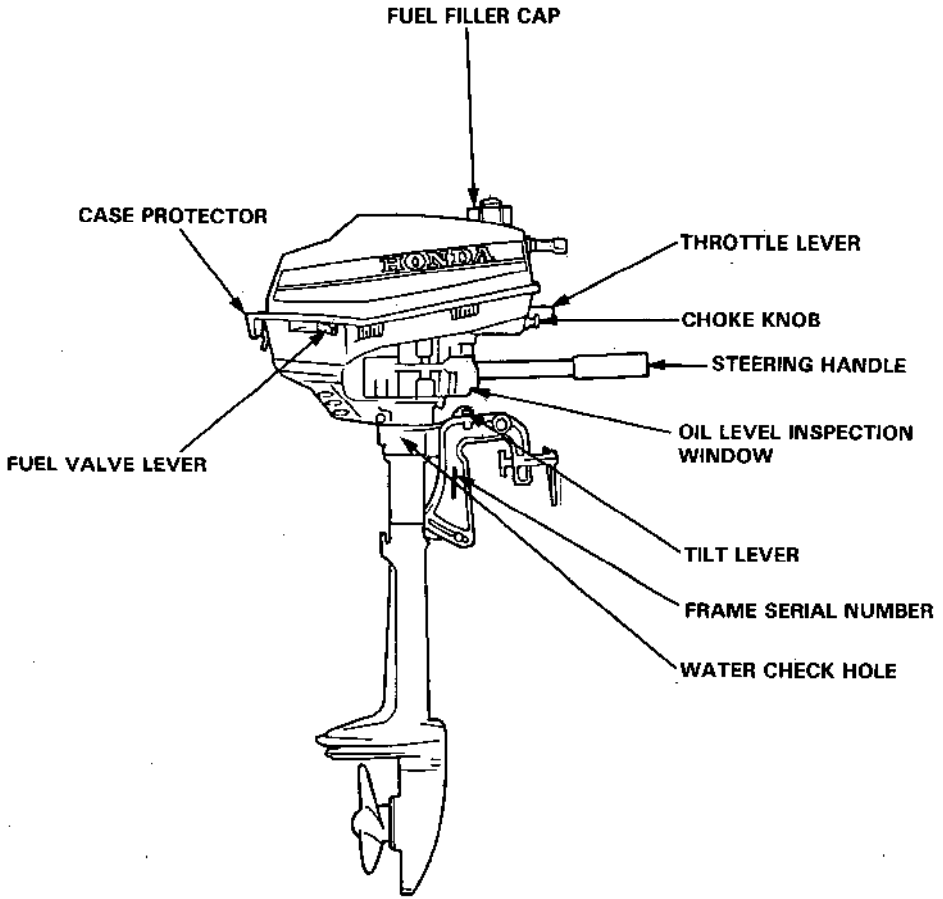

(BF2A S)

3. INSTALLATION

It is your responsibility to choose a boat suitable for the engine (2 horsepower).

Model	Transom length
S (Short)	420 mm (16.5 in)
L (Long)	570 mm (22.4 in)

▲WARNING Do not exceed the boat manufacturer's power recommendation. Damage and injury may result. Two shaft lengths are available for the BF2A, either long or short, to match the transom height of the boat.

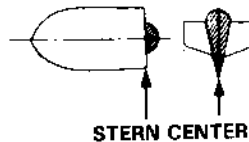

1. Installation Position

Install at the stern at the center line of the boat.

2. Installation Height

For proper propeller depth and engine cooling, the boat's transom height must match the motor's shaft length. The short shaft motor requires a transom height of about 15 in. The long shaft motor requires a transom height about 20 in. Once the boat is in the water and loaded, check proper motor depth by looking at the anti-cavitation plate: with the motor not running, the plate should be about 100 mm (4 in.) below the surface of the water.

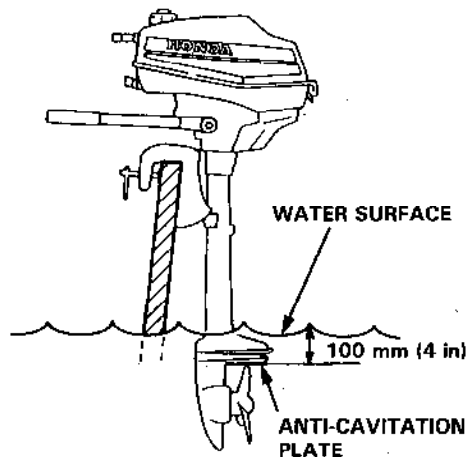

During operation, check to be sure the anti-cavitation plate remains under water at all times and that water flows from the water check hole. Excessive or imbalanced loading will affect the motor's water depth. Loading too far forward will raise the motor out of the water, reducing engine cooling. Loading too much or too far rearward will push the motor deeper, reducing performance.

CAUTION: Insufficient water supply (anti-cavitation plate out of the water) may cause overheating that will damage the outboard motor.

3. Motor Attachment

Attach the stern bracket to the transom and tighten the clamp screws.

CAUTION:

- While operating the boat, check the tightness of the clamp screws occasionally.
- Tie a rope through the hole in the stern bracket and secure the other end of the rope to the boat. This will prevent accidental loss of the motor.

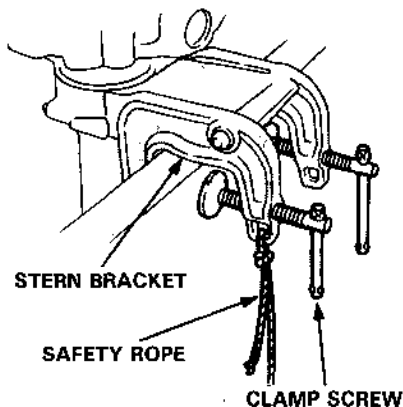

4. Motor Angle (Cruising)

Adjust the motor so the axis of the propeller is parallel with the water surface.

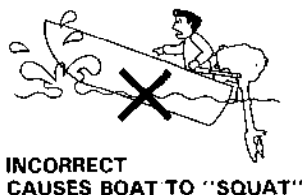
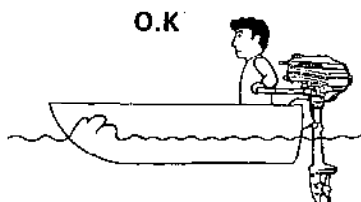

5. Motor Angle Adjustment

If the propeller axis is not parallel with the surface of the water, adjust the angle of the motor by relocating the adjusting bolt on the stern brackets. There are four adjustment positions.

1. Loosen the wing nut to free the adjusting bolt.
2. Adjust the angle of the motor, and tighten the wing nut. Be sure that the bolt head and wing nut are seated in one of the four recesses on the adjustment slot.

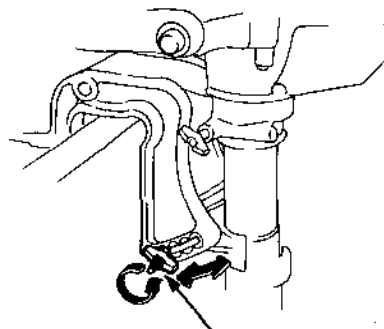

CAUTION: To prevent damage to the motor or boat, make sure the adjusting rod is locked.

4. PRE-OPERATION CHECKS

1. Engine Oil Level

CAUTION:

- Engine oil is a major factor affecting engine performance and service life. Nondetergent and low quality oils are not recommended, because they have inadequate lubricating properties.
- Running the engine with insufficient oil can cause serious engine damage.

Use Honda 4-stroke oil or an equivalent high detergent, premium quality motor oil certified to meet or exceed U.S. automobile manufacturers' requirements for Service Classification SF CC/CD or SG. Motor oils classified SF CC/CD or SG will show this designation on the container.

Select the appropriate viscosity for the average temperature in your area. SF CC/CD or SG 10W-30 is recommended for general, all-temperature use.

1. Position the outboard motor vertically, and check the oil level in the oil level inspection window.
2. If the oil level is down toward the lower level mark on the window, fill up to the 0.4 ℓ (0.42 U.S. qt.) mark on the dipstick.

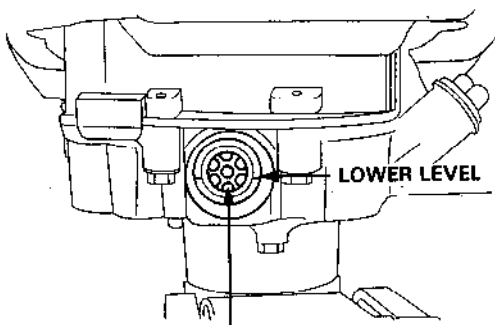
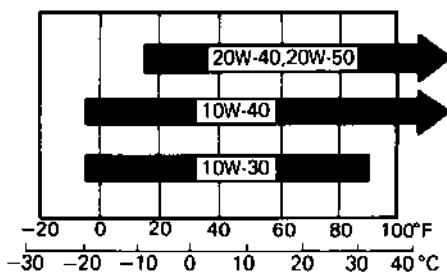

OIL LEVEL INSPECTION WINDOW

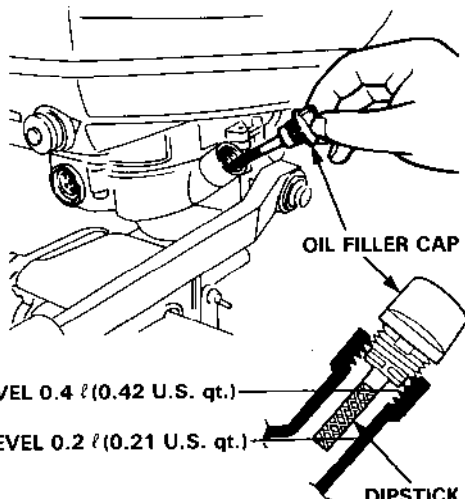

UPPER LEVEL 0.4 ℓ (0.42 U.S. qt.)

LOWER LEVEL 0.2 ℓ (0.21 U.S. qt.)

2. Fuel Level

Remove the filler cap and check the fuel level. Refill the tank if the fuel level is low.

NOTE: Open the vent knob before removing the fuel filler cap. When the vent knob is firmly closed, the cap will be difficult to remove.

Your engine is designed to use any gasoline that has a pump octane number ($\frac{R+M}{2}$) of 86 or higher, or that has a research octane number of 91 or higher. Gasoline pumps at service stations normally display the pump octane number.

We recommend that you use unleaded fuel because it produces fewer engine and spark plug deposits and extends the life of exhaust system components.

Never use stale or contaminated gasoline or an oil/gasoline mixture. Avoid getting dirt, dust or water in the fuel tank. Use of a lower octane gasoline can cause persistent "pinging" or heavy "spark knock" (a metallic rapping noise) which, if severe, can lead to engine damage.

CAUTION: If "spark knock" or "pinging" occurs at a steady engine speed under normal load, change brands of gasoline. If spark knock or pinging persists, consult your authorized Honda dealer. Failure to do so is considered misuse, and damage caused by misuse is not covered by Honda's Limited Warranty.

Occasionally you may experience light spark knock while operating under heavy loads. This is no cause for concern, it simply means your engine is operating efficiently.

Fuel tank capacity: 1.0 ℓ (0.26 U.S. gal.)

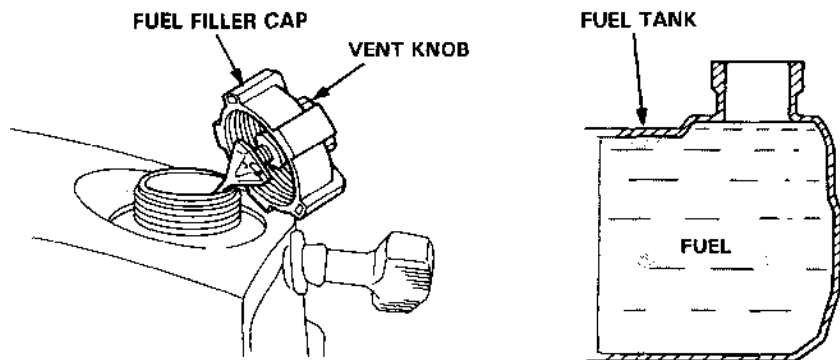

After refueling, be sure to tighten the fuel tank cap firmly.

⚠ WARNING Gasoline is extremely flammable and is explosive under certain conditions.

▲ WARNING

- Refuel in a well-ventilated area with the engine stopped. Do not smoke or allow flames or sparks in the area where the engine is refueled or where gasoline is stored.
- Do not overfill the tank (there should be no fuel in the filler neck). After refueling, make sure the tank cap is closed properly and securely.
- Be careful not to spill fuel when refueling. Spilled fuel or fuel vapor may ignite. If any fuel is spilled, make sure the area is dry before starting the engine.
- Avoid repeated or prolonged contact with skin or breathing of vapor. **KEEP OUT OF REACH OF CHILDREN.**

GASOLINES CONTAINING ALCOHOL

If you decide to use a gasoline containing alcohol (gasohol), be sure its octane rating is at least as high as that recommended by Honda. There are two types of "gasohol": one containing ethanol, and the other containing methanol. Do not use gasohol that contains more than 10% ethanol. Do not use gasoline containing methanol (methyl or wood alcohol) that does not also contain cosolvents and corrosion inhibitors for methanol. Never use gasoline containing more than 5% methanol, even if it has cosolvents and corrosion inhibitors.

NOTE:

- Fuel system damage or engine performance problems resulting from the use of fuels that contain alcohol is not covered under the warranty. Honda cannot endorse the use of fuels containing methanol since evidence of their suitability is as yet incomplete.
- Before buying fuel from an unfamiliar station, try to find out if the fuel contains alcohol; if it does, confirm the type and percentage of alcohol used. If you notice any undesirable operating symptoms while using a gasoline that contains alcohol, or one that you think contains alcohol, switch to a gasoline that you know does not contain alcohol.

3. Other Checks

Check the following items.

- ① Propeller, shear pin and cotter pin. Check for looseness or damage.
- ② Steering handle. Check for impaired operation.
- ③ Stern bracket. Check for damage.
- ④ Tool kit. Check for missing spare parts and tools (page 27).
- ⑤ Anode metal. Check for looseness, damage or excessive corrosion.

The anode metal helps to protect the outboard motor from corrosion damage; it must be exposed directly to the water whenever the motor is in use. Replace the anode metal when it has been reduced to approximately one half of its original size.

CAUTION: The possibility of corrosion damage increased if the anode metal is painted over or allowed to deteriorate.

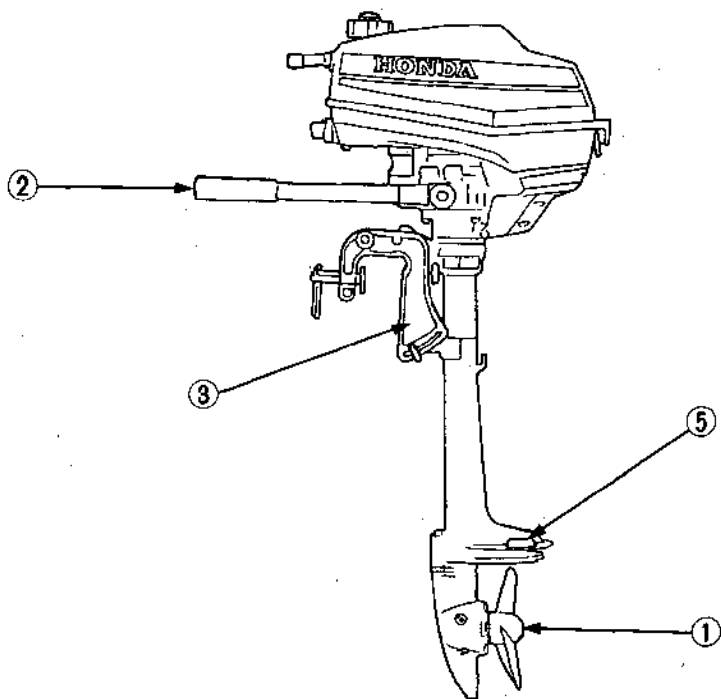

5. STARTING THE ENGINE

CAUTION: To prevent damage to the outboard from overheating, never run the engine with the propeller out of the water.

1. Open the fuel cap vent knob 2 to 3 turns.

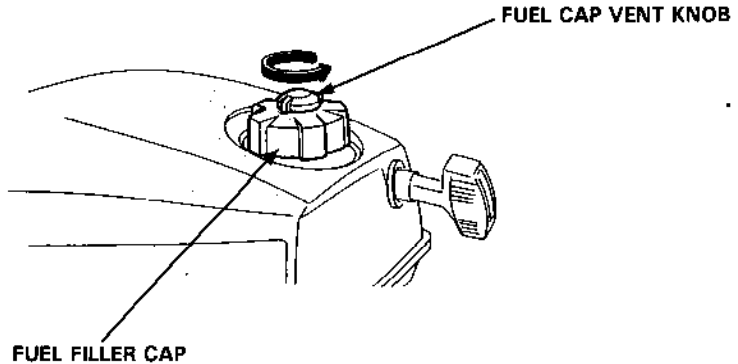

2. Turn the fuel valve lever ON.

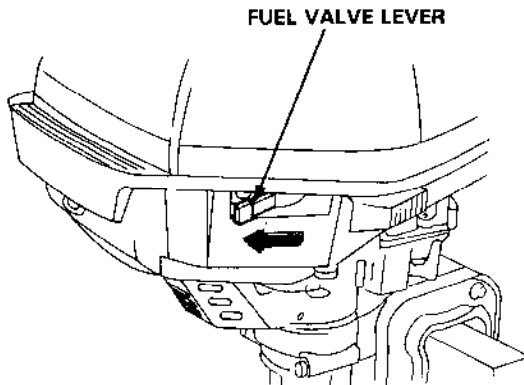

3. Move the throttle lever to the START position.

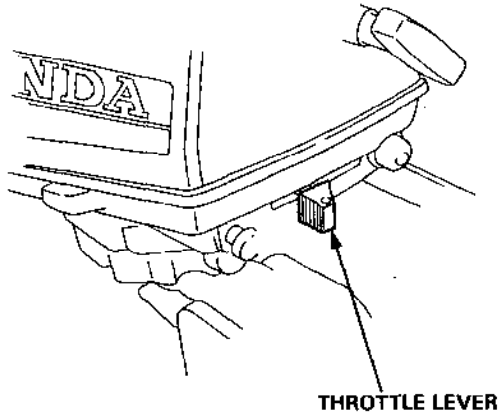

CAUTION: Do not start the engine with the throttle lever in the FAST position, or the boat will move suddenly when the engine starts.

4. In temperatures below 20°C (68° F) use the choke knob.

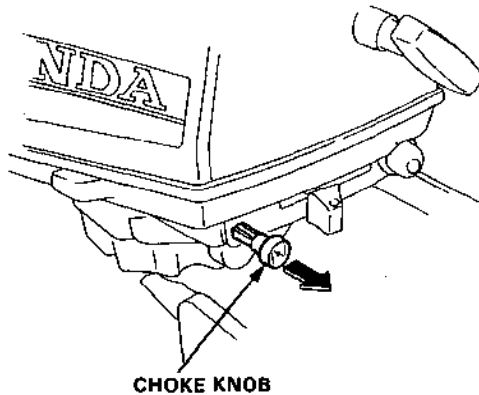

5. Pull the starter rope slowly until resistance is felt, then pull briskly.

CAUTION: Do not allow the starter grip to snap back against the housing; return it gently by hand to prevent damage to the starter.

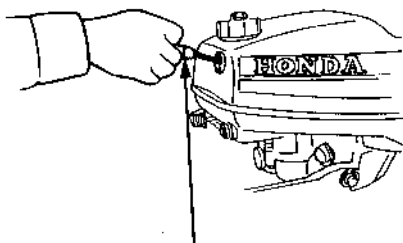

STARTER GRIP

6. After starting, be sure water is flowing out of the water check hole.

CAUTION: If water does not flow out, or if steam comes out, stop the engine. Check to see if the screen in the cooling water inlet is obstructed. Do not operate the engine until the problem has been corrected.

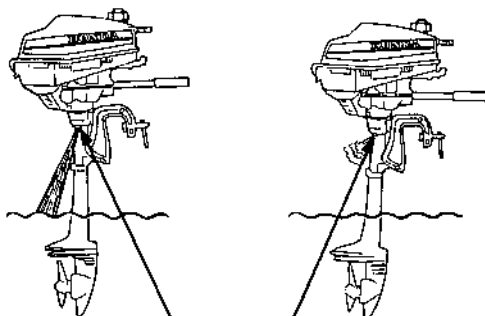

NORMAL
FLOW

INTAKE
OBSTRUCTED

WATER CHECK HOLE

7. If the choke was used, push it in gradually as the engine warms up.

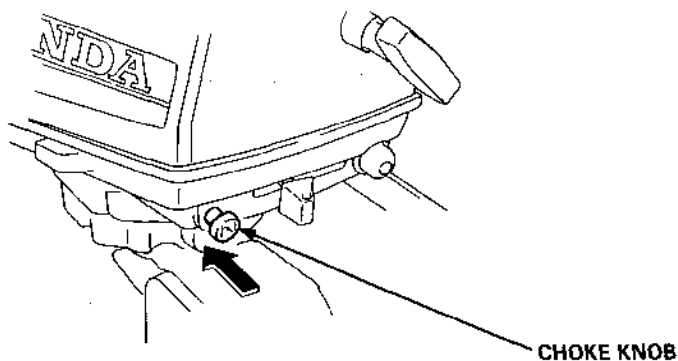

▲ WARNING

- Exhaust contains poisonous carbon monoxide gas; exposure can cause loss of consciousness and may lead to death. Never run the engine in an enclosed area. Be sure to provide adequate ventilation.
- Be careful not to spill any fuel when refueling. Spilled fuel or fuel vapor may ignite. If any fuel is spilled make sure the area is dry before starting the engine.

Emergency Starting

If the recoil starter is not working properly, the engine can be started with the spare starter rope in the tool kit.

1. Remove the engine cover.
2. Remove the recoil starter by removing the three 6 mm nuts.
3. Wind the spare rope clockwise around the pulley, and then pull it to start the engine.

CAUTION: Keep clear of moving parts.

4. Reinstall the engine cover.

CAUTION: Do not operate without the engine cover. Exposed moving parts could cause injury and water may damage the engine.

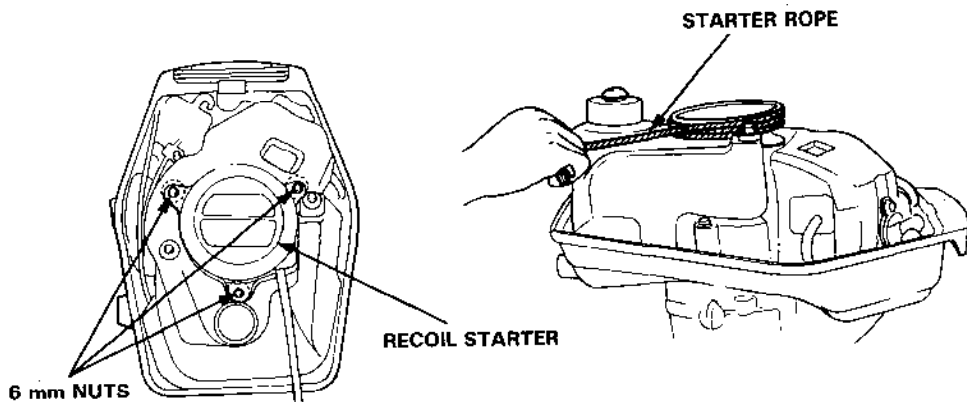
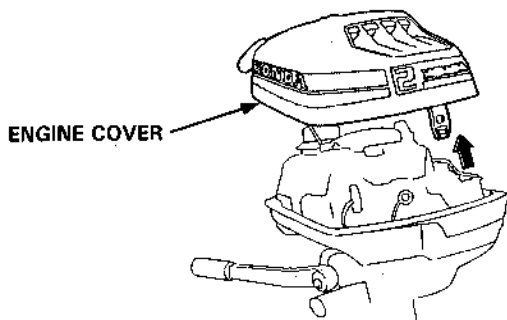

6. OPERATION

1. Cruising

CAUTION: For the first 10 hours of operation, run the outboard motor at low speed, and avoid abrupt operation of the throttle.

Turn the throttle lever toward FAST to increase speed. For normal cruising, open the throttle about 3/4.

NOTE: For best performance, passengers and equipment should be distributed evenly to balance the boat.

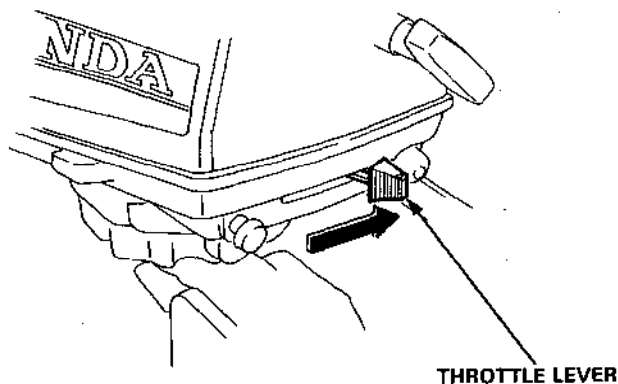

2. Steering

To turn to the right, swing the steering handle to the left. To turn to the left, swing the handle to the right.

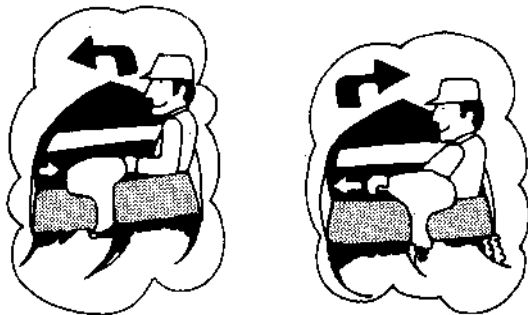

For smooth steering, adjust the steering friction bolt so that a slight drag is felt when turning.

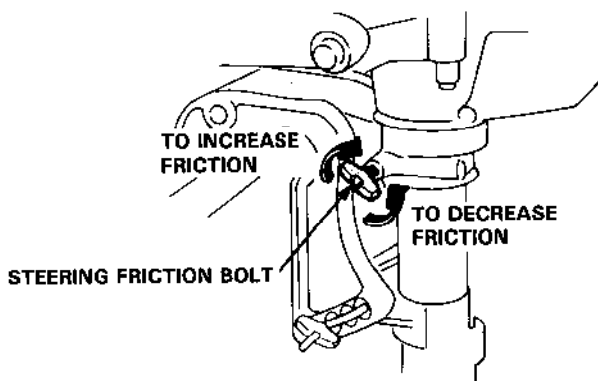

3. Reverse

1. Move the throttle lever to the SLOW position.

CAUTION: Before rotating the motor (from either forward to reverse or from reverse to forward) reduce the engine speed to **SLOW**, or the boat could capsize.

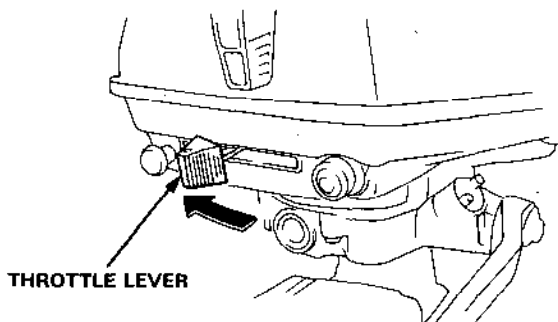

2. To reverse direction, turn the motor 180°, and then pivot the steering handle as shown.

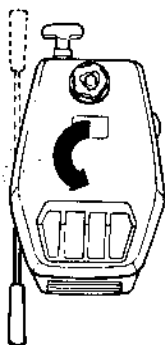

CAUTION: When operating in reverse, proceed with caution to avoid hitting any under water obstruction with the propeller.

4. Tilting the Motor

Tilt the motor to prevent the propeller and gear case from hitting bottom when the boat is beached or stopped in shallow water.

1. Stop the engine and turn the fuel valve lever off.
2. Close the fuel cap vent knob.
3. With the motor in the forward position, raise the motor using the carrying handle. The spring-loaded tilt lever will automatically move into position and hold the motor when it reaches approximately 75°.
4. Adjust the steering friction bolt to keep the motor from moving.

CAUTION: If the motor is tilted in the reverse position, crankcase oil will enter the cylinder and may cause difficult starting or may prevent the engine from being cranked. If this occurs, refer to the TROUBLE-SHOOTING section. page 36.

5. To return the motor to the normal RUN position, hold the motor by the carrying handle and pull the tilt lever toward you, then lower the motor slowly.

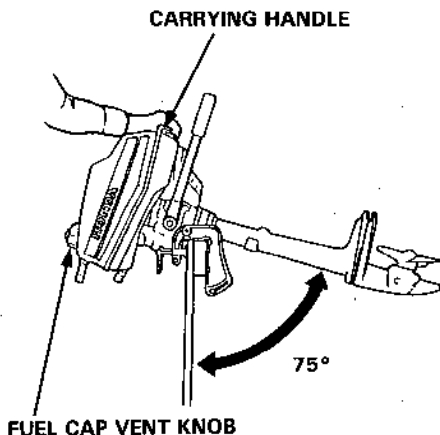
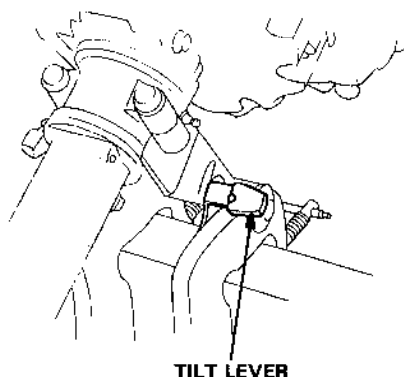

CAUTION: Do not transport the motor in the tilted position; it may drop suddenly causing damage to the boat or the motor.

CAUTION: To avoid damaging the motor, use the utmost care when mooring the boat, especially when its motor is tilted up. Don't allow the motor to strike against the pier or other boats.

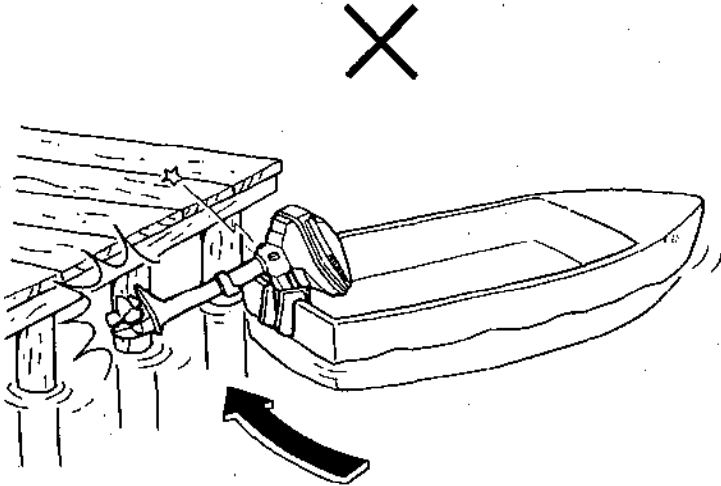

CAUTION: To avoid damaging the motor, never use it as a handle for lifting or moving the boat.

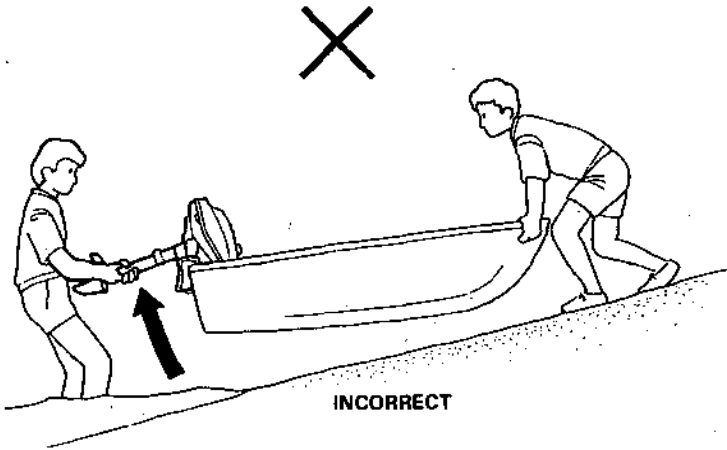

- **High altitude operation**

At high altitude, the standard carburetor air-fuel mixture will be excessively rich. Performance will decrease, and fuel consumption will increase. High altitude performance can be improved by installing a smaller diameter main fuel jet in the carburetor and readjusting the pilot screw. If you always operate the outboard motor at altitudes higher than 6,000 feet above sea level, have your authorized Honda Outboard Motor dealer perform these carburetor modifications.

Even with suitable carburetor jetting, engine horsepower will decrease approximately 3.5% for each 1,000 foot increase in altitude. The effect of altitude on horsepower will be greater than this if no carburetor modification is made.

CAUTION: Operation of the outboard motor at an altitude lower than the carburetor is jetted for may result in reduced performance, overheating, and serious engine damage caused by an excessively lean air/fuel mixture.

7. STOPPING THE ENGINE

1. Move the throttle lever all the way to the left.

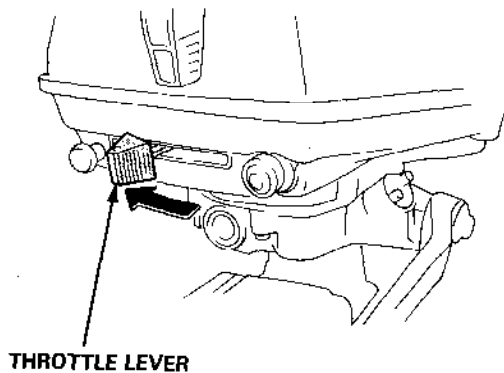

2. Push the stop button until the engine stops running.

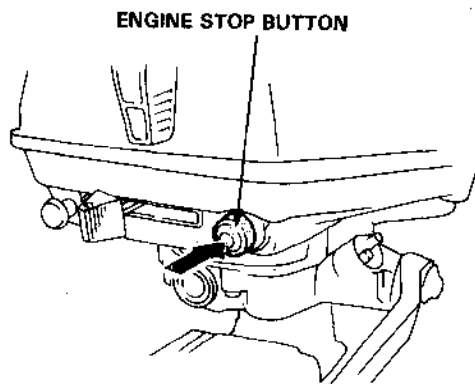

3. Turn the fuel valve lever OFF.

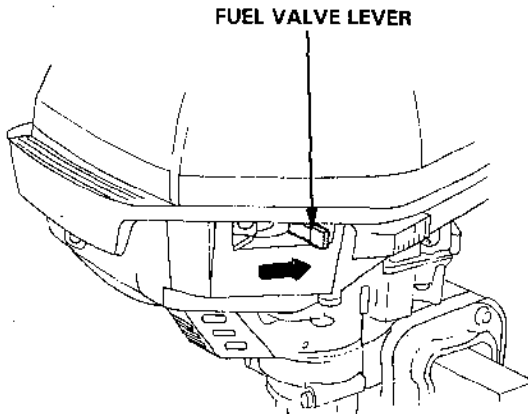

4. Close the fuel cap vent knob.

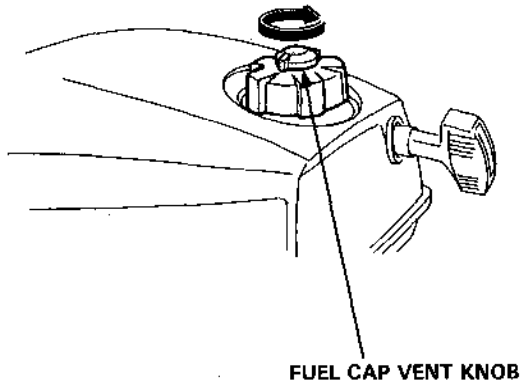

8. MAINTENANCE

Periodic maintenance and adjustment is necessary to keep the engine in good operating condition. Perform the service and inspection scheduled in the following table.

▲ WARNING Shut off the engine before performing any maintenance. If the engine must be run, make sure the area is well ventilated. Never run the engine in an enclosed or confined area. Exhaust contains poisonous carbon monoxide gas; exposure can cause loss of consciousness and may lead to death.

CAUTION: Use only genuine HONDA parts or their equivalent. The use of replacement parts which are not of equivalent quality may damage the engine.

Maintenance Schedule

REGULAR SERVICE PERIOD		EACH USE	FIRST MONTH OR 20 HRS (3)	EVERY 6 MONTHS OR 100 HRS (3)	EVERY YEAR OR 200 HRS (3)
ITEM	Performed at every indicated month or operating hour intervals, whichever comes first.				
Engine oil	Check level	○			
	Change		○	○	
Gear case oil	Check level	○			
	Change		○		○
	Check for water contamination			○	
Starter rope	Check			○	
Carburetor linkage	Check		○(2)	○(2)	
Valve clearance	Check-Readjust		○(2)		○(2)
Spark plug	Clean-Readjust			○	
Shear pin	Check			○	
Lubrication	Grease			○(1)	
Fuel tank and filter	Clean				○
Combustion chamber and valves	Clean-Relap	Every 300 hours (2)			
Fuel line	Check (Replace if necessary)	Every 3 years (2)			

NOTE: (1) Lubricate more frequently when used in salt water.

(2) These items should be serviced by an authorized Honda outboard dealer, unless the owner has the proper tools and is mechanically proficient. See the Honda Shop Manual.

(3) For professional commercial use, log hours of operation to determine proper maintenance intervals.

1. Tool kit and spare parts

The following tools and spare parts are supplied with the outboard motor for maintenance, adjustment, and emergency repairs.

TOOL KIT

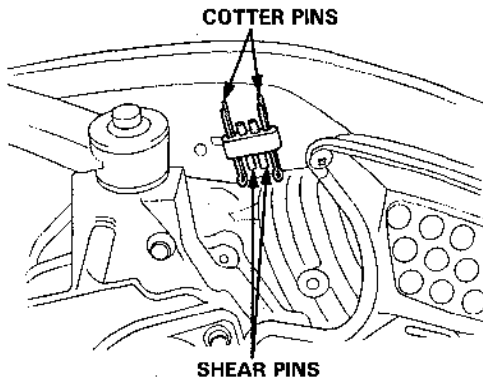
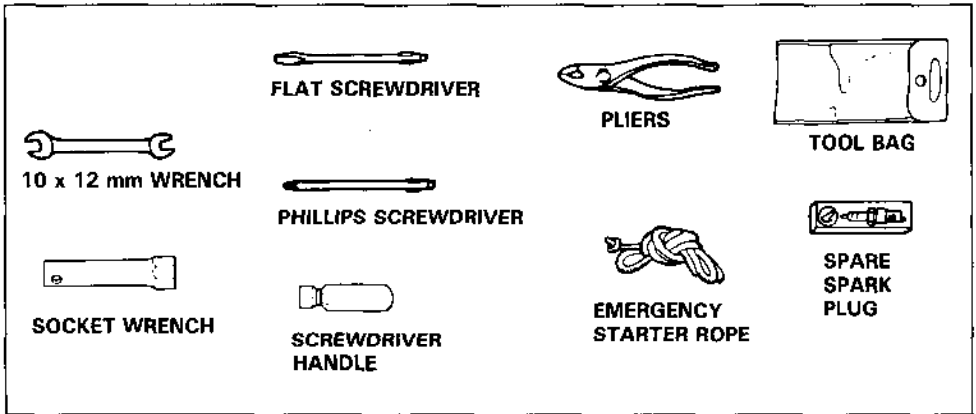

2. Engine Oil Change

Drain the oil while the engine is still warm to assure rapid and complete draining.

1. Turn the fuel valve lever OFF, and close the fuel cap vent knob.
2. Remove the oil filler cap, and turn the motor on its side to drain the oil.
3. Stand the engine in an upright position, and fill the crankcase with the recommended oil (see page 9). Check the oil level with the dipstick resting on the filler opening (do not screw in). Fill to the upper level mark on the dipstick.

Oil capacity: 0.4ℓ (0.42 U.S. qt.)

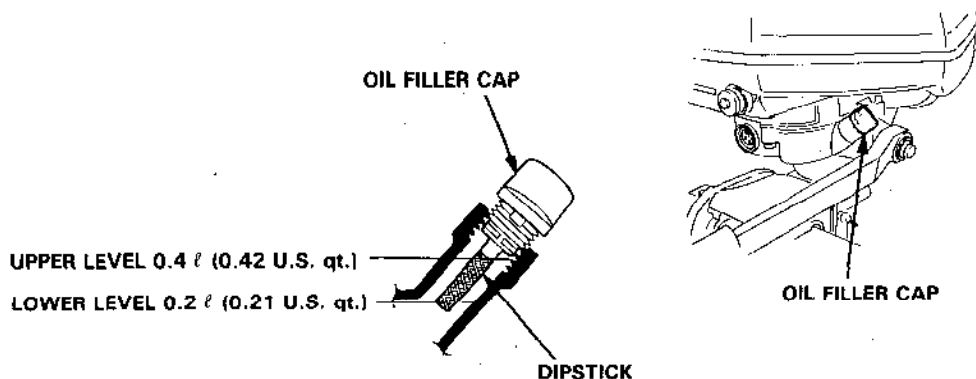

CAUTION: Used motor oil may cause skin cancer if repeatedly left in contact with the skin for prolonged periods. Although this is unlikely unless you handle used oil on a daily basis, it is still advisable to thoroughly wash your hands with soap and water as soon as possible after handling used oil.

NOTE: Please dispose of used motor oil in a manner that is compatible with the environment. We suggest you take it in a sealed container to your local service station for reclamation. Do not throw it in the trash or pour it on the ground.

3. Gear Oil Check/Change

Oil Level Check

Check the oil level when the engine is in the vertical position. Remove the level bolt and see if oil flows out. If no oil comes out, fill through the drain bolt hole until the oil starts to flow out through the level bolt hole. If there is water in the oil, the water will flow out first when the drain bolt is removed, or the oil will be a milky color.

Oil Change

Remove the level bolt and drain bolt to drain the oil. Inject oil through the drain bolt hole until it starts flowing out through the level bolt hole. Reinstall and tighten the level bolt and drain bolt securely.

CAUTION: If water is detected in the oil, the unit should be inspected by an authorized Honda outboard motor dealer.

Recommended Oil: API standard (GL-4 or GL-5)
SAE 90 outboard motor gear oil

Oil capacity: 0.05^l (0.053 U.S. qt.)

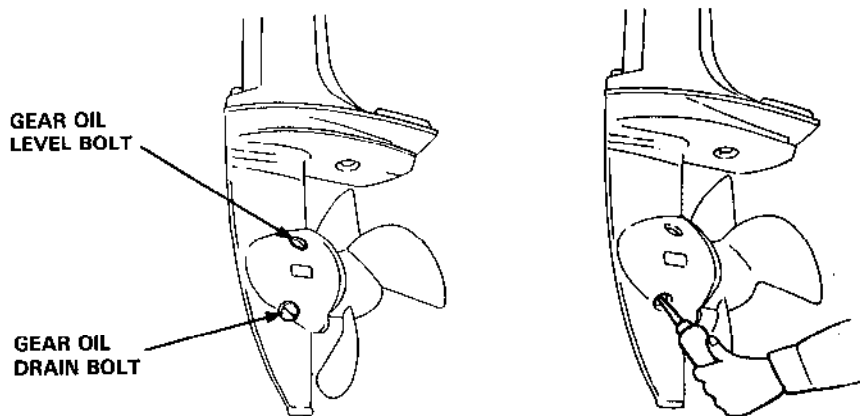

4. Starter Rope Check

Check the starter rope every 6 months or after every 100 hours of outboard motor operation. Replace the rope if it is frayed.

5. Spark Plug Service

Recommended spark plug: BMR-4A (NGK)

1. Remove the engine cover.
2. Remove the spark plug cap.
3. Use the wrench supplied in the tool kit to remove the spark plug.
4. Visually inspect the spark plug. Discard it if the insulator is cracked or chipped.
5. Measure the plug gap with a feeler gauge.
The gap should be 0.7–0.8 mm (0.028–0.031 in). Correct as necessary by bending the side electrode.
6. Check that the spark plug washer is in good condition, and thread the spark plug in by hand to prevent cross-threading.
7. After the spark plug is seated, tighten with socket wrench to compress the washer.

NOTE: If installing a new spark plug, tighten 1/2 turn after the spark plug seats to compress the washer. If reinstalling a used spark plug, tighten 1/8–1/4 turn after the spark plug seats to compress the washer.

8. Reinstall the engine cover.

CAUTION:

- The spark plug must be securely tightened. An improperly tightened plug can become very hot and may cause engine damage.
- Use only the recommended spark plug or equivalent. Spark plugs which have an improper heat range may cause engine damage.

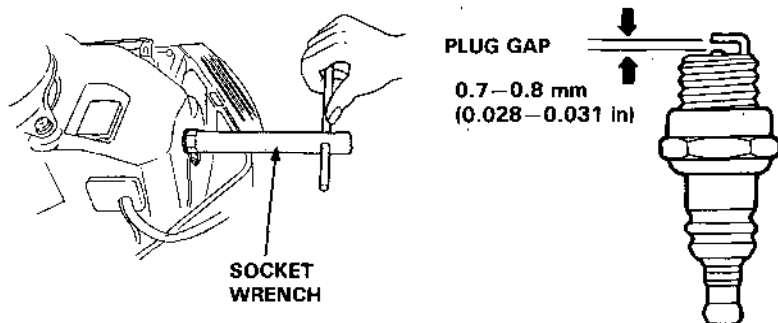

6. Cleaning and Flushing

After each use in salt water or dirty water, thoroughly clean and flush the outboard motor.

1. Wash the outside of the outboard motor with clean, fresh water.
2. Remove the propeller.
3. Stand the motor in a suitable container of water. The water level must be at least 4 inches above the anti-cavitation plate.
4. Start the engine and run it slowly for at least 5 minutes.

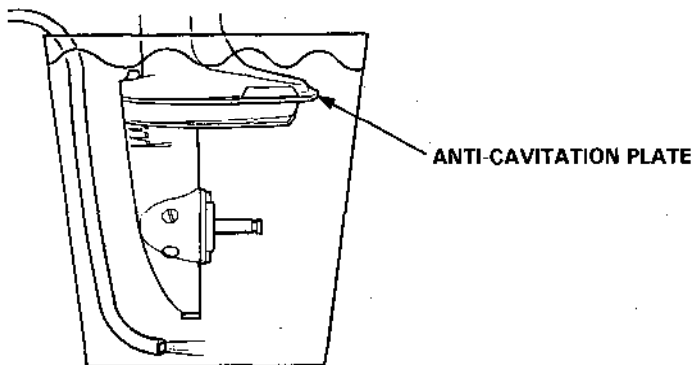

▲ WARNING

- For safety, the propeller must be removed.
- Be sure the outboard motor is securely mounted, and do not leave it unattended while running.
- Keep children and pets away from the area, and stay clear of moving parts during this procedure.

CAUTION: Running the engine without water can cause serious engine damage due to overheating. Be sure that water flows from the water check hole while the engine is running. If not, stop the engine and determine the cause of the problem.

7. Lubrication

Wipe the outside of the engine with a cloth dipped in clean oil. Apply marine anti-corrosion grease to the following areas:

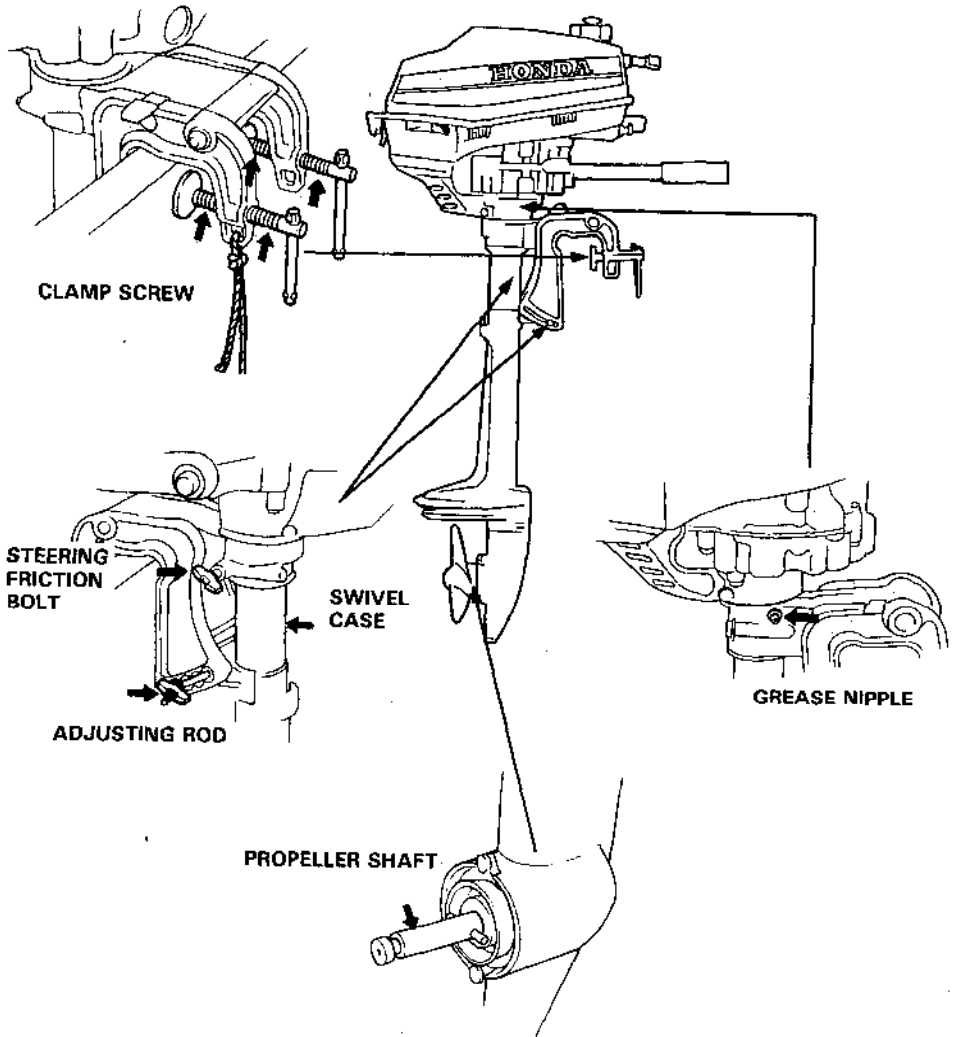

8. Shear Pin Change

A shear pin is used to protect the propeller and drive mechanism from damage when the propeller strikes an obstruction.

1. Remove the cotter pin and the propeller.
2. Remove the broken shear pin and replace it with a new one.
3. Install the propeller.
4. Install a new cotter pin, and spread the ends as shown in the illustration.

CAUTION: When replacing the shear pin, be careful not to drop the propeller into the water.

Precautions concerning the propeller

The propeller rotates at high speed when the boat is moving. Before setting off, therefore, check the propeller blades for damage or deformation, and if there are any abnormalities replace the propeller. Carry a spare propeller in case of an unforeseen accident on the water.

If a spare propeller is not available and an accident does occur, return to shore carefully while running the engine at low speed.

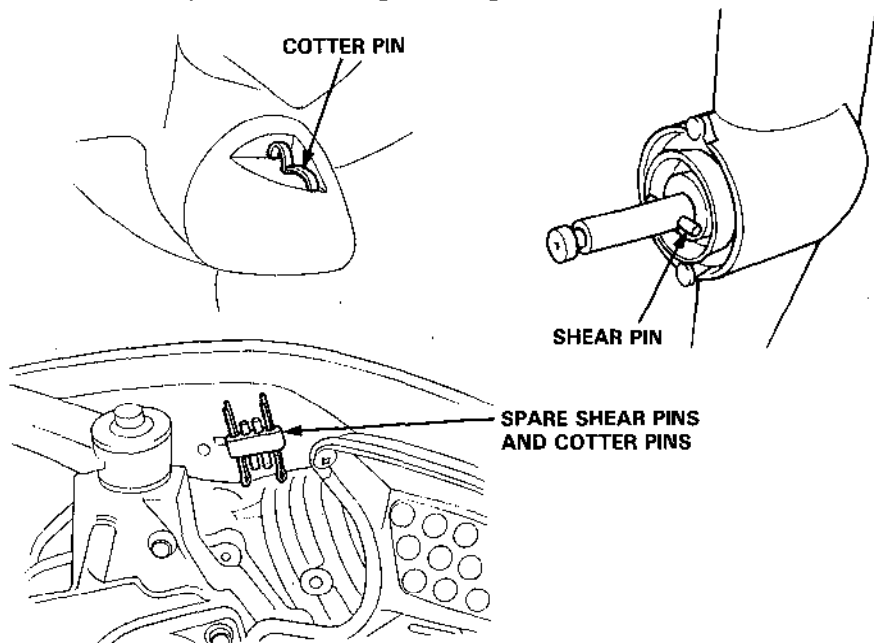

9. Servicing a Submerged Motor

A submerged motor must be serviced immediately after it is recovered from the water in order to minimize corrosion.

If there is a Honda outboard motor dealership nearby, take the motor immediately to the dealer. If you are far from a dealership, proceed as follows:

1. Remove the engine cover, and rinse the motor with fresh water to remove salt water, sand, mud, etc.
2. Drain the fuel tank into a suitable container.
3. Loosen the carburetor drain screw (page 35), drain the contents of the carburetor into a suitable container, then retighten the drain screw.
4. Change the engine oil (page 28). If there was water in the engine crankcase, or the used engine oil showed signs of water contamination, then a second engine oil change should be performed after running the engine for 1/2 hour.
5. Remove the spark plug. While pressing the engine stop button, pull the recoil starter several times to completely expel water from the cylinder.

CAUTION:

- When cranking the engine with an open ignition circuit (spark plug removed from the ignition circuit), keep the engine stop button depressed to prevent electrical damage to the ignition system.
 - If the motor was running when it submerged, there may be mechanical damage, such as a bent connecting rod. If the engine binds when cranked, do not attempt to run the motor until it has been repaired.
6. Pour a teaspoon of engine oil into the spark plug hole, then pull the recoil starter several times to lubricate the inside of the cylinder. Reinstall the spark plug.
 7. Attempt to start the engine. If the engine fails to start, remove the spark plug, clean and dry the electrode, then reinstall the spark plug and attempt to start the engine again. If the engine starts, and no mechanical damage is evident, continue to run the engine for 1/2 hour or longer (be sure the water level is at least 4 inches above the anti-cavitation plate).
 8. As soon as possible, take the motor to a Honda outboard motor dealer for inspection and service.

9. TRANSPORTING/STORAGE

1. Drain the water from the extension case.

While depressing the engine stop button to prevent starting, pull the starter rope several times to expel the water from the extension case.

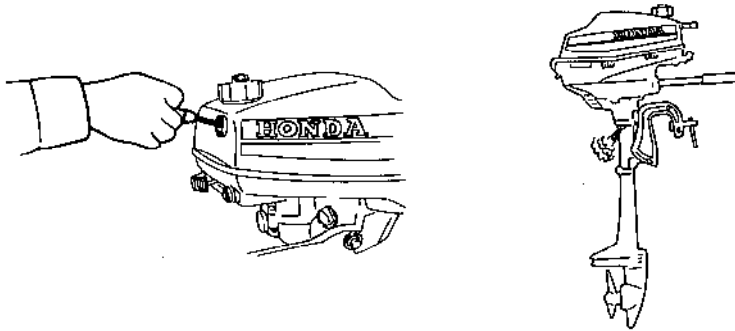

CAUTION:

- Do not rest the motor on its side until the water has been expelled from the extension case, otherwise water will seep into the exhaust system.
- In cold weather, the water must be expelled from the extension case to prevent ice from forming in the water pump and water tube.

2. Drain the fuel

1. Turn the fuel valve lever off.
2. Remove the fuel filler cap and drain the gasoline from the fuel tank into a suitable container.
3. Turn the fuel valve lever on, loosen the carburetor drain screw, and drain the gasoline into a suitable container.
4. After draining, retighten the drain screw.
5. Make sure the fuel cap vent knob is turned to OFF.

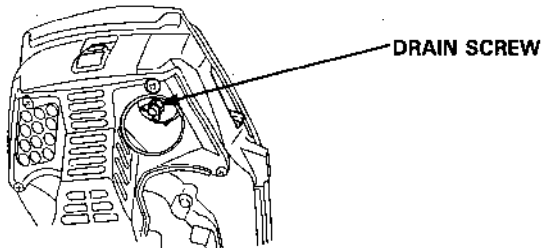

▲ WARNING

- Be careful not to spill fuel. Spilled fuel or fuel vapor may ignite. If any fuel is spilled, make sure the area is dry before storing or transporting the motor.
- Do not smoke or allow flames or sparks where fuel is drained or stored.

3. To carry, hold the motor by the carrying handle.
Do not carry by the engine cover.

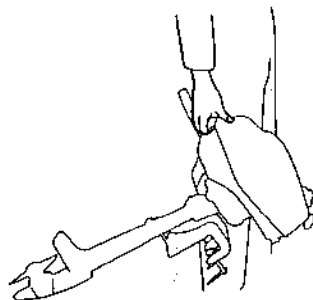

4. Transport and store the motor either vertically or horizontally, as shown here.
Vertical transport or storage: Attach the stern bracket to a stand.

CAUTION:

- Any other transport or storage position may cause damage or oil leakage.
- If the motor is tilted in the reverse position, crankcase oil will enter the cylinder and may cause difficult starting or may prevent the engine from being cranked. If this occurs refer to the **TROUBLESHOOTING** section, page 37.

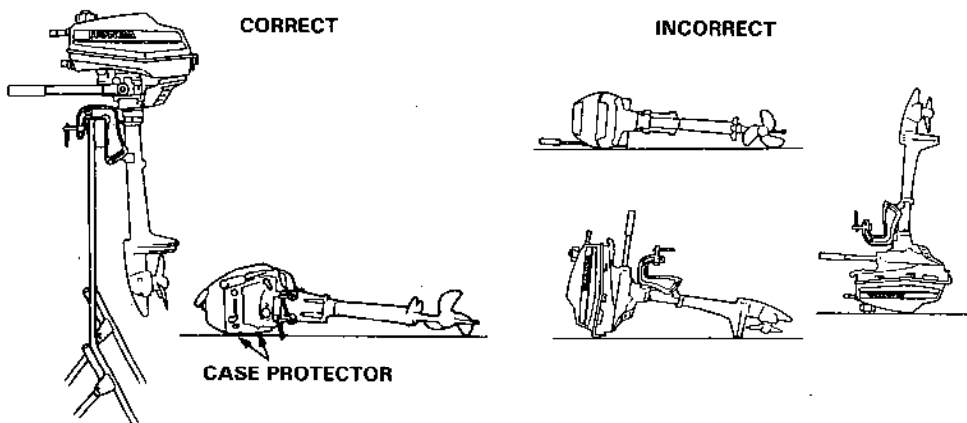

5. Store the outboard motor in a clean, dry area.

NOTE: Before storing, clean, flush and lubricate the outboard motor as described on pages 31 and 32.

Engine Will Not Start:

1. Is there fuel in the fuel tank?
2. Is the fuel cap vent knob turned to ON?
3. Is fuel reaching the carburetor?

Loosen the carburetor drain screw to see if there is fuel in the carburetor float bowl.

⚠ WARNING If any fuel is spilled, make sure the area is dry before testing the spark plug or starting the engine. Spilled fuel or fuel vapor may ignite.

4. Is the spark plug firing?
 - a. Remove and inspect the spark plug. Clean and dry the plug, and check the electrode gap (page 30).
 - b. Install the spark plug in its cap, and ground the side electrode to any engine ground.
 - c. Pull the recoil starter briskly, and see if the plug sparks.
 - d. If the spark plug is OK, reinstall it, and try to start the engine.

If the plug does not spark, try the same test with a new spark plug. If there is still no spark, take the outboard motor to an authorized Honda dealer for repair.

Extension Case Overheats:

1. Is the water intake clogged?

11. SPECIFICATIONS

Model	BF2A
Description Code	BAES (S Model) BAEL (L Model)
Output	2.0 horse power (Maximum)
Full throttle range	4,000–5,000 rpm
Engine type	4-stroke side valve one cylinder
Displacement	76 cc (4.7 cu in)
Valve tappet clearance	0.08–0.16 mm (0.003–0.006 in)
Spark plug gap	0.7–0.8 mm (0.028–0.031 in)
Starter system	Recoil starter
Ignition system	Transisterized magneto
Lubrication system	Oil slinger system
Specified oil	Engine: API standard (SE or SF) SAE 10W-30 Gear case: API standard (GL-4/5) SAE 90 outboard motor gear oil
Oil capacity	Engine: 0.4 ℓ (0.42 US qt) Gear case: 0.05 ℓ (0.053 US qt)
Cooling system	Engine: Forced air cooling Exhaust system: Water cooling
Exhaust system	Underwater exhaust
Spark plug	BMR-4A(NGK)
Fuel	Automotive gasoline (91 research octane, 86 pump octane)
Tank capacity	1.0 ℓ (0.26 US gal)
Steering equipment	Bar handle
Tilt angle	75°
Angle of rotation	360°
Dimensions, Length X Height X Width	S Model 410 x 930 x 275 mm (16.1 x 36.6 x 10.8 in) L Model 410 x 1,080 x 275 mm (16.1 x 42.5 x 10.8 in)
Height from stern bracket to anti-cavitation plate	S Model 420 mm (16.5 in) L Model 570 mm (22.4 in)
Standard Propeller (No. of blades-diameter X pitch)	3-184 x 120 mm (7-1/4 X 4-3/4 in)
Dry weight	S Model 12.5 kg (27.56 lb) L Model 13.0 kg (28.66 lb)

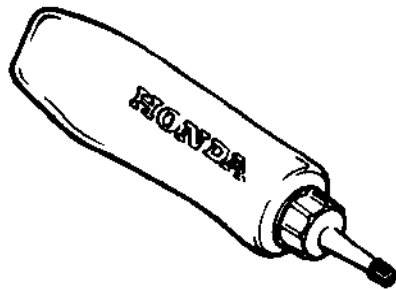

GEAR OIL

13. WARRANTY SERVICE

Owner Satisfaction

Your satisfaction and goodwill are important to your dealer and to us. All Honda warranty details are explained in the Distributor's Limited Warranty. Normally, any problems concerning the product will be handled by your dealer's service department. If you have a warranty problem that has not been handled to your satisfaction, we suggest you take the following action:

- Discuss your problem with a member of dealership management. Often complaints can be quickly resolved at that level. If the problem has already been reviewed with the Service Manager, contact the owner of the dealership or the General Manager.
- If your problem still has not been resolved to your satisfaction, contact the Power Equipment Customer Relations Department of American Honda Motor Co., Inc.

American Honda Motor Co., Inc.
Power Equipment Customer Relations Department
P.O. Box 50
Gardena, California 90247-0805
Telephone: (213) 604-2400

We will need the following information in order to assist you:

- Your name, address, and telephone number
- Product model and serial number
- Date of purchase
- Dealer name and address
- Nature of the problem

After reviewing all the facts involved, you will be advised of what action can be taken. Please bear in mind that your problem will likely be resolved at the dealership, using the dealer's facilities, equipment, and personnel, so it is very important that your initial contact be with the dealer.

Your purchase of a Honda product is greatly appreciated by both your dealer and American Honda Motor Co., Inc. We want to assist you in every way possible to assure your complete satisfaction with your purchase.

Current customer service contact information:

Your owner's manual was written to cover most of the questions you might ask about your Honda. Any questions not answered in the owner's manual can be answered by your Honda dealer. If your dealer doesn't have an immediate answer, they should be able to get it for you.

If you have a difference of opinion with your dealer, please remember that each dealership is independently owned and operated. That's why it's important to work to resolve any differences at the dealership level. If the service personnel are unable to assist you, please discuss your concerns with the dealer management such as the Service Manager or the dealership's owner.

If you need to contact American Honda regarding your experiences with your Honda product or with your dealer, please send your comments to the following address:

American Honda Motor Co., Inc.
Marine Division
Customer Relations Office
4900 Marconi Drive
Alpharetta, GA 30005-8847

Or telephone: (770) 497-6400 M-F, 8:30 am - 7:00 pm EST

When you write or call, please provide the following information:

- Your name, address and telephone number (complete with area code)
- Model and complete serial number
- Date of purchase
- Name and location of the selling dealer
- Name and location of the servicing dealer (if different)
- A detailed description of your concerns

HONDA
HONDA MOTOR CO., LTD. TOKYO, JAPAN

31ZV0810
00X31-ZV0-B100

④ ③ ② ① 100089C3K
PRINTED IN JAPAN