

HONDA
MARINE

Owner's Manual
Outboard Motor
BF8A

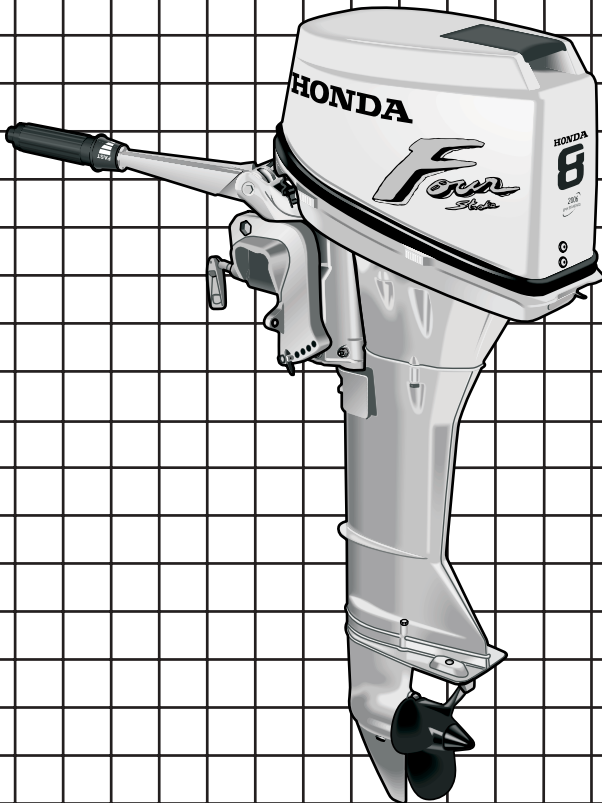

2000



WARNING:



The engine exhaust from this product contains chemicals known to the State of California to cause cancer, birth defects or other reproductive harm.

Keep this owner's manual handy, so you can refer to it at any time. This owner's manual is considered a permanent part of the outboard motor and should remain with the outboard motor if resold.

The information and specifications included in this publication were in effect at the time of approval for printing. Honda Motor Co., Ltd. reserves the right, however, to discontinue or change specifications or design at any time without notice and without incurring any obligation whatever. No part of this publication may be reproduced without written permission.

INTRODUCTION

Congratulations on your selection of a Honda outboard motor. We are certain you will be pleased with your purchase of one of the finest outboard motors on the market.

We want to help you get the best results from your new outboard motor and to operate it safely. This manual contains the information on how to do that; please read it carefully.

As you read this manual, you will find information preceded by a **NOTICE** symbol. That information is intended to help you avoid damage to your outboard motor, other property, or the environment.

We suggest you read the warranty policy to fully understand its coverage and your responsibilities of ownership. The warranty policy is a separate document that should have been given to you by your dealer.

When your outboard motor needs scheduled maintenance, keep in mind that your Honda servicing dealer is specially trained in servicing Honda outboard motors. Your Honda servicing dealer is dedicated to your satisfaction and will be pleased to answer your questions and concerns.

Best Wishes,
Honda Motor Co., Ltd.

INTRODUCTION

A FEW WORDS ABOUT SAFETY

Your safety and the safety of others are very important. And using this outboard motor safely is an important responsibility.

To help you make informed decisions about safety, we have provided operating procedures and other information on labels and in this manual. This information alerts you to potential hazards that could hurt you or others.

Of course, it is not practical or possible to warn you about all the hazards associated with operating or maintaining a outboard motor. You must use your own good judgment.

You will find important safety information in a variety of forms, including:

- **Safety Labels** — on the outboard motor.
- **Safety Messages** — preceded by a safety alert symbol  and one of three signal words, DANGER, WARNING, or CAUTION.

These signal words mean:

 **DANGER**

You **WILL** be **KILLED** or **SERIOUSLY HURT** if you don't follow instructions.

 **WARNING**

You **CAN** be **KILLED** or **SERIOUSLY HURT** if you don't follow instructions.

 **CAUTION**

You **CAN** be **HURT** if you don't follow instructions.

- **Safety Headings** — such as *IMPORTANT SAFETY INFORMATION*.
- **Safety Section** — such as *OUTBOARD MOTOR SAFETY*.
- **Instructions** — how to use this outboard motor correctly and safely.

This entire book is filled with important safety information — please read it carefully.

CONTENTS

OUTBOARD MOTOR SAFETY	7
IMPORTANT SAFETY INFORMATION	7
Operator Responsibility	7
Refuel With Care	8
Carbon Monoxide Hazard	8
SAFETY LABEL LOCATIONS	9
CONTROLS & FEATURES	10
COMPONENT & CONTROL LOCATIONS	10
CONTROLS	12
Engine Stop Switch	12
Choke Knob	12
Throttle Grip	13
Throttle Friction Knob	13
Gearshift Lever	14
Recoil Starter Grip	14
Steering Friction Bolt	15
Tilt Lever	15
Transom Angle Adjusting Rod	16
Engine Cover Lock Lever	16
Fuel Priming Bulb	17
Fuel Cap Vent Knob	17
FEATURES	17
Fuel Gauge	17
Oil Pressure Indicator Light	17
Water Check Tube	17
Anode	18
INSTALLATION	19
INSTALLATION POSITION	19
INSTALLATION HEIGHT	19
OUTBOARD MOTOR ATTACHMENT	20

CONTENTS

INSTALLATION (continued)

MOTOR ANGLE FOR CRUISING	20
MOTOR ANGLE ADJUSTMENT	21
BATTERY CONNECTIONS	22
Battery Installation	23
EMERGENCY PROCEDURES	23
Connections to the Battery	24

BEFORE OPERATION

ARE YOU READY TO GET UNDER WAY?	25
Knowledge	25
Safety Apparel	25
IS YOUR OUTBOARD MOTOR READY TO GO?	25
Safety Inspection	26
Maintenance Inspection	26

OPERATION

SAFE OPERATING PRECAUTIONS	27
BREAK-IN PROCEDURE	27
PORTABLE FUEL TANK PLACEMENT AND CONNECTIONS	27
Fuel Tank Placement	27
Fuel Hose Connections	28
Fuel Priming	28
STARTING THE ENGINE	29
EMERGENCY STARTING	33
STOPPING THE ENGINE	34
Emergency Engine Stopping	34
Normal Engine Stopping	34
GEAR SHIFTING	35
STEERING	36
CRUISING	37
TILTING THE OUTBOARD MOTOR	38

SERVICING YOUR HONDA OUTBOARD MOTOR

THE IMPORTANCE OF MAINTENANCE	40
MAINTENANCE SAFETY	41
Safety Precautions	41

SERVICING YOUR HONDA OUTBOARD MOTOR (continued)	
TOOL KIT AND SPARE PARTS	42
MAINTENANCE SCHEDULE	43
REFUELING	44
FUEL RECOMMENDATIONS	45
COOLING SYSTEM CLEANING AND FLUSHING	46
Cleaning and Flushing With the Flush Kit	46
Cleaning and Flushing Without the Flush Kit	47
ENGINE OIL LEVEL CHECK	48
ENGINE OIL CHANGE	49
ENGINE OIL RECOMMENDATIONS	50
GEAR OIL LEVEL CHECK	51
GEAR OIL CHANGE	52
LUBRICATION	53
SPARK PLUG SERVICE	54
FUEL FILTER REPLACEMENT	55
RECOIL STARTER ROPE INSPECTION	57
ANODE REPLACEMENT	57
SHEAR PIN REPLACEMENT	58
ENGINE COVER LOCK ADJUSTMENT	59
HELPFUL TIPS & SUGGESTIONS	60
STORING YOUR OUTBOARD MOTOR	60
Storage Preparation	60
Storage Precautions	62
Removal From Storage	63
TRANSPORTING	63
TAKING CARE OF UNEXPECTED PROBLEMS	64
ENGINE WILL NOT START	64
BATTERY DOES NOT CHARGE	65
Fuse Replacement	65
SUBMERGED MOTOR	66

CONTENTS

TECHNICAL & CONSUMER INFORMATION	68
TECHNICAL INFORMATION	68
Serial Number Locations	68
Carburetor Modification for High Altitude Operation	69
Oxygenated Fuels	70
Emission Control System Information	71
Specifications	73
WIRING DIAGRAMS	75
CONSUMER INFORMATION	76
Honda Publications	76
Warranty Service Information	77
INDEX	78
QUICK REFERENCE INFORMATION	Inside back cover

OUTBOARD MOTOR SAFETY

IMPORTANT SAFETY INFORMATION

Honda BF8A outboard motor is designed for use with boats that have a suitable manufacturer's power recommendation, and other uses can result in injury to the operator or damage to the outboard motor and other property.

Most accidents can be prevented if you follow all instructions in this manual and on the outboard motor. The most common hazards are discussed below, along with the best way to protect yourself and others.

Operator Responsibility

- It is the operator's responsibility to provide the necessary safeguards to protect people and property. Know how to stop the engine quickly in case of emergency. Understand the use of all controls.
- Stop the engine immediately if anyone falls overboard, and do not run the engine while the boat is near anyone in the water.
- Always stop the engine if you must leave the controls for any reason.
- Attach the emergency stop switch lanyard securely to the operator.
- Always wear a PERSONAL FLOTATION DEVICE (PFD) while on the boat.
- Familiarize yourself with all laws and regulations relating to the boating and the use of outboard motors.
- Be sure that anyone who operates the outboard motor receives proper instruction.
- Be sure the outboard motor is properly mounted on the boat.
- Do not remove the engine cover while the engine is running.
- Do not attempt to modify the outboard motor.
- Do not remove any labels, covers, or safety devices; they are installed for your safety.

OUTBOARD MOTOR SAFETY

Refuel With Care

- Gasoline is extremely flammable, and gasoline vapor can explode. Refuel outdoors, in a well-ventilated area, with the engine stopped. Never smoke near gasoline, and keep other flames and sparks away.
- Remove any portable fuel tank from the boat for refueling. Keep the portable fuel tank away from the battery or other potential spark sources.
- Refuel carefully to avoid spilling fuel. Avoid overfilling the fuel tank.
- After refueling, tighten the filler cap securely. If any fuel is spilled, make sure the area is dry before starting the engine.

Carbon Monoxide Hazard

Exhaust gas contains poisonous carbon monoxide. Avoid inhalation of exhaust gas. Never run the engine in a closed garage or confined area.

OUTBOARD MOTOR SAFETY

SAFETY LABEL LOCATIONS

The labels shown here contain important safety information. Please read them carefully. These labels are considered permanent parts of your outboard motor. If a label comes off or becomes hard to read, contact an authorized Honda servicing dealer for a replacement.

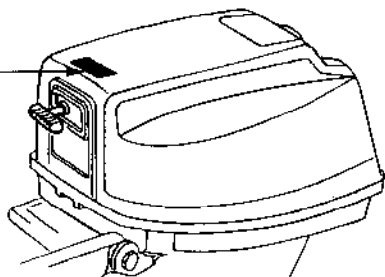
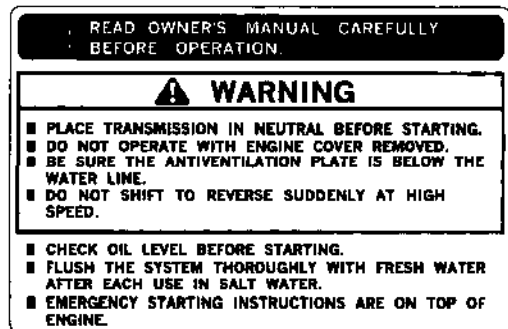

GASOLINE FLAMMABLE DANGER

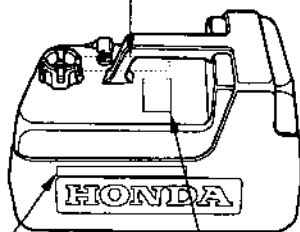

GASOLINE FLAMMABLE DANGER

DANGER
HARMFUL OR FATAL IF SWALLOWED.
KEEP OUT OF REACH OF CHILDREN.
IF SWALLOWED, DO NOT INDUCE
VOMITING. CALL A PHYSICIAN
IMMEDIATELY.

CONTROLS & FEATURES

COMPONENT & CONTROL LOCATIONS

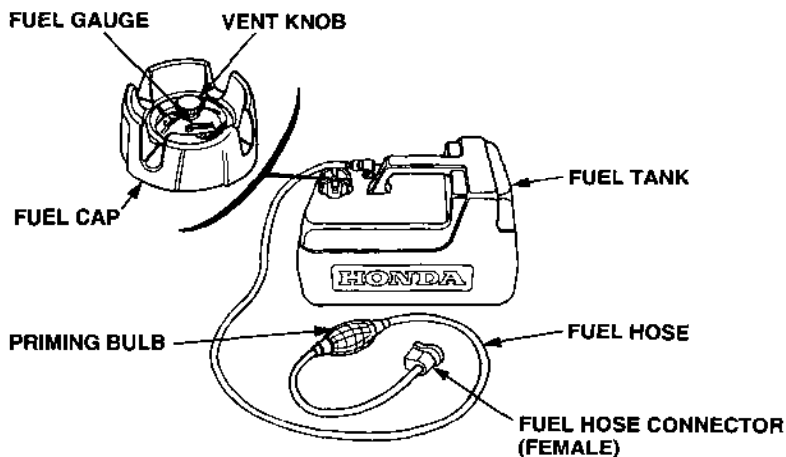
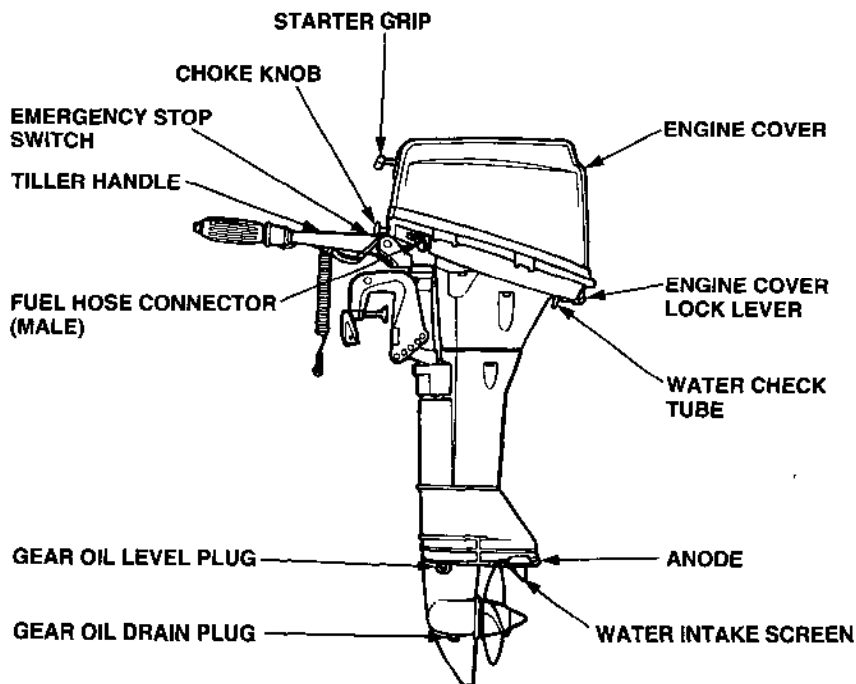

CONTROLS & FEATURES

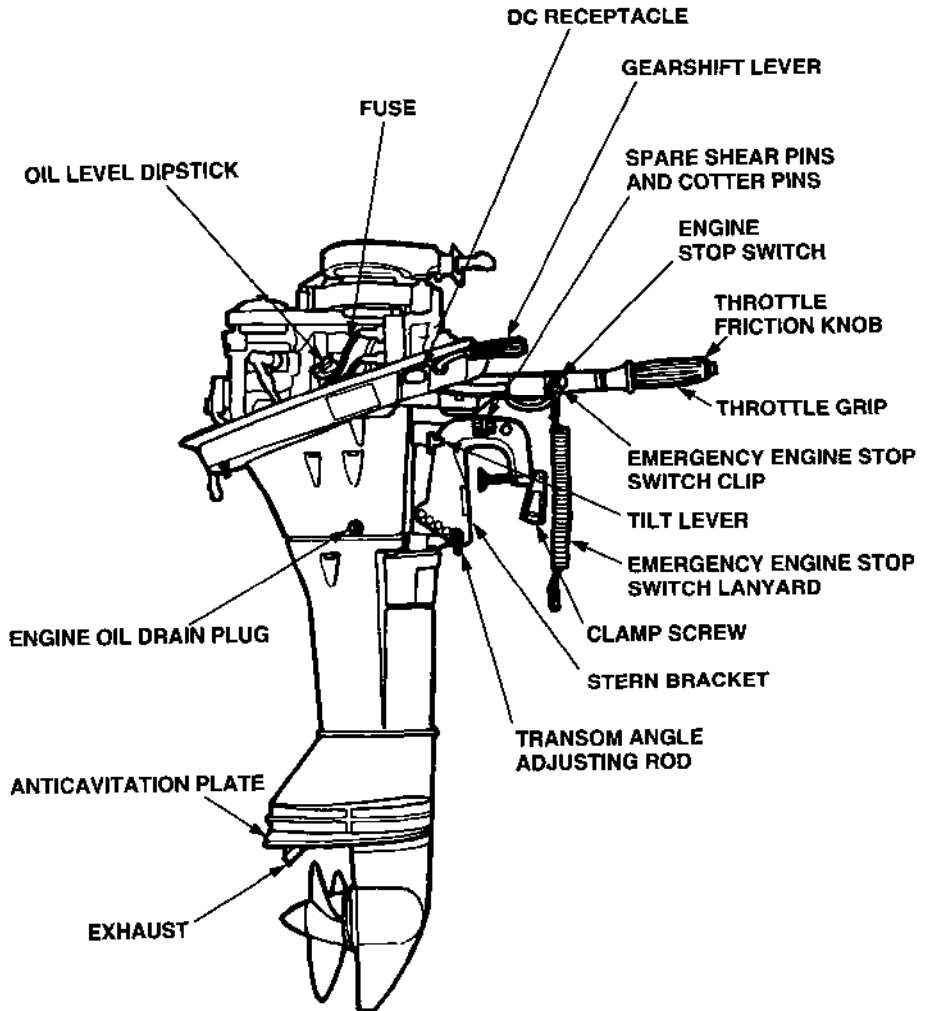

CONTROLS & FEATURES

CONTROLS

Engine Stop Switch

The engine stop switch has controls for normal engine stopping and emergency engine stopping.

In normal operation, press the engine stop button to stop the engine.

A clip and lanyard system stops the engine automatically if the operator falls away from the controls.

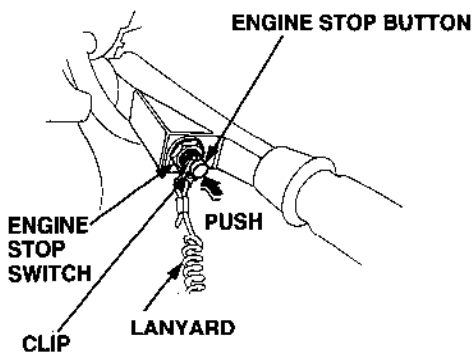

The switch clip must be inserted in the engine stop switch in order for the engine to start and run. The other end of the lanyard attaches to the operator's wrist. If the operator falls away from the controls, the lanyard pulls the clip out of the switch.

Always attach the lanyard to your wrist before operating the outboard motor.

A spare switch clip is supplied with the tool kit.

Choke Knob

The choke knob opens and closes the choke valve in the carburetor.

The CLOSED position enriches the fuel mixture for starting.

The OPEN position provides the correct fuel mixture for operation after starting, and for restarting a warm engine.

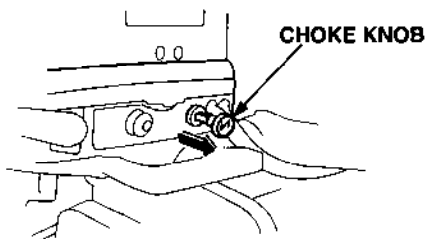

Throttle Grip

The throttle grip controls engine speed.

An index mark on the tiller arm indicates throttle position.

The gearshift mechanism limits throttle grip movement when the gearshift lever (p. 14) is in the R (reverse) or N (neutral) position.

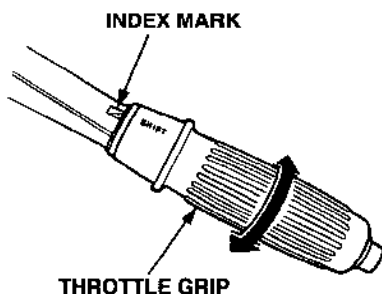

Throttle Friction Knob

The throttle friction knob adjusts resistance to throttle grip rotation.

Turn the knob clockwise to increase friction for holding a throttle setting while cruising.

Turn the knob counterclockwise to decrease friction for easy throttle grip rotation.

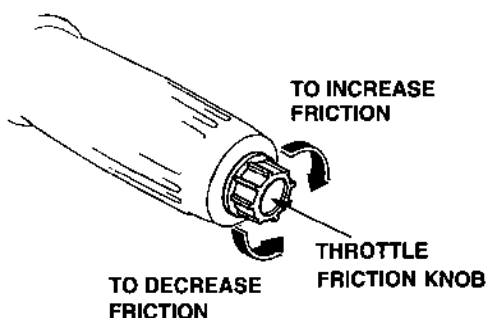

CONTROLS & FEATURES

Gearshift Lever

The gearshift lever is used to select F (forward), N (neutral), or R (reverse) gears.

The engine can be started with the gearshift lever in the N (neutral) position only.

If the gearshift lever is in the F (forward) or R (reverse) position, the recoil starter will not operate.

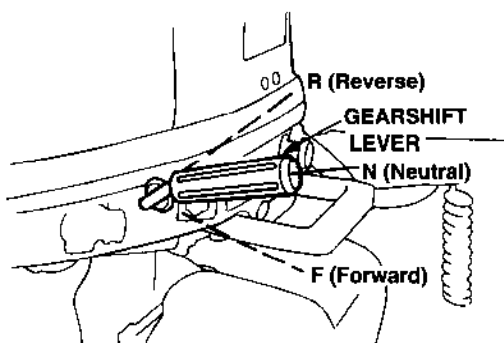

Recoil Starter Grip

Pull the starter grip to operate the recoil starter for starting the engine manually.

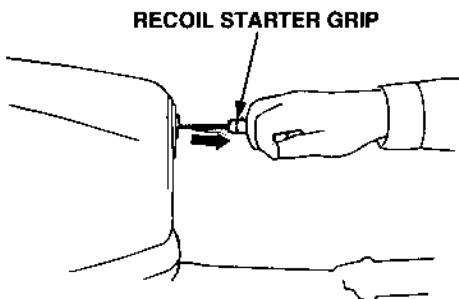

Steering Friction Bolt

The steering friction bolt adjusts steering resistance.

Turn the bolt clockwise to increase friction for holding a steady course while cruising or to prevent the outboard motor from swinging while trailering the boat.

Turn the bolt counterclockwise to reduce steering friction.

STEERING FRICTION BOLT

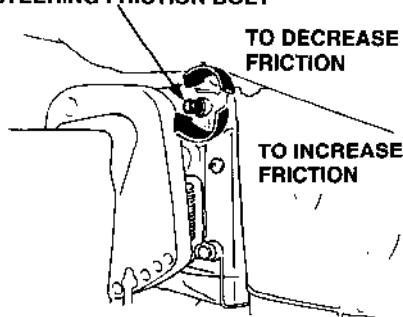

Tilt Lever

The tilt lever enables the outboard motor to be raised for shallow water operation, beaching, launching, or mooring.

To tilt, move the lever to the TILT position, then raise the outboard motor until the tilt mechanism engages at 30°, 45° or 70° (p. 38).

To return the outboard motor to the normal running position, move the tilt lever to the RUN position, raise the outboard motor slightly to disengage the tilt mechanism, then slowly lower the engine.

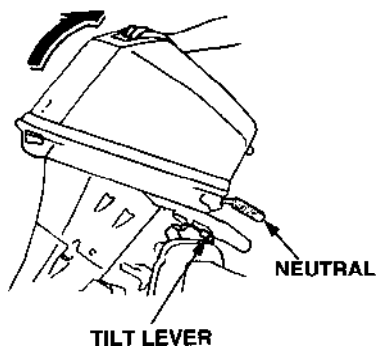

CONTROLS & FEATURES

Transom Angle Adjusting Rod

The transom angle adjusting rod is used to adjust the angle of the outboard motor in the normal operating position (see page 21).

To adjust, first tilt the outboard motor, so it is not resting on the rod.

Push the rod in, and turn the end of the rod up, so the latch will fall into the line with the rod.

Remove the rod, and reinsert it in the desired.

Remove the rod in, and turn the end of the rod down, so the latch will fall to the locked position. Then release the rod.

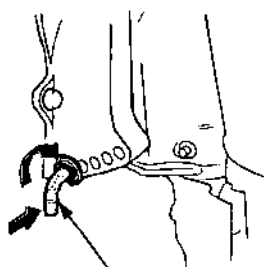

TRANSOM ANGLE ADJUSTING ROD

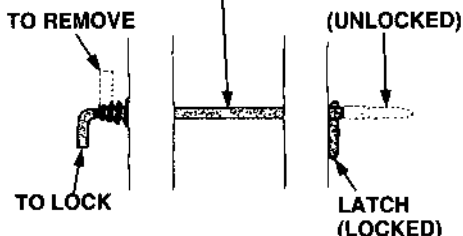

Engine Cover Lock Lever

The engine cover lock lever fastens the cover to the outboard motor.

To remove the cover, move the lever to the unlocked position, then lift off the cover.

To install the cover, position the cover on the outboard motor, then move the lever to the locked position.

ENGINE COVER LOCK LEVER

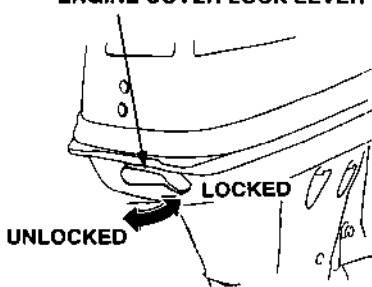

Fuel Priming Bulb

A priming bulb is built into the fuel hose that connects the portable fuel tank to the outboard motor.

Before operating the outboard motor, squeeze the priming bulb until it feels firm. This will ensure that fuel is supplied to the engine (see page 27).

Fuel Cap Vent Knob

The cap is provided with a vent knob to seal the portable fuel tank for carrying it to and from the boat. Open the vent knob 2 or 3 turns before operating the outboard motor (see page 28).

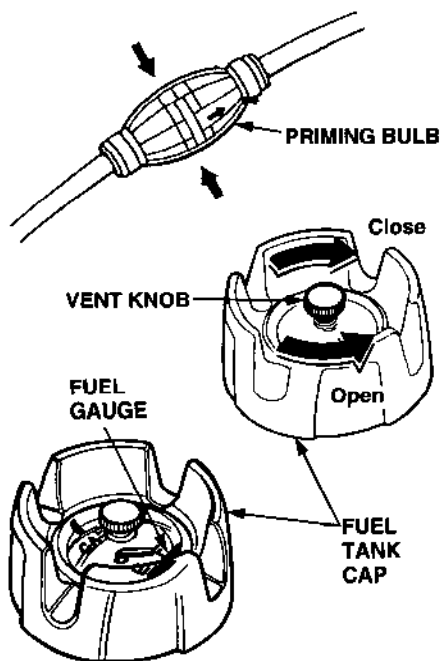

FEATURES

Fuel Gauge

A fuel gauge is built into the cap of the portable fuel tank (see page 27).

Oil Pressure Indicator Light

The oil pressure indicator light should remain lit while the engine is running. The light indicates that oil pressure is OK (see page 31).

Water Check Tube

Water should flow from the water check hole while the engine is running. This shows that water is circulating through the engine cooling system (see page 32).

OIL PRESSURE INDICATOR LIGHT

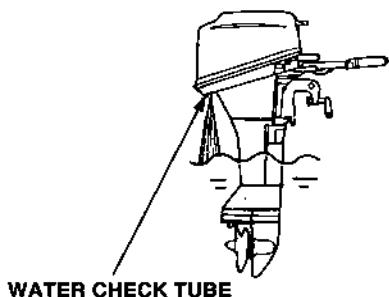
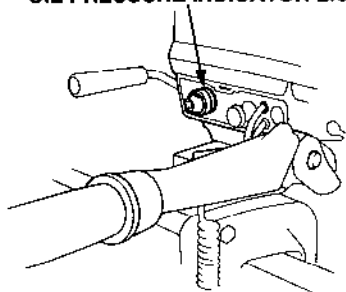

WATER CHECK TUBE

CONTROLS & FEATURES

Anode

The anode is a sacrificial material which helps to protect the outboard motor from corrosion.

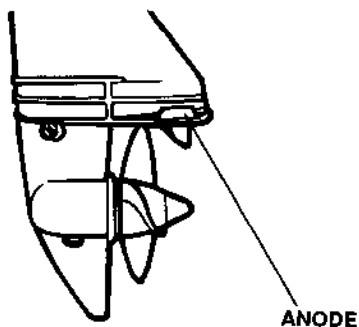

INSTALLATION

It is your responsibility to choose a boat suitable for the outboard motor.

⚠ WARNING

Do not exceed the boat manufacturer's power recommendation. Damage and injury may result.

INSTALLATION POSITION

Install at the stern, at the center line of the boat.

INSTALLATION HEIGHT

For proper propeller depth and engine cooling, the boat and outboard motor transom height must match.

Three outboard motor transom heights are available. Match your boat's transom height to the outboard motor transom height shown below.

Outboard Motor	
Type	Transom Height
Short : S	16.5 in (420 mm)
Long : L	22.4 in (570 mm)
Extra Long : X	25.5 in (648 mm)

The anticavitation plate should be 0 – 2 in (0 – 50 mm) below the bottom of the boat. With the boat in the water, loaded and motor off, the anticavitation plate should be about 100 mm (3.9 in) below the surface of the water.

NOTICE

Running the outboard motor without sufficient cooling water will damage the water pump and overheat the engine.

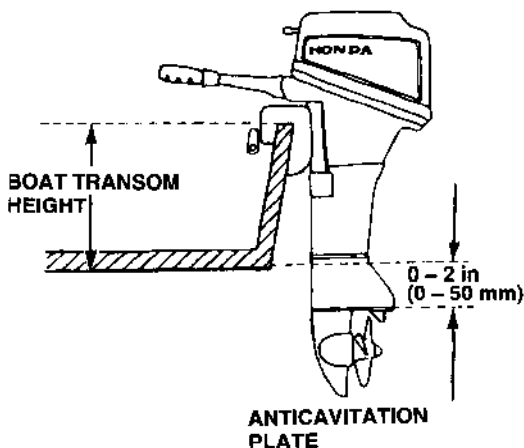
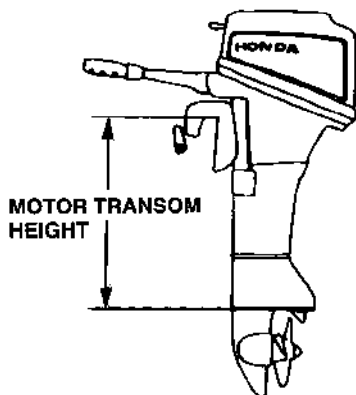
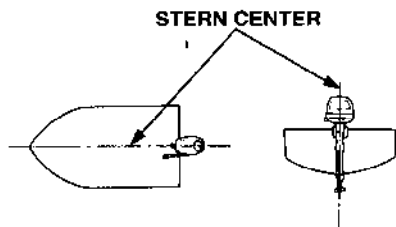

INSTALLATION

OUTBOARD MOTOR ATTACHMENT

Attach the stern bracket to the transom and tighten the clamp screws.

NOTICE

- Before operating the boat, check the tightness of the clamp screws.
- Tie a rope through the hole in the stern bracket and secure the other end of the rope to the boat. This will prevent accidental loss of the motor.
- The holes in the clamp screw handles may be padlocked together to prevent theft of the motor.

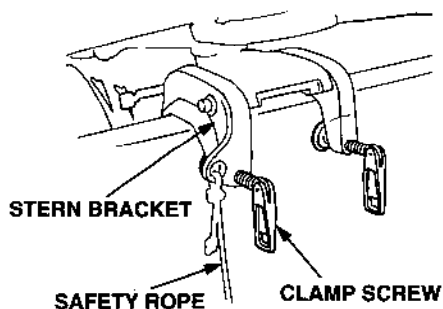

MOTOR ANGLE FOR CRUISING

Adjust the motor so the propeller shaft is parallel with the water surface.

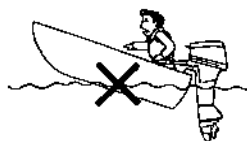

**INCORRECT
CAUSES BOAT TO
"SQUAT"**

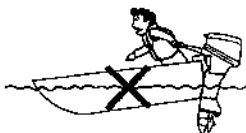

**INCORRECT
CAUSES BOAT TO
"PLOW"**

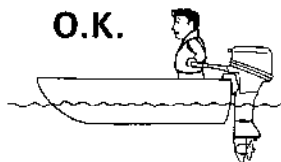

**O.K.
CORRECT
GIVES MAXIMUM PERFORMANCE**

MOTOR ANGLE ADJUSTMENT

If the propeller shaft is not parallel with the water surface, adjust by changing the transom angle adjusting rod position.

There are four adjusting stages.

1. Push in (A) the adjusting rod, twist upwards (B) and pull out to remove.
2. Inserting the rod in the proper hole, twist it down to lock.

NOTICE

To prevent damage to the motor or boat, make sure the transom angle adjusting rod is locked.

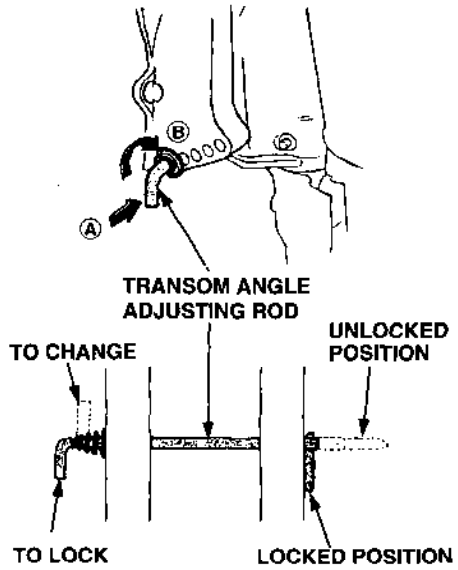

INSTALLATION

BATTERY CONNECTIONS

Honda BF8A outboard motor produce a 12-volt, 5-ampere battery-charging current and are equipped for connection to a 12-volt battery. The battery-charging circuit is protected by a 5-ampere fuse located in the engine compartment.

The outboard motor's 12-volt output is intended for battery charging only. Lights and electrical accessories for the boat should be connected to the battery.

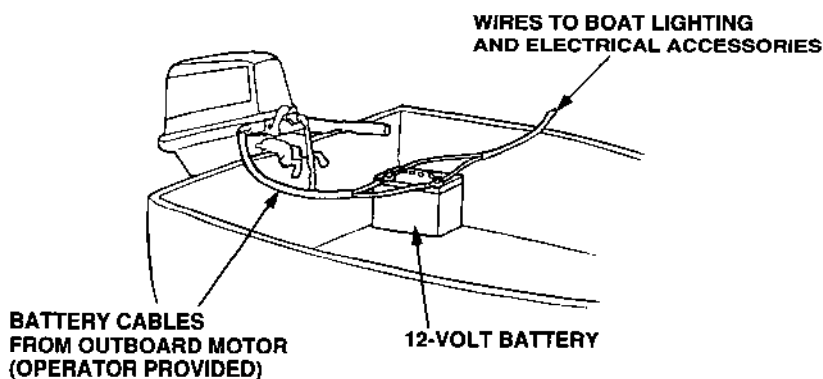

INSTALLATION

The receptacle is provided with a rubber cap, which should be attached when the plug is removed, in order to keep the receptacle clean and dry.

To prepare the outboard motor for connection to a battery, pull the plug out of its rubber boot, route suitable electrical wires through the boot, and screw them to the plug positive (+) and negative (-) terminals. Coat the plug terminals with grease, and reinstall the plug in the rubber boot.

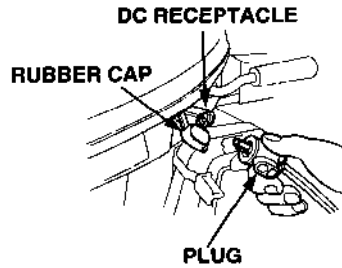

Battery Installation

Place the battery in a corrosion-resistant battery box that is securely mounted in a location away from the fuel tank and protected from contact with water.

⚠ WARNING

The battery contains sulfuric acid (electrolyte), which is highly corrosive and poisonous.

Getting electrolyte in your eyes or on your skin can cause serious burns.

Wear protective clothing and eye protection when working near the battery.

EMERGENCY PROCEDURES

Eyes — Flush with water from a cup or other container for at least 15 minutes (water under pressure can damage the eye). Immediately call a physician, local poison control center, or 911.

Skin — Remove contaminated clothing. Flush the skin with large quantities of water. Call a physician immediately.

Swallowing — Drink water or milk. Call your local poison control center or a physician immediately.

INSTALLATION

Connections to the Battery

Connect the positive (+) battery cable to the positive (+) battery terminal, then connect the negative (-) battery cable to the negative (-) battery terminal.

The negative (-) battery cable should always be removed from the battery when connecting or disconnecting the positive (+) battery cable, so tools cannot cause a short circuit if they touch a grounded part while being used on the positive (+) battery terminal fitting.

NOTICE

Be careful to avoid connecting the battery in reverse polarity, as that will damage the battery-charging system in the outboard motor.

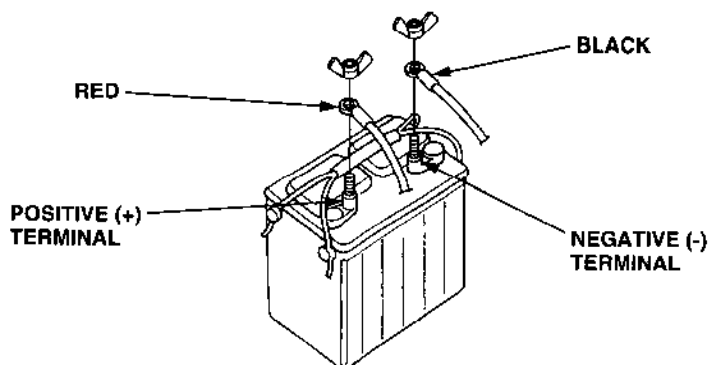

BEFORE OPERATION

ARE YOU READY TO GET UNDERWAY?

Your safety is your responsibility. A little time spent in preparation will significantly reduce your risk of injury.

Knowledge

Read and understand this manual. Know what the controls do and how to operate them.

Familiarize yourself with the outboard motor and its operation before you get underway. Know what to do in case of emergencies.

Familiarize yourself with all laws and regulations relating to boating and the use of outboard motors.

Safety Apparel

Always wear a PFD while on the boat. Attach the emergency stop switch lanyard securely to your PFD or your wrist.

IS YOUR OUTBOARD MOTOR READY TO GO?

For your safety, and to maximize the service life of your equipment, it is very important to take a few moments before you operate the outboard motor to check its condition. Be sure to take care of any problem you find, or have your servicing dealer correct it, before you operate the outboard motor.

⚠ WARNING

Improperly maintaining this outboard motor, or failing to correct a problem before operation, could cause a malfunction in which you could be seriously injured.

Always perform a preoperation inspection before each operation, and correct any problem.

BEFORE OPERATION

Safety Inspection

- Look around for signs of oil or gasoline leaks. Make sure the fuel tank is in good condition and properly secured in the boat (see page 27). Check that the fuel hose is undamaged and properly connected (see page 28). Wipe up any spills before starting the engine.
- Check the stern bracket to be sure the outboard motor is securely installed.
- Check that all controls are operating properly.
- Replace any damaged parts.
- Check that all fasteners are in place and securely tightened.

Maintenance Inspection

- Check the engine oil level (see page 48). Running the engine with a low oil level can cause engine damage.
- Check to be sure the propeller is undamaged, and the retaining nut is secured with a cotter pin (see page 58).
- Check that the anode is securely attached to the anticavitation plate and is not excessively worn (see page 57). The anode helps to protect the outboard motor from corrosion.
- Make sure the tool kit and spare parts are onboard (see page 42). Replace any missing items.
- Check the fuel level in the fuel tank (see page 44).

OPERATION

SAFE OPERATING PRECAUTIONS

To safely realize the full potential of this outboard motor, you need a complete understanding of its operation and a certain amount of practice with its controls.

Before operating the outboard motor for the first time, please review the *IMPORTANT SAFETY INFORMATION* on page 7 and the chapter titled *BEFORE OPERATION*.

For your safety, avoid starting or operating the engine in an enclosed area, such as a garage. Your engine's exhaust contains poisonous carbon monoxide gas which can collect rapidly in an enclosed area and cause illness or death.

BREAK-IN PROCEDURE

Proper break-in procedure allows the moving parts to wear in smoothly for best performance and long service life.

For the first 10 hours, run the outboard motor at low speed, and avoid full-throttle operation.

PORTABLE FUEL TANK PLACEMENT AND CONNECTIONS

Fuel Tank Placement

Place the portable fuel tank in a well-ventilated location, away from direct sunlight.

▲ WARNING

Gasoline is highly flammable and explosive.

You can be burned or seriously injured when handling fuel.

- Stop the engine and keep heat, sparks, and flame away.
- Handle fuel only outdoors.
- Wipe up spills immediately.

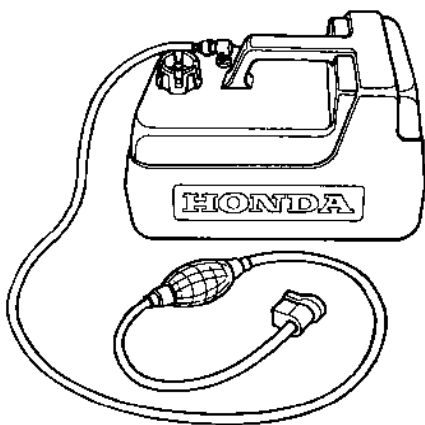

OPERATION

To ensure that the outboard motor will be able to draw fuel from the tank, place the tank within 6 feet of the outboard motor and not more than 3 feet below the fuel connector on the outboard motor.

Secure the portable fuel tank in the boat, so it won't move around and become damaged.

Before use, open the fuel tank vent by turning the vent knob at least 2 or 3 turns counterclockwise.

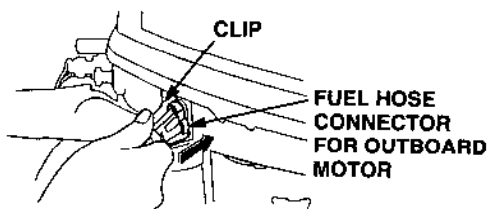
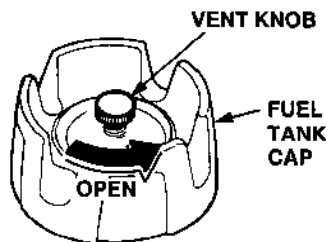

Fuel Hose Connections

Connect the fuel hose to the tank and the outboard motor, as shown. Be sure both connectors snap securely into place.

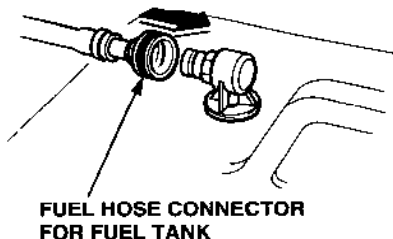

Fuel Priming

Hold the priming bulb with the outlet end higher than the inlet end. Squeeze the primer bulb several times, until it feels firm, indicating that fuel has reached the carburetor.

Check to be sure there are no fuel leaks before starting the engine.

Do not squeeze the priming bulb when the engine is running, because that could flood the carburetor.

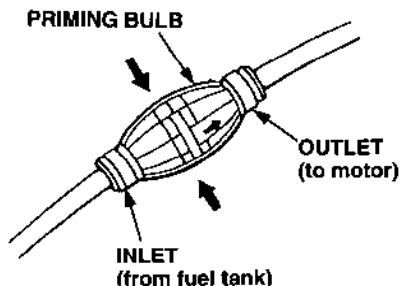

STARTING THE ENGINE

1. Put the emergency engine stop switch clip in the engine stop switch, and attach the lanyard to your wrist.

The engine will not start or run, unless the clip is in the switch.

The emergency engine stop switch clip and lanyard system is a safety device that will stop the engine if you fall away from the controls while operating the boat.

Always attach the lanyard to your wrist before starting the engine.

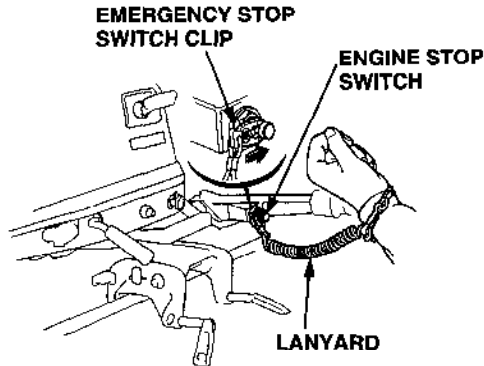

2. Check the position of the gearshift lever. It must be in the N (neutral) position for starting.

If the gearshift lever is in the F (forward) or R (reverse) position, the recoil starter will not operate, and the electric starter button (applicable models) is blocked.

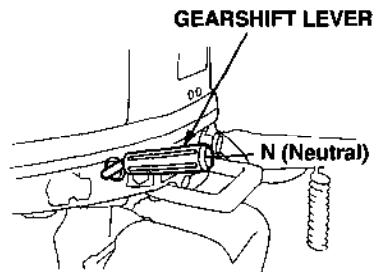

OPERATION

3. Align the throttle grip **START** position with the **MARK** on the tiller handle.

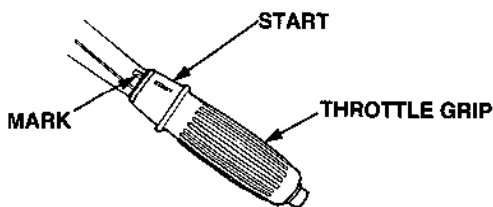

4. To start a cold engine, pull out the choke knob. To restart a warm engine, leave the choke knob pushed in.

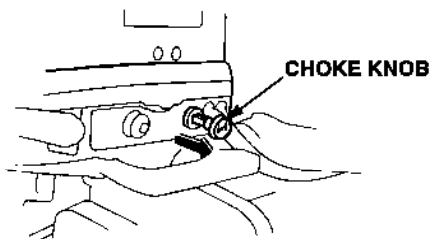

5. Pull the recoil starter grip slowly until you feel resistance, then pull briskly.

NOTICE

- Do not allow the starter grip to snap back against the engine. Return it gently to prevent damage to the starter.
- Do not pull the starter grip while the engine is running, as that may damage the starter.

If the engine fails to start, check the engine stop switch clip.

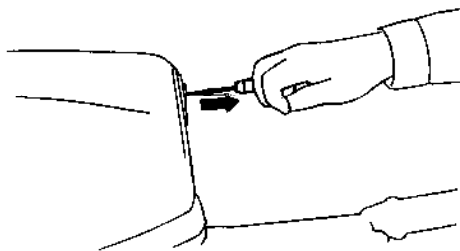

6. After starting, check the oil pressure indicator light. The light should be on while the engine is running. If the light is off, stop the engine immediately, check the engine oil level, and inspect the engine for oil leaks.

OIL PRESSURE INDICATOR LIGHT

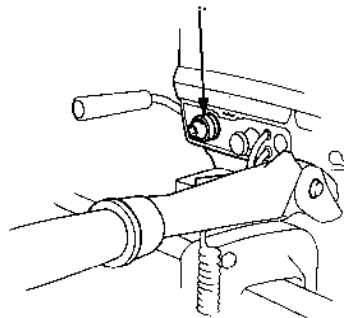

If the oil level is OK, but the light stays off while the engine is running, take the motor to an authorized Honda marine dealer immediately.

OPERATION

7. After starting, be sure water is flowing out of the water check tube.

NOTICE

If water does not flow out, or if steam comes out, stop the engine. Check to see if the screen in the cooling water inlet is obstructed. Do not operate the engine until the problem has been corrected.

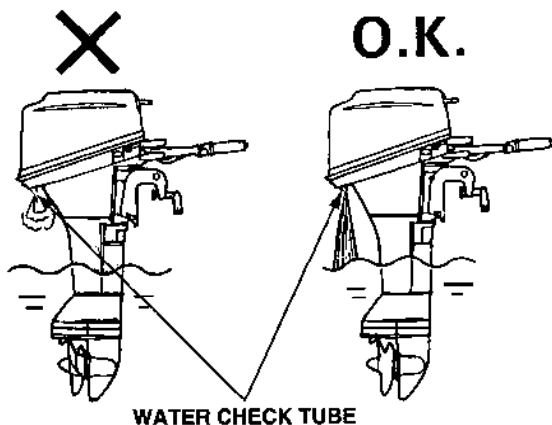

8. If the choke was used, push it in gradually as the engine warms up.
9. Before leaving the dock, check the operation of the emergency engine stop switch.

EMERGENCY STARTING

If the recoil starter is not working properly, the engine can be started with the spare starter rope in the tool kit.

1. Remove the engine cover.
2. Remove the recoil starter by removing the three 6 mm bolts.
3. Follow steps 1 through 4 of the normal engine starting procedure (see pages 29 and 30).
4. Wind the spare rope clockwise around the pulley, and then pull it straight out to start the engine.

NOTICE

Keep clear of moving parts.

5. Leave the recoil starter off and reinstall engine cover.

⚠ WARNING

Exposed moving parts can cause injury. Use extreme care when installing the engine cover. Do not operate the outboard motor without the engine cover.

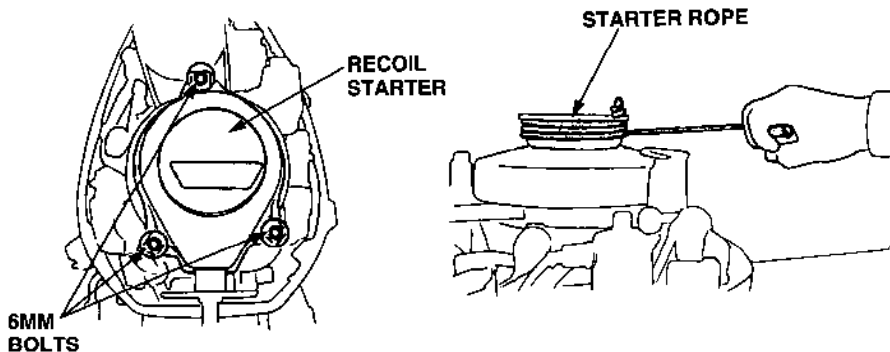

OPERATION

STOPPING THE ENGINE

Emergency Engine Stopping

Disengage the emergency engine stop switch clip from the engine stop switch by pulling the lanyard.

It is a good idea to stop the engine with the emergency engine stop switch lanyard from time to time to be sure that the switch is operating properly.

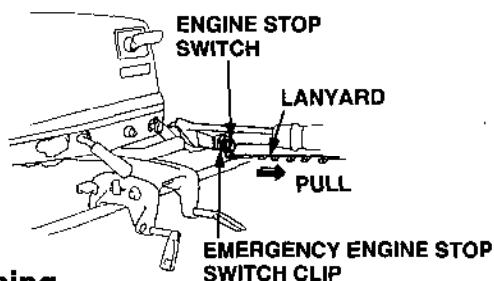

Normal Engine Stopping

1. Turn the throttle grip to the **SHIFT** position, and move the gearshift lever to the **N (neutral)** position.

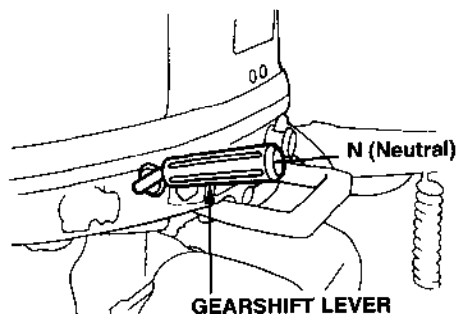
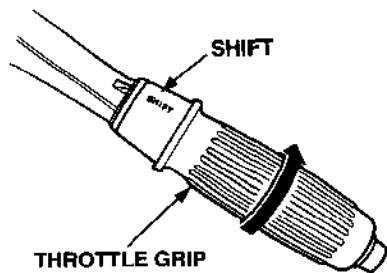

2. Push the engine stop switch button until the engine stops.

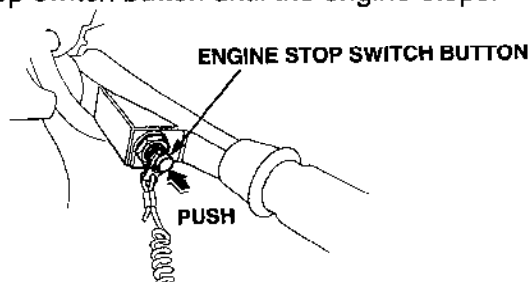

In the event that the engine does not stop when you push the engine stop switch, pull the emergency engine stop switch lanyard. If the engine continues to run, pull the choke knob to stop the engine.

GEAR SHIFTING

Put the tilt lever in the RUN position to prevent the outboard motor from tilting up when operating in reverse (refer to page 38).

The gearshift lever has 3 positions : FORWARD, NEUTRAL, and REVERSE. An indicator at the base of the gearshift lever aligns with letters F, N, or R on the engine case to show the gear that has been selected.

Turn the throttle grip to SHIFT to decrease engine speed before moving the gearshift level.

NOTICE

When operating in reverse, proceed with caution to avoid hitting any underwater obstructions with the propeller.

The gear shift mechanism limits throttle opening in the N (neutral) and R (reverse) positions. The outboard motor allows the throttle to be opened to FAST with the gear shift lever in the F (forward) position.

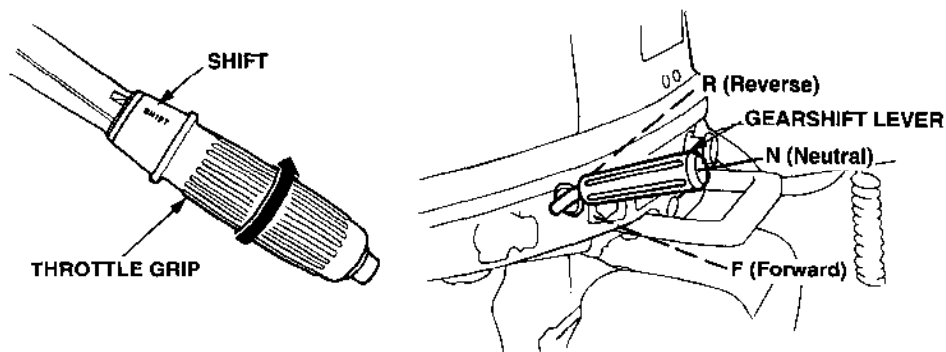

OPERATION

STEERING

To turn to the right, swing the tiller handle to the left. To turn to the left, swing the tiller handle to the right.

Boats equipped with a remote control steering wheel are controlled in the same way as a car.

LEFT TURN



Swing the tiller handle to the right.

RIGHT TURN

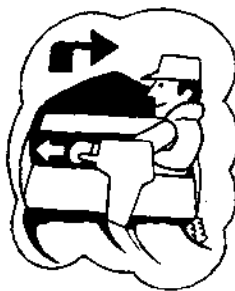

Swing the tiller handle to the left.

The steering friction should be adjusted so that stable boat operation is maintained with a minimum of operator effort.

STEERING FRICTION BOLT

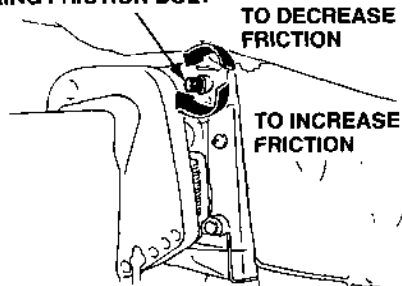

CRUISING

With the gearshift lever in the forward position F, turn the throttle grip toward FAST to increase speed. For normal cruising, open the throttle about 3/4.

To hold the throttle at a steady setting, turn the throttle friction knob clockwise. To free the throttle grip for manual speed control, turn the friction knob counterclockwise.

For best performance, passengers and equipment should be distributed evenly to balance the boat.

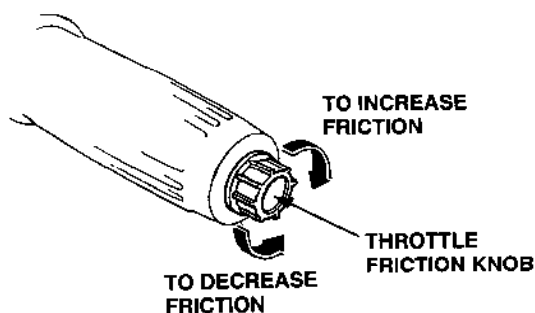
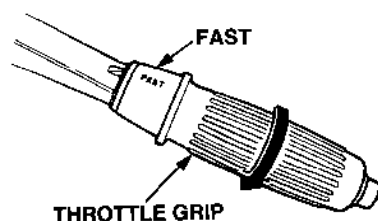
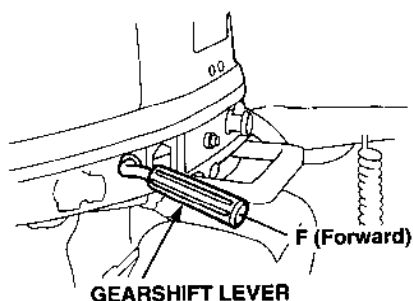

OPERATION

TILTING THE OUTBOARD MOTOR

Tilt the motor prevent the propeller and gear case from hitting bottom when the boat is beached or stopped in shallow water.

1. Stop the engine and put the gearshift lever into **NEUTRAL**.
2. Pull the tilt lever toward you, set the lever in the **TILT** position, and raise the engine to either the 30°, 45° or 70° tilt position.

NOTICE

Do not use the throttle grip to tilt the outboard motor.

3. To return the engine to the normal **RUN** position, move the tilt lever away from you until it stops, tilt the engine up slightly, then lower the engine slowly.

NOTICE

- Make sure water comes out from the cooling water check tube.
- When the outboard motor is tilted, cruise at low speed.
- Never operate in reverse when the outboard motor is tilted, because the outboard motor will rise suddenly.

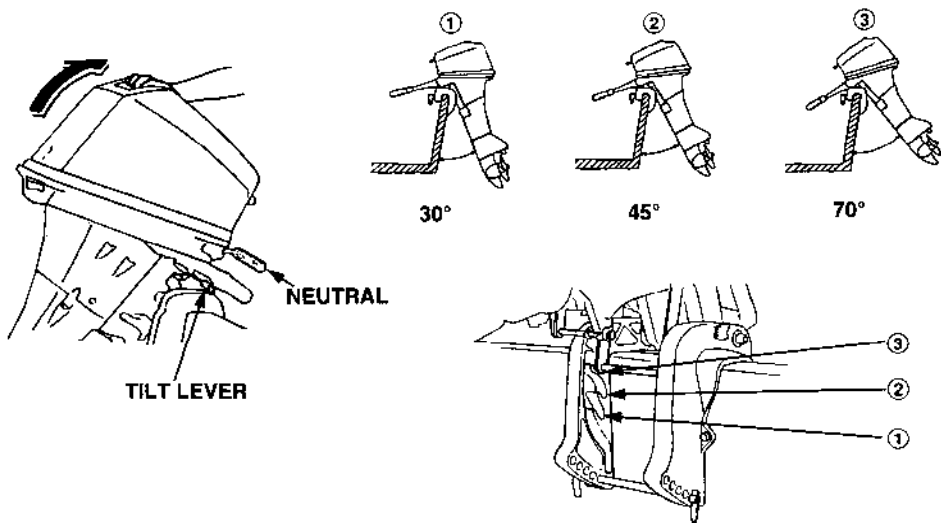

NOTICE

To avoid damaging the motor, be very careful when mooring a boat, especially when its motor is tilted up. Don't allow the motor to strike against the pier or other boats.

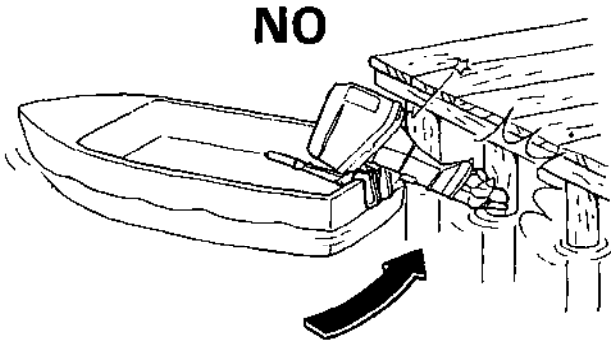

SERVICING YOUR HONDA OUTBOARD MOTOR

THE IMPORTANCE OF MAINTENANCE

Good maintenance is essential for safe, economical, and trouble-free operation. It will also help reduce air pollution.

WARNING

Improperly maintaining this outboard motor, or failure to correct a problem before operation, can cause a malfunction in which you can be seriously hurt or killed.

Always follow the inspection and maintenance recommendations and schedules in this owner's manual.

To help you properly care for your outboard motor, the following pages include a maintenance schedule, routine inspection procedures, and simple maintenance procedures using basic hand tools. Other service tasks that are more difficult, or require special tools, are best handled by professionals and are normally performed by a Honda technician or other qualified mechanic.

The maintenance schedule applies to normal operating conditions. If you operate your outboard motor under unusual conditions, consult an authorized Honda marine dealer for recommendations applicable to your individual needs and use.

Remember that your authorized Honda marine dealer knows your outboard motor best and is fully equipped to maintain and repair it.

To ensure the best quality and reliability, use only new, genuine Honda parts or their equivalents for repair and replacement.

Maintenance, replacement, or repair of emission control devices and systems may be performed by any engine repair establishment or individual, using parts that are “certified” to EPA standards.

SERVICING YOUR HONDA OUTBOARD MOTOR

MAINTENANCE SAFETY

Some of the most important safety precautions follow. However, we cannot warn you of every conceivable hazard that can arise in performing maintenance. Only you can decide whether or not you should perform a given task.

⚠ WARNING

Failure to properly follow maintenance instructions and precautions can cause you to be seriously hurt or killed.

Always follow the procedures and precautions in the owner's manual.

Safety Precautions

- Make sure the engine is off before you begin any maintenance or repairs. This will eliminate several potential hazards:
 - **Carbon monoxide poisoning from engine exhaust.**
Be sure there is adequate ventilation whenever you operate the engine.
 - **Burns from hot parts.**
Let the engine and exhaust system cool before touching.
 - **Injury from moving parts.**
Do not run the engine unless instructed to do so.
- Read the instructions before you begin, and make sure you have the tools and skills required.
- To reduce the possibility of fire or explosion, be careful when working around gasoline. Use only a nonflammable solvent, not gasoline, to clean parts. Keep cigarettes, sparks, and flames away from all fuel-related parts.

SERVICING YOUR HONDA OUTBOARD MOTOR

TOOL KIT AND SPARE PARTS

The following tools and spare parts are supplied with the outboard motor for maintenance, adjustment, and emergency repairs.

Spare shear pins and cotter pins are located on the stern bracket.

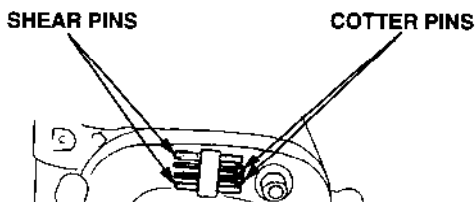

Tool Kit

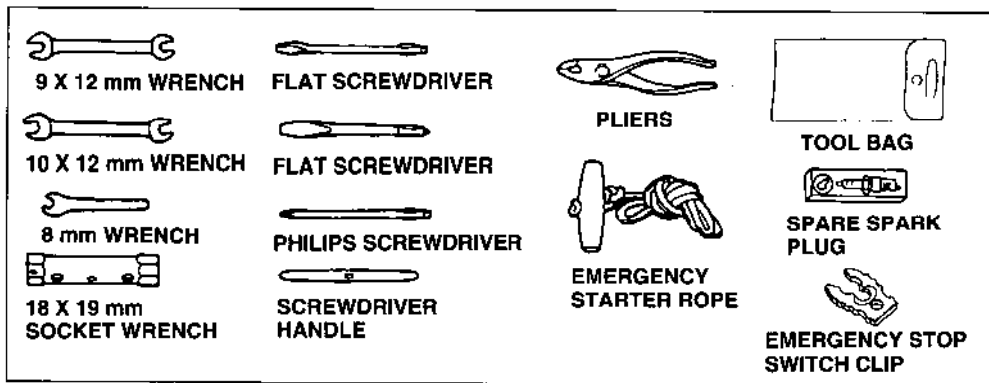

Flush Kit

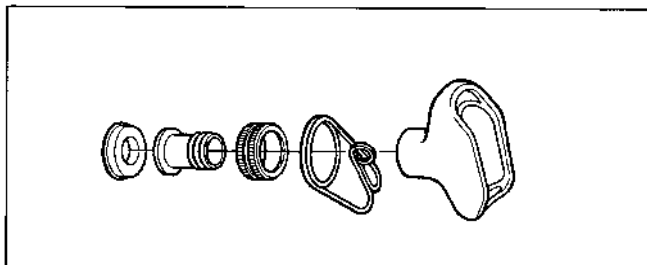

SERVICING YOUR HONDA OUTBOARD MOTOR

MAINTENANCE SCHEDULE

REGULAR SERVICE PERIOD (3)		EACH USE	FIRST MONTH OR 20 HRS	EVERY 6 MONTHS OR 100 HRS	EVERY YEAR OR 200 HRS.
ITEM	Perform at every indicated month or operating hour interval, whichever comes first.				
•	Engine oil	Check level	○		
		Change		○	○
	Gear case oil	Check level			○
		Change		○	○
		Check for water contamination			○
	Starter rope	Check			○
	Carburetor linkage	Check		○ (2)	○ (2)
•	Valve clearance	Check-Readjust		○ (2)	
•	Spark plug	Check-Clean			○
	Shear pin	Check			○
	Propeller (cotter pin)	Check	○		
	Anode	Check	○		
	Lubrication	Grease		○ (1)	○ (1)
	Fuel tank and filter	Clean			○
•	Thermostat	Check			○ (2)
	Fuel filter	Change			○
•	Fuel line	Check (Replace if necessary)	○	Every 2 years (2)	

- Emission-related items.

- NOTE:** (1) Lubricate more frequently when used in salt water.
 (2) These items should be serviced by an authorized Honda marine dealer, unless the owner has the proper tools and is mechanically proficient. See the Honda Shop Manual.
 (3) For professional commercial use, log hours of operation to determine proper maintenance intervals.

SERVICING YOUR HONDA OUTBOARD MOTOR

REFUELING

Fuel tank capacity
3.2 US gal (12.0 ℓ, 2.6 Imp gal)

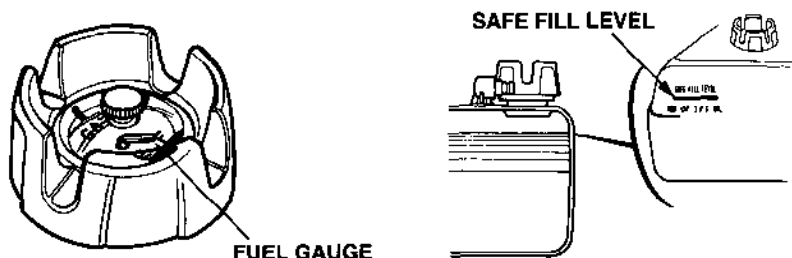

Check the fuel gauge and refill the tank to the SAFE FILL LEVEL mark if necessary

⚠ WARNING

Gasoline is highly flammable and explosive.

You can be burned or seriously injured when handling fuel.

- Stop the engine and keep heat, sparks, and flame away.
- Handle fuel only outdoors.
- Wipe up spills immediately.

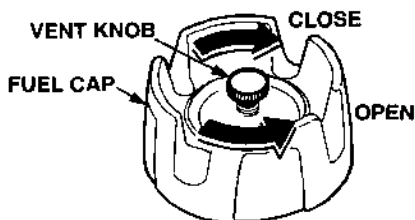

Remove the fuel tank from the boat for refilling. Turn the vent knob counter-clockwise to the open position and remove the fuel cap.

Refuel in a well-ventilated area. Fill the fuel tank up to the SAFE FILL LEVEL mark only. Inspect the condition of the fuel cap gasket and replace if necessary.

After refilling, install and tighten the fuel cap securely. Turn the vent knob clockwise to the closed position. Return the fuel tank to the boat.

SERVICING YOUR HONDA OUTBOARD MOTOR

FUEL RECOMMENDATIONS

Use unleaded gasoline with a pump octane rating of 86 or higher.

This outboard motor is certified to operate on unleaded gasoline. Unleaded gasoline produces fewer engine and spark plug deposits and extends exhaust system life.

Never use stale or contaminated gasoline or an oil/gasoline mixture. Avoid getting dirt or water in the fuel tank.

Occasionally you may hear light "spark knock" or "pinging" (metallic rapping noise) while operating under heavy loads. This is no cause for concern.

If spark knock or pinging occurs at a steady engine speed, under normal load, change brands of gasoline. If spark knock or pinging persists, see an authorized Honda marine dealer.

NOTICE

Running the engine with persistent spark knock or pinging can cause engine damage.

Running the engine with persistent spark knock or pinging is misuse, and the *Distributor's Limited Warranty* does not cover parts damaged by misuse.

SERVICING YOUR HONDA OUTBOARD MOTOR

COOLING SYSTEM CLEANING AND FLUSHING

After each use in salt water or dirty water, thoroughly clean and flush the outboard motor.

⚠ WARNING

- For safety, the propeller must be removed.
- Be sure the outboard motor is securely mounted, and do not leave it unattended while running.
- Keep children and pets away from the area, and stay clear of moving parts during this procedure.

NOTICE

Running the engine without water can cause serious engine damage due to overheating. Be sure that water flows from the water check hole while the engine is running. If not, stop the engine and determine the cause of the problem.

Cleaning and Flushing With the Flush Kit

1. Wash the outside of the outboard motor with clean, fresh water.
2. Flush the cooling system, using the Honda flush kit (optional).
 - a. Attach a hose from a fresh water faucet to the water hose connector of the flush kit.
 - b. Remove the propeller, and clip the flush kit rubber fitting over the water intake as shown.
 - c. Turn on the fresh water supply to the hose.
 - d. Start the engine and run in neutral for 10 minutes.

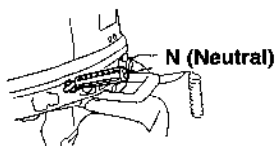

SERVICING YOUR HONDA OUTBOARD MOTOR

Cleaning and Flushing Without the Flush Kit

1. Wash the outside of the outboard motor with clean, fresh water.
2. Remove the propeller.
3. Stand the motor in a suitable container of water. The water level must be at least 2 inches above the anticavitation plate.
4. Start the engine and run slowly for at least 10 minutes.

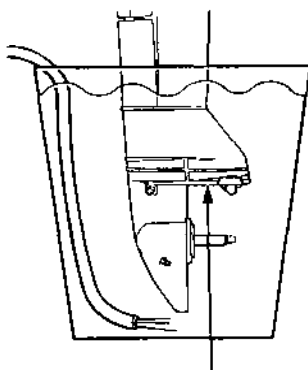

ANTICAVITATION PLATE

SERVICING YOUR HONDA OUTBOARD MOTOR

ENGINE OIL LEVEL CHECK

Check the engine oil level with the engine stopped and the outboard motor in a vertical position.

1. Move the engine cover lock lever down to unlock the cover, and remove the cover.
2. Remove the oil filler cap/dipstick and wipe it clean.

Insert and remove the dipstick without screwing it into the filler neck. Check the oil level shown on the dipstick.

If the oil level is near or below the lower limit mark on the dipstick, fill with the recommended oil to the upper limit mark.

NOTICE

Running the engine with a low oil level can cause engine damage.

3. Install the oil filler cap and tighten it securely.
4. Install the engine cover, and lock it by moving the lever up.

ENGINE COVER LOCK LEVER

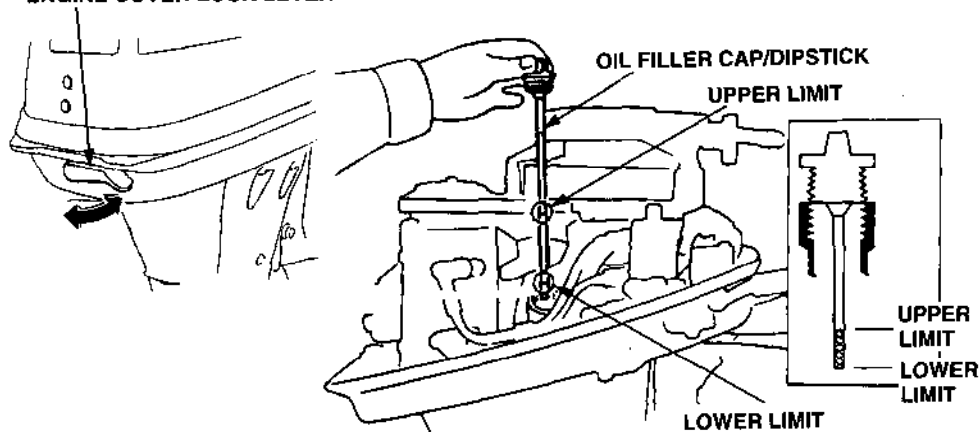

SERVICING YOUR HONDA OUTBOARD MOTOR

ENGINE OIL CHANGE

Drain the used oil while the engine is warm. Warm oil drains quickly and completely.

1. Move the engine cover lock lever (p. 48) down to unlock the cover, and remove the cover.
2. Place a suitable container below the engine oil drain location to catch the used oil, then remove the oil filler cap and the drain plug.
3. Allow the used oil to drain completely, then reinstall the drain plug, and tighten it securely.

NOTICE

Improper disposal of engine oil can be harmful to the environment. If you change your own oil, please dispose of the used oil properly. Put it in a sealed container, and take it to a recycling center. Do not discard it in a trash bin or dump it on the ground.

4. With the outboard motor in a vertical position, fill to the upper limit mark on the dipstick (p. 48) with the recommended oil (p. 50).

Engine oil capacity: 0.85 US qt (0.8 ℓ, 0.7 Imp qt)

5. Install the oil filler cap and tighten it securely.
6. Install the engine cover, and lock it by moving the lever up.

OIL FILLER CAP/DIPSTICK

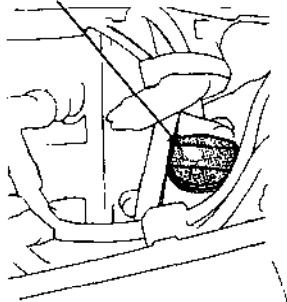

OIL DRAIN PLUG

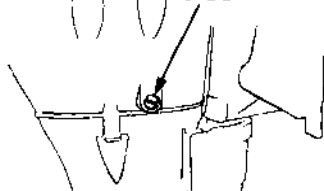

SERVICING YOUR HONDA OUTBOARD MOTOR

ENGINE OIL RECOMMENDATIONS

Oil is a major factor affecting performance and service life. Use 4-stroke automotive detergent oil.

SAE 10W-30 is recommended for general use.

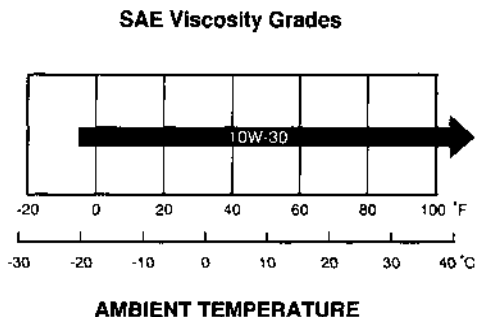

The SAE oil viscosity and service classification are in the API label on the oil container. Honda recommends that you use API SERVICE category SF or SG oil.

SERVICING YOUR HONDA OUTBOARD MOTOR

GEAR OIL LEVEL CHECK

Check the oil level when the motor is in the vertical position. Remove the level plug and see if oil flows out.

If no oil flows out, use a commercially available oil pump or squeeze tube to fill the gear case with the gear oil recommended on page 52. Pump or squeeze fresh oil through the OIL DRAIN plug hole until oil begins flowing out through the OIL LEVEL plug hole.

If there is water in the oil, the water will flow out first when the drain plug is removed, or the oil will be a milky color. If water is detected in the oil, the outboard motor should be inspected by an authorized Honda Outboard Motor dealer.

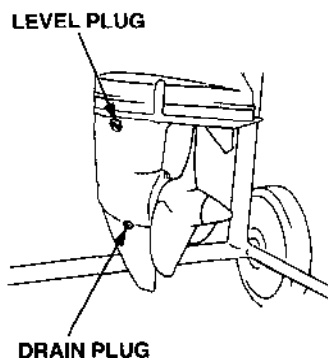

SERVICING YOUR HONDA OUTBOARD MOTOR

GEAR OIL CHANGE

Recommended oil : Marine SAE90 hypoid gear oil
API Service Classification (GL-4 or GL-5)

Oil Capacity : 0.24US qt (0.23 ℓ, 0.20 Imp qt)

Remove the level plug and drain plug and allow the gear oil to thoroughly drain into a suitable container.

Pump or squeeze the recommended gear oil through the OIL DRAIN plug hole until oil starts flowing out through the OIL LEVEL plug hole.

Use new sealing washers. Install the oil lever plug first and then the oil drain plug. Tighten securely.

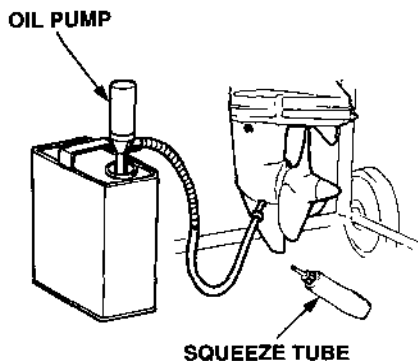
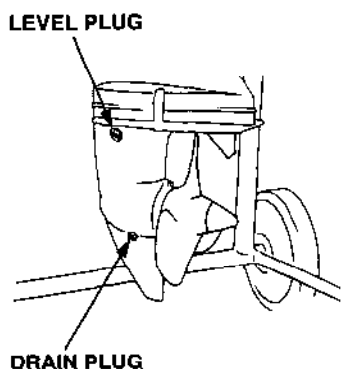

SERVICING YOUR HONDA OUTBOARD MOTOR

LUBRICATION

Apply marine anticorrosion grease to the following areas:

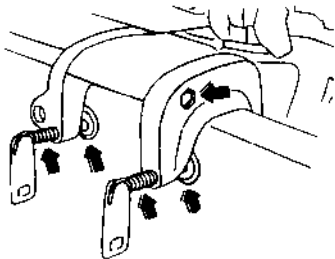

CLAMP SCREWS



**THROTTLE CABLE AND PIVOT
SHIFT SHAFT AND PIVOT**

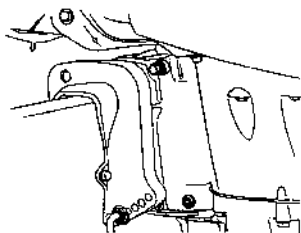

SWIVEL CASE

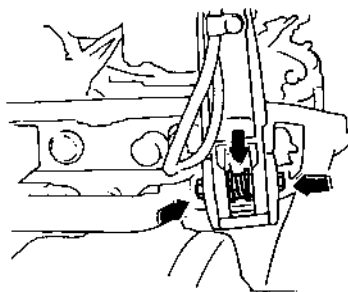

HANDLE PIVOT

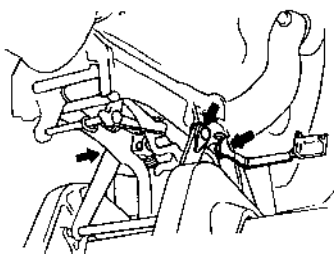

TILT LINKAGE

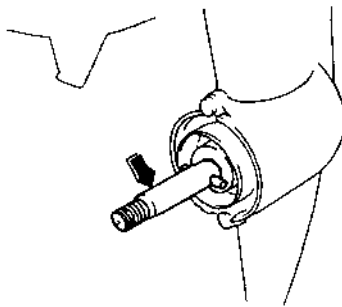

PROPELLER SHAFT

Apply anticorrosion oil to pivot surfaces where grease cannot penetrate.

SERVICING YOUR HONDA OUTBOARD MOTOR

SPARK PLUG SERVICE

Recommended spark plug: DR-5HS (NGK), X16FSR-U (DENSO)

1. Remove the engine cover.
2. Remove the spark plug caps.
3. Use the wrench supplied in the tool kit to remove the spark plugs.
4. Visually inspect the spark plugs. Discard the spark plugs if there is apparent wear, or if the insulators are cracked or chipped. Clean the spark plugs with a wire brush if they are to be reused.
5. Measure the plug gaps with a feeler gauge.
Correct as necessary by carefully bending the side electrode.
The gaps should be:
0.024 – 0.028 in (0.60 – 0.70 mm)

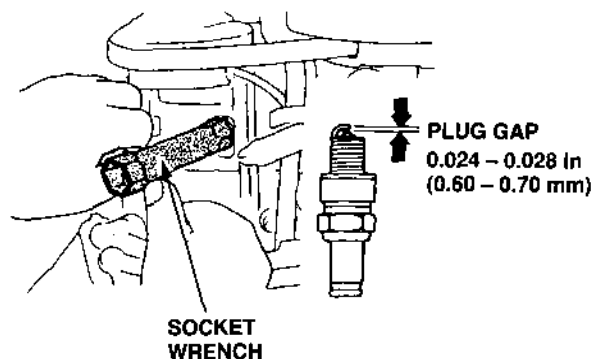

SERVICING YOUR HONDA OUTBOARD MOTOR

6. Check that the spark plug washers are in good condition, and thread the spark plugs in by hand to prevent cross-threading.
7. After the spark plugs are seated, tighten with a spark plug wrench to compress the washers.

If installing a new spark plugs, tighten 1/2 turn after the spark plugs seat to compress the washers. If reinstalling a used spark plugs, tighten 1/8–1/4 turn after the spark plugs seats to compress the washers.

8. Install the engine cover.

NOTICE

- The spark plugs must be securely tightened. Improperly tightened plugs can become very hot and may cause engine damage.
- Use only the recommended spark plugs or equivalent. Spark plugs which have an improper heat range may cause engine damage.

FUEL FILTER REPLACEMENT

The fuel filter is located between the fuel pump and the carburetor. Water or sediment accumulated in the fuel filter can cause loss of power or hard starting. To prevent engine malfunction, replace the fuel filter regularly.

WARNING

Gasoline is highly flammable and explosive.

You can be burned or seriously injured when handling fuel.

- **Keep heat, sparks and flame away.**
- **Handle fuel only outdoors.**
- **Wipe up spills immediately.**

SERVICING YOUR HONDA OUTBOARD MOTOR

1. Disconnect the fuel tank line from the motor.
2. Remove the engine cover, and remove the fuel filter. Before removing the filter, place clamps on the fuel tubes on each side of the filter to prevent fuel leakage.
3. Install the new fuel filter with the arrow mark pointing toward the carburetor. Fuel flow will be impeded if the filter is installed backward.

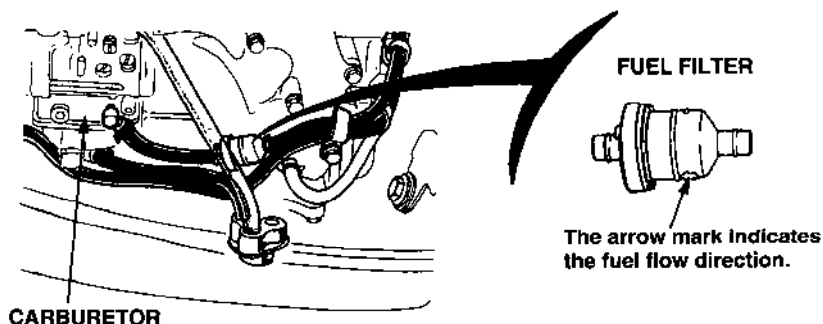

4. If loss of power or hard starting is found to be caused by excessive water or sediment accumulated in the fuel filter, inspect the fuel tank. Clean the fuel tank if necessary.
5. Remove the clamps used to close the fuel tubes. Connect the fuel tank line to the motor. Turn the fuel tank vent knob counterclockwise to the open position, pump the primer bulb, and check for leaks.

SERVICING YOUR HONDA OUTBOARD MOTOR

RECOIL STARTER ROPE INSPECTION

Inspect the recoil starter rope, and replace it if it becomes frayed.

Always keep the tool kit's emergency starter rope onboard in case the recoil starter rope fails.

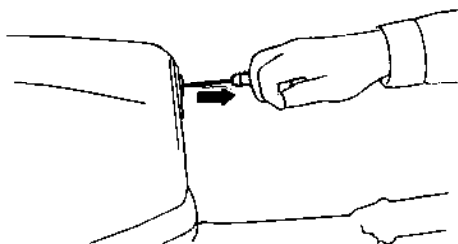

ANODE REPLACEMENT

The anode is a sacrificial material which helps to protect the outboard motor from corrosion.

Replace the anode when it has been reduced to about half its original size, or if it is crumbling.

NOTICE

Painting or coating the anode will defeat its purpose and will lead to rust and corrosion damage to the outboard motor. The anode must be exposed to the water.

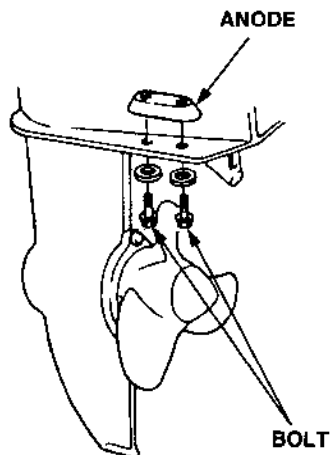

SERVICING YOUR HONDA OUTBOARD MOTOR

SHEAR PIN REPLACEMENT

A shear pin is used to protect the propeller and drive mechanism from damage when the propeller strikes an obstruction.

1. Remove the cotter pin, the propeller cap, and the propeller.
2. Remove the broken shear pin and replace it with a new one.
3. Install the propeller, then install the propeller cap finger tight.
4. Install a new cotter pin, and spread the ends as shown in the illustration.

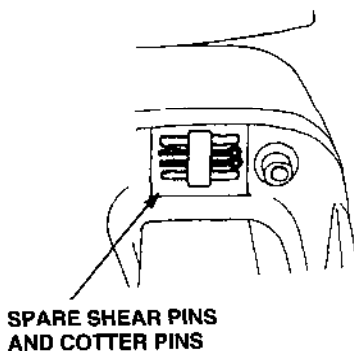
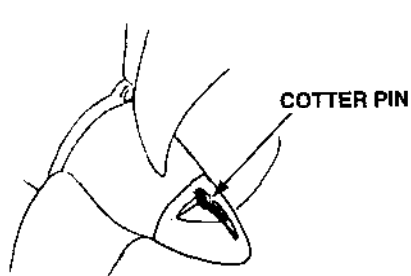
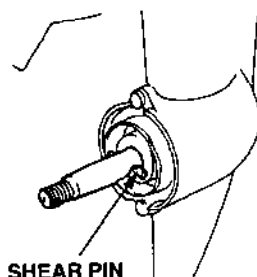
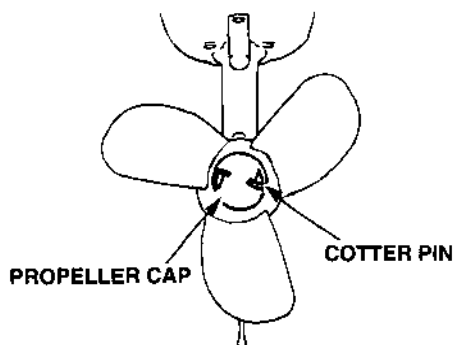

SERVICING YOUR HONDA OUTBOARD MOTOR

ENGINE COVER LOCK ADJUSTMENT

The engine cover should fit tightly to keep the engine compartment dry. If adjustment is needed, reposition the lock hook.

1. Remove the engine cover, and loosen the lock hook bolt with a 10 mm wrench.
2. Reposition the lock hook, and retighten the bolt. Be sure the lockwasher serrations align with the hook serrations when tightening the bolt.
3. Install and lock the engine cover. Check whether the engine cover fits tightly. If necessary, repeat steps 1 and 2 to achieve a tight fit.

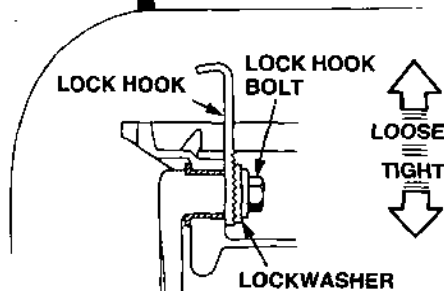
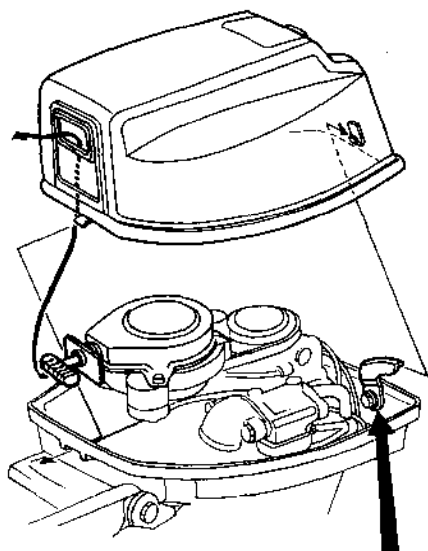

HELPFUL TIPS & SUGGESTIONS

STORING YOUR OUTBOARD MOTOR

Storage Preparation

Proper storage preparation is essential for keeping your outboard motor troublefree and looking good. The following steps will help to keep rust and corrosion from impairing your outboard motor's function and appearance, and will make the engine easier to start when you use the outboard motor again.

Cleaning and Flushing

Wash the outside of the outboard motor with clean, fresh water, and flush the cooling system as described on page 46 or 47.

Disengage the emergency engine stop switch clip from the engine stop switch, and pull the recoil starter rope several times to expel any water remaining in the water pump.

Touch up any damaged paint, and coat areas that may rust with a light film of oil. Lubricate controls with a silicone spray lubricant.

Fuel

Gasoline will oxidize and deteriorate in storage. Old gasoline will cause hard starting, and it leaves gum deposits that clog the fuel system. If the gasoline in your fuel tank and carburetor deteriorates during storage, you may need to have the carburetor and other fuel system components serviced or replaced.

The length of time that gasoline can be left in your fuel tank and carburetor without causing functional problems will vary with such factors as gasoline blend, your storage temperatures, and whether the fuel tank is partially or completely filled. The air in a partially filled fuel tank promotes fuel deterioration. Very warm storage/temperatures accelerate fuel deterioration. Fuel deterioration problems may occur within a few months, or even less if the gasoline was not fresh when you filled the fuel tank.

The *Distributor's Limited Warranty* does not cover fuel system damage or engine performance problems resulting from neglected storage preparation.

HELPFUL TIPS & SUGGESTIONS

1. Disconnect the fuel hose from the outboard motor.
2. With the outboard motor in a vertical position, place an approved gasoline container below the fuel drain outlet, and use a funnel to avoid spilling fuel. Loosen the drain screw to drain fuel from the carburetor.

⚠ WARNING

Gasoline is highly flammable and explosive.

You can be burned or seriously injured when handling fuel.

- **Keep heat, sparks, and flame away.**
- **Handle fuel only outdoors.**
- **Wipe up spills immediately.**

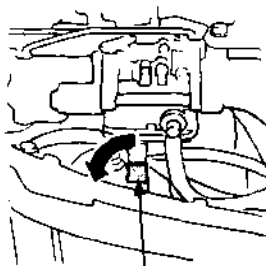

DRAIN SCREW

3. After the fuel has drained from the carburetor, tighten the drain screw securely.
4. Drain the fuel tank into an approved gasoline container, or if you need to store fuel in the portable fuel tank, you can extend fuel storage life by filling the fuel tank with fresh gasoline and adding a fuel stabilizer that is formulated for that purpose. Firmly close the fuel cap vent knob.

Engine Oil

1. Change the engine oil (see page 49).
2. Remove the spark plugs (see page 54).
3. Pour a tablespoon (5 - 10 cc) of clean engine oil into each cylinder.
4. Pull the starter rope several times to distribute the oil in the cylinders.
5. Reinstall the spark plugs.

HELPFUL TIPS & SUGGESTIONS

Storage Precautions

Select a well-ventilated storage area. If possible, avoid storage areas with high humidity.

If your portable fuel tank contains gasoline, store it away from any appliance that operates with a flame, such as a furnace, water heater, or clothes dryer. Also avoid any area with a spark-producing electric motor, or where power tools are operated.

Store the outboard motor either vertically, or horizontally with the tiller handle side down, as shown.

If storing horizontally, be sure to fold the tiller handle, so the outboard motor rests on its case protectors. Be sure all water has drained from the outboard motor before placing it on its side, so no residual water can enter the engine exhaust port.

NOTICE

Any other storage position may cause damage or oil leakage.

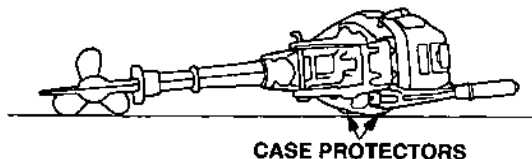
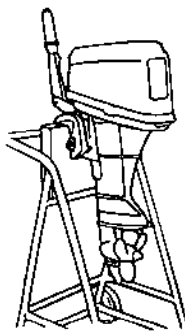

Cover the outboard motor to keep out dust. Do not use sheet plastic as a dust cover. A nonporous cover will trap moisture, promoting rust and corrosion.

HELPFUL TIPS & SUGGESTIONS

Removal From Storage

Check your outboard motor as described in the *BEFORE OPERATION* chapter of this manual.

If the cylinder was coated with oil during storage preparation, the engine may smoke briefly at startup. This is normal.

TRANSPORTING

When trailering a boat with the outboard motor attached, leave the engine in the normal running position, if possible, and tighten the steering friction bolt securely (p. 36).

If there is insufficient road clearance in the normal running position, then tilt the outboard motor, leave the tilt lever in the tilt position, and use a motor support device, such as a transom-saver bar, or remove the outboard motor from the boat.

To transport the outboard motor when removed from the boat, secure it in either the vertical or horizontal position shown on page 62.

To carry, hold the outboard motor by the carrying handle, or hold by the carrying handle and the lug beneath engine cover lock lever as shown below.



NOTICE

Lifting the outboard motor by the engine cover, or using the installed outboard motor as a handle or lever to move the boat, can damage the outboard motor.

TAKING CARE OF UNEXPECTED PROBLEMS

ENGINE WILL NOT START

1. Is the emergency stop switch clip in place?
2. Is the gearshift lever in neutral?
3. Is there fuel in the fuel tank?
4. Is the fuel cap vent knob turned to open?
5. Is the fuel system primed by squeezing the primer bulb?
6. Is fuel reaching the carburetor?

Loosen the carburetor drain screw to see if there is fuel in the carburetor float bowl.

⚠ WARNING

If any fuel is spilled, make sure the area is dry before testing the spark plug or starting the engine. Spilled fuel or fuel vapor may ignite.

7. Are the spark plugs firing?
 - a. Remove and inspect the spark plugs. Clean and dry the plugs, and check the electrode gaps (p. 54).
 - b. Install the spark plugs in their caps, and ground the side electrode to any engine ground away from the spark plug holes.
 - c. Pull the recoil starter briskly, and see if the plug sparks.
 - d. If the spark plugs are OK, reinstall them, and try to start the engine.

Engine overheats:

1. Is the water intake screen clogged?
2. Is the thermostat faulty?

TAKING CARE OF UNEXPECTED PROBLEMS

BATTERY DOES NOT CHARGE

The battery-charging circuit is protected by a 5-ampere fuse.

If the fuse burns out, running the engine will not charge the battery.

Fuse Replacement

1. With the engine stopped, remove the engine cover.
2. Pull the rubber cover off the end of the fuse holder, and unscrew the fuse holder cap.
3. Remove and inspect the fuse. If the fuse is burnt out, install a replacement 5 A fuse.

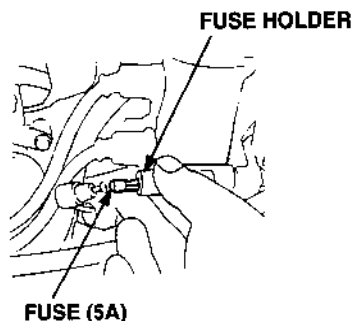

NOTICE

Never use a fuse with a rating greater than 5 amperes. Serious damage to the electrical system could result.

4. Reinstall the fuse holder and engine cover.

Before further operation, try to determine and correct the electrical problem that caused the fuse to burn out. An uncorrected electrical problem may cause the fuse to burn out again.

TAKING CARE OF UNEXPECTED PROBLEMS

SUBMERGED MOTOR

A submerged motor must be serviced immediately after it is recovered from the water in order to minimize corrosion.

If there is a Honda marine dealership nearby, take the motor immediately to the dealer. If you are far from a dealership, proceed as follows:

1. Remove the engine cover, and rinse the motor with fresh water to remove salt water, sand, mud, etc.
2. Loosen the carburetor drain screw (p. 61), drain the contents of the carburetor into a suitable container, then tighten the drain screw.
3. Change the engine oil (p. 49). If there was water in the engine crankcase, or the used engine oil showed signs of water contamination, then a second engine oil change should be performed after running the engine for 1/2 hour.
4. Remove the spark plugs. Disengage the emergency engine stop switch clip from the engine stop switch and pull the recoil starter several times to completely expel water from the cylinders.

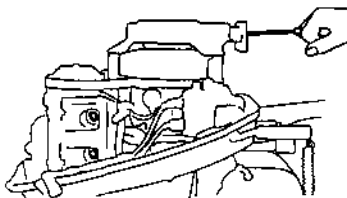

NOTICE

- When cranking the engine with an open ignition circuit (spark plugs removed from the ignition circuit), disengage the emergency engine stop switch clip from the engine stop switch to prevent electrical damage to the ignition system.
- If the engine was running when it submerged, there may be mechanical damage, such as bent connecting rods. If the engine binds when cranked, do not attempt to run the engine until it has been repaired.

TAKING CARE OF UNEXPECTED PROBLEMS

5. Pour a teaspoon of engine oil into each spark plug hole, then pull the recoil starter several times to lubricate the inside of the cylinders. Reinstall the spark plugs and engage the emergency engine stop switch clip with the engine stop switch.

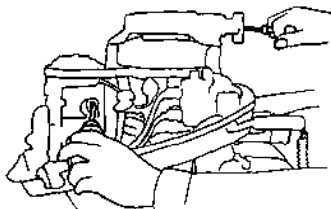

6. Attempt to start the engine.
 - If the engine fails to start, remove the spark plugs, clean and dry the electrodes, then reinstall the spark plugs and attempt to start the engine again.
 - If the engine starts, and no mechanical damage is evident, continue to run the engine for 1/2 hour or longer (be sure the water level is at least 2 inches above the anticavitation plate).
7. As soon as possible, take the motor to a Honda marine dealer for inspection and service.

TECHNICAL & CONSUMER INFORMATION

TECHNICAL INFORMATION

Serial Number Locations

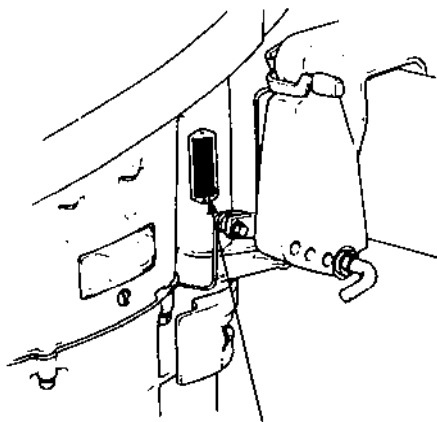
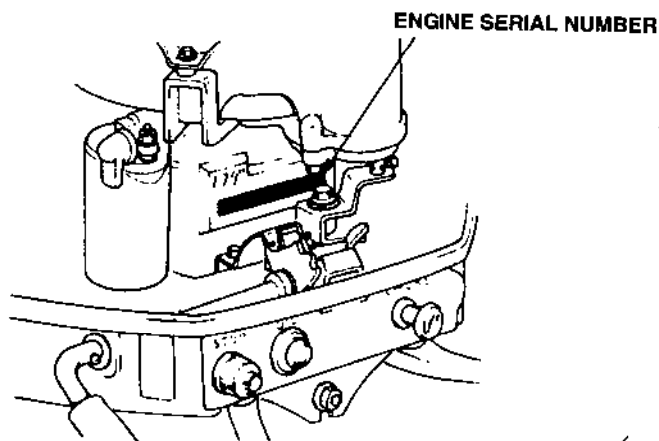

Record the engine and frame serial numbers in the space below. You will need these serial numbers when ordering parts, and when making technical or warranty inquiries (see page 77).

Engine serial number: _____

Frame serial number: _____

TECHNICAL & CONSUMER INFORMATION

Carburetor Modification for High Altitude Operation

At high altitude, the standard carburetor air-fuel mixture will be too rich. Performance will decrease, and fuel consumption will increase. A very rich mixture will also foul the spark plug and cause hard starting.

High altitude performance can be improved by specific modifications to the carburetor. If you always operate your engine at altitudes above 5,000 feet (1,500 meters), have an authorized Honda marine dealer perform this carburetor modification.

Even with carburetor modification, engine horsepower will decrease about 3.5 % for each 1,000-foot (300-meter) increase in altitude. The effect of altitude on horsepower will be greater than this if no carburetor modification is made.

NOTICE

When the carburetor has been modified for high altitude operation, the air-fuel mixture will be too lean for low altitude use. Operation at altitudes below 5,000 feet (1,500 meters) with a modified carburetor may cause the engine to overheat and result in serious engine damage. For use at low altitudes, have an authorized Honda marine dealer return the carburetor to original factory specifications.

TECHNICAL & CONSUMER INFORMATION

Oxygenated Fuels

Some conventional gasolines are being blended with alcohol or an ether compound. These gasolines are collectively referred to as oxygenated fuels. To meet clean air standards, some areas of the United States and Canada use oxygenated fuels to help reduce emissions.

If you use an oxygenated fuel, be sure it is unleaded and meets the minimum octane rating requirement.

Before using an oxygenated fuel, try to confirm the fuel's contents. Some states/provinces require this information to be posted on the pump.

The following are the EPA-approved percentages of oxygenates:

ETHANOL ——— (ethyl or grain alcohol) 10% by volume
You may use gasoline containing up to 10% ethanol by volume. Gasoline containing ethanol may be marketed under the name "Gasohol".

MTBE ————— (Methyl Tertiary Butyl Ether) 15% by volume
You may use gasoline containing up to 15% MTBE by volume.

METHANOL — (methyl or wood alcohol) 5% by volume
You may use gasoline containing up to 5% methanol by volume, as long as it also contains cosolvents and corrosion inhibitors to protect the fuel system. Gasoline containing more than 5% methanol by volume may cause starting and/or performance problems. It may also damage metal, rubber, and plastic parts of your fuel system.

If you notice any undesirable operating symptoms, try another service station, or switch to another brand of gasoline.

Fuel system damage or performance problems resulting from the use of an oxygenated fuel containing more than the percentages of oxygenates mentioned above are not covered under warranty.

Emission Control System Information

Source of Emissions

The combustion process produces carbon monoxide, oxides of nitrogen, and hydrocarbons. Control of hydrocarbons and oxides of nitrogen is very important because, under certain conditions, they react to form photochemical smog when subjected to sunlight. Carbon monoxide does not react in the same way, but it is toxic.

Honda utilizes lean carburetor settings and other systems to reduce the emissions of carbon monoxide oxides of nitrogen, and hydrocarbons.

The U.S. Clean Air Act

EPA regulations require all manufacturers to furnish written instructions describing the operation and maintenance of emission control systems.

The following instructions and procedures must be followed in order to keep the emissions from your Honda engine within the emission standards.

Tampering and Altering

Tampering with or altering the emission control system may increase emissions beyond the legal limit. Among those acts that constitute tampering are:

- Removal or alteration of any part of the intake, fuel, or exhaust systems.
- Alterations that would cause the engine to operate outside its design parameters.

TECHNICAL & CONSUMER INFORMATION

Problems That May Affect Emissions

If you are aware of any of the following symptoms, have your engine inspected and repaired by your servicing dealer.

- Hard starting or stalling after starting.
- Rough idle.
- Misfiring or backfiring under load.
- Afterburning (backfiring).
- Black exhaust smoke or high fuel consumption.

Replacement Parts

The emission control systems on your Honda engine were designed, built, and certified to conform with EPA emission regulations. We recommend the use of genuine Honda parts whenever you have maintenance done. These original-design replacement parts are manufactured to the same standards as the original parts, so you can be confident of their performance. The use of replacement parts that are not of the original design and quality may impair the effectiveness of your emission control system.

A manufacturer of an aftermarket part assumes the responsibility that the part will not adversely affect emission performance. The manufacturer or rebuilder of the part must certify that use of the part will not result in a failure of the engine to comply with emission regulations.

Maintenance

Follow the maintenance schedule on page 43. Remember that this schedule is based on the assumption that your machine will be used for its designed purpose. Sustained high-load or high-temperature operation, will require more frequent service.

TECHNICAL & CONSUMER INFORMATION

Specifications

Model		BF8A			
Description code		BZBC			
Rated power		6.3 kW (8.4 HP)			
Full throttle range		4,950 — 5,500 rpm			
Engine type		4-stroke OHC in-line twin cylinder			
Displacement		12.0 cu-in (197 cm ³)			
Spark plug gap		0.024 — 0.028 in (0.60 — 0.70 mm)			
Starter system		Recoil starter			
Ignition system		C.D.I.			
Lubrication system		Trochoid pump pressure lubrication			
Specified oil		Engine: API standard (SF or SG) SAE 10W-30 Gear case: Marine SAE 90 hypoid gear oil API Service Classification (GL-4 or GL-5)			
Oil capacity		Engine: 0.85 US qt (0.80 ℓ, 0.70 Imp qt) Gear case: 0.24 US qt (0.23 ℓ, 0.20 Imp qt)			
D.C. output		12V — 5A			
Cooling system		Water cooling with thermostat (volumetric pump)			
Exhaust system		Underwater exhaust			
Spark plug		DR-5HS (NGK), X16FSR-U (DENSO)			
Fuel pump		Diaphragm type fuel pump			
Fuel		Automotive gasoline (86 pump octane)			
Tank capacity		3.0 US gal (12 ℓ, 2.6 Imp gal)			
Steering equipment		Tiller handle			
Tilt angle		3-stage adjustment (30°, 45° and 70°)			
Angle of rotation		40° (both sides)			
Dimensions		S Model	L Model	X Model	
		Length	20.7 in (525 mm)	20.7 in (525 mm)	20.7 in (525 mm)
		Height	39.8 in (1,010 mm)	45.7 in (1,160 mm)	48.8 in (1,240 mm)
		Width	12.4 in (315 mm)	12.4 in (315 mm)	12.4 in (315 mm)
Outboard motor transom height		S Model	L Model	X Model	
		16.5 in (420 mm)	22.4 in (570 mm)	25.5 in (648 mm)	
Standard propeller (No. of blades-diameter x pitch)		9-1/2 x 8-5/8 in (3-240 x 220 mm)			
Gear change		Forward-Neutral Reverse (dog type)			
Dry weight		S Model	77.2 lbs. (35.0 kg)		
		L Model	79.4 lbs. (36.0 kg)		
		X Model	81.6 lbs. (37.0 kg)		

Honda outboards are power rated in accordance with NMMA procedures and using the ICOMIA standard 28/23.

TECHNICAL & CONSUMER INFORMATION

Tuneup

Spark plug gap	0.024-0.028 in (0.60-0.70 mm)	See page 54.
Idle speed	1,100 ± 50 rpm	See shop manual.
Valve clearance (cold)	Intake: 0.12 ± 0.02 mm Exhaust: 0.15 ± 0.02 mm	See shop manual.
Other specifications	No other adjustments needed.	

TECHNICAL & CONSUMER INFORMATION

WIRING DIAGRAMS

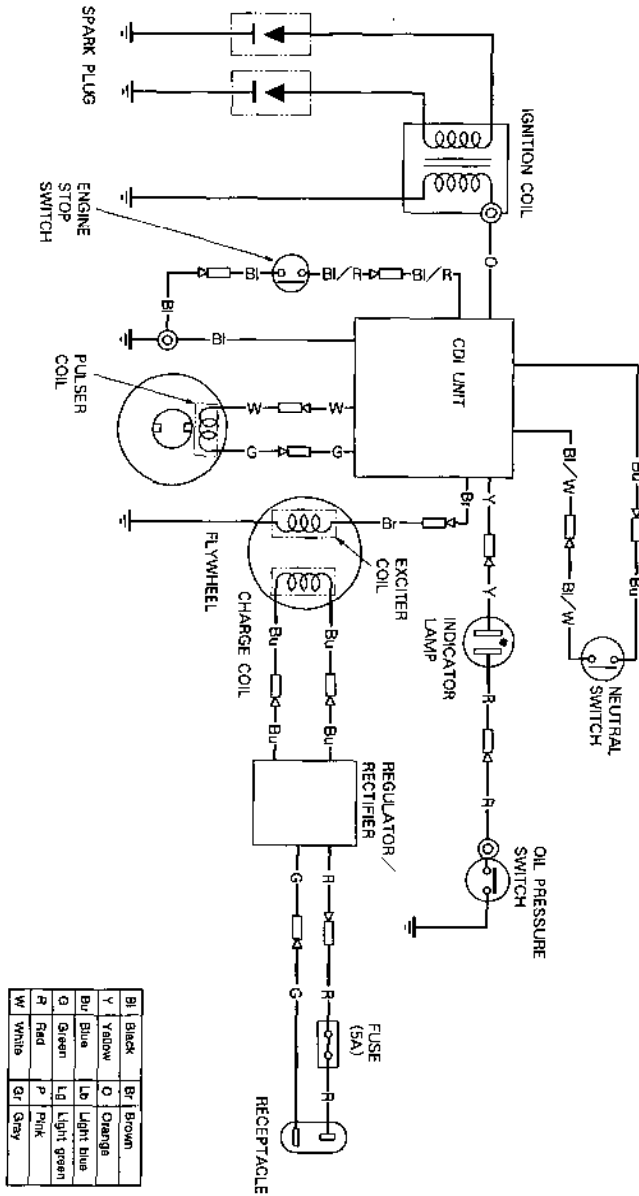

TECHNICAL & CONSUMER INFORMATION

CONSUMER INFORMATION

Honda Publications

These publications will give you additional information for maintaining and repairing your outboard motor. You may order them from your Honda marine dealer.

Shop Manual

This manual covers complete maintenance and overhaul procedures. It is intended to be used by a skilled technician.

Parts Catalog

This manual provides complete, illustrated parts lists.

TECHNICAL & CONSUMER INFORMATION

Warranty Service Information

Honda marine dealership personnel are trained professionals. They should be able to answer any question you may have. If you encounter a problem that your dealer does not solve to your satisfaction, please discuss it with the dealership's management. The Service Manager or General Manager can help. Almost all problems are solved in this way.

If you are dissatisfied with the decision made by the dealership's management, contact the Honda Marine Customer Relations Office. You can write:

American Honda Motor Co., Inc.
Marine Division
Customer Relations Office
4900 Marconi Drive
Alpharetta, Georgia 30005-8847

Or telephone: (770) 497-6400

When you write or call, please give us this information:

- Model and serial number (see page 68)
- Name of the dealer who sold the outboard motor to you
- Name and address of the dealer who services your outboard motor
- Date of purchase
- Your name, address, and telephone number
- A detailed description of the problem

INDEX

A

Anode	18
ANODE REPLACEMENT	57

B

BATTERY CONNECTIONS	22
BATTERY DOES NOT CHARGE	65
Fuse Replacement	65
BEFORE OPERATION	25
ARE YOU READY TO GET UNDER WAY?	25
Knowledge	25
Safety Apparel	25
IS YOUR OUTBOARD MOTOR READY TO GO?	25
Maintenance Inspection	26
Safety Inspection	26
BREAK-IN PROCEDURE	27

C

Choke Knob	12
CONTENTS	3
CONTROLS & FEATURES	10
COMPONENT & CONTROL LOCATIONS	10
CONTROLS	12
Choke Knob	12
Engine Cover Lock Lever	16
Engine Stop Switch	12
Fuel Cap Vent Knob	17
Fuel Priming Bulb	17
Gearshift Lever	14
Recoil Starter Grip	14
Steering Friction Bolt	15
Throttle Friction Knob	13
Throttle Grip	13
Tilt Lever	15
Transom Angle Adjusting Rod	16
FEATURES	17
Anode	18
Fuel Gauge	17
Oil Pressure Indicator Light	17
Water Check Tube	17
CONSUMER INFORMATION	76
COOLING SYSTEM CLEANING AND FLUSHING	46
CRUISING	37
Carbon Monoxide Hazard	8

E

EMERGENCY PROCEDURES	23
EMERGENCY STARTING	33
ENGINE COVER LOCK ADJUSTMENT	59
ENGINE OIL CHANGE	49

ENGINE OIL RECOMMENDATIONS	50
ENGINE WILL NOT START	64
Emergency Engine Stopping	34
Emission Control System Information	71
Engine Cover Lock Lever	16
Engine Stop Switch	12

F

FEATURES	17
Anode	18
Fuel Gauge	17
Oil Pressure Indicator Light	17
Water Check Tube	17
FUEL FILTER REPLACEMENT	55
FUEL RECOMMENDATIONS	45
Fuel Cap Vent Knob	17
Fuel Gauge	17
Fuel Hose Connections	28
Fuel Priming	28
Fuel Priming Bulb	17
Fuel Tank Placement	27
Fuse Replacement	65

G

GEAR OIL CHANGE	52
GEAR OIL LEVEL CHECK	51
GEAR SHIFTING	35
Gearshift Lever	14

H

HELPFUL TIPS AND SUGGESTIONS	60
STORING YOUR OUTBOARD MOTOR	60
Removal From Storage	63
Storage Precautions	62
Storage Preparation	60
Honda Publications	76

I

INTRODUCTION	1
IMPORTANT SAFETY INFORMATION	7
INDEX	78
INSTALLATION	19
BATTERY CONNECTIONS	22
Battery Installation	23
Connections to the Battery	24
INSTALLATION HEIGHT	19
INSTALLATION POSITION	19
MOTOR ANGLE ADJUSTMENT	21
MOTOR ANGLE FOR CRUISING	20
OUTBOARD MOTOR ATTACHMENT	20

INDEX

L

LUBRICATION	53
-------------------	----

M

Maintenance Inspection	26
MAINTENANCE SAFETY	41
Safety Precautions	41
MAINTENANCE SCHEDULE	43
MOTOR ANGLE ADJUSTMENT	21
MOTOR ANGLE FOR CRUISING	20

N

Normal Engine Stopping	34
------------------------------	----

O

Oil Pressure Indicator Light	17
OPERATION	27
BREAK-IN PROCEDURE	27
CRUISING	37
EMERGENCY STARTING	33
GEAR SHIFTING	35
PORTABLE FUEL TANK PLACEMENT AND CONNECTIONS	27
Fuel Hose Connections	28
Fuel Priming	28
Fuel Tank Placement	27
SAFE OPERATING PRECAUTIONS	27
STARTING THE ENGINE	29
STEERING	36
STOPPING THE ENGINE	34
Emergency Engine Stopping	34
Normal Engine Stopping	34
TILTING THE OUTBOARD MOTOR	38
OUTBOARD MOTOR ATTACHMENT	20
Oxygenerated Fuels	70

P

PORTABLE FUEL TANK PLACEMENT AND CONNECTIONS	27
Fuel Hose Connections	28
Fuel Priming	28
Fuel Tank Placement	27

Q

QUICK REFERENCE INFORMATION	Inside back cover
-----------------------------------	-------------------

R

Recoil Starter Grip	14
RECOIL STARTER ROPE INSPECTION	57
REFUELING	44
Removal From Storage	63

S	
SAFE OPERATING PRECAUTIONS	27
SAFETY, A FEW WORDS ABOUT	2
Safety Inspection	26
SAFETY, OUTBOARD MOTOR	2
IMPORTANT SAFETY INFORMATION	7
Carbon Monoxide Hazard	8
Operating Responsibility	7
Refuel With Care	8
SAFETY LABEL LOCATIONS	9
SHEAR PIN REPLACEMENT	58
SPARK PLUG SERVICE	54
STARTING THE ENGINE	29
STEERING	36
STOPPING THE ENGINE	34
STORING YOUR OUTBOARD MOTOR	60
Serial Number Locations	68
Specifications	73
Steering Friction Bolt	15
Storage Precautions	62
Storage Preparation	60
SUBMERGED MOTOR	66
T	
TAKING CARE OF UNEXPECTED PROBLEMS	64
TECHNICAL & CONSUMER INFORMATION	68
TECHNICAL INFORMATION	68
THE IMPORTANCE OF MAINTENANCE	40
Throttle Friction Knob	13
Throttle Grip	13
TILTING THE OUTBOARD MOTOR	38
Tilt Lever	15
TOOL KIT AND SPARE PARTS	42
TRANSPORTING	63
Transom Angle Adjusting Rod	16
W	
Warranty Service Information	77
Water Check Tube	17
WIRING DIAGRAMS	75

MEMO

MEMO

MEMO

QUICK REFERENCE INFORMATION

Fuel	Type	Unleaded gasoline with a pump octane rating of 86 or higher (page 45)
	Capacity	3.2 US gal (12.0 ℓ)
Engine Oil	Type	SAE 10W-30, API SF or SG, for general use (page 50)
	Capacity	0.85 US qt (0.8 ℓ)
Gear Oil	Type	Marine SAE 90 hypoid, API GL-4 or GL-5
	Capacity	0.24 US qt (0.23 ℓ)
Spark Plug	Type	DR-5HS (NGK), X16FSR-U (DENSO)
	Gap	0.024–0.028 in (0.60–0.70 mm) (page 54)
Carburetor	Idle speed	1,100 ± 50 rpm
Maintenance	Before each use	Check engine oil level (page 48). Check fuel hose (page 26). Check propeller and cotter pin (page 26). Check anode (page 26)
	First 20 hours	Change engine oil (page 49). Change gear oil (page 52). Check carburetor linkage. Check/adjust valve clearance. Grease lubrication points (page 53).
	Subsequent	Refer to the maintenance schedule on page 43.

HONDA

31881731
00X31-881-7310



Printed on
Recycled Paper



POM50316A

Kinko's 70.2002.04

PRINTED IN U.S.A.