

HONDA
MARINE

BF8D·BF9.9D·BFP8D·BFP9.9D
BF15D·BF20D·BFP15D
Owner's Manual

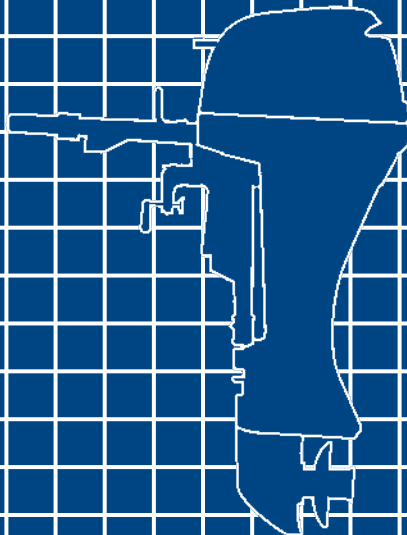

Includes US and Canadian Models

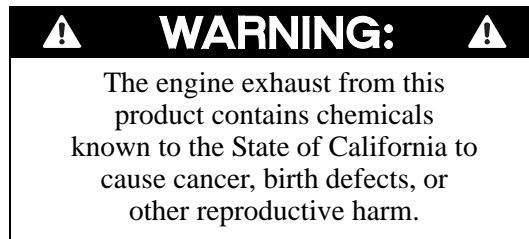

Keep this Owner's Manual handy, so you can refer to it at any time. This Owner's Manual is considered a permanent part of the outboard motor and should remain with the outboard motor if resold.

© 2013 Honda Motor Co., Ltd. – All Rights Reserved

The information and specifications included in this publication were in effect at the time of approval for printing. Honda Motor Co., Ltd. reserves the right, however, to discontinue or change specifications or design at any time without notice and without incurring any obligation whatever. No part of this publication may be reproduced without written permission.

INTRODUCTION

Congratulations on your selection of a Honda outboard motor. We are certain you will be pleased with your purchase of one of the finest outboard motors on the market.

We want to help you get the best results from your new outboard motor and to operate it safely. This manual contains information on how to do that; please read it carefully.

As you read this manual you will find information preceded by a

NOTICE symbol. That information is intended to help you avoid damage to your outboard motor, other property, or the environment.

We suggest you read the warranty policy to fully understand its coverage and your responsibilities of ownership.

When your outboard motor needs scheduled maintenance, keep in mind that your Honda Marine dealer is specially trained in servicing Honda outboard motors. Your Honda Marine dealer is dedicated to your satisfaction and will be pleased to answer your questions and concerns.

Best Wishes,
Honda Motor Co., Ltd.

INTRODUCTION

A FEW WORDS ABOUT SAFETY

Your safety and the safety of others are very important. And using this outboard motor safely is an important responsibility.

To help you make informed decisions about safety, we have provided operating procedures and other information on labels and in this manual. This information alerts you to potential hazards that could hurt you or others.

Of course, it is not practical or possible to warn you about all the hazards associated with operating or maintaining an outboard motor. You must use your own good judgment.

You will find important safety information in a variety of forms, including:

- **Safety Labels** – on the outboard motor.
- **Safety Messages** – preceded by a safety alert symbol  and one of three signal words, DANGER, WARNING, or CAUTION.

These signal words mean:

 **DANGER**

You **WILL** be **KILLED** or **SERIOUSLY HURT** if you don't follow instructions.

 **WARNING**

You **CAN** be **KILLED** or **SERIOUSLY HURT** if you don't follow instructions.

 **CAUTION**

You **CAN** be **HURT** if you don't follow instructions.

- **Safety Headings** – such as *IMPORTANT SAFETY INFORMATION*.
- **Safety Section** – such as *OUTBOARD MOTOR SAFETY*.
- **Instructions** – how to use this outboard motor correctly and safely.

This entire book is filled with important safety information – please read it carefully.

CONTENTS

OUTBOARD MOTOR SAFETY	7	Gearshift/Throttle Control Lever	28
IMPORTANT SAFETY INFORMATION	7	Power Tilt Switch (T type)	29
SAFETY LABEL LOCATIONS	9	Manual Relief Valve (T type)	29
CONTROLS AND FEATURES	13	Tilt Lock Lever (G and T types)	30
CONTROL AND FEATURE		Common Controls	
IDENTIFICATION CODES	13	Engine Cover Latch	30
COMPONENT AND CONTROL LOCATIONS ...	17	Transom Angle Adjusting Rod	30
CONTROLS	22	Tilt Lever (manual tilt type)	31
H Type (tiller handle)		INSTRUMENTS	32
Emergency Stop Switch Clip and Emergency		Fuel Gauge	32
Stop Switch	22	Tachometer [optional equipment (R Type)]	32
Choke Knob (manual choke type)	22	INDICATORS	33
Throttle Grip	23	Oil Pressure Indicator (R type) (H type)	33
Throttle Friction Adjuster	23	Overheat Indicator	33
Gearshift Lever	23	R type	33
Starter Grip	24	H type	34
Electric Starter Button		Cooling System Indicator	34
(types equipped with electric starter)	24	OTHER FEATURES	35
Steering Friction Lever	24	Rev Limiter	35
Power Tilt Switch (T type)	25	Automatic Choke	
R Type (remote control)		(types equipped with electric starter)	35
Ignition Switch	26	Anodes	35
Emergency Stop Switch Clip and Emergency		Portable Fuel Tank	36
Stop Switch	26	Fuel Filler Cap Vent Knob	36
Fast Idle Lever	27	Fuel Priming Bulb	36

CONTENTS

INSTALLATION	37	STOPPING THE ENGINE	57
POWER REQUIREMENTS	37	Emergency Engine Stopping	57
BOAT TRANSOM REQUIREMENTS	37	Normal Engine Stopping	57
INSTALLATION POSITION	37	GEARSHIFT AND	
ATTACHMENT	38	THROTTLE OPERATION	59
TRANSOM ANGLE ADJUSTMENT	39	H Type (tiller handle)	59
BATTERY CONNECTIONS	40	R Type (remote control)	60
BEFORE OPERATION	43	STEERING	61
ARE YOU READY TO GET UNDERWAY?	43	H Type (tiller handle)	61
IS YOUR OUTBOARD MOTOR		R Type (remote control)	61
READY TO GO?	43	CRUISING	62
OPERATION	45	SHALLOW WATER OPERATION	64
SAFE OPERATING PRECAUTIONS	45	MOORING, BEACHING, LAUNCHING	67
BREAK-IN PROCEDURE	45	SERVICING YOUR OUTBOARD MOTOR	69
TRANSOM ANGLE ADJUSTMENT	46	THE IMPORTANCE OF MAINTENANCE	69
PORTABLE FUEL TANK	47	MAINTENANCE SAFETY	70
FUEL HOSE CONNECTIONS	48	TOOL KIT AND EMERGENCY STARTER	
FUEL PRIMING	48	ROPE	71
INFREQUENT OR OCCASIONAL USE	49	MAINTENANCE SCHEDULE	72
STARTING THE ENGINE	49	MANUAL RELIEF VALVE (T type)	74
H Type (tiller handle)	49	ENGINE COVER REMOVAL AND	
R Type (remote control)	52	INSTALLATION	74
EMERGENCY STARTING	54	Engine Oil Level Check	75
		Engine Oil Change	76
		Oil Filter Change	78

CONTENTS

Engine Oil Recommendations	79	TRANSPORTING	99
Gear Case Oil Level Check	79	WITH OUTBOARD MOTOR INSTALLED	
Gear Case Oil Change	80	ON BOAT	99
Lubrication Points	82	WITH OUTBOARD MOTOR REMOVED	
Spark Plug Service	83	FROM BOAT	99
REFUELING	84		
FUEL RECOMMENDATIONS	86	TAKING CARE OF UNEXPECTED PROBLEMS ...	100
Fuel Filter Inspection and Replacement	87	ELECTRIC STARTER WILL NOT OPERATE ..	100
Portable Fuel Tank and Tank Filter Cleaning	89	ENGINE WILL NOT START	101
Recoil Starter Rope Inspection	90	HARD STARTING OR STALLS AFTER	
Anode Replacement	90	STARTING	103
Choke Knob Friction (manual choke type)	91	ENGINE OVERHEATS	104
Propeller Replacement	91	BATTERY WILL NOT CHARGE AND	
		ELECTRIC STARTER WILL NOT	
CLEANING AND FLUSHING	93	OPERATE	105
Cleaning and Flushing	93	Fuse Replacement	105
STORAGE	95	OIL PRESSURE INDICATOR GOES OFF AND	
Fuel	95	ENGINE SPEED IS LIMITED	106
Engine Oil	97	OVERHEAT AND ENGINE SPEED IS	
STORAGE PRECAUTIONS	97	LIMITED	107
REMOVAL FROM STORAGE	98	SUBMERGED OUTBOARD MOTOR	109

CONTENTS

TECHNICAL INFORMATION	111
Serial Number Locations	111
Carburetor Modification for High Altitude Operation	112
Emission Control System Information	113
Star Label	115
Specifications	117
CONSUMER INFORMATION	125
Honda Publications	125
Customer Service Information	125
Warranty Statements	128
Distributor's Limited Warranty	128
Emission Control System Warranty	133
Distributor's Warranty	137
INDEX	140

This Owner's Manual uses the following Type names when describing an operation unique to a particular Type:

Tiller handle type: H type
Remote control type: R type
Power tilt type: T type
Gas assist tilt type: G type

Check the type of your outboard motor and read this Owner's Manual thoroughly before operation. Text with no Type indication refers to information/procedures common to all Types.

OUTBOARD MOTOR SAFETY

IMPORTANT SAFETY INFORMATION

The Honda BF8D/BFP8D/BF9.9D/BFP9.9D/BF15D/BFP15D and BF20D outboard motors are designed for use with boats that have a suitable manufacturer's power recommendation. Other uses can result in injury to the operator or damage to the outboard motor and other property.

Most injuries or property damage can be prevented if you follow all instructions in this manual and on the outboard motor. The most common hazards are discussed in this chapter, along with the best way to protect yourself and others.

Operator Responsibility

- It is the operator's responsibility to provide the necessary safeguards to protect people and property. Know how to stop the engine quickly in case of emergency. Understand the use of all controls.
 - Stop the engine immediately if anyone falls overboard, and do not run the engine while the boat is near anyone in the water.
 - Always stop the engine if you must leave the controls for any reason.
- Attach the emergency stop switch lanyard securely to the operator.
 - Always wear a PFD (Personal Flotation Device) while on the boat.
 - Familiarize yourself with all laws and regulations relating to boating and the use of outboard motors.
 - Be sure that anyone who operates the outboard motor receives proper instruction.
 - Be sure the outboard motor is properly mounted on the boat.
 - Do not remove the engine cover while the engine is running.

OUTBOARD MOTOR SAFETY

Refuel With Care

- Gasoline is extremely flammable, and gasoline vapor can explode. Refuel outdoors, in a well-ventilated area, with the engine stopped. Never smoke near gasoline, and keep other flames and sparks away.
- Remove any portable fuel tank from the boat for refueling. Keep the portable fuel tank away from the battery or other potential spark sources.
- Refuel carefully to avoid spilling fuel. Avoid overfilling the fuel tank.
- After refueling, tighten the filler cap securely. If any fuel is spilled, make sure the area is dry before starting the engine.

Carbon Monoxide Hazard

Exhaust contains poisonous carbon monoxide, a colorless, odorless gas. Breathing carbon monoxide can cause loss of consciousness and may lead to death.

If you run the engine in an area that is confined, or even partly enclosed, the air you breathe could contain a dangerous amount of exhaust gas.

Never run your outboard inside a garage or other enclosure.

OUTBOARD MOTOR SAFETY

SAFETY LABEL LOCATIONS

US, Puerto Rico, and US Virgin Islands Types

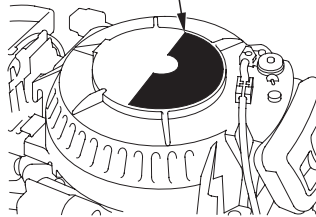
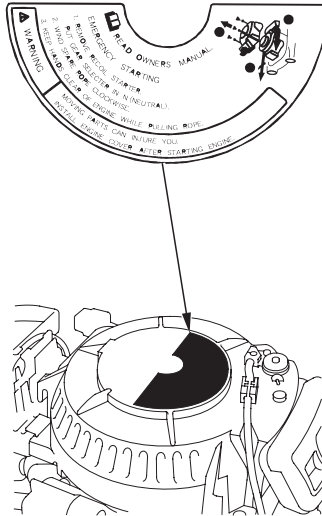
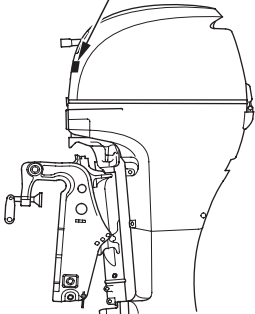
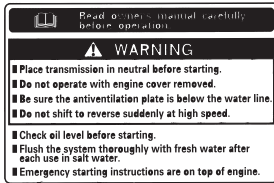

GASOLINE FLAMMABLE DANGER

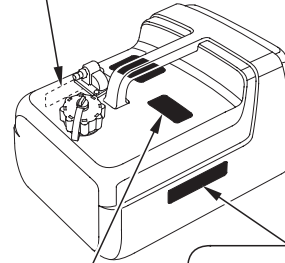

GASOLINE FLAMMABLE DANGER

CAUTION

KEEP TOTALLY CLOSED WHEN NOT IN USE. KEEP AWAY FROM HEAT, SPARKS, AND OPEN FLAME. SECURE ABOVE DECK IN WELL VENTILATED AREA. DO NOT USE FOR LONG TERM FUEL STORAGE.

DANGER

HARMFUL OR FATAL IF SWALLOWED. KEEP OUT OF REACH OF CHILDREN. IF SWALLOWED, DO NOT INDUCE VOMITING. CALL A PHYSICIAN IMMEDIATELY.

The labels shown here contain important safety information. Please read them carefully. These labels are considered permanent parts of your outboard motor. If a label comes off or becomes hard to read, contact an authorized Honda Marine dealer for a replacement.

OUTBOARD MOTOR SAFETY

Canadian Types [Equipped type]

READ OWNER'S MANUAL



Ⓢ DO NOT SHIFT TO REVERSE SUDDENLY AT HIGH SPEED.
 Ⓢ BEI HOHER FAHRGESCHWINDIGKEIT AUF KEINEN FALL PLÖTZLICH DEN RÜCKWÄRTSGANG EINLEGEN.
 Ⓢ NE PAS ENGAGER LA MARCHÉ ARRIÈRE BRUSQUEMENT A GRANDE VITESSE.
 Ⓢ BIJ HOGE SNEELHEID NIET PLOTSELING IN DE ACHTERUIT-VERSNELLING SCHAKELEN!
 Ⓢ NON INGRANARE IMPROVVISAMENTE LA RETROMARCIA AD ALTA VELOCITÀ.
 Ⓢ NO PONER LA MARCHA ATRÁS DE REPENTE CUANDO CIRQUELE A ALTA VELOCIDAD.
 Ⓢ NÃO MUDE REPENTINAMENTE PARA MARCHA ATRÁS A ALTA VELOCIDADE.
 Ⓢ ÄLÄ VÄRÄÄÄ AKKILESTI PERUUTUSVAIHEELLE NOPEASSA VAUHDISSA.
 Ⓢ QIETI MA IKKE SETTIES I REVERS NÅR DET KJØRES MED HØY HASTIGHET.
 Ⓢ LÄGG INTE PLOTSLIGT I BACKEN VID KÖRNING PÅ HOG HASTIGHET.
 Ⓢ 고속에서 갑자기 후진으로 전환하지 마십시오.

READ OWNER'S MANUAL

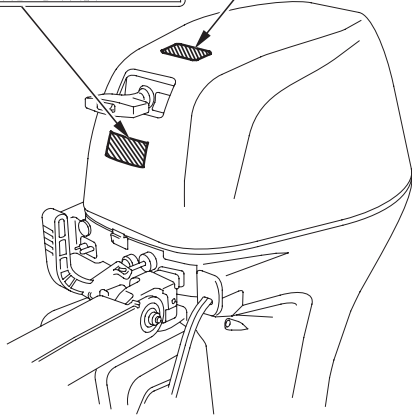

READ OWNER'S MANUAL EMERGENCY ENGINE STARTING

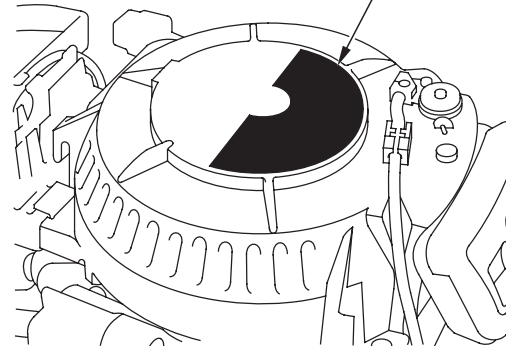
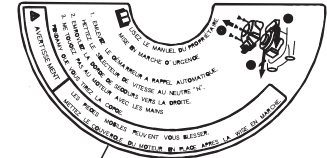

The labels shown here contain important safety information. Please read them carefully. These labels are considered permanent parts of your outboard motor. If a label comes off or becomes hard to read, contact an authorized Honda Marine dealer for a replacement.

OUTBOARD MOTOR SAFETY

GASOLINE FLAMMABLE DANGER
GAZOLINE INFLAMMABLE DANGEREUX
GASOLINA PELIGRO FLAMABLE

FUEL CAUTION

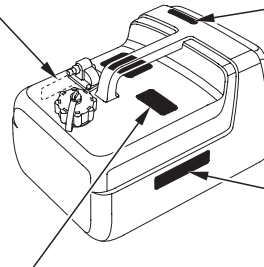

CAUTION

KEEP TOTALLY CLOSED WHEN NOT IN USE. KEEP AWAY FROM HEAT, SPARKS, AND OPEN FLAME. SECURE ABOVE DECK IN WELL VENTILATED AREA. DO NOT USE FOR LONG TERM FUEL STORAGE.

GASOLINE FLAMMABLE DANGER
GAZOLINE INFLAMMABLE DANGEREUX

DANGER

HARMFUL OR FATAL IF SWALLOWED. KEEP OUT OF REACH OF CHILDREN. IF SWALLOWED, DO NOT INDUCE VOMITING. CALL A PHYSICIAN IMMEDIATELY.

AT CAUTION



[G type]

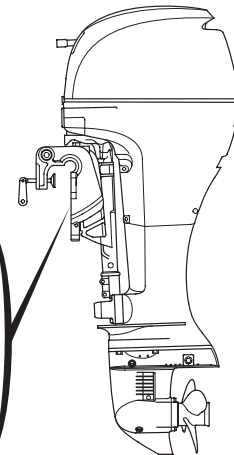
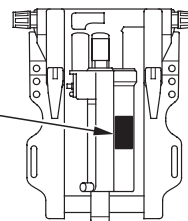

OUTBOARD MOTOR SAFETY

Canadian Types



- **Honda outboard motor is designed to give safe and dependable service if operated according to instructions. Read and understand the Owner's Manual before operating the outboard motor. Failure to do so could result in personal injury or equipment damage.**



- **Gasoline is harmful or fatal if swallowed. Keep the fuel tank out of reach of children.**
- **Gasoline is extremely flammable and is explosive under certain conditions. Refuel in a well-ventilated area with the engine stopped.**
- **Do not smoke or allow flames or sparks where the engine is refueled or where gasoline is stored.**
- **Do not overfill the fuel tank. After refueling make sure that the fuel filler cap is closed properly and securely.**

- **Be careful not to spill any fuel while refueling. Spilled fuel or fuel vapor may ignite. If any fuel is spilled, make sure that the area is dry before starting the engine.**

CONTROLS AND FEATURES

CONTROL AND FEATURE IDENTIFICATION CODES

Model	BF8D			BFP8D		
Type	SHA SHC	LHA LHC	LHSA	XHSA	LHTA	LRTA
Shaft Length	S	•				
	L		•		•	•
	X			•		
Tiller Handle	•	•	•	•	•	
Remote Control						•
Electric Starter			•	•	•	•
Power Tilt					•	•
Power Thrust Propeller				•	•	•
Battery Charging DC Receptacle	•	•				
Tachometer						*

* : Optional equipment

Refer to this chart for an explanation of the Type Codes used in this manual to identify control and feature applications.

BF8D/BFP8D are provided with the following types according to the shaft length, control system, tilt system, and start system.

- Shaft Length
S: Short Shaft
L: Long Shaft
X: Extra Long Shaft
- Control System
H: Tiller Handle Control
R: Remote Control

- Tilt system
T : Power Tilt (with hydraulic assist function)

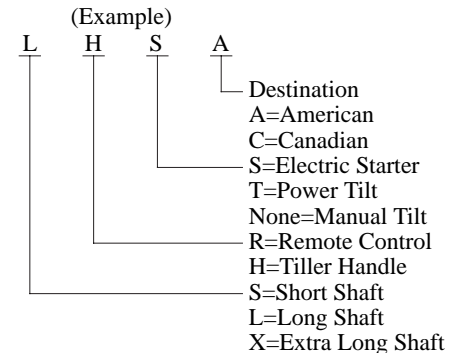

CONTROLS AND FEATURES

Model	BF9.9D						BFP9.9D						
Type	SHA SHC	LHA LHC	SHSA SHSC	LHSA	LRA	LRTC	XHA	XHSA XHSC	LHSC	LHTA	XHTA	LRTA	XRTA
Shaft Length	S	•	•										
	L		•	•	•	•			•	•		•	
	X						•	•			•		•
Tiller Handle	•	•	•	•			•	•	•	•	•		
Remote Control					•	•						•	•
Electric Starter			•	•	•	•		•	•	•	•	•	•
Power Tilt						•				•	•	•	•
Power Thrust Propeller							•	•	•	•	•	•	•
Battery Charging DC Receptacle	•	•					•						
Tachometer					*	*						*	*

* : Optional equipment

Refer to this chart for an explanation of the Type Codes used in this manual to identify control and feature applications.

BF9.9D/BFP9.9D are provided with the following types according to the shaft length, control system, tilt system, and start system.

- Shaft Length
S: Short Shaft
L: Long Shaft
X: Extra Long Shaft
- Control System
H: Tiller Handle Control
R: Remote Control

- Tilt system
T : Power Tilt (with hydraulic assist function)

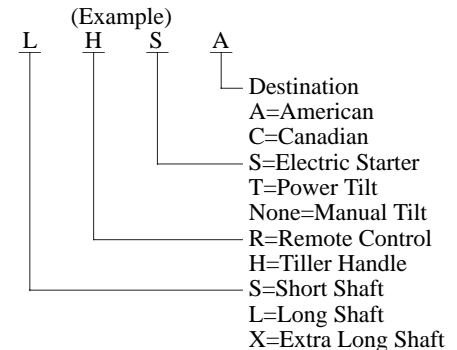

CONTROLS AND FEATURES

Model		BF15D							BFP15D		
Type		SHA SHC	LHA LHC	SHSA SHSC	LHSA	SHTA	LHGC	LHTA	LRTA	XHTA	XRTA
Shaft Length	S	•		•		•					
	L		•		•		•	•	•		
	X									•	•
Tiller Handle		•	•	•	•	•	•	•		•	
Remote Control									•		•
Electric Starter				•	•	•	•	•	•	•	•
Gas Assist Tilt							•				
Power Tilt						•		•	•	•	•
Power Thrust Propeller										•	•
Battery Charging DC Receptacle		•	•								
Tachometer									*		*

* : Optional equipment

Refer to this chart for an explanation of the Type Codes used in this manual to identify control and feature applications.

BF15D/BFP15D are provided with the following types according to the shaft length, control system, tilt system, and start system.

- Shaft Length
S: Short Shaft
L: Long Shaft
X: Extra Long Shaft
- Control System
H: Tiller Handle Control
R: Remote Control

- Tilt system
G : Gas Assist Tilt (with gas damper assist function)
T : Power Tilt (with hydraulic assist function)

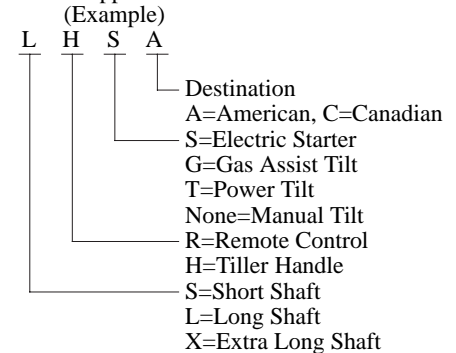

CONTROLS AND FEATURES

Model	BF20D								
Type	SHA SHC	LHA LHC	SHSC	SHTA SHTC	LHTA LHTC	LHGC	SRTA SRTC	LRTA LRTC	
Shaft Length	S	•		•	•			•	
	L		•		•	•			•
Tiller Handle	•	•	•	•	•	•			
Remote Control							•	•	
Electric Starter			•	•	•	•	•	•	
Gas Assist Tilt						•			
Power Tilt				•	•		•	•	
Power Thrust Propeller									
Battery Charging DC Receptacle	•	•							
Tachometer							*	*	

* : Optional equipment

Refer to this chart for an explanation of the Type Codes used in this manual to identify control and feature applications.

BF20D are provided with the following types according to the shaft length, control system, tilt system, and start system.

- Shaft Length
S: Short Shaft
L: Long Shaft
- Control System
H: Tiller Handle Control
R: Remote Control

- Tilt system
G : Gas Assist Tilt (with gas damper assist function)
T : Power Tilt (with hydraulic assist function)

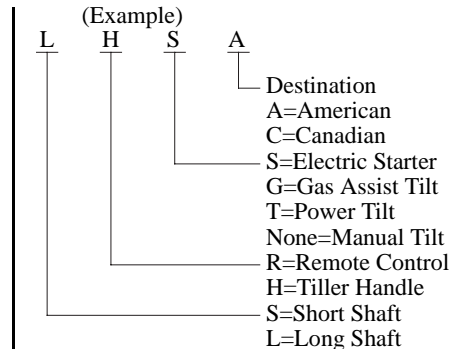

CONTROLS AND FEATURES

COMPONENT AND CONTROL LOCATIONS H Type (tiller handle)

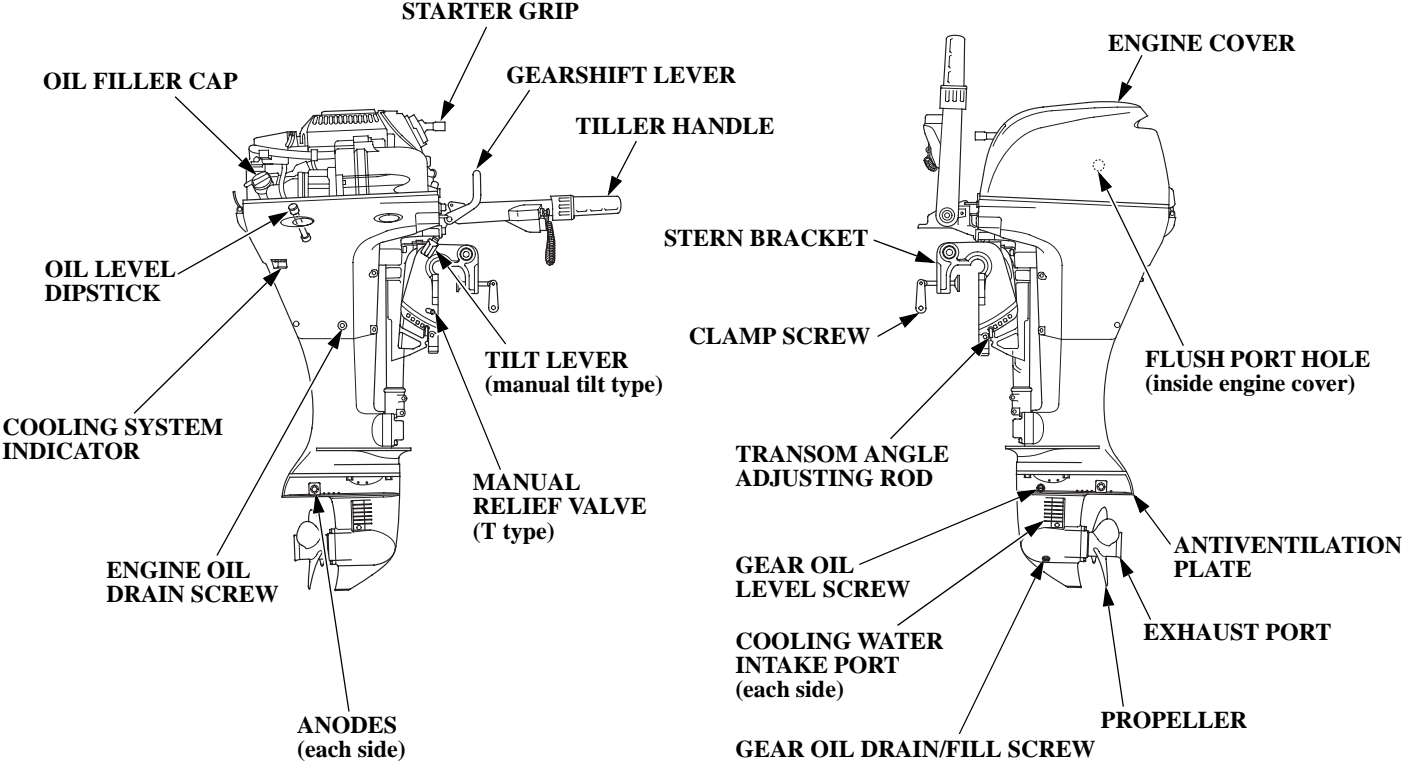

CONTROLS AND FEATURES

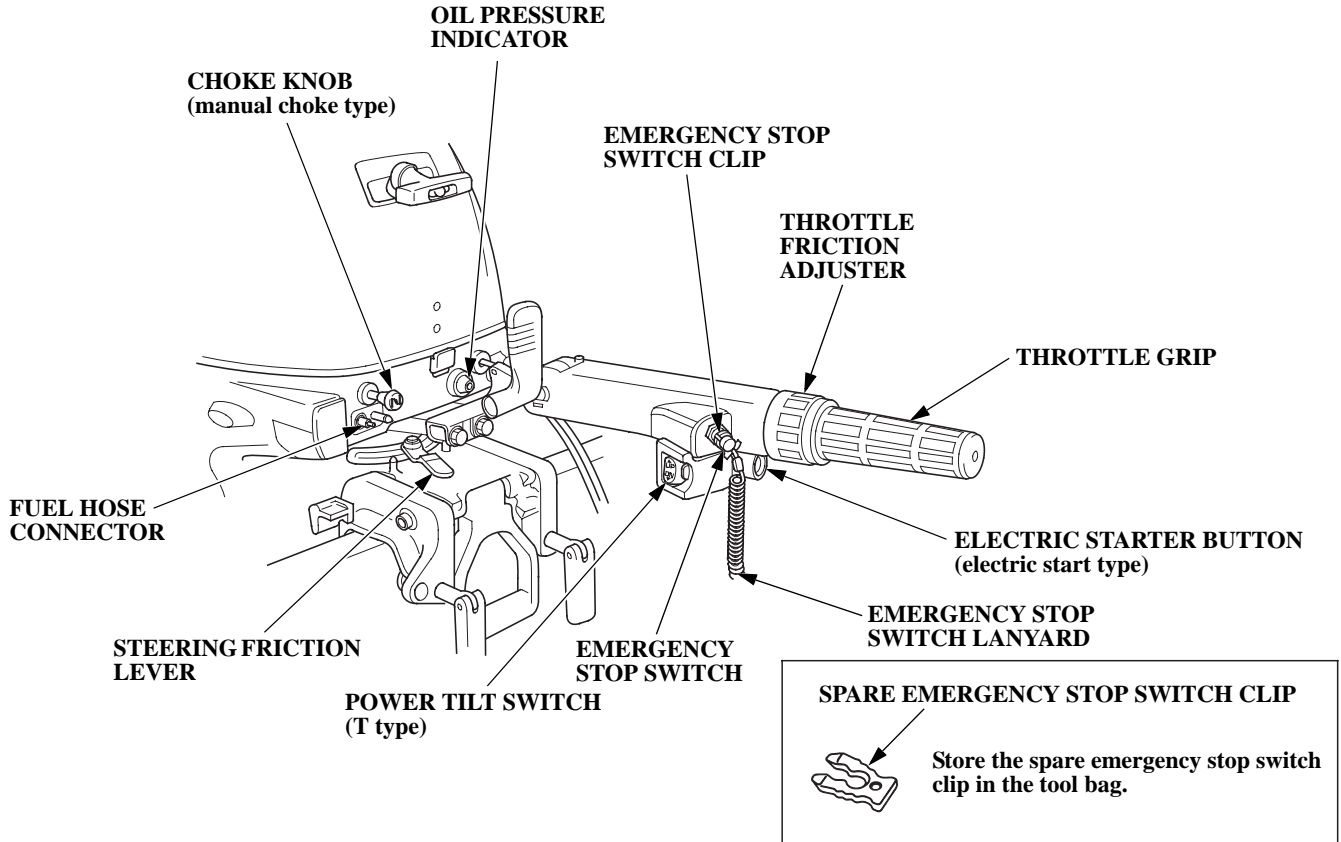

CONTROLS AND FEATURES

R Type (remote control)

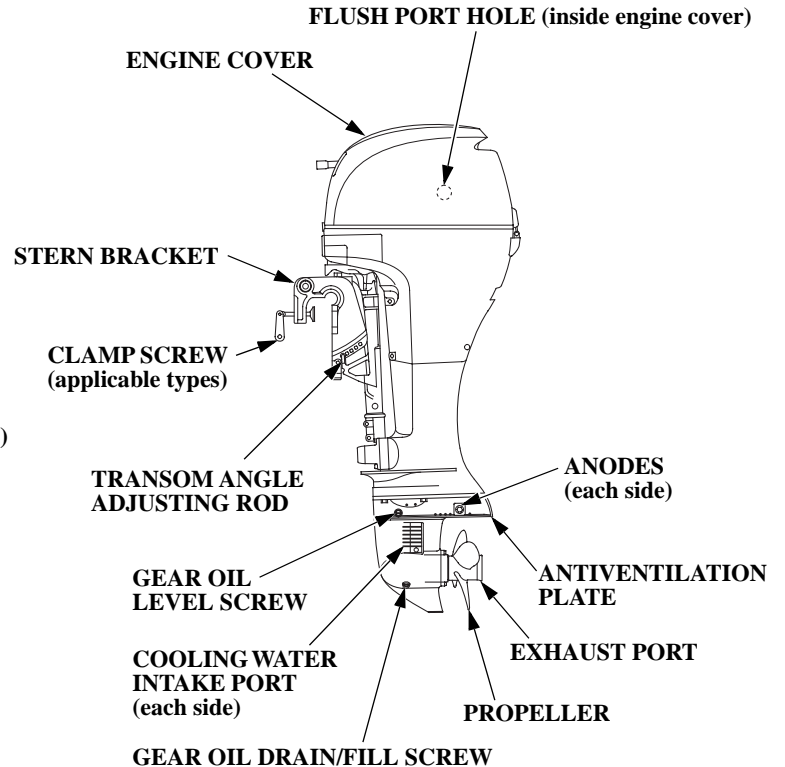
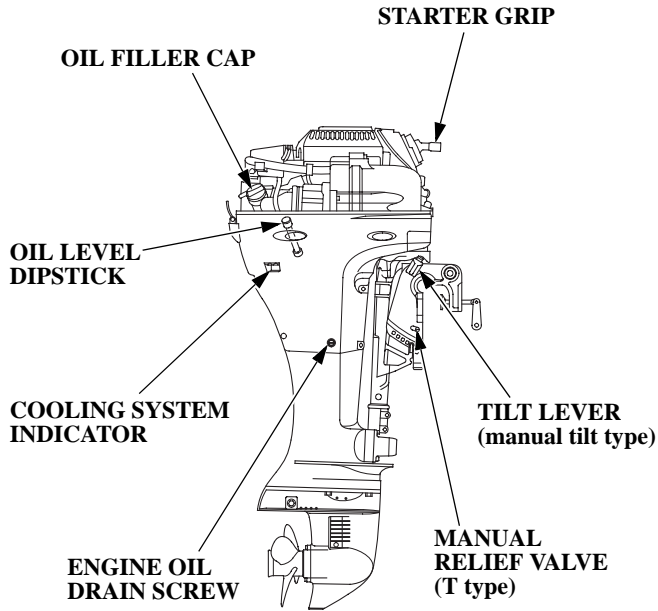

CONTROLS AND FEATURES

Remote Control box (R Type)

[standard equipment (Canadian types)]

[optional equipment (American types)]

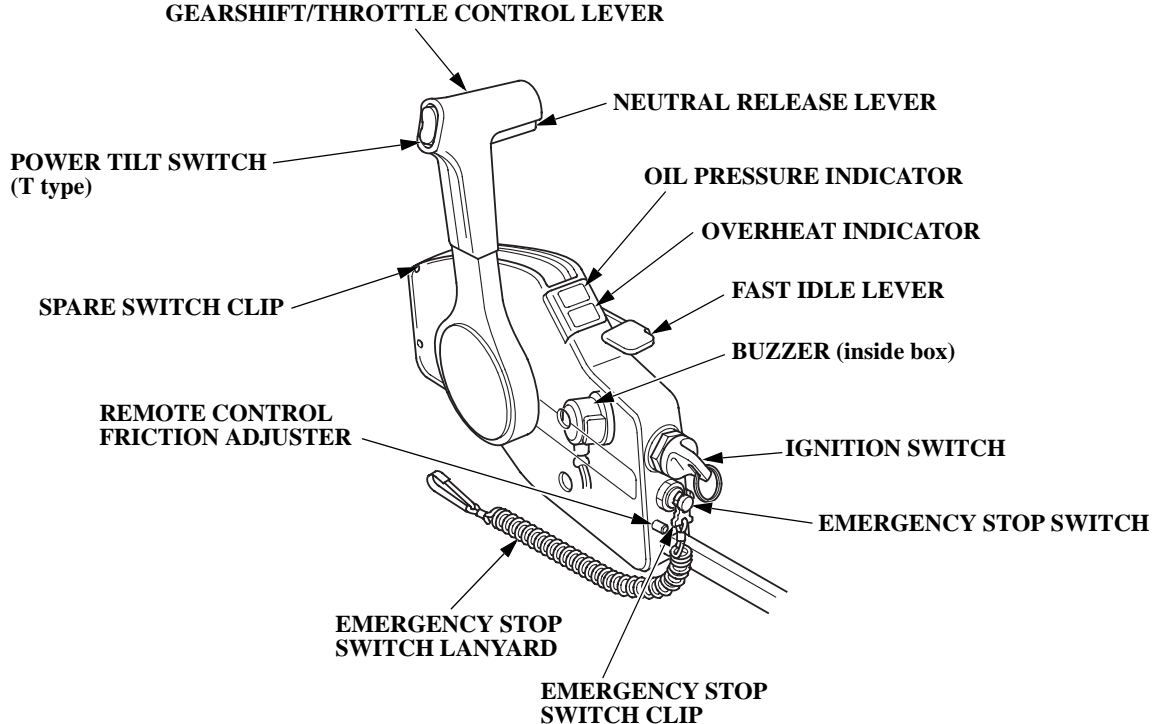

Tachometer
[optional equipment (R type)]

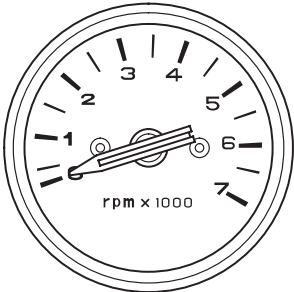

TACHOMETER

Portable Fuel Tank

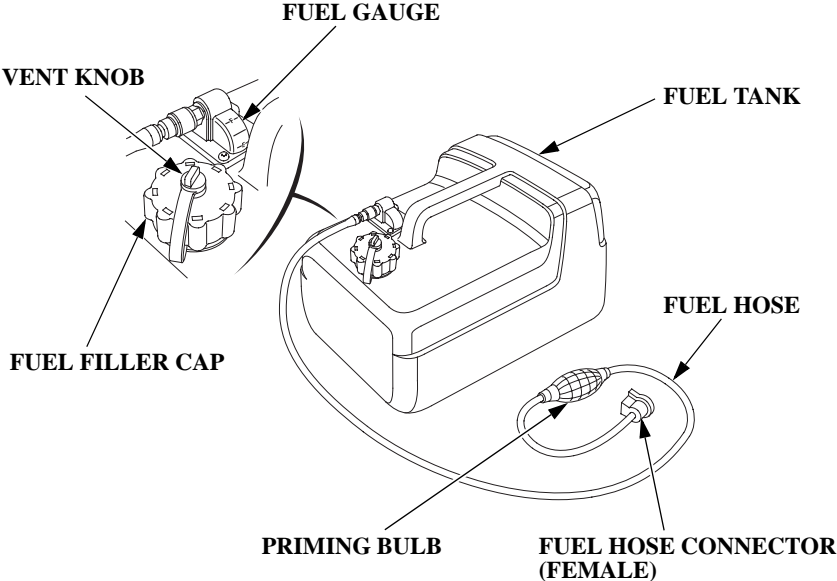

CONTROLS AND FEATURES

CONTROLS

H Type (tiller handle)

Emergency Stop Switch Clip and Emergency Stop Switch

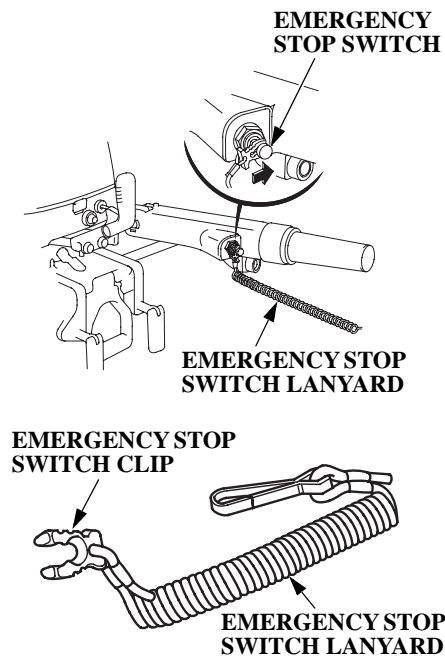

The emergency stop switch has controls for normal engine stopping and emergency engine stopping.

The emergency stop switch clip must be inserted in the emergency stop switch in order for the engine to start and run. The emergency stop switch lanyard must be attached securely to the operator or to the operator's PFD (Personal Flotation Device).

When used as described, the emergency stop switch and emergency stop switch lanyard system stops the engine if the operator falls away from the controls.

A spare switch clip is supplied with the outboard motor.

Choke Knob (manual choke type)

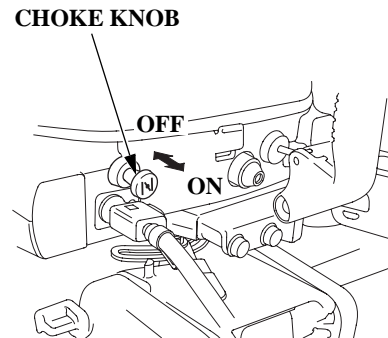

The choke knob opens and closes the choke valve in the carburetor.

The ON position enriches the fuel mixture for starting a cold engine.

The OFF position provides the correct fuel mixture for operation after starting, and for restarting a warm engine.

Throttle Grip

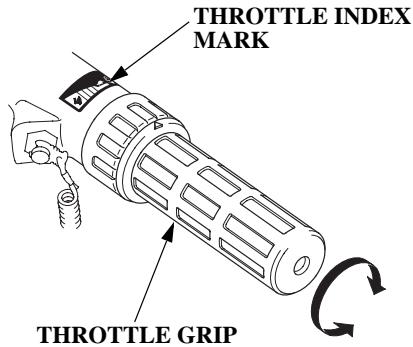

The throttle grip controls engine speed.

An index mark on the tiller arm shows throttle position and is helpful for setting the throttle correctly when starting (p. 50).

Throttle Friction Adjuster

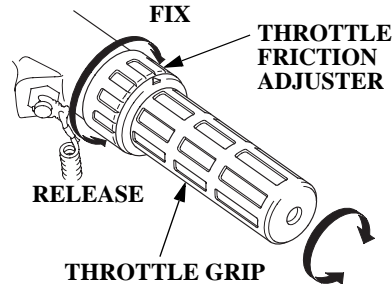

The throttle friction adjuster adjusts resistance to throttle grip rotation.

Turn the adjuster clockwise to increase friction for holding a throttle setting while cruising.

Turn the adjuster counterclockwise to decrease friction for easy throttle grip rotation.

Gearshift Lever

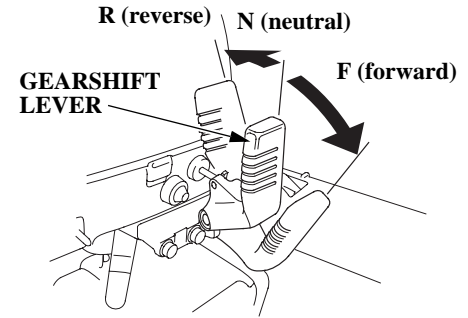

The gearshift lever is used to select F (forward), N (neutral), or R (reverse) gears.

The engine can be started with the gearshift lever in the N (neutral) position only.

If the gearshift lever is in the F (forward) or R (reverse) position, the recoil starter will not operate, and the electric starter button (applicable models) will not operate the starter motor.

CONTROLS AND FEATURES

Starter Grip

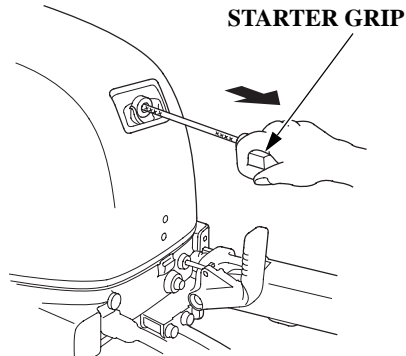

Pulling the starter grip operates the recoil starter to crank the engine for starting.

The engine will not start unless the gearshift lever is in the N (neutral) position (p. 50) and the emergency stop switch clip is in the emergency stop switch.

Electric Starter Button (types equipped with electric starter)

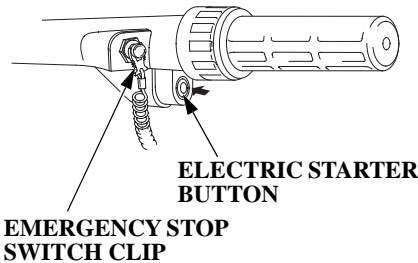

Press the starter button to operate the electric starter for starting the engine.

The electric starter button can be used to start the engine only when the gearshift lever is in the N (neutral) position (p. 50), and the emergency stop switch clip is in the emergency stop switch.

Steering Friction Lever

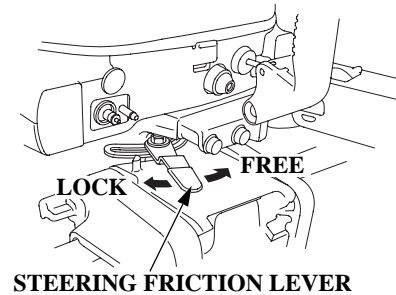

The steering friction lever adjusts steering resistance.

Less friction allows the outboard motor to turn more easily. More friction helps to hold a steady course while cruising or to prevent the outboard motor from swinging while trailering the boat.

Power Tilt Switch (T type)

Press UP to tilt
the outboard
motor up.

Press DN to tilt
the outboard
motor down.

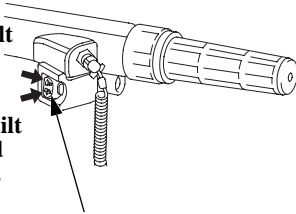

POWER TILT SWITCH

The rocker type power tilt switch has UP and DN (down) positions for changing the angle of the outboard motor.

Power tilt is a convenience for tilting the outboard motor, shallow water operation, and trailering only. It is not designed to be used as a trim function to adjust the trim angle of the boat.

During shallow water operation, beaching, launching, or mooring, proceed at low speed with a small throttle opening and tilt the outboard motor up as necessary (p. 65).

CONTROLS AND FEATURES

R Type (remote control) [standard equipment (Canadian types)] [optional equipment (American types)]

For panel-mount or top-mount remote control information, refer to the instructions provided with the remote control equipment.

Ignition Switch

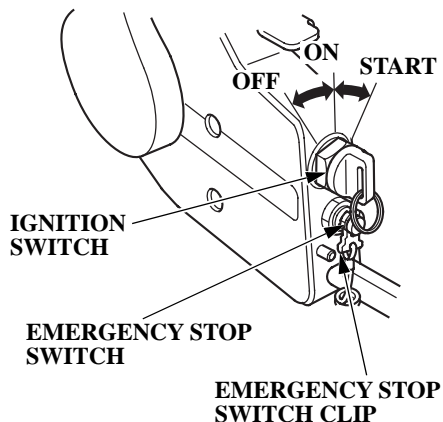

The ignition switch controls the ignition system and the starter motor.

Turning the ignition switch key to the START position operates the starter motor. The key automatically returns to the ON position when released from the START position.

The ignition switch can be used to start the engine only when the gearshift/throttle control lever is in the N (neutral) position (p. 52), and the emergency stop switch clip is in the emergency stop switch.

Turning the ignition switch to the OFF position stops the engine.

Emergency Stop Switch Clip and Emergency Stop Switch

EMERGENCY STOP SWITCH

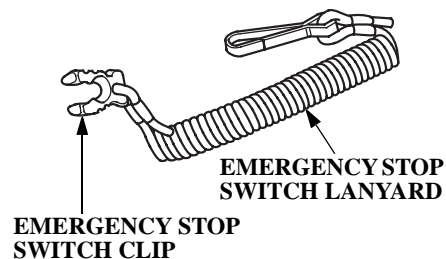
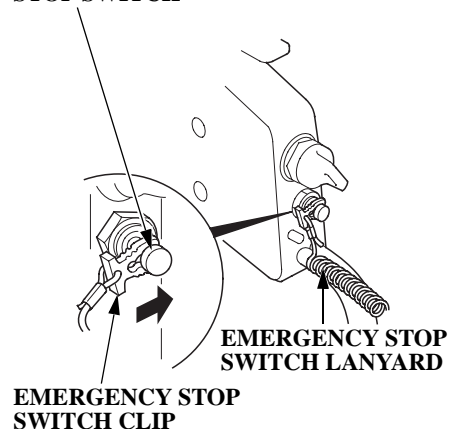

The emergency stop switch clip must be inserted in the emergency stop switch in order for the engine to start and run. The emergency stop switch lanyard must be attached securely to the operator or to the operator's PFD (Personal Flotation Device).

When used as described, the emergency stop switch clip and emergency stop switch lanyard system stops the engine if the operator falls away from the controls. A spare switch clip is stored in a slot in the control housing.

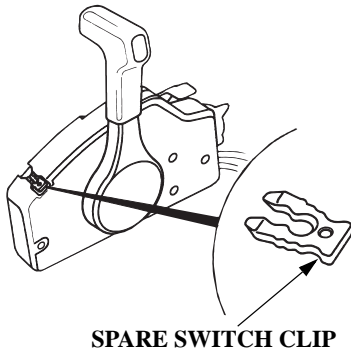

Fast Idle Lever

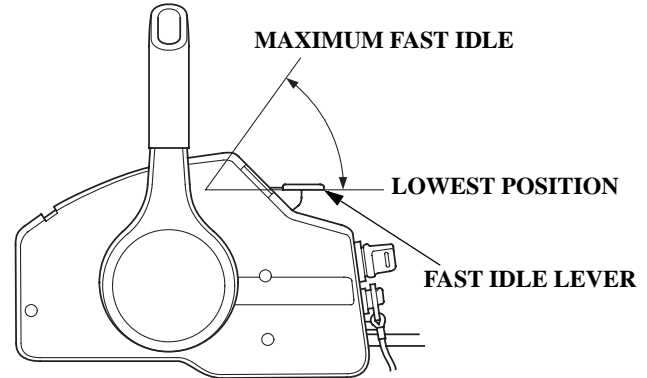

The fast idle lever is used to set idle speed during warm-up.

The lever will not move unless the gearshift/throttle control lever is in the N (neutral) position. The fast idle lever must be in its lowest position for you to move the gearshift/throttle control lever out of neutral.

Leave the fast idle lever in the lowest position to provide a rich fuel mixture for starting a cold engine.

Lift the fast idle lever to accelerate the warm up of a cold engine after starting and to start a warm engine.

CONTROLS AND FEATURES

Gearshift/Throttle Control Lever

GEARSHIFT/THROTTLE
CONTROL LEVER

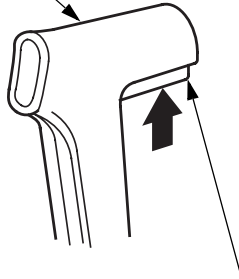

NEUTRAL RELEASE LEVER

The control lever automatically locks itself in the N (neutral) position. To move the lever out of the N (neutral) position, you must squeeze the neutral release lever on the underside of the lever handle.

GEARSHIFT/THROTTLE
CONTROL LEVER

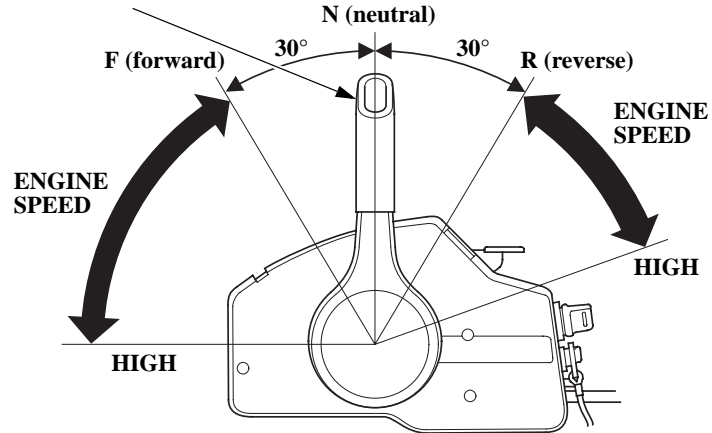

The gearshift/throttle control lever controls engine speed and selects F (forward), N (neutral), or R (reverse) gears.

Moving the control lever 30° from N (neutral) selects the gear, and further movement increases engine speed.

A friction adjuster near the base of the control lever adjusts the operating resistance of the control lever (p. 60).

Less friction allows easier control lever movement. More friction helps to hold a steady throttle setting while cruising.

Power Tilt Switch (T type)

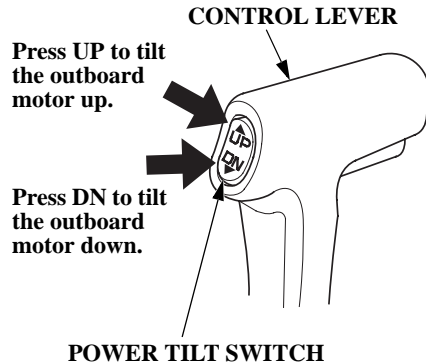

The rocker type power tilt switch is located on the control lever and has UP and DN (down) positions for changing the angle of the outboard motor.

Power tilt is a convenience for tilting the outboard motor, shallow water operation, and trailering only. It is not designed to be used as a trim function to adjust the trim angle of the boat.

During shallow water operation, beaching, launching, or mooring, proceed at low speed with a small throttle opening and tilt the outboard motor up as necessary (p. 65).

Manual Relief Valve (T type)

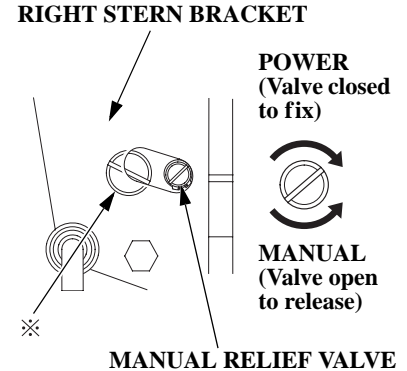

※ : Do not turn this screw. If this screw is turned hydraulic oil will bleed out of the power tilt system. Should this happen it will be necessary to consult your authorized Honda Marine dealer and have the system refilled.

The outboard motor can be tilted manually after opening the manual relief valve. This allows the outboard motor to be tilted up or down when no battery is connected.

CONTROLS AND FEATURES

Tilt Lock Lever (G and T types)



The tilt lock lever is used to support the outboard motor in the fully-raised position.

When the boat is to be moored for a long time, tilt the outboard motor up as far as it will go. Then move the tilt lock lever to the LOCK position, and gently lower the outboard motor until the lever contacts the stern bracket.

Common Controls

Engine Cover Latch

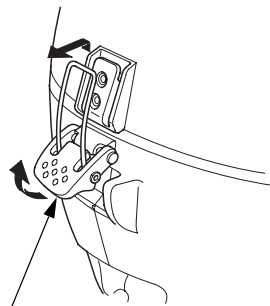

ENGINE COVER LATCH

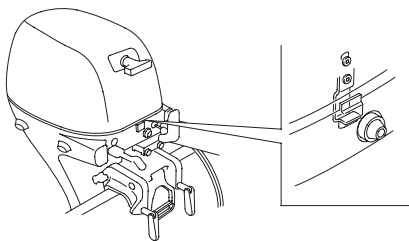

The engine cover latch fastens the engine cover to the outboard motor.

Transom Angle Adjusting Rod

The transom angle adjusting rod limits the tilt angle of the outboard motor when fully lowered.

(manual tilt/SH and LH types)

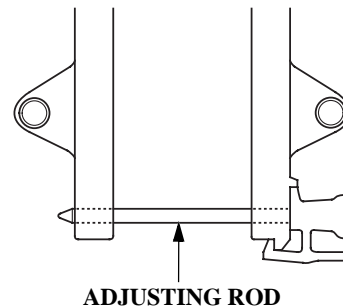

(manual tilt/XH and R types)

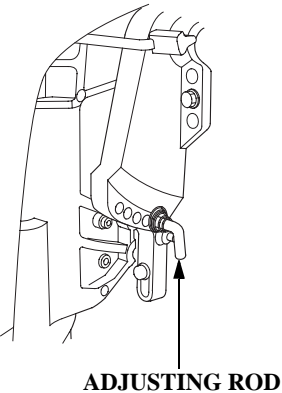

(G and T types)

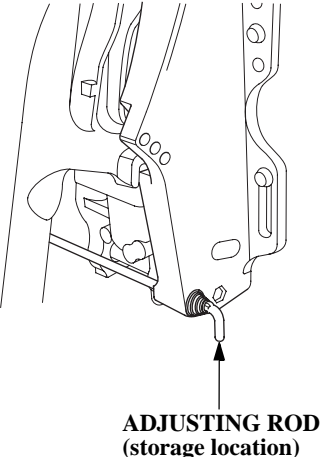

There are four transom angle adjustment positions. Three are controlled by the adjusting rod and the fourth is controlled by the stern bracket. In order to use the fourth position, remove the adjusting rod and store it in the storage location; then lower the outboard motor down to the stern bracket stop position.

Tilt Lever

(manual tilt type)

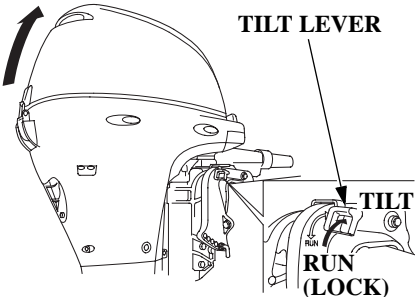

(G type)

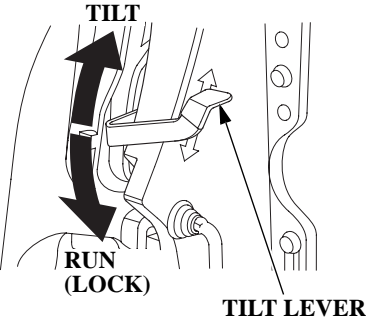

CONTROLS AND FEATURES

The tilt lever enables the outboard motor to be raised for shallow water operation, beaching, launching, or mooring.

To tilt, move the lever to the TILT position, then raise the outboard motor until the tilt mechanism engages at 22°, 37°, 63° or 64° (G type: 64°) on P. 64.

BF8D/BFP8D/BF9.9D/BFP9.9D

63° : Tiller handle S and L type.

64° : Tiller handle X type and
Remote control type.

BF15D/BFP15D/BF20D

63° : Tiller handle S type.

64° : Tiller handle G, L, X type and
Remote control type.

INSTRUMENTS

Fuel Gauge

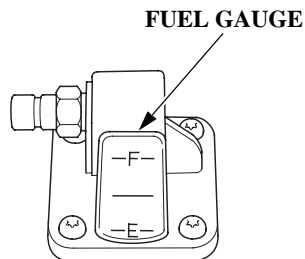

A fuel gauge is built into the fuel tank connector of the portable fuel tank.

Tachometer [optional equipment (R Type)]

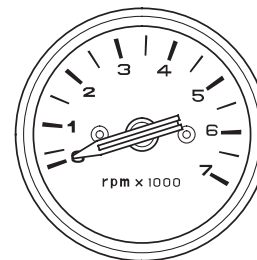

TACHOMETER

The tachometer shows engine speed in revolutions per minute.

A tachometer will help to select the correct propeller.

INDICATORS

Oil Pressure Indicator (R type)

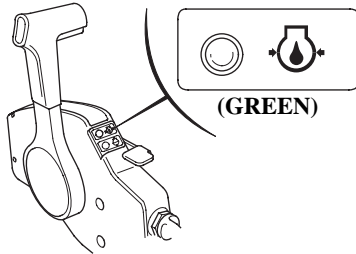

(H type)

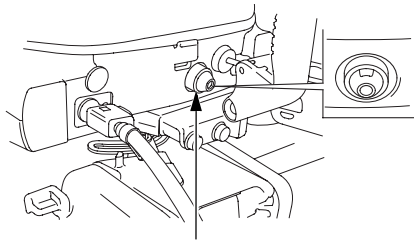

OIL PRESSURE INDICATOR

When the green light is lit, oil pressure is OK.

If oil pressure becomes low, the green light will go off, and the engine protection system will limit engine speed. Refer to *TAKING CARE OF UNEXPECTED PROBLEMS*, p. 106.

Remote controls are also equipped with a buzzer that sounds continuously when the green light goes off.

The buzzer sound stops below an engine speed of 1,400 rpm.

Low oil pressure indicates that the engine oil level is low or that there is a problem with the engine lubrication system.

Overheat Indicator (R type)

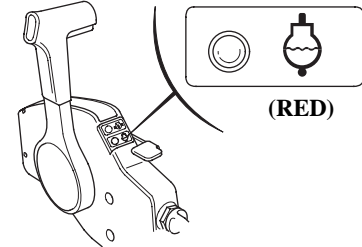

(R type)

When the overheat protection system is activated, the red overheat light will come on, a buzzer will sound continuously and the engine speed will be reduced to 1,800 rpm. If the condition persists for another 20 seconds, the engine will shut off. Refer to *TAKING CARE OF UNEXPECTED PROBLEMS*, p. 107.

CONTROLS AND FEATURES

(H type)

When the overheat protection system is activated, the engine speed will be reduced to 1,800 rpm. If the condition persists for another 20 seconds, the engine will shut off.

Refer to *TAKING CARE OF UNEXPECTED PROBLEMS*, p. 107.

Engine overheating may be the result of clogged water intakes.

Cooling System Indicator

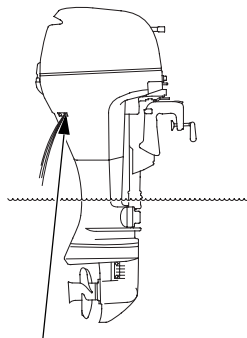

COOLING SYSTEM INDICATOR

Water should flow from the cooling system indicator while the engine is running. This shows that water is circulating through the cooling system.

If water stops flowing while the engine is running, it indicates a cooling system problem, such as clogged water intakes, which will cause engine overheating. Refer to *TAKING CARE OF UNEXPECTED PROBLEMS*, on p. 107.

The cooling system indicator port can also become plugged.

OTHER FEATURES

Rev Limiter

The engine is equipped with a rev limiter to prevent the possibility of mechanical damage from excessive engine speed.

The rev limiter may be activated during operation, limiting engine speed, if the outboard motor is tilted excessively, or when propeller ventilation occurs during a sharp turn.

If the rev limiter is activated, check the tilt angle of the outboard motor.

Check to see if the correct propeller is installed.

Automatic Choke (types equipped with electric starter)

The engine is equipped with an automatic choke so that the choke system operation is not needed when starting the engine.

Anodes

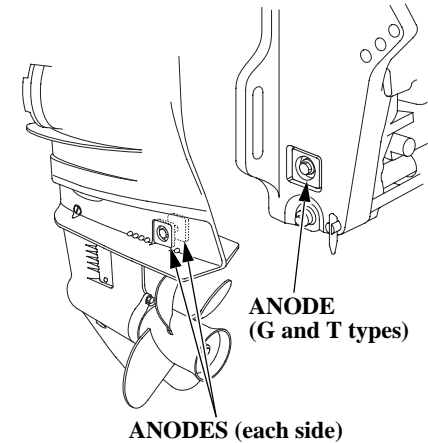

The anodes are made of a sacrificial material that helps to protect the outboard motor from corrosion.

There are two anodes on the gear case, one on the stern bracket.

CONTROLS AND FEATURES

Portable Fuel Tank

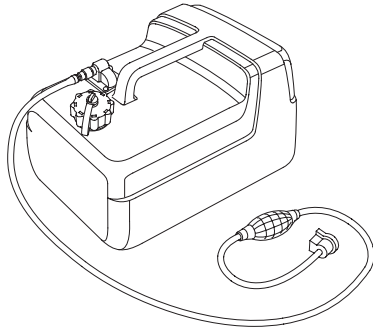

The portable fuel tank has a capacity of 3.2 US gal (12L) and has a fuel gauge built into the fuel tank connector.

Fuel Filler Cap Vent Knob

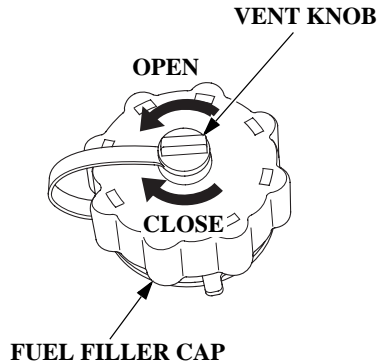

The fuel filler cap is provided with a vent knob to seal the portable fuel tank for carrying it to and from the boat. Open the vent by turning the vent knob counterclockwise all the way before starting the engine.

Fuel Priming Bulb

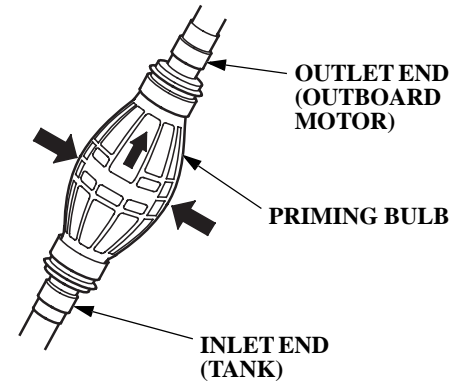

A priming bulb is built into the fuel hose that connects the fuel tank to the outboard motor.

Before starting the engine, squeeze the priming bulb until it feels firm. This will ensure that fuel is supplied to the engine.

INSTALLATION

Correct and secure installation is essential for safe boating and good performance. Follow the installation instructions provided in this manual.

POWER REQUIREMENTS

Before installation, check to be sure that the outboard motor does not exceed the recommended maximum horsepower for the boat on which it is to be installed. Refer to the boat's certification plate for recommended maximum horsepower. If the certification plate information is not available, contact the boat dealer or manufacturer.

For most applications, the outboard motor should have a horsepower rating which provides 80% of the maximum recommended horsepower for the boat.

BOAT TRANSOM REQUIREMENTS

Honda BF8D/BFP8D/BF9.9D/BFP9.9D/BF15D/BFP15D and BF20D outboard motors can be installed on a boat transom having a thickness range of 1.3 – 2.2 inches (35 – 57 mm).

INSTALLATION POSITION

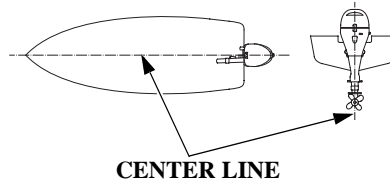

Install the outboard motor on the center of the boat transom.

The antiventilation plate of the outboard motor should be 0 – 2 in (0 – 50 mm) below the bottom of the boat. When the outboard motor is mounted on a sailboat, the antiventilation plate should be

4 in (100 mm) or more below the surface of the water. For unusual situations, see your Honda Marine dealer for advice.

The correct dimensions differ according to the type of boat and the configuration of the bottom of the boat. Follow the manufacturer's recommended installation height.

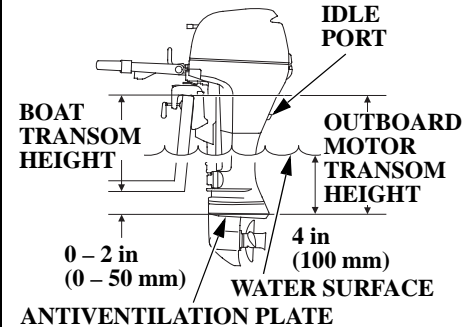

Type:	Outboard Motor Transom Height
S:	17.0 in (433 mm)
L:	22.2 in (563 mm)
X:	27.7 in (703 mm)

INSTALLATION

When the outboard motor is installed extremely low, the idle port may be immersed and the engine may become hard to start or may run poorly. Check that the idle port is high enough from the water level when the engine is stopped with the boat fully loaded.

If the outboard motor is installed too low, the boat will squat and be hard to plane, and the outboard motor will spray water that may enter the boat. It will tend to porpoise, and high-speed stability will be reduced.

If the outboard motor is installed too high, that will cause propeller ventilation.

Optimum installation height varies with boat type and bottom shape. Contact the boat manufacturer for any special recommendations that are unique to a specific model of boat.

If the transom needs to be modified to accommodate the outboard motor, contact the boat manufacturer and follow their recommendations for corrective action.

ATTACHMENT (types with clamp screws)

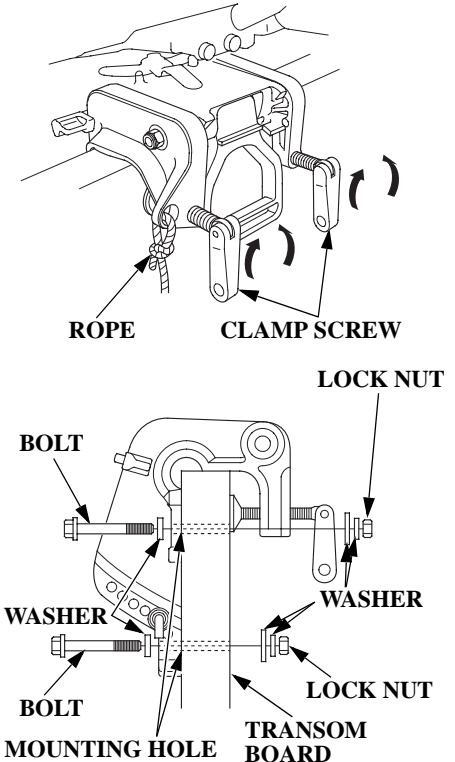

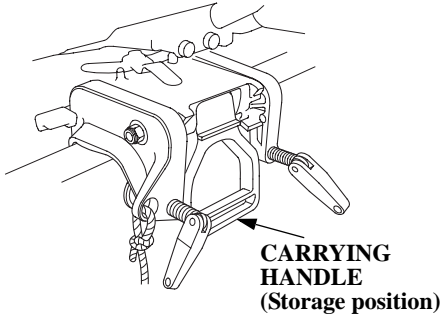

Attach the stern bracket to the transom and tighten the clamp screws. Push the carrying handle into the storage position.

Attach a rope from the boat to the hole in the stern bracket. This will help to prevent accidental loss of the outboard motor.

You may further secure the outboard motor by bolting the stern bracket to the boat transom. Use the optional mounting bolt and nut kit or other good quality stainless steel bolts, nuts, and washers. Apply silicone sealant to the bolt holes.

(types without clamp screws)

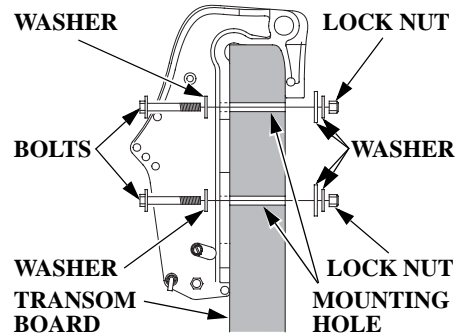

Attach the stern bracket to the boat transom with good quality stainless steel bolts, nuts, and washers. Apply silicone sealant to the bolts holes.

TRANSOM ANGLE ADJUSTMENT

Use the transom angle adjustment rod (p. 46) to adjust the angle of the outboard motor so the propeller is perpendicular to the surface of the water.

INSTALLATION

BATTERY CONNECTIONS

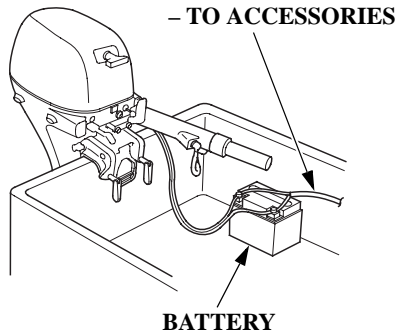

Honda BF8D/BFP8D/BF9.9D/BFP9.9D/BF15D/BFP15D and BF20D outboard motors produce a 12-volt, 6 or 12-ampere battery-charging current and are equipped for connection to a 12-volt battery. The battery-charging circuit is protected by a 20-ampere fuse located in the engine compartment.

The outboard motor's 12-volt output is designed to charge a "starting or cranking" battery only. It is not intended to charge a "deep-cycle" type battery. Lights and electrical accessories for the boat should be connected to the battery.

The battery should be kept in a corrosion-resistant battery box that is securely mounted in a location away from the fuel tank and protected from water and direct sunlight.

Types With Electric Starter

These types are equipped with battery cables. The positive (+) cable has a red band at the battery connector. The negative (-) cable has a black band at the battery connector.

For electric starter operation, use a 12-volt battery with an ampere-hour rating of at least 35 Ah (CCA 270).

Types With Manual Start

These types are equipped with a 12-volt DC battery-charging receptacle which can be wired to a 12-volt battery to power lights and electrical accessories for the boat.

Plug and Receptacle (types without electric starter)

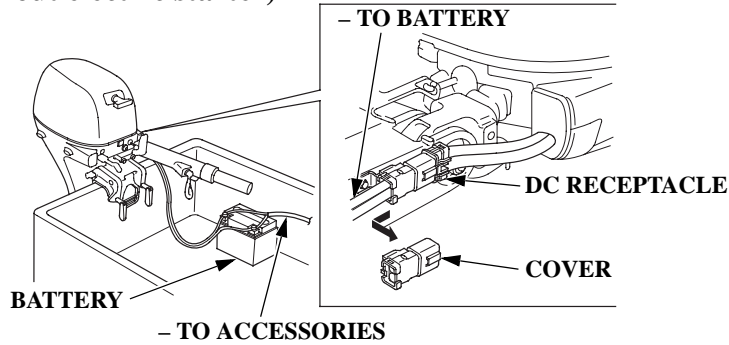

To prepare the outboard motor for connection to a battery, pull the cover off the DC receptacle, connect the battery charging wires to the plug. Attach the plug to the receptacle on the outboard motor.

The receptacle is provided with a cover, which should be attached when the plug is removed, in order to keep the receptacle clean and dry.

Battery

For complete information, refer to the battery manufacturer's instructions.

Minimum Requirements

12V-35Ah (CCA 270)

INSTALLATION

Battery Terminals

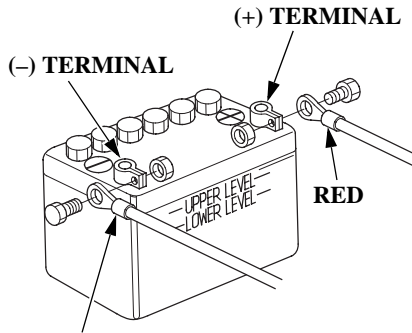

BLACK or GREEN

Connect the positive (+) battery cable to the positive (+) battery terminal, then connect the negative (-) battery cable to the negative (-) battery terminal.

The negative (-) battery cable should always be removed from the battery before connecting or disconnecting the positive (+) battery cable, so tools cannot cause a short circuit if they touch a grounded part while being used on the positive (+) battery terminal fitting.

NOTICE

- *Be careful to avoid connecting the battery in reverse polarity, as this will damage the battery-charging system in the outboard motor.*
- *Do not disconnect the battery cables while the engine is running. Disconnecting the cables while the engine is running will damage the outboard motor's electrical system.*

WARNING: Battery posts, terminals, and related accessories contain lead and lead compounds.
Wash your hands after handling.

ARE YOU READY TO GET UNDERWAY?

Your safety is your responsibility. A little time spent in preparation will significantly reduce your risk of injury.

Knowledge

Read and understand this manual. Know what the controls do and how to operate them.

Familiarize yourself with the outboard motor and its operation before you get underway. Know what to do in case of an emergency.

Familiarize yourself with all laws and regulations relating to boating and the use of outboard motors.

Safety

Always wear a PFD (Personal Flotation Device) while on the boat.

Attach the emergency stop switch lanyard securely to the operator or to the operator's PFD.

IS YOUR OUTBOARD MOTOR READY TO GO?

For your safety, and to maximize the service life of your equipment, it is very important to take a few moments before you operate the outboard motor to check its condition. Be sure to take care of any problem you find, or have your authorized Honda Marine dealer correct it, before you operate the outboard motor.

BEFORE OPERATION

⚠ WARNING

Improperly maintaining this outboard motor or failing to correct a problem before operation can cause a malfunction in which you could be seriously hurt or killed.

Always perform a pre-operation inspection before each operation, and correct any problem.

Before beginning your pre-operation checks, be sure the switch clip is removed or the ignition switch is in the OFF position.

BEFORE OPERATION

Safety Inspection

- Before each use, look around and underneath the engine for signs of oil or gasoline leaks.
- If you are using the portable fuel tank, make sure it is in good condition and properly secured in the boat (p. 48).
- Check that the fuel hose is undamaged and properly connected (p. 48).
- Wipe up any spills before starting the engine.
- Check the stern bracket to be sure the outboard motor is securely installed.
- Check that all controls are operating properly.
- Replace any damaged parts.

- Check that all fasteners are in place and securely tightened.
- Check the emergency stop switch for proper operation (p. 22, 26). Start the engine. Make sure the engine stops by pulling the emergency stop switch clip from the emergency stop switch (p. 57).

Maintenance Inspection

- Check the engine oil level (p. 75). Running the engine with a low oil level can cause engine damage.
- Check to be sure the propeller is undamaged and the castle nut is secured with the cotter pin (p. 92).
- Check that the anodes are securely attached to the gear case (p. 90) and are not excessively worn. The anodes help to protect the outboard motor from corrosion.
- Make sure the tool kit and emergency starter rope are onboard (p. 71). Replace any missing items.
- Check the fuel level in the fuel tank (p. 84).
- Check that the battery fluid is between the upper and lower levels, and the battery leads are connected securely (electric starter type).

SAFE OPERATING PRECAUTIONS

To safely realize the full potential of this outboard motor, you need a complete understanding of its operation and a certain amount of practice with its controls.

Before operating the outboard motor for the first time, please review the *IMPORTANT SAFETY INFORMATION* on page 7 and the chapter titled *BEFORE OPERATION*.

For your safety, do not start or run the engine in a confined or partly enclosed area. Your engine's exhaust contains poisonous carbon monoxide, a colorless, odorless gas that can collect rapidly. Breathing carbon monoxide can cause loss of consciousness and may lead to death.

BREAK-IN PROCEDURE

Break-in period: 10 hours

Proper break-in operation allows the moving parts to wear in smoothly for best performance and long service life. Avoid continuous operation at a steady speed.

First 15 minutes:

Run the engine at trolling speed. Use the minimum throttle opening necessary to operate the boat at a safe trolling speed.

Next 45 minutes:

Run the engine up to a maximum of 2,000 to 3,000 rpm, which is about 10% to 30% of maximum throttle opening. Operating at maximum 2,000 ~ 3,000 rpm should be limited to 50% of the 45 minutes.

Next 60 minutes:

Run the engine up to a maximum of 4,000 to 5,000 rpm, which is about 50% to 80% of maximum throttle opening. Operating at maximum 4,000 ~ 5,000 rpm should be limited to 50% of the 60 minutes. 30-second full-throttle bursts are OK, but do not operate the engine continuously at full throttle.

For boats that plane easily, bring the boat up on plane, and then reduce the throttle opening to the recommended rpm range.

Next 8 hours:

Do not run the engine at full throttle for more than 5 minutes at a time.

OPERATION

TRANSOM ANGLE ADJUSTMENT

(manual tilt/SH and LH types)

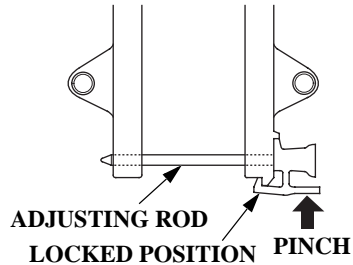

(manual tilt/XH and R types)

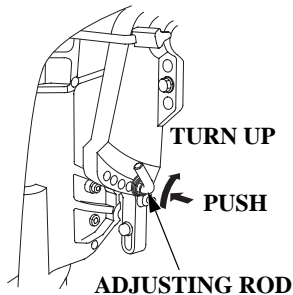

(G and T types)

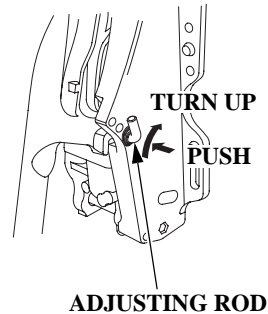

(XH, R, G and T types)

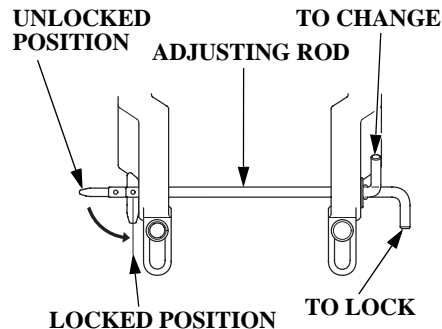

The transom angle adjusting rod limits the tilt angle of the outboard motor when fully lowered.

Proper adjustment prevents the outboard motor from being tilted too low (p. 62).

To adjust, first tilt the outboard motor so it is not resting on the rod.

(manual tilt/SH and LH types)
Pinch the end of the rod.

Remove the rod and reinsert it in the desired position.

Push the rod in and hook the end of the rod. Then release the rod.

(XH, R, G and T types)
Push the rod in and turn the end of the rod up, so the latch will fall into line with the rod.
Push the rod in and turn the end of the rod down, so the latch will fall to the locked position. Then release the rod.

NOTICE

Do not allow water to enter the idle exhaust port or the engine can be damaged.

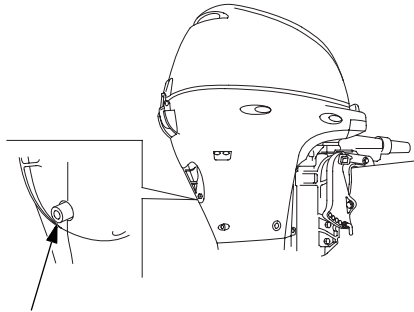

IDLE EXHAUST PORT

PORTABLE FUEL TANK

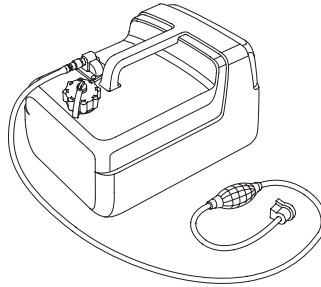

Place the portable fuel tank in a well-ventilated location, away from direct sunlight, to reduce the possibility of a gasoline vapor explosion.

To ensure that the outboard motor will be able to draw fuel from the tank, place the tank within 6 feet (2 m) of the outboard motor and not more than 3 feet (1 m) below the fuel connector on the outboard motor.

Secure the portable fuel tank in the boat so that it won't move around and become damaged.

⚠ WARNING

Gasoline is highly flammable and explosive.

You can be burned or seriously injured when handling fuel.

- Stop the engine and keep heat, sparks, and flame away.
- Handle fuel only outdoors.
- Wipe up spills immediately.

OPERATION

FUEL HOSE CONNECTIONS

Turn the portable fuel tank vent knob counterclockwise to the open position.

FUEL HOSE CONNECTOR

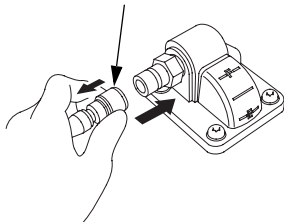

(FUEL TANK SIDE)

FUEL HOSE CONNECTOR

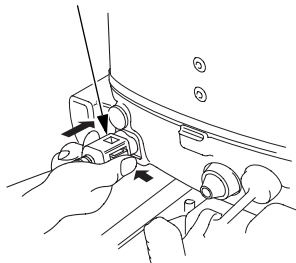

(OUTBOARD MOTOR SIDE)

Connect the fuel hose to the tank and the outboard motor, as shown. Be sure both connectors snap securely into place. Always disconnect the fuel hose when storing or transporting the outboard motor.

FUEL PRIMING

If you are using a portable fuel tank, turn the portable fuel tank vent knob counterclockwise to the open position.

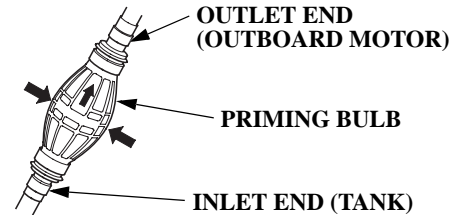

Hold the fuel priming bulb with the outlet end higher than the inlet end. Squeeze the priming bulb several times, until it feels firm, indicating that fuel has reached the carburetor.

Check to be sure there are no fuel leaks before starting the engine.

Do not touch the priming bulb with the engine running or when tilting up the outboard motor. The carburetor could overflow.

INFREQUENT OR OCCASIONAL USE

If your outboard motor will be used on an infrequent or intermittent basis, please refer to the fuel section of the STORAGE chapter (p. 95) for additional information regarding fuel deterioration.

STARTING THE ENGINE

H Type (tiller handle)

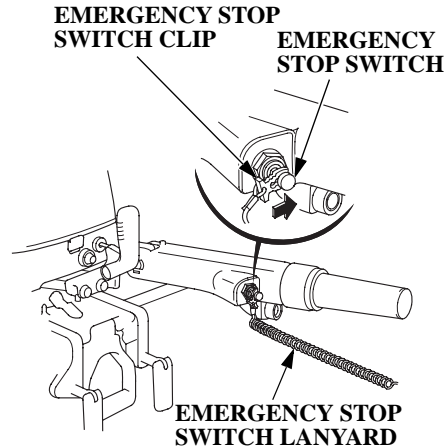

1. Put the emergency stop switch clip in the emergency stop switch, and attach the emergency stop switch lanyard securely to the operator or to the operator's PFD (Personal Flotation Device).

The engine will not start or run, unless the emergency stop switch clip is in the emergency stop switch.

The emergency stop switch clip and emergency stop switch lanyard system is a safety device that will stop the engine if you fall away from the controls while operating the boat.

Always attach the emergency stop switch lanyard securely to the operator or to the operator's PFD before starting the engine.

OPERATION

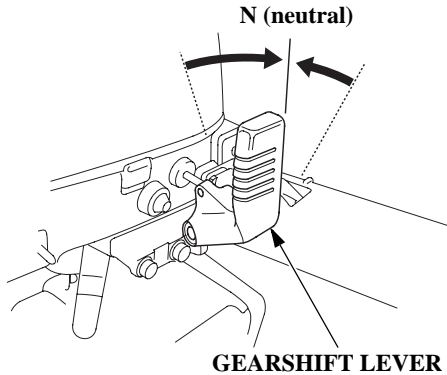

2. Check the position of the gearshift lever. It must be in the N (neutral) position for starting.

The engine will not start if the gearshift lever is in the F (forward) or R (reverse) position.

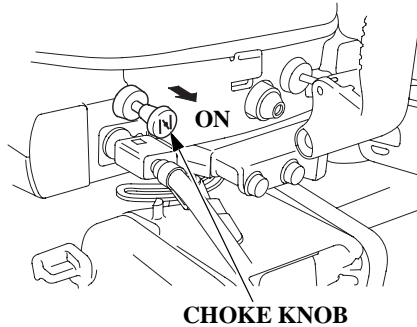

3. (Manual choke type)
To start a cold engine, pull the choke knob to the ON position. To restart a warm engine, leave the choke knob in the OFF position.

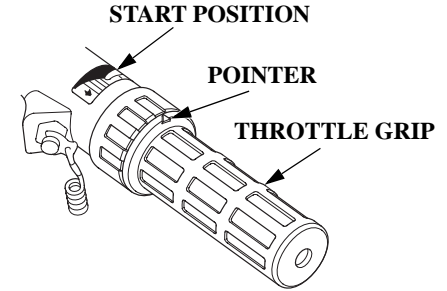

4. Turn the throttle grip to align the pointer with the START position to start the engine.

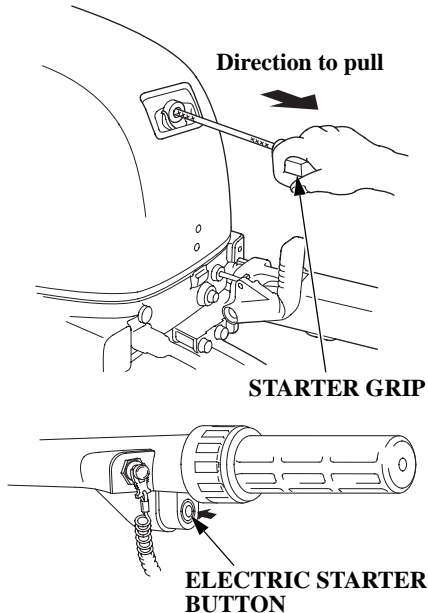

5. Recoil starter

Pull the starter grip lightly until you feel resistance, then pull briskly in the direction of the arrow as shown above.

Return the starter grip gently.

Electric starter

(electric start type)

Press the electric starter button and hold it there until the engine starts.

When the engine starts, release the button.

If the engine fails to start within 5 seconds, release the button, and wait at least 10 seconds before operating the starter again.

NOTICE

- *Using the electric starter for more than 5 seconds at a time will overheat the starter motor and can damage it.*
- *Pushing the electric starter button while the engine is running can damage the starter motor and flywheel.*

6. (Manual choke type)

If the choke knob was pulled to the ON position to start the engine, gradually push it to the OFF position as the engine warms up.

Also, as the engine warms up, the throttle grip can be turned to the SLOW position without stalling.

7. Before getting underway, allow the engine to warm-up sufficiently to ensure good performance.

During the warm-up period, check the oil pressure indicator (p. 33) and cooling system indicator (p. 34).

If the indicators show any abnormal condition, immediately stop the engine and determine the cause of the problem. Refer to *TAKING CARE OF UNEXPECTED PROBLEMS*, p. 106.

OPERATION

R Type (remote control)

[standard equipment (Canadian types)]

[optional equipment (American types)]

For panel-mount or top-mount remote control information, refer to the instructions provided with the remote control equipment.

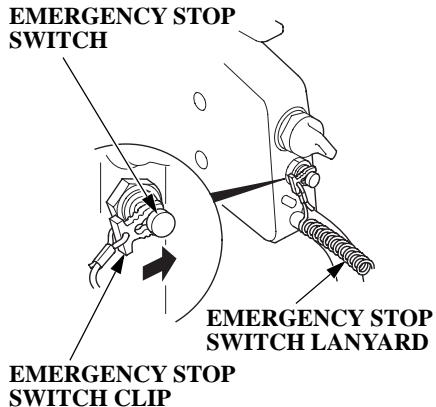

1. Put the emergency stop switch clip in the emergency stop switch, and attach the emergency stop switch lanyard securely to the operator or to the operator's PFD (Personal Flotation Device).

The engine will not start or run, unless the emergency stop switch clip is in the emergency stop switch.

The emergency stop switch clip and emergency stop switch lanyard system is a safety device that will stop the engine if you fall away from the controls while operating the boat.

Always attach the emergency stop switch lanyard securely to the operator or to the operator's PFD before starting the engine.

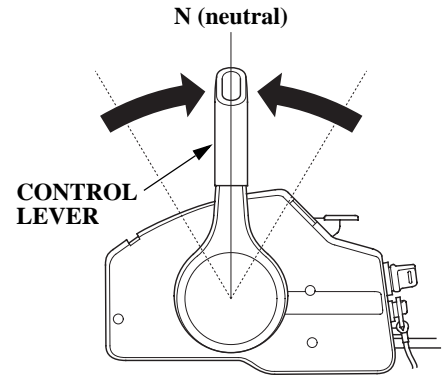

2. Set the control lever in the N (neutral) position.

The engine will not start if the F (forward) or R (reverse) gears are engaged.

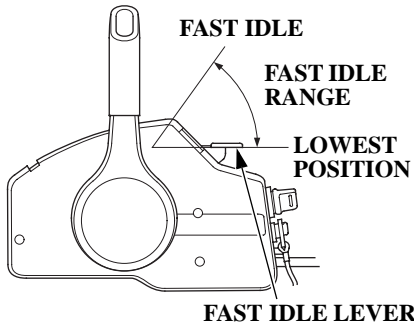

3. To start a cold engine, leave the fast idle lever in the OFF (fully lowered) position.

To restart a warm engine, raise the fast idle lever.

The fast idle lever cannot be raised unless the control lever is in the N (neutral) position.

The control lever cannot be moved away from the N (neutral) position unless the fast idle lever is lowered.

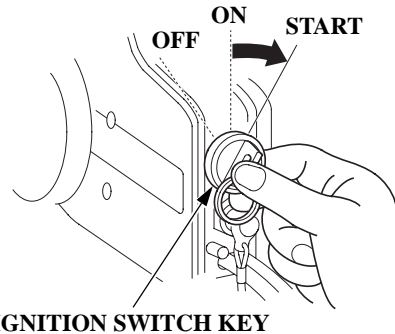

4. Turn the ignition switch key to the START position and hold it there until the engine starts.

When the engine starts, release the key, allowing it to return to the ON position.

If the engine fails to start within 5 seconds, release the key and wait at least 10 seconds before operating the starter again.

NOTICE

- Using the electric starter for more than 5 seconds at a time will overheat the starter motor and can damage it.
- Turning the ignition switch key to the START position while the engine is running can damage the starter motor and flywheel.

OPERATION

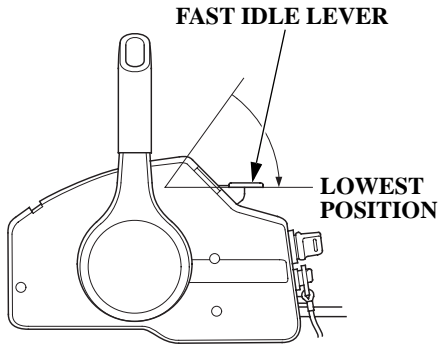

5. If the fast idle lever was used to start the engine, gradually lower the lever as the engine warms up.

When the fast idle lever is fully lowered, the control lever can be moved away from the N (neutral) position.

6. Before getting underway, allow the engine to warm-up sufficiently to ensure good performance.

Above 41°F (5°C), warm-up the engine for 2 or 3 minutes.

Below 41°F (5°C), warm up the engine for at least 10 minutes at 2,000 rpm.

During the warm-up period, check the oil pressure indicator (p. 33), overheat indicator (p. 33), and cooling system indicator (p. 34).

If the indicators show any abnormal condition, immediately stop the engine and determine the cause of the problem. Refer to *TAKING CARE OF UNEXPECTED PROBLEMS*, p. 106.

EMERGENCY STARTING

If the battery is discharged, or the starter motor and the recoil starter are inoperative, you can start the engine manually using the emergency starter rope that came with your outboard motor.

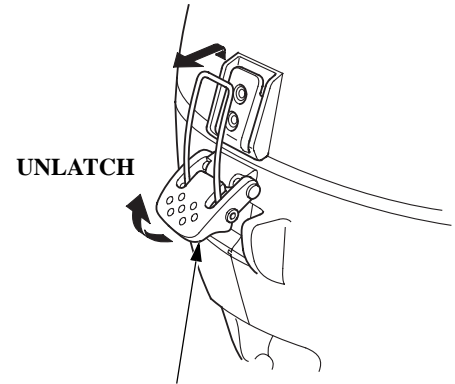

ENGINE COVER LATCH

1. Unlatch and remove the engine cover (p. 74).

NEUTRAL START CABLE

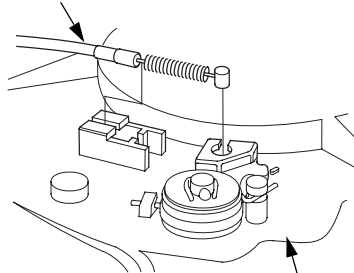

RECOIL STARTER ASSEMBLY

2. Move the shift lever to the F (forward) position. Loosen the neutral start cable lock nut and disconnect the neutral start cable.

FLANGE BOLT

RECOIL STARTER ASSEMBLY

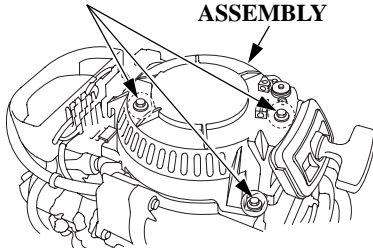

3. Unscrew the three flange bolts and remove the recoil starter assembly.

4. Set the controls the same as for normal starting (see pages 49 – 54). Use the choke and fast idle controls if needed.

Electric start type:

Turn the ignition switch key to the ON position.

5. Set the knotted end of the emergency starter rope in the notch in the flywheel pulley. Wind the rope clockwise around the flywheel pulley, as shown.

FLYWHEEL PULLEY (STARTER PULLEY)

STARTER ROPE

KNOT

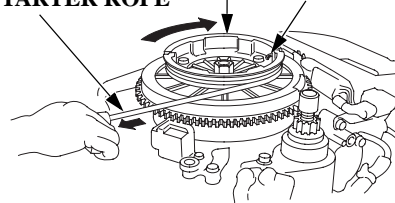

6. Pull the emergency starter rope slowly until resistance is felt, then pull briskly.

Keep away from moving parts while pulling the rope.

If necessary, rewind the rope and pull again. If the engine does not start after several attempts, refer to *TAKING CARE OF UNEXPECTED PROBLEMS*, p. 100.

⚠ WARNING

Exposed moving parts can cause injury.

- Do not operate the outboard motor without the engine cover.
- Use extreme care when installing the engine cover.

OPERATION

7. If the choke and fast idle control(s) were used to start the engine, return the control(s) to the normal operating position as the engine warms up.

During the warm-up period, check the oil pressure indicator (p. 33), overheat indicator (p. 33), and cooling system indicator (p. 34).

8. Leave the recoil starter assembly off, but install the engine cover (p. 74), and lock it in place by latching the engine cover latch.

9. If it was necessary to remove the emergency stop switch lanyard from you to perform the emergency starting procedure, be sure the lanyard is attached securely to operator before operating the outboard motor.

10. Have your closest authorized Honda Marine dealer check your electrical system and correct the problem so that you can use the electric starter.

The recoil starter assembly (p. 55) should be reinstalled after the electric starter is working again. Install the recoil starter assembly with the engine stopped.

STOPPING THE ENGINE

Emergency Engine Stopping

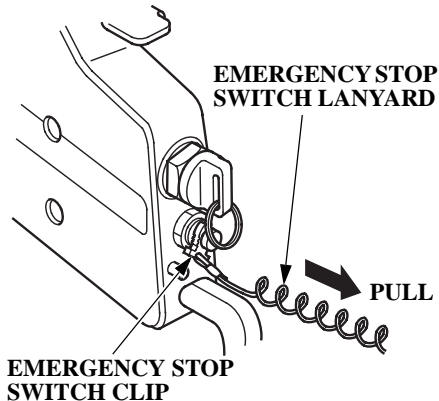
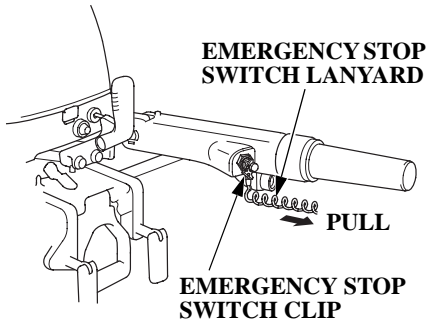

To stop the engine in an emergency, pull the emergency stop switch clip out of the engine or emergency stop switch by pulling the emergency stop switch lanyard.

We suggest that you stop the engine this way occasionally to verify that the engine and emergency stop switch are operating properly.

Turn the ignition switch key to the OFF position (electric start type) after verifying the engine or emergency stop switch operation.

Normal Engine Stopping

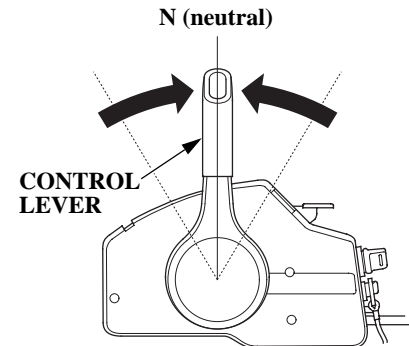
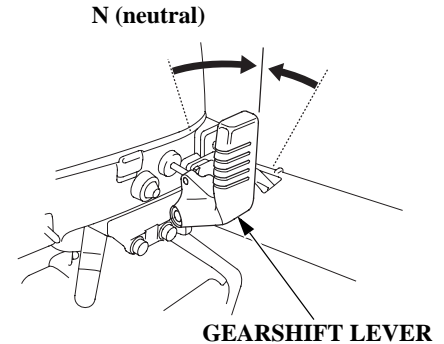
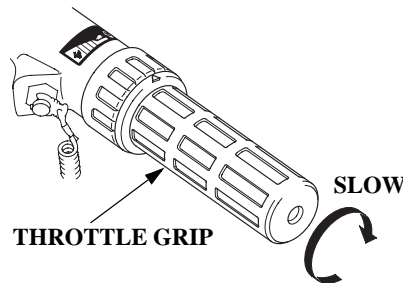

1. Move the throttle grip to the slowest position and the gearshift lever or the remote control lever to the N (neutral) position.

OPERATION

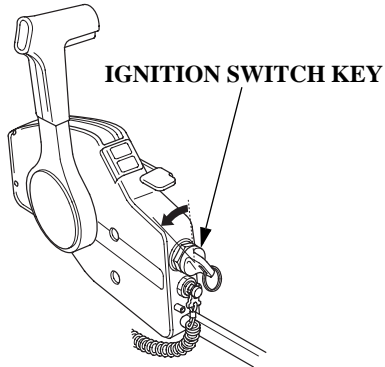
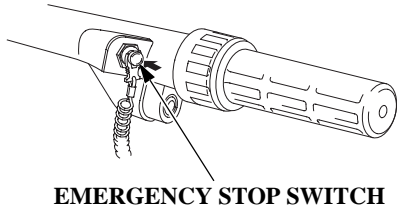

After cruising at full throttle, cool down the engine by idling for a few minutes before stopping the engine.

2. Turn the ignition switch key to the OFF position or press the emergency stop switch until the engine stops.
3. When the boat is not in use, remove and store the ignition switch key and the emergency stop switch clip and lanyard. If you are using a portable fuel tank, disconnect the fuel hose if you will be storing or transporting the outboard motor.

GEARSHIFT AND THROTTLE OPERATION

H Type (tiller handle)

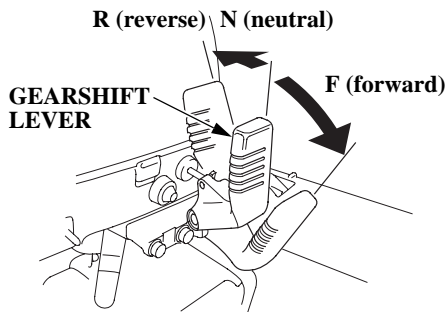
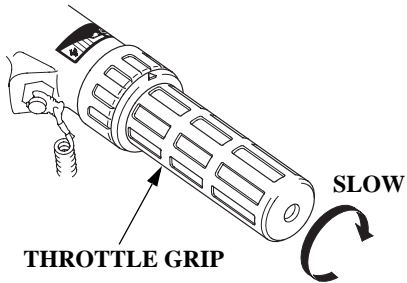

To shift gears, turn the throttle grip to the SLOW position; then move the gearshift lever to select the F (forward), N (neutral), or R (reverse) gears.

The engine can be started with the gearshift lever in the N (neutral) position only.

The throttle grip can be turned to the FAST position only when the gearshift lever is in the F (forward) position.

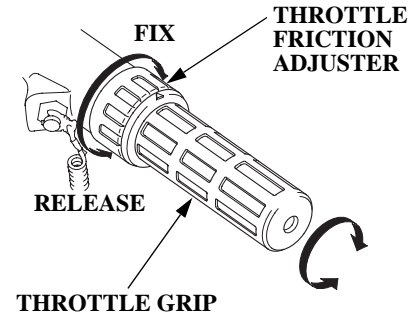

Use the throttle friction adjuster to help hold a constant throttle setting while cruising.

Turn the adjuster clockwise to increase throttle grip friction for holding a constant speed.

Turn the adjuster counterclockwise to decrease friction for easy grip rotation.

OPERATION

R Type (remote control)

CONTROL
LEVER

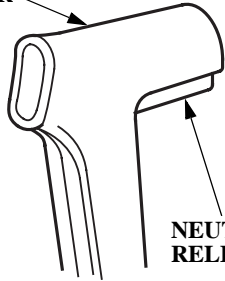

NEUTRAL
RELEASE LEVER

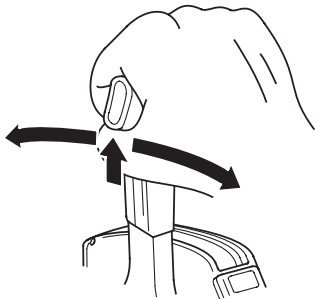

To shift gears, move the control lever to select the F (forward), N (neutral), or R (reverse) gear.

The control lever cannot be moved from the N (neutral) position unless the neutral release lever is squeezed.

Moving the control lever beyond the gear selection range increases engine speed.

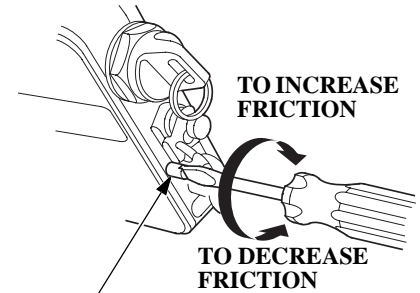

REMOTE CONTROL
FRICTION ADJUSTER

Adjust the remote control friction adjuster so the control lever will hold a constant throttle setting while cruising.

STEERING

H Type (tiller handle)

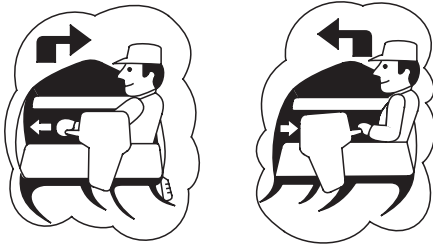

Steer by moving the tiller handle opposite the direction you want the boat to turn.

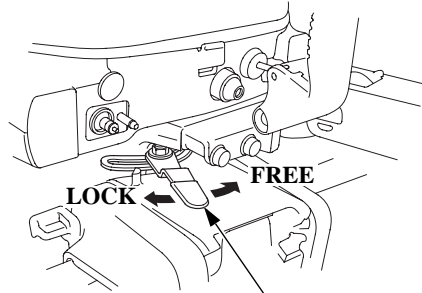

STEERING FRICTION LEVER

Use the steering friction lever to help hold a steady course while cruising.

Move the lever to the **LOCK** direction to increase steering friction for holding a steady course and for trailering.

Move the lever to the **FREE** direction to decrease friction for easy turning.

R Type (remote control)

Steer the boat in the same manner as an automobile.

OPERATION

CRUISING

Engine Speed

For best fuel economy, limit the throttle opening to 80%. Use the throttle friction control (p. 59 or p. 60) to help you hold a steady speed.

For rough water conditions or large waves, slow down to prevent the propeller from rising out of the water.

Transom Angle

Install the outboard motor at the best transom angle for stable cruising and maximum power. See page 46 for adjustment procedure.

Transom angle too large: Causes boat to “squat.”

Transom angle too small: Causes boat to “bow steer” (sprayed water may enter the boat).

It is necessary to adjust the transom angle of the outboard motor to compensate for changes in boat load, weight distribution, water conditions, or propeller selection.

Under normal running conditions, the boat will perform best when the antiventilation plate is level with the water surface.

When cruising into a high wind, adjust the outboard motor down slightly to level the boat and improve stability. With a tail wind, adjust the outboard motor up slightly (p. 46).

NOTICE

Excessive trim/tilt angle during operation can cause propeller ventilation, overheating, and water pump damage. This type of damage is not covered by the Distributor’s Limited Warranty (p. 128).

**OUTBOARD
MOTOR ANGLE
ADJUSTED TOO
LOW**

**OUTBOARD
MOTOR ANGLE
ADJUSTED TOO
HIGH**

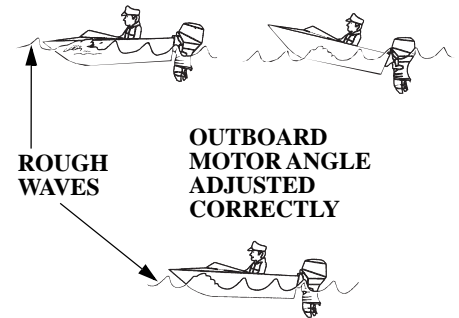

BOW TOO LOW DUE TO
1. LOAD IN THE FRONT
2. OUTBOARD MOTOR ANGLE
ADJUSTED TOO LOW

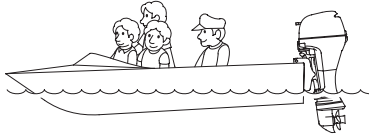

BOW TOO HIGH DUE TO
1. LOAD IN THE REAR
2. OUTBOARD MOTOR ANGLE
ADJUSTED TOO HIGH

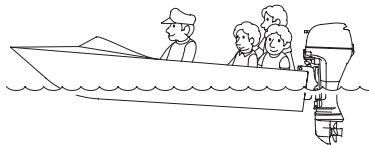

Outboard Motor Angle (Cruising)

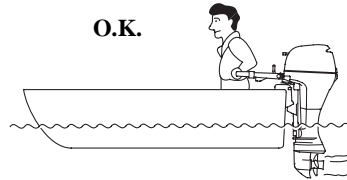

CORRECT
GIVES MAXIMUM PERFORMANCE

OPERATION

SHALLOW WATER OPERATION

Manual tilt Type

When operating in shallow water, tilt the outboard motor, using the tilt lever, so the propeller and gear case won't hit the bottom.

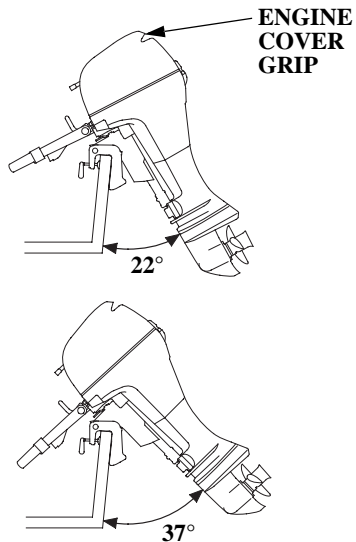

To tilt the outboard motor, move the tilt lever to the TILT position, then raise the outboard motor to the 22° or 37° position by pulling on the engine cover grip.

NOTICE

Do not use the tiller handle as a lever to raise the outboard motor. Applying excessive force to the tiller handle can damage it.

While the outboard motor is tilted, proceed at a low speed, and do not operate the outboard motor in reverse.

The outboard motor will rise suddenly if operated in reverse.

Monitor water flow from the cooling system indicator (p. 34) to be sure the outboard motor is not tilted so high that the water intakes are out of the water.

NOTICE

An excessive trim/tilt angle during operation can cause propeller ventilation, overheating, and water pump damage. This type of damage is not covered by the Distributor's Limited Warranty (p. 128).

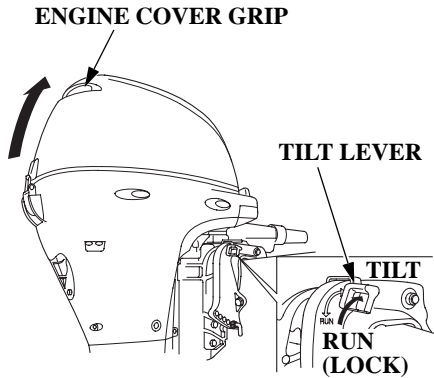

To return the outboard motor to the normal operating position, move the tilt lever to the LOCK (RUN) position. You may need to raise the outboard motor slightly to disengage the tilt mechanism, and then slowly lower the outboard motor.

T Type

When operating in shallow water, use the power tilt switch to tilt the outboard motor, so the propeller and gear case won't hit the bottom.

Proceed at low speed, and monitor water flow from the cooling system indicator (p. 34) to be sure the outboard motor is not tilted so high that the water intakes are out of the water.

NOTICE

An excessive trim/tilt angle during operation can cause propeller ventilation, overheating, and water pump damage. This type of damage is not covered by the Distributor's Limited Warranty (p. 128).

G Type

When operating in shallow water, tilt the outboard motor, using the tilt lever, so the propeller and gear case won't hit the bottom.

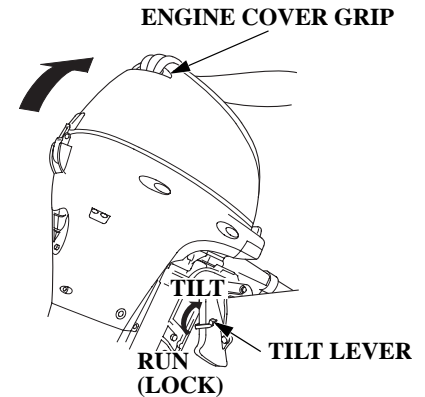

To tilt the outboard motor, move the tilt lever to the TILT position, then raise the outboard motor to the desired position by pulling on the engine cover grip.

OPERATION

NOTICE

Do not use the tiller handle as a lever to raise the outboard motor.

Applying excessive force to the tiller handle can damage it.

While the outboard motor is tilted, proceed at a low speed, and do not operate the outboard motor in reverse.

The outboard motor will rise suddenly if operated in reverse.

Monitor water flow from the cooling system indicator (p. 34) to be sure the outboard motor is not tilted so high that the water intake is out of the water.

NOTICE

An excessive tilt angle during operation can cause propeller ventilation, overheating, and water pump damage. This type of damage is not covered by the Distributor's Limited Warranty (p. 128).

To return the outboard motor to the normal operating position, move the tilt lever to the RUN (LOCK) position. You may need to raise the outboard motor slightly to disengage the tilt mechanism, then slowly lower the outboard motor.

MOORING, BEACHING, LAUNCHING

Before tilting up, leave the outboard motor in the running position for one minute after stopping the engine to drain the water from inside the engine.

Stop the engine and disconnect the fuel hose from the outboard motor before tilting the outboard motor.

Manual tilt Type

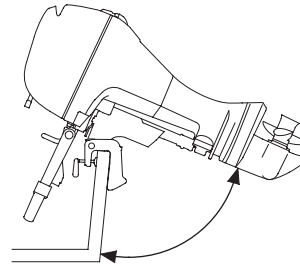

63° or 64° (when mooring)

To raise the outboard motor out of the water while the boat is moored, or for maximum clearance when beaching or launching, tilt the outboard motor to the 63° or 64° position.

Stop the engine before tilting the outboard motor. The 63° or 64° position is not an operating position.

Raise and lower the outboard motor as described on p. 64.

G Type

Use the tilt lever to raise and lower the outboard motor as described on p. 65.

G and T Types

To raise the outboard motor out of the water while the engine is stopped and the boat is moored, or for maximum clearance when beaching or launching, use the power tilt switch (T type) to tilt the outboard motor as far as it will go, move the tilt lock lever to the LOCK position, then gently lower the outboard motor until the lever contacts the stern bracket.

If more clearance is needed to swing the tilt lock lever into the LOCK position, rock the outboard motor forward slightly by pulling on the engine cover grip.

OPERATION

To lower the outboard motor, tilt up, move the tilt lock lever to the FREE position, and then lower the outboard motor to the desired position.

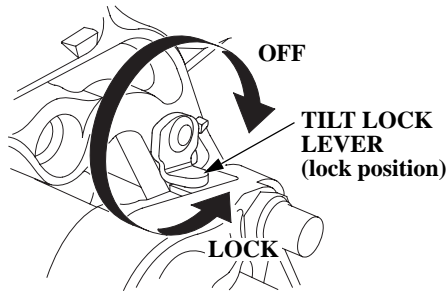

NOTICE

Do not attempt to use the power tilt switch to tilt the outboard motor down while the tilt lock lever is in the LOCK position. Damage to the power tilt system may occur.

T Type

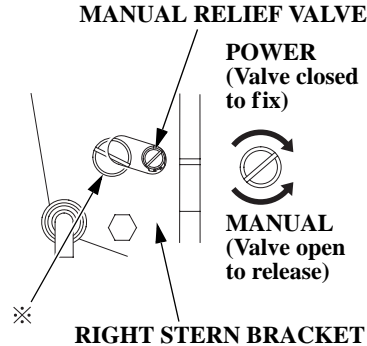

※: Do not turn this screw. If this screw is turned hydraulic oil will bleed out of the power tilt system. Should this happen it will be necessary to consult your authorized Honda Marine dealer and have the system refilled.

The outboard motor can also be tilted manually after opening the manual relief valve. This feature enables the outboard motor to be tilted when no battery is connected.

For manual tilting, use a flat blade screwdriver to turn the valve counterclockwise 2 and a half turns. Close the valve firmly after positioning the engine.

Be sure the valve is closed before operating the outboard motor. If the valve is not closed, the outboard motor will tilt up when operated in reverse.

SERVICING YOUR OUTBOARD MOTOR

THE IMPORTANCE OF MAINTENANCE

Proper maintenance is essential for safe, economical, and trouble-free operation. It will also help reduce air pollution.

WARNING

Improperly maintaining this outboard motor or failure to correct a problem before operation can cause a malfunction in which you could be seriously hurt or killed.

Always follow the inspection and maintenance recommendations and schedules in this Owner's Manual.

To help you properly care for your outboard motor, the following pages include a maintenance schedule, routine inspection procedures, and simple maintenance procedures using basic hand tools. Other service tasks that are more difficult or require special tools are best handled by professionals and are normally performed by a Honda technician or other qualified mechanic.

The maintenance schedule applies to normal operating conditions. If you operate your outboard motor under unusual conditions, consult an authorized Honda Marine dealer for recommendations applicable to your individual needs and use.

Honda will not deny a claim for warranty coverage simply because you did not maintain your outboard. However, any part that fails due to lack of maintenance, or improper maintenance will not be covered under your product warranty.

Remember that your authorized Honda Marine dealer knows your outboard motor best and is fully equipped to maintain and repair it.

To ensure the best quality and reliability, use only new, Honda Genuine parts or their equivalents for repair and replacement.

Maintenance, replacement, or repair of the emission control devices and systems may be performed by any marine engine repair establishment or individual, using parts that are “certified” to EPA standards.

SERVICING YOUR OUTBOARD MOTOR

MAINTENANCE SAFETY

Some of the most important safety precautions follow. However, we cannot warn you of every conceivable hazard that can arise in performing maintenance. Only you can decide whether or not you should perform a given task.

WARNING

Failure to properly follow maintenance instructions and precautions can cause you to be seriously hurt or killed.

Always follow the procedures and precautions in the Owner's Manual.

Safety Precautions

- Make sure the engine is off before you begin any maintenance or repairs. This will eliminate several potential hazards:
 - **Carbon monoxide poisoning from engine exhaust.**
Do not start or run the engine in a confined or partly enclosed area.
 - **Burns from hot parts.**
Let the engine and exhaust system cool before touching.
 - **Injury from moving parts.**
Do not run the engine unless instructed to do so.
- Read the instructions before you begin, and make sure you have the tools and skills required.
- To reduce the possibility of fire or explosion, be careful when working around gasoline. Use only a nonflammable solvent, not gasoline, to clean parts. Keep cigarettes, sparks, and flames away from all fuel-related parts.
- Wear gloves when handling the propeller to protect your hands from sharp edges.

SERVICING YOUR OUTBOARD MOTOR

TOOL KIT AND EMERGENCY STARTER ROPE

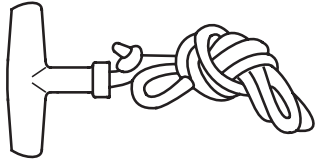

EMERGENCY STARTER ROPE

The following tools are supplied with the outboard motor for simple maintenance procedures and emergency repairs. An emergency starter rope is also supplied. Keep these items on the boat so that they will always be available if you need them.

If your tool kit needs replacement, it is not available as a kit and each item must be ordered individually.

TOOL KIT and OWNER'S MANUAL

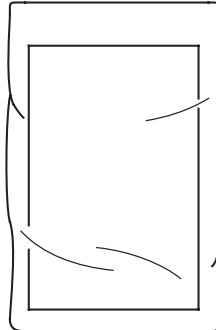

OWNER'S MANUAL



FLAT SCREWDRIVER



SPARK PLUG WRENCH



4 mm HEX. WRENCH



10 mm SOCKET WRENCH



GRIP

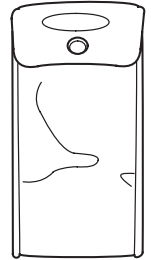

TOOL BAG

SERVICING YOUR OUTBOARD MOTOR

MAINTENANCE SCHEDULE

Follow the MAINTENANCE SCHEDULE table and service your outboard motor accordingly. Please note, a claim for warranty coverage will not be denied simply because the maintenance schedule for your outboard motor was not followed. However, any part(s) that fails specifically due to lack of maintenance, or improperly performed maintenance, would not be covered under the *Distributor's Limited Warranty*.

REGULAR SERVICE PERIOD (3) Perform at every indicated month or operating hour interval, whichever comes first.		Each use	After use	First month or 20 hrs.	Every 6 months or 100 hrs.	Every year or 200 hrs.	Every 2year or 400 hrs.
ITEM							
Engine oil	Check level	o					
	Change			o	o		
Gear case oil	Change			o	o		
Timing belt	Check					o (2)	
Engine oil filter	Replace					o (2)	
Starter rope	Check				o		
Carburetor linkage	Check-adjust			o (2)	o (2)		
Idling speed	Check-adjust			o (2)	o (2)		
Valve clearance	Check-adjust					o (2)	
Spark plug	Check-adjust/Replace				o		
Propeller and cotter pin	Check	o					
Anode metal (Outside engine)	Check	o					
Anode metal (Inside engine)	Check						o (2) (6)
Lubrication	Grease			o (1)	o (1)		
Fuel tank and tank filter	Clean					o	

- (1) Lubricate more frequently when used in salt water.
- (2) These items should be serviced by your servicing dealer, unless you have the proper tools and are mechanically proficient. Refer to the Honda shop manual for service procedures.
- (3) For professional commercial use, log hours of operation to determine proper maintenance intervals.
- (4) When operating in salt water, turbid or muddy water, the engine should be flushed with clean water after each use.
- (5) Upon starting, check for unusual engine sounds and cooling water flowing freely from the check hole.
- (6) Replace the anodes when they have been reduced to about two-thirds of their original size, or if they are crumbling.

SERVICING YOUR OUTBOARD MOTOR

REGULAR SERVICE PERIOD (3) Perform at every indicated month or operating hour interval, whichever comes first.		Each use	After use	First month or 20 hrs.	Every 6 months or 100 hrs.	Every year or 200 hrs.	Every 2year or 400 hrs.
ITEM							
Fuel filter	Check				o		
	Replace					o	
Thermostat	Check					o (2)	
Fuel line	Check	o (7)					
	Replace		Every 2 years (if necessary) (2) (8)				
Battery and cable connection	Check level-tightness	o					
Bolts and nuts	Check-tightness			o (2)	o (2)		
Crankcase breather tube	Check					o (2)	
Cooling water passages	Clean		o (4)				
Water pump	Check					o (2)	
Emergency stop switch	Check	o					
Engine oil leak	Check	o					
Each operation part	Check	o					
Engine condition (5)	Check	o					
Power Trim/Tilt	Check				o (2)		
Shift Cable	Check-adjust				o (2)		

- (1) Lubricate more frequently when used in salt water.
- (2) These items should be serviced by your servicing dealer, unless you have the proper tools and are mechanically proficient. Refer to the Honda shop manual for service procedures.
- (3) For professional commercial use, log hours of operation to determine proper maintenance intervals.
- (4) When operating in salt water, turbid or muddy water, the engine should be flushed with clean water after each use.
- (5) Upon starting, check for unusual engine sounds and cooling water flowing freely from the check hole.
- (6) Replace the anodes when they have been reduced to about one third their original size, or if they are crumbling.
- (7) Check the fuel line for leaks, cracks or damage. If it is leaking, cracked or damaged, take it to your servicing dealer for replacement before using your outboard.
- (8) Check the fuel line for leaks, cracks, or damage. Replace the fuel line if there are signs of leaks, cracks or damage.

SERVICING YOUR OUTBOARD MOTOR

MANUAL RELIEF VALVE (T type)

RIGHT STERN BRACKET

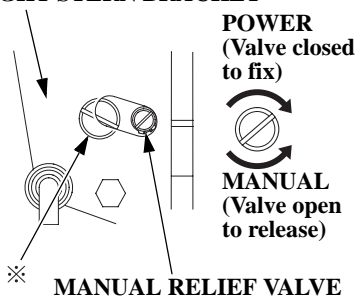

※ : Do not turn this screw. If this screw is turned hydraulic oil will bleed out of the power tilt system. Should this happen it will be necessary to consult your authorized Honda Marine dealer and have the system refilled.

The outboard motor can be tilted manually after opening the manual relief valve. This feature enables the outboard motor to be tilted when no battery is connected.

For manual tilting, use a flat blade screwdriver to turn the valve counterclockwise 2 and a half turns. Close the valve firmly after positioning the engine.

Be sure the valve is closed before operating the outboard motor. If the valve is not closed, the outboard motor will tilt up when operated in reverse.

ENGINE COVER REMOVAL AND INSTALLATION

(REAR)

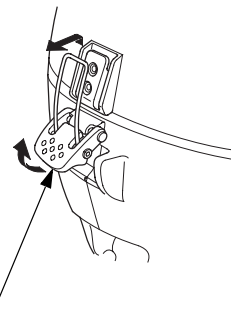

ENGINE COVER LATCH

(FRONT)

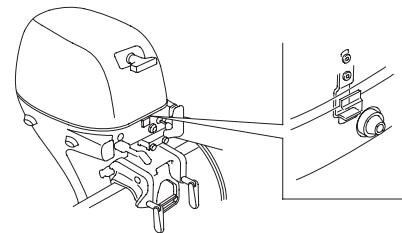

SERVICING YOUR OUTBOARD MOTOR

(INSTALLATION)

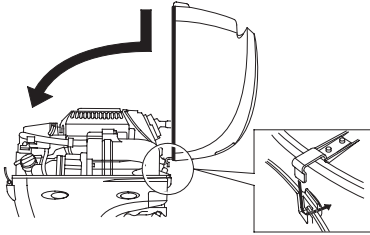

The engine cover latch fastens the engine cover to the outboard motor.

To remove the engine cover, unlatch the engine cover latch, then lift the engine cover off the outboard motor.

To install the engine cover, place the cover on the outboard motor, then latch the engine cover latch securely.

Engine Oil Level Check

Check the engine oil level with the engine stopped and the outboard motor in the vertical position.

1. Unlatch and remove the engine cover.
2. Remove the dipstick and wipe it clean.

OIL LEVEL DIPSTICK

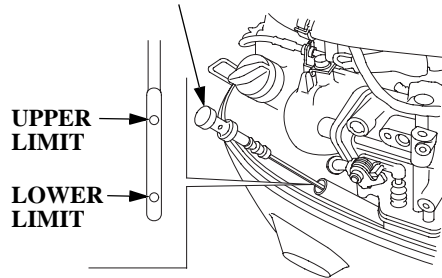

3. Insert the dipstick all the way in, then remove it and check the oil level shown on the dipstick.

OIL FILLER CAP

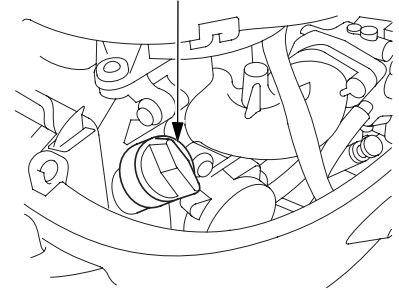

4. If the oil level is low, remove the oil filler cap, and add oil to reach the upper limit mark shown on the dipstick. Use the oil recommended on p. 79.

NOTICE

Running the engine with a low oil level can cause engine damage.

5. Install the oil filler cap and tighten it securely.
6. Install and lock the engine cover.

SERVICING YOUR OUTBOARD MOTOR

When you check the oil level with the dipstick, you might notice the engine oil appears milky or the oil level has increased. If you notice either condition, change the engine oil. See the following table for an explanation of these conditions.

Operating Method	Result	Effect
Running the engine below 3,000 rpm for more than 30% of the time so the engine does not warm up.	<ul style="list-style-type: none">• Water condenses in the engine and mixes with the oil, resulting in a milky appearance.	The engine oil deteriorates, becomes less efficient as a lubricant, and causes an engine malfunction.
Frequent starting and stopping without allowing the engine to warm up.	<ul style="list-style-type: none">• Unburned fuel mixes with the oil, increasing the volume of oil.	

Engine Oil Change

An engine oil evacuation device may be used to remove the engine oil.

Drain the used oil while the engine is warm. Warm oil drains quickly and completely.

1. Unlatch and remove the engine cover (p. 74).

SERVICING YOUR OUTBOARD MOTOR

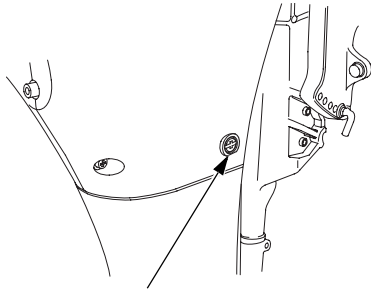

ENGINE OIL DRAIN SCREW

2. Remove the oil filler cap, and place a suitable container below the drain screw hole to catch the used oil, then remove the engine oil drain screw.
3. Allow the used oil to drain completely, then reinstall the engine oil drain screw, and tighten it securely.

Inspect the sealing O-ring and replace if damaged or torn.

NOTICE

Improper disposal of engine oil can be harmful to the environment. If you change your own oil, please dispose of the used oil properly. Put it in a sealed container, and take it to a recycling center. Do not discard it in a trash bin, dump it on the ground, or pour it down a drain.

4. With the outboard motor in a vertical position, fill to the upper limit mark on the dipstick (p. 75) with the recommended oil.

Engine oil refill capacity:

Without oil filter change:

1.1 US qt (1.0 L)

With oil filter change:

1.2 US qt (1.1 L)

5. Install the oil filler cap and tighten it securely.
6. Install and lock the engine cover.

SERVICING YOUR OUTBOARD MOTOR

Oil Filter Change

1. Drain the engine oil, and reinstall the drain screw (see Engine Oil Change on p. 76).
2. Unscrew the six bolts and remove the R. engine under cover.
3. Use a suitable tool to remove the oil filter, and thoroughly drain the filter into the used oil container.

USE A SUITABLE TOOL

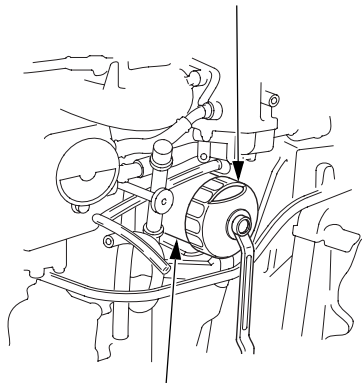

OIL FILTER

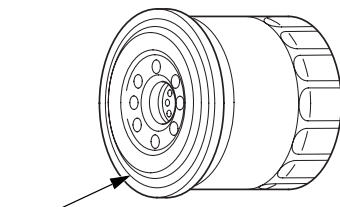

RUBBER SEAL

4. Clean the oil filter mounting base, and coat the rubber seal of the new oil filter with clean engine oil.

NOTICE

Use only a Honda Genuine oil filter or a filter of equivalent quality specified for your model. Using the wrong filter, or a non-Honda filter which is not of equivalent quality, may cause engine damage.

5. Screw on the new filter by hand until it contacts the engine, then use a suitable tool to tighten the filter an additional 7/8 turn.

OIL FILTER TIGHTENING TORQUE:

9 lbf·ft (12 N·m, 1.2 kgf·m)

6. Fill the crankcase with the specified amount (p. 76) of the recommended oil.
7. Start the engine and check for leaks.

NOTICE

Running the engine without water can cause serious engine damage. If you are changing the oil filter while the outboard motor is out of the water, place the unit in water or supply adequate water to the water intakes before running the engine. Do not run the engine with the flush attachment on the power head.

8. Stop the engine, and check the oil level as described on page 75. If necessary, add oil to bring the oil level to the upper limit mark on the dipstick.

SERVICING YOUR OUTBOARD MOTOR

Engine Oil Recommendations

Oil is a major factor affecting performance and service life. Use 4-stroke detergent oil.

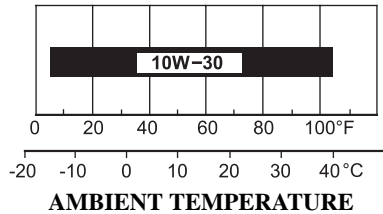

Honda 10W-30 FC-W[®] outboard motor oil is recommended for general use.

FC-W[®] is a registered trademark of the National Marine Manufacturers Association.

If Honda 10W-30 FC-W oil is not available, Honda recommends that you use API service category SG, SH or SJ oil. The SAE oil viscosity and service category are in the API label on the oil container.

Gear Case Oil Level Check

Check the gear case oil level with the engine stopped and the outboard motor in the vertical position.

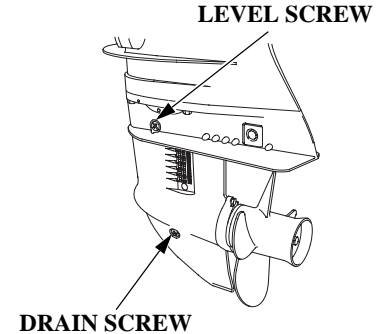

Remove the oil level screw and see whether oil flows from the oil level hole.

If oil flows from the oil level hole, the oil level is OK. Reinstall the screw and tighten it securely.

OIL LEVEL SCREW TORQUE:
4.8 lbf·ft (6.5 N·m, 0.66 kgf·m)

SERVICING YOUR OUTBOARD MOTOR

If no oil flows from the oil level hole, add the recommended oil (p. 81) following the procedure described in Gear Case Oil Change.

Gear Case Oil Change

Change the gear case oil with the engine stopped and the outboard motor in the vertical position.

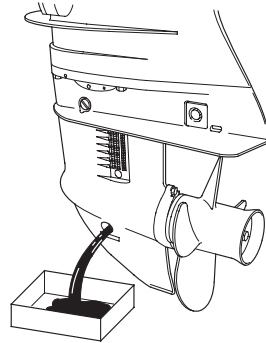

1. Place a suitable container below the oil drain hole to catch the used oil, then remove the oil level screw and oil drain screw.

2. Allow the used oil to drain completely, then install an oil pump adapter in the oil drain hole.

If water or contaminated (milky-colored) oil flows out the drain hole when the screw is removed, have the outboard motor checked by an authorized Honda Marine dealer.

SERVICING YOUR OUTBOARD MOTOR

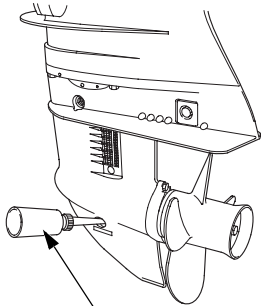

GEAR OIL BOTTLE

3. Add oil through the oil drain hole until it flows out the oil level hole, then install the oil level screw and the oil drain screw.

GEAR CASE OIL CAPACITY:
0.31 US qt (0.29 L)

Outboard motor SAE 90 hypoid
gear oil API Service category
(GL- 4)

OIL LEVEL SCREW TORQUE:
4.8 lbf·ft (6.5 N·m, 0.66 kgf·m)

Avoid losing more than 1 fl oz
(30 cm³) while reinstalling the
drain screw.

OIL DRAIN SCREW TORQUE:
4.8 lbf·ft (6.5 N·m, 0.66 kgf·m)

SERVICING YOUR OUTBOARD MOTOR

Lubrication Points

Apply Honda Marine waterproof grease to the parts shown below:

Lubrication interval:

20 operating hours or one month after the date of purchase or the initial use, then every 100 hours or 6 months (refer to the maintenance schedule on page 72).

NOTICE

To prevent corrosion, apply anticorrosion oil to pivot surfaces where grease cannot penetrate.

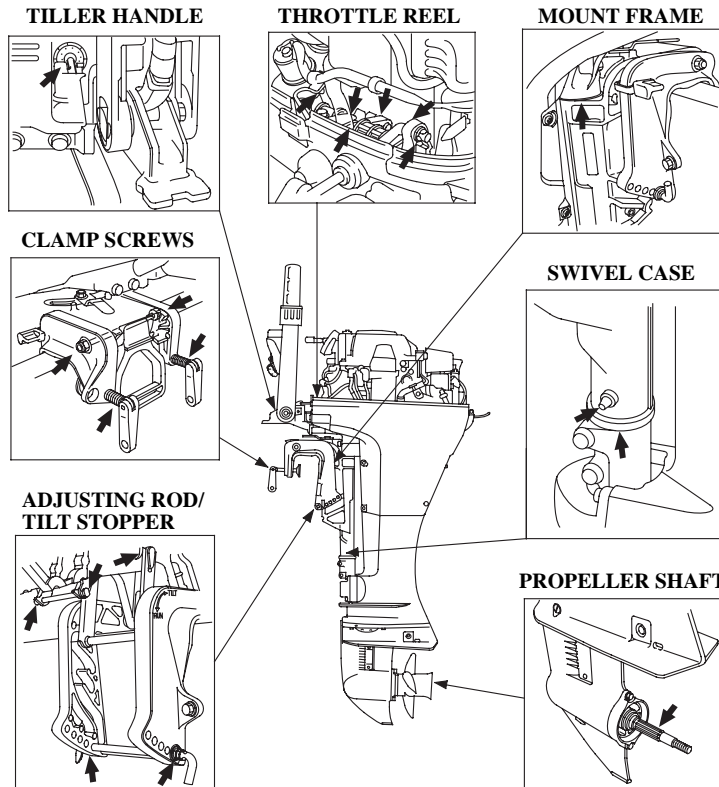
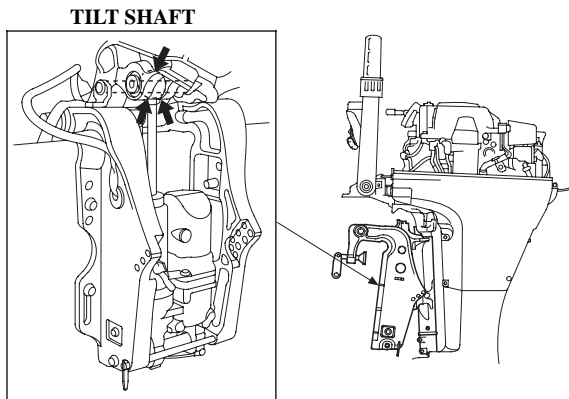

Apply Honda Marine Corrosion Inhibitor (or equivalent) to all areas under the engine cover and any exposed metal surfaces except the belts.

SERVICING YOUR OUTBOARD MOTOR

Spark Plug Service

RECOMMENDED SPARK PLUGS:
CR5EH-9 (NGK)
U16FER9 (DENSO)

NOTICE

Incorrect spark plugs can cause engine damage.

SPARK PLUG WRENCH SPARK PLUG CAP

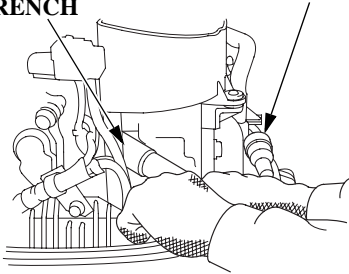

1. Unlatch and remove the engine cover (p. 74).
2. Disconnect the spark plug caps from the spark plugs.
3. Remove the spark plugs with a spark plug wrench.

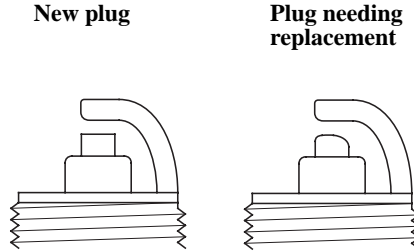

4. Inspect the spark plugs. Replace them if the electrodes are worn, or if the insulators are cracked or chipped.

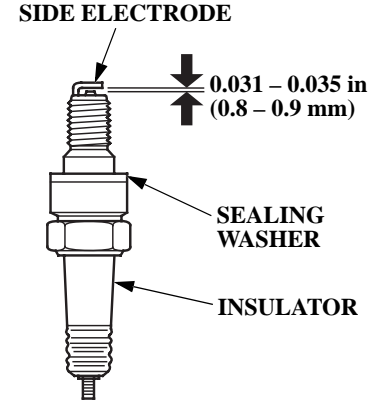

5. Measure the spark plug electrode gap with a wire-type feeler gauge. Correct the gap, if necessary, by carefully bending the side electrode.

The gap should be:
0.031 - 0.035 in (0.8 - 0.9 mm)

SERVICING YOUR OUTBOARD MOTOR

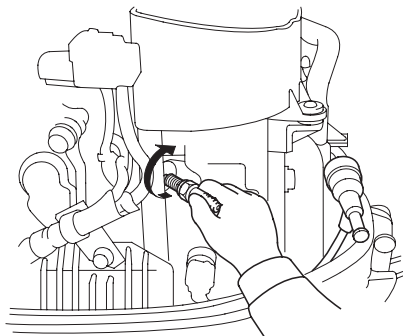

6. Install the spark plugs carefully, by hand, to avoid cross-threading.

7. After each spark plug seats, tighten with the spark plug wrench to compress the sealing washer.

If reinstalling the used spark plug, tighten $1/8 - 1/4$ turn after the spark plug seats.

If installing new spark plugs, tighten $1/2$ turn after the spark plug seats.

NOTICE

Loose spark plugs can overheat and damage the engine.

Overtightening the spark plugs can damage the threads in the cylinder head.

8. Attach the spark plug caps.

9. Install and lock the engine cover.

REFUELING

If you do not anticipate cycling through at least one complete tank of fuel within a 30 day period, we recommend adding Honda Marine Fuel Stabilizer each time you refuel.

Portable Fuel Tank

FUEL TANK CAPACITY:
3.2 US gal (12 L)

Check the fuel gauge and refill the tank when necessary.

Remove the fuel tank from the boat for refueling.

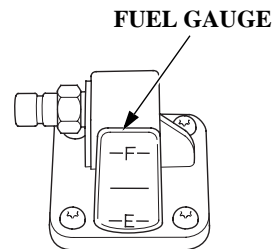

SERVICING YOUR OUTBOARD MOTOR

1. Turn the vent knob counterclockwise all the way to open the vent.

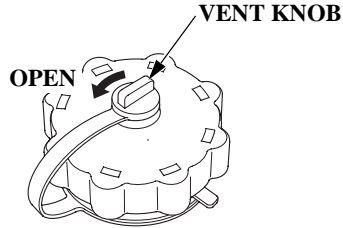

2. Turn the fuel filler cap counterclockwise so that it touches the pressure relief tab.

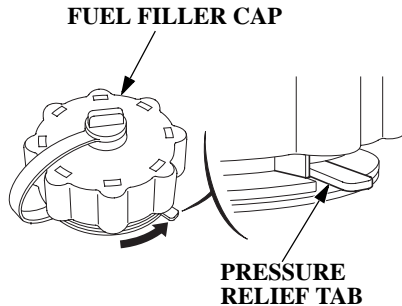

3. Press down the pressure relief tab, and then turn the fuel filler cap 1/4 counterclockwise. Release the pressure relief tab. Wait to relieve pressure.

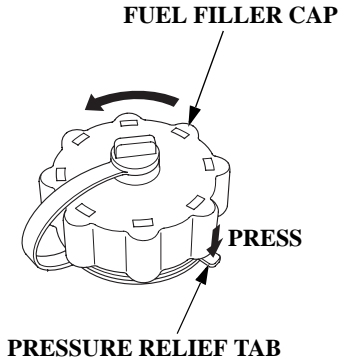

4. The fuel filler cap will lock again. Press down the pressure relief tab, and turn counterclockwise to remove the fuel filler cap.

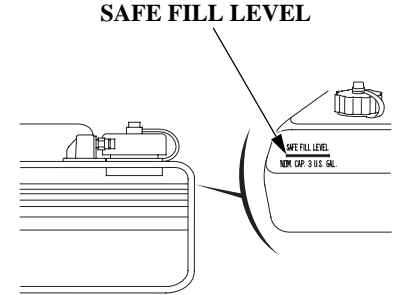

Refuel in a well-ventilated area. Fill the tank to the **SAFE FILL LEVEL** line.

After refueling, install the cap and tighten it until you hear it click. Close the vent by turning the vent knob clockwise all the way, and return the fuel tank to the boat.

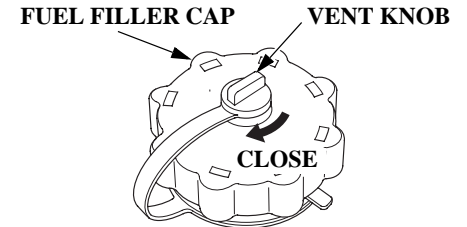

SERVICING YOUR OUTBOARD MOTOR

⚠ WARNING

Gasoline is highly flammable and explosive.

You can be burned or seriously injured when handling fuel.

- Stop the engine and keep heat, sparks, and flame away.
- Handle fuel only outdoors.
- Wipe up spills immediately.

Never refill the fuel tank inside a building where gasoline fumes may reach flames or sparks. Keep gasoline away from appliance pilot lights, barbecues, electric appliances, power tools, etc.

Spilled fuel is not only a fire hazard, it causes environmental damage.

Wipe up spills immediately.

FUEL RECOMMENDATIONS

Use unleaded gasoline with a pump octane rating of 86 or higher.

Your outboard motor is certified to operate on unleaded gasoline.

Unleaded gasoline produces fewer engine and spark plug deposits and extends exhaust system life.

Never use stale or contaminated gasoline or an oil/gasoline mixture.

Avoid getting dirt or water in the fuel tank.

You may use unleaded gasoline containing no more than 10% ethanol (E10) or 5% methanol by volume. In addition, methanol must contain cosolvents and corrosion inhibitors.

Use of fuels with content of ethanol or methanol greater than shown above may cause starting and/or performance problems. It may also damage metal, rubber, and plastic parts of the fuel system.

SERVICING YOUR OUTBOARD MOTOR

Engine damage or performance problems that result from using a fuel with percentages of ethanol or methanol greater than shown above are not covered under warranty.

If your outboard motor will be used on an infrequent or intermittent basis, please refer to the fuel section of the STORAGE chapter (p. 95) for additional information regarding fuel deterioration.

Fuel Filter Inspection and Replacement

The fuel filter is located under the engine cover, on the right side of the engine.

Water or sediment accumulation in the filter can cause loss of power or hard starting. To prevent engine malfunction, inspect the filter and replace when necessary.

⚠ WARNING

Gasoline is highly flammable and explosive.

You can be burned or seriously injured when handling fuel.

- Stop the engine and keep heat, sparks, and flame away.
- Handle fuel only outdoors.
- Wipe up spills immediately.

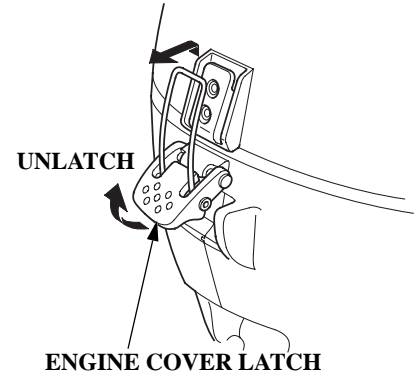

1. Unlatch and remove the engine cover for access to the fuel filter.

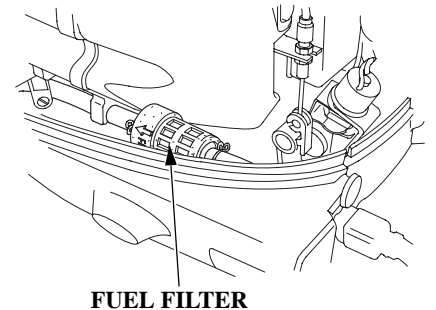

SERVICING YOUR OUTBOARD MOTOR

2. Inspect the filter for water and/or sediment accumulation.

If the filter is OK, reinstall it. If water and/or sediment are present, replace the filter as described in the following steps. Always replace the filter at the scheduled replacement interval (p. 73).

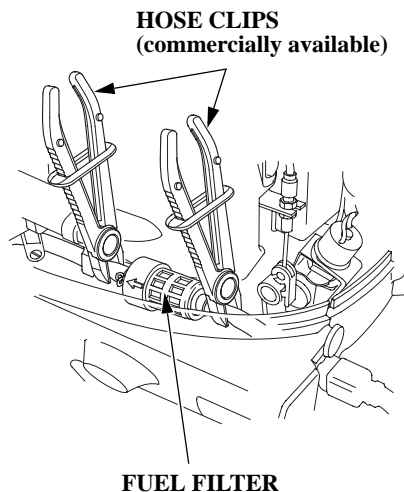

3. Disconnect the fuel hose connector from the outboard motor, and place commercially available hose clips on the fuel hoses on each side of the filter to prevent fuel leakage when the fuel hoses are disconnected.

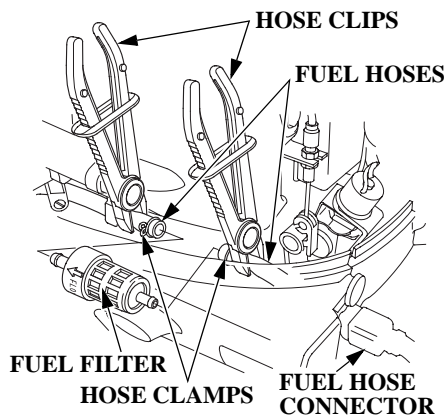

4. Remove the fuel hoses from the used filter, and discard the filter.

To ease hose removal, release the hose clamps by squeezing the clamp ends together with pliers while pulling off the hoses.

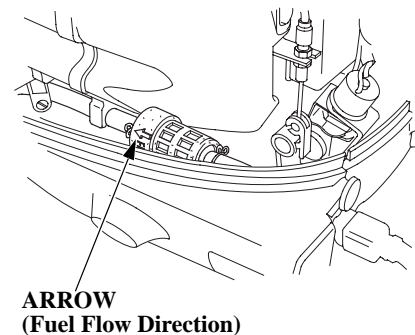

5. Install the new filter on the fuel hoses, with the fuel flow arrow pointing toward the fuel pump as shown. Fuel flow will be impeded if the filter is installed backward.
6. Remove the fuel hose clips used to close the fuel hoses, and connect the fuel hose connector to the outboard motor.

SERVICING YOUR OUTBOARD MOTOR

7. Prime the engine using the priming bulb (p. 36). Check for fuel leaks. Repair any fuel leaks if necessary.
8. Install and lock the engine cover.

Portable Fuel Tank and Tank Filter Cleaning

⚠ WARNING

Gasoline is highly flammable and explosive.

You can be burned or seriously injured when handling fuel.

- Stop the engine and keep heat, sparks, and flame away.
- Handle fuel only outdoors.
- Wipe up spills immediately.

Fuel Tank

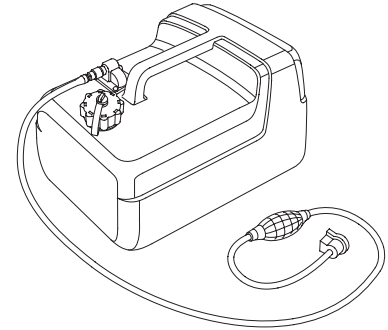

Empty the portable fuel tank into an approved gasoline container. Use a funnel to avoid spilling fuel. Rinse the fuel tank with nonflammable solvent to remove any accumulated sediment.

SERVICING YOUR OUTBOARD MOTOR

Fuel Tank Filter

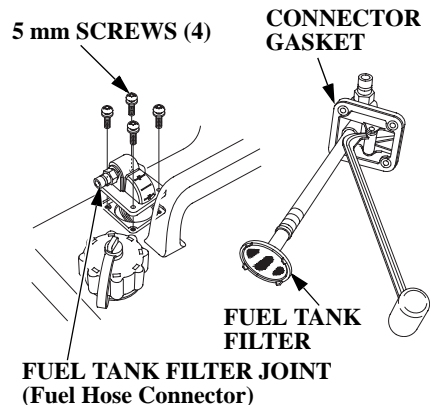

1. Remove the four 5 mm screws using a flat screwdriver, then remove the fuel hose connector and fuel tank filter from the tank.
2. Clean the filter in nonflammable solvent. Inspect the fuel tank filter and the connector gasket. Replace them if damaged.
3. Reinstall the filter and hose connector in the fuel tank. Tighten the four 5 mm screws securely.

Recoil Starter Rope Inspection

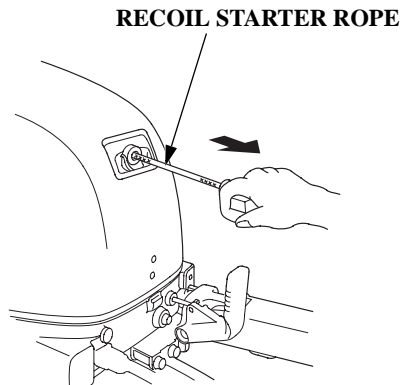

Inspect the recoil starter rope, and replace it if it becomes frayed.

Always keep the emergency starter rope on the boat in case the recoil starter rope fails.

Anode Replacement

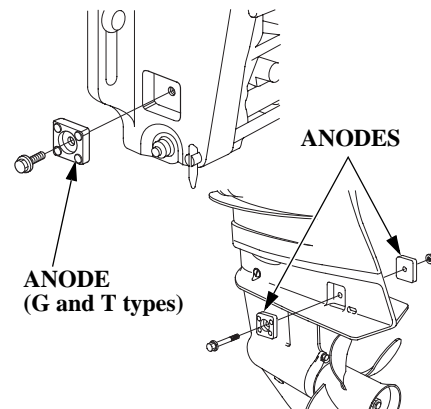

The anodes are located on each side of the gear case and the stern bracket (G and T types). They are made of a sacrificial material that helps to protect the outboard motor from corrosion.

Replace the anodes when they have been reduced to about half their original size, or if they are crumbling.

SERVICING YOUR OUTBOARD MOTOR

NOTICE

Painting or coating the anodes will defeat their purpose and will lead to rust and corrosion damage to the outboard motor. The anodes must be exposed to the water in order to protect the outboard motor.

Choke Knob Friction (manual choke type)

CHOKE KNOB

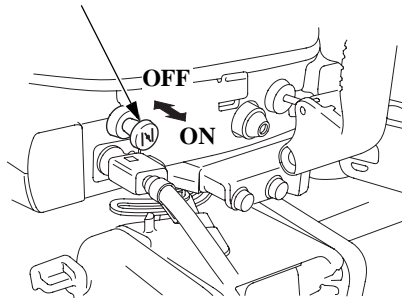

If the choke knob returns to the OFF position by itself, you can adjust the friction that holds the knob in the ON position.

FRICITION ADJUSTING NUT

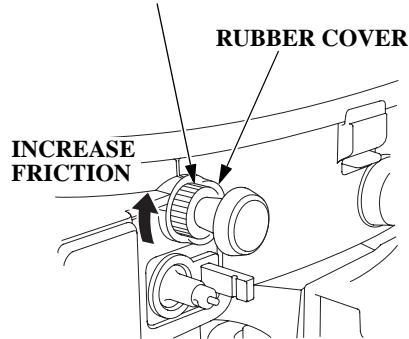

To adjust the friction, squeeze the rubber cover to grip the adjusting nut and turn it clockwise to increase the friction. Do not force the adjusting nut. If it is too hard to turn by hand, contact your Honda Marine dealer for assistance.

Propeller Replacement

Before replacing the propeller, remove the emergency stop switch clip from the emergency stop switch to prevent any possibility of the engine being started while you are working with the propeller. The propeller blades may have sharp edges, so wear heavy gloves to protect your hands.

Operating the outboard motor at higher altitudes will reduce available power. This may require decreasing the propeller pitch to maintain correct engine RPM.

Removal

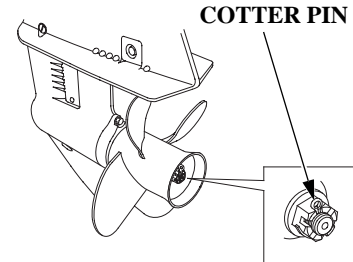

SERVICING YOUR OUTBOARD MOTOR

Remove the cotter pin, unscrew the castle nut, remove the washer, and then remove the propeller and thrust washer.

Installation

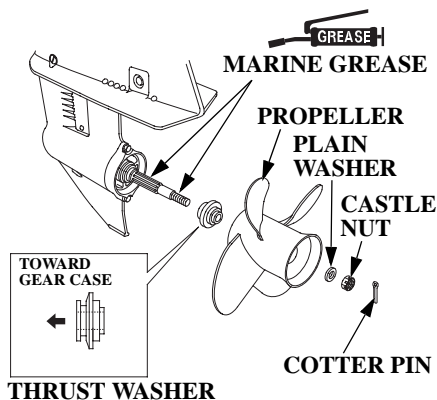

1. Apply marine grade grease to the propeller shaft.
2. Install the thrust washer with the grooved side toward the gear case.
3. Install the propeller and the plain washer.

4. Lightly tighten the castle nut by hand or wrench until the propeller has no free play.

5. Tighten the castle nut using a torque wrench.
CASTLE NUT TIGHTENING TORQUE:
2.89 lbf·ft (4 N·m)

6. Then, using a torque wrench, tighten the castle nut until the first available groove in the castle nut aligns with the cotter pin hole. Do not tighten past the first alignment of the castle nut groove and the cotter pin hole.

NOTICE

TIGHTENING TORQUE LIMIT:

12 lbf·ft (17 N·m)

Do not tighten the castle nut above the TIGHTENING TORQUE LIMIT, or the propeller and shaft may be damaged.

COTTER PIN

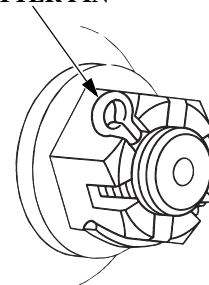

7. Be sure to replace the cotter pin with a new one.

- Use a Honda Genuine stainless steel cotter pin or equivalent cotter pin and bend the pin ends as shown.

Note that these wrenches are not included with the tool set that comes with the outboard motor. Contact your authorized Honda Marine dealer for additional tool information.

CLEANING AND FLUSHING

Cleaning and Flushing

After each use in salt water or dirty water, thoroughly clean and flush the outboard motor with fresh water. Touch up any damaged paint, and coat areas that may rust with Honda Corrosion Inhibitor, or equivalent. Lubricate controls with a silicone spray lubricant.

NOTICE

Do not apply water or corrosion inhibitor directly to the timing belt under the engine cover. If water or corrosion inhibitor penetrates the timing belt, it may be damaged. Before applying a corrosion inhibitor, cover the timing belt with a protective material to prevent damage.

Cleaning

Wash the outside of the outboard motor with clean, fresh water to remove mud, salt, seaweed, etc.

Disengage the emergency stop switch clip from the emergency stop switch, and pull the starter grip several times to expel any water remaining in the water pump.

Flushing With the Honda Garden Hose Adapter (optional equipment)

1. Disconnect the fuel hose from the outboard motor.
2. Tilt down the outboard motor.
3. Unlatch the engine cover latch and remove the engine cover (p. 74), and install the garden hose adapter.
4. Attach a garden hose from a fresh water faucet to the garden hose adapter.

5. Turn on the fresh water supply, and verify that there is good water pressure at the outboard motor.

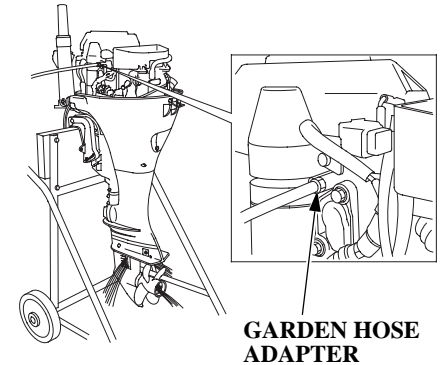

6. Flush the engine with fresh water for at least 10 minutes.
Do not run the engine.
7. After flushing, remove the garden hose adapter, reinstall the engine cover.
8. Tilt up the outboard motor and move the tilt lock lever to the LOCK position.

CLEANING AND FLUSHING

Flushing Without the Honda Garden Hose Adapter

It is necessary to run the engine during the flushing procedure. For safety, remove the propeller from the outboard motor (p. 91).

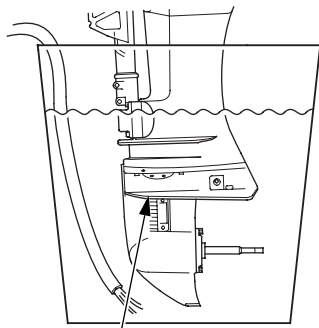

ANTIVENTILATION PLATE

1. Tilt down the outboard motor.
2. Place a container under the outboard motor, and fill it with clean, fresh water. The water level must be at least 2 inches (5 cm) above the antiventilation plate.

NOTICE

Running the engine without good water circulation can cause overheating and water pump damage.

Damage caused by running the outboard motor without sufficient cooling water is not covered by the *Distributor's Limited Warranty* (p. 128).

3. Start the engine and run in the N (neutral) position at low speed for at least 10 minutes.
4. After flushing, stop the engine, and disconnect the fuel hose from the outboard motor. Remove the water container, and reinstall the propeller (p. 92).
5. Tilt up the outboard motor and move the tilt lock lever to the LOCK position.

Fuel

NOTICE

Depending on the region where you operate your outboard, fuel formulations may deteriorate and oxidize rapidly. Fuel deterioration and oxidation can occur in as little as 15 days and may cause damage to the carburetors and fuel system. Please check with your servicing dealer for local storage recommendations.

Gasoline will oxidize and deteriorate in storage. Deteriorated gasoline will cause hard starting, and it leaves gum deposits that clog the fuel system. If the gasoline in your fuel tank and carburetor deteriorates during storage, you may need to have the carburetor and other fuel system components serviced or replaced.

The length of time that gasoline can be left in your fuel tank and carburetor without causing functional problems will vary with such factors as gasoline blend, your storage temperatures, and whether the fuel tank is partially or completely filled. The air in a partially filled fuel tank promotes fuel deterioration. Very warm storage temperatures accelerate fuel deterioration. Fuel deterioration problems may occur in less than 15 days, if the gasoline was not fresh when you filled the fuel tank.

The *Distributor's Limited Warranty* (p. 128) does not cover fuel system damage or engine performance problems resulting from neglected storage preparation.

You can extend fuel storage life by adding a gasoline stabilizer that is formulated for that purpose, or you can avoid fuel deterioration problems by draining all the fuel from the fuel tank and carburetor.

Adding a Fuel Stabilizer

When adding a fuel stabilizer, fill the fuel tank with fresh gasoline. If only partially filled, air in the tank will promote fuel deterioration during storage. If you keep an additional container of gasoline for refueling, be sure that it contains only fresh gasoline.

1. Add Honda Marine fuel stabilizer following the instructions on the label.
2. After adding a fuel stabilizer, run the engine in water for 10 minutes to be sure that the treated gasoline has replaced the untreated gasoline in the carburetor.
3. Turn the engine OFF.

STORAGE

Draining the Fuel System

You can avoid fuel deterioration problems by draining the fuel tank and carburetor.

1. Disconnect the fuel hose from the outboard motor.

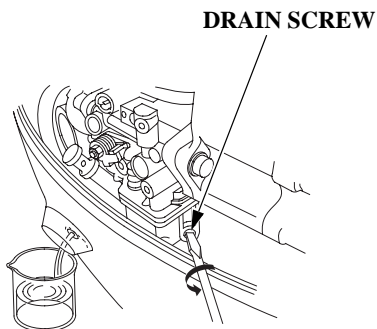

2. With the outboard motor in a vertical position, place an approved gasoline container below the fuel drain outlet, and use a funnel to avoid spilling fuel. Loosen the drain screw to drain fuel from the carburetor.

⚠ WARNING

Gasoline is highly flammable and explosive.

You can be burned or seriously injured when handling fuel.

- Stop the engine and keep heat, sparks, and flame away.
- Handle fuel only outdoors.
- Wipe up spills immediately.

3. After the fuel has drained from the carburetor, tighten the drain screw securely.

4. Drain the fuel tank into an approved gasoline container, or if you need to store fuel in the fuel tank, you can extend fuel storage life by filling the fuel tank with fresh gasoline and adding Honda Marine fuel stabilizer following the directions on the container. Close the fuel cap vent.

If using the portable fuel tank, close the fuel filler cap vent knob. Store the portable fuel tank in a cool dry place out of direct sunlight.

Engine Oil

1. Change the engine oil and the oil filter (p. 76 – 78).
2. Remove the spark plugs (p. 83), and remove the emergency stop switch clip from the emergency stop switch.
3. Pour 1 – 2 teaspoons (5 – 10 cm³) of clean engine oil into each cylinder.
4. Pull the starter grip several times to distribute the oil in the cylinder.
5. Reinstall the spark plugs (p. 84).

STORAGE PRECAUTIONS

Select a well-ventilated storage area. If possible, avoid storage areas with high humidity.

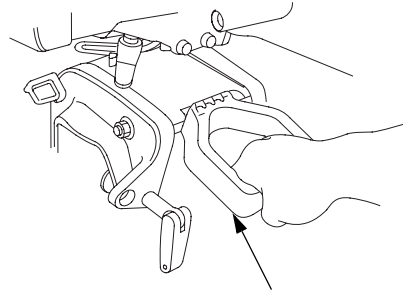

CARRYING HANDLE

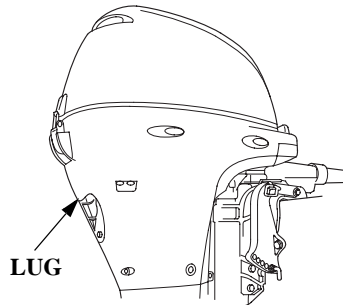

LUG

To carry the outboard motor, hold it by the carrying handle, or hold by the carrying handle and the lug beneath the engine cover latch, as shown.

NOTICE

Lifting the outboard motor by the engine cover, or using the installed outboard motor as a handle or lever to move the boat, can damage the outboard motor.

If your portable fuel tank contains gasoline, store it away from any appliance that operates with a flame, such as a furnace, water heater, or clothes dryer. Also avoid any area with a spark-producing electric motor, or where power tools are operated.

STORAGE

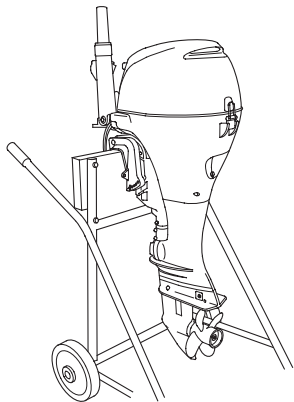

Store the outboard motor either vertically or horizontally with the tiller handle side up.

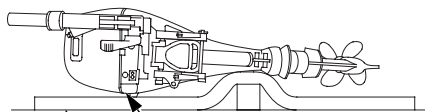

PROTECTOR CASE PROTECTOR

If it is necessary to store the outboard horizontally, drain the carburetor (p. 96) and drain the engine oil (p. 76), before removing the outboard motor from the boat.

Fold the tiller handle, and rest the outboard motor on its case protectors. Be sure all water has drained from the outboard motor before placing it on its side, so no residual water can enter the engine exhaust port.

NOTICE

Any other horizontal storage position may cause damage to the outboard motor or oil leakage.

Cover the outboard motor to keep out dust. Do not use plastic sheet as a dust cover. A nonporous cover will trap moisture, promoting rust and corrosion.

REMOVAL FROM STORAGE

Check your outboard motor as described in the *BEFORE OPERATION* chapter of this manual.

If the cylinders were coated with oil during storage preparation, the engine may smoke briefly at startup. This is normal.

TRANSPORTING

WITH OUTBOARD MOTOR INSTALLED ON BOAT

When trailering a boat with the outboard motor attached, always disconnect the fuel line from the portable fuel tank and tighten the friction lever securely (p. 61).

The preferred method is to leave the engine in the normal running position, but if there is insufficient road clearance, you can tilt the outboard motor using a commercially available outboard motor support bar available through your dealer. Refer to the manufacturer's instructions for using an outboard motor support bar.



OUTBOARD MOTOR SUPPORT BAR
(commercially available)

WITH OUTBOARD MOTOR REMOVED FROM BOAT

Secure the outboard motor in either the vertical or horizontal position shown on p. 98.

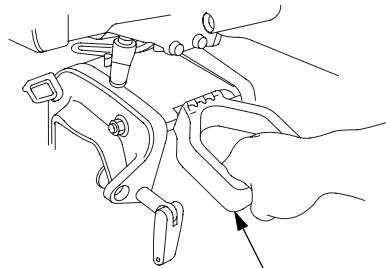

CARRYING HANDLE

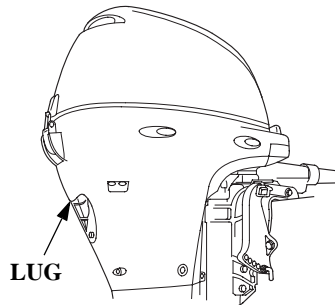

LUG

To carry, hold the outboard motor by the carrying handle, or hold by the carrying handle and the lug beneath the engine cover lock latch, as shown.

NOTICE

Lifting the outboard motor by the engine cover, or using the installed outboard motor as a handle or lever to move the boat, can damage the outboard motor.

TAKING CARE OF UNEXPECTED PROBLEMS

ELECTRIC STARTER WILL NOT OPERATE

Possible Cause	Correction
Battery connections loose or corroded.	Clean and tighten battery connections.
Battery discharged.	Recharge battery.
Fuse burnt out.	Replace fuse (p. 105).
Starter malfunction, switch malfunction, or electrical problem in the starting circuit.	Use emergency starting procedure (p. 54), then take outboard motor to an authorized Honda Marine dealer, or refer to the shop manual.

TAKING CARE OF UNEXPECTED PROBLEMS

ENGINE WILL NOT START

Possible Cause	Correction
Clip not inserted in emergency stop switch.	Insert clip in emergency stop switch.
Gearshift lever or control lever not in neutral position.	Shift to neutral (p. 50 or 52).
Choke OFF (tiller handle and manual choke type).	Pull choke knob to ON position, unless engine is warm (p. 50).
Throttle grip not in START position (tiller handle type).	Turn throttle grip to START position (p. 50).
Fast idle lever raised (remote control/side-mount type).	Leave fast idle lever OFF, if the engine is warm (p. 53).

TAKING CARE OF UNEXPECTED PROBLEMS

ENGINE WILL NOT START

Possible Cause	Correction
Out of fuel.	Refuel (p. 84).
Fuel vent closed (portable fuel tank).	Open fuel filler cap vent (p. 85).
Fuel hose not primed.	Squeeze priming bulb (p. 48).
Fuel filter or fuel tank filter restricted.	Replace restricted filters (p. 87 or 90).
Bad fuel; outboard motor stored without treating or draining gasoline, or refueled with bad gasoline.	Drain fuel tank and carburetors (p. 96). Refill with fresh gasoline (p. 84).
Spark plugs faulty, fouled, or improperly gapped.	Gap or replace spark plugs (p. 83).
Spark plugs wet with fuel (flooded engine).	Dry and reinstall spark plugs. Start engine with choke and throttle open.
Carburetor malfunction, fuel pump failure, ignition malfunction, stuck valves, etc.	Take outboard motor to an authorized Honda Marine dealer, or refer to the shop manual.

TAKING CARE OF UNEXPECTED PROBLEMS

HARD STARTING OR STALLS AFTER STARTING

Possible Cause	Correction
Choke OFF (tiller handle and manual choke type).	Pull choke knob to ON position, unless engine is warm (p. 50).
Throttle grip not in START position (tiller handle type).	Turn throttle grip to START position (p. 50).
Fast idle lever raised (remote control/side-mount type).	Leave fast idle lever OFF, unless engine is warm (p. 53).
Fuel vent closed (portable fuel tank).	Open fuel filler cap vent (p. 85).
Fuel hose not primed.	Squeeze priming bulb (p. 49).
Fuel filter or fuel tank filter restricted.	Replace restricted filters (p. 87 or 90).
Bad fuel; outboard motor stored without treating or draining gasoline, or refueled with bad fuel.	Drain fuel tank and carburetors (p. 96). Refill with fresh gasoline (p. 84).

TAKING CARE OF UNEXPECTED PROBLEMS

HARD STARTING OR STALLS AFTER STARTING

Possible Cause	Correction
Spark plugs faulty, fouled, or improperly gapped.	Gap or replace spark plugs (p. 83).
Carburetor malfunction, fuel pump failure, ignition malfunction, etc.	Take outboard motor to an authorized Honda Marine dealer, or refer to the shop manual.

ENGINE OVERHEATS

Possible Cause	Correction
Water intake screens clogged.	Clean water intake screens.
Faulty thermostat or water pump.	Take outboard motor to an authorized Honda Marine dealer, or refer to the shop manual.

TAKING CARE OF UNEXPECTED PROBLEMS

BATTERY WILL NOT CHARGE AND ELECTRIC STARTER WILL NOT OPERATE

The battery-charging circuit and the electric starter relay circuit are protected by the 20-ampere fuse. If the fuse burns out, the engine will not charge the battery, and the electric starter will not operate. The engine can be started using the recoil starter or the emergency starter rope.

The ignition switch is protected by the 20-ampere fuse. If the fuse burns out, the engine will not start or run, and the power tilt switch will not operate.

Fuse Replacement

1. With the engine stopped, remove the engine cover.
2. Remove the fuse case lid.

3. Remove and inspect the fuse. If burnt out, install a replacement fuse of the specified rating. The outboard motor only comes with one spare fuse in the fuse holder.

DESIGNATED FUSE RATING:
20A

NOTICE

Never use a fuse with a rating greater than specified. Serious damage to the electrical system could result.

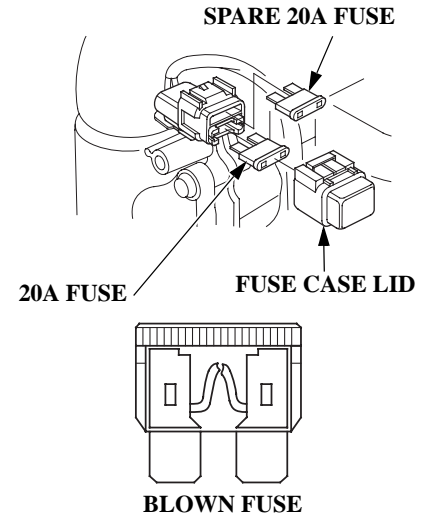

4. Reinstall the fuse case lid and the engine cover.

Before further operation, try to determine and correct the electrical problem that caused the fuse to burn out. An uncorrected electrical problem may cause the fuse to burn out again.

TAKING CARE OF UNEXPECTED PROBLEMS

OIL PRESSURE INDICATOR GOES OFF AND ENGINE SPEED IS LIMITED

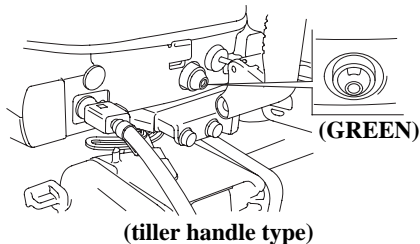

(tiller handle type)

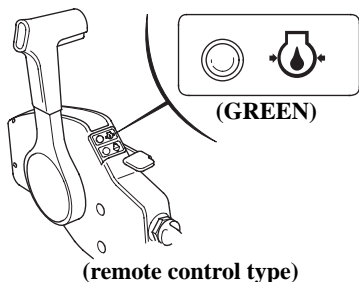

(remote control type)

If oil pressure becomes low, the green indicator will go off, and the engine protection system will limit engine speed. If you are at cruising speed, engine speed will decrease automatically.

When normal oil pressure is restored, the engine speed will gradually rise to normal engine speed.

Remote control types are equipped with a buzzer that sounds continuously when the green indicator goes off.

The buzzer sound stops below an engine speed of 1,400 rpm.

Low oil pressure may be the result of a low engine oil level, or there may be a problem with the engine lubrication system.

If the throttle is closed suddenly after full throttle operation, engine speed may drop below the specified idle rpm, and that could activate the engine protection system momentarily.

If low oil pressure activates the engine protection system, stop the engine, check the engine oil level (p. 75), and add oil if needed.

With the engine oil at the recommended level, restart the engine. If the lubrication system is OK, the green indicator should come on within 30 seconds, and the engine will respond normally to throttle grip or control lever operation.

If the engine protection system remains activated after 30 seconds, return to the nearest boat landing, and have the outboard motor inspected by an authorized Honda Marine dealer.

TAKING CARE OF UNEXPECTED PROBLEMS

OVERHEAT AND ENGINE SPEED IS LIMITED

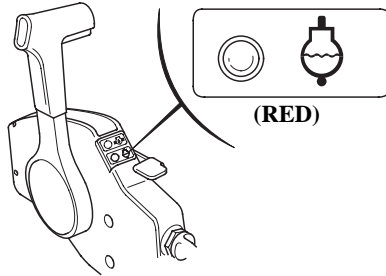

(R type)

If the engine overheats, the red indicator will come on and the buzzer will sound a continuous tone as the engine speed is reduced to 1,800 rpm. If the condition persists for another 20 seconds, the engine will shut off.

(H type)

If the engine overheats, the engine speed will be reduced to 1,800 rpm. If the condition persists for another 20 seconds, the engine will shut off.

(all types)

If you are at cruising speed when the overheat protection system is activated, the engine speed will decrease automatically. When normal engine temperature is restored, the engine speed will gradually rise to normal engine speed.

Engine overheating may be the result of restricted water intake screens, or there may be a problem with the cooling system thermostat or water pump.

If the engine is stopped after running at full throttle, and then restarted soon afterward, that could activate the engine protection system momentarily.

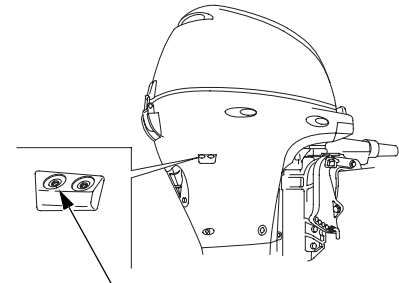

COOLING SYSTEM INDICATOR

If overheating activates the engine protection system, idle the engine in neutral, and check the cooling system indicator.

TAKING CARE OF UNEXPECTED PROBLEMS

If water is flowing from the cooling system indicator, continue idling for 30 seconds. If the cooling system is OK, the red indicator should go off within 30 seconds (R types), and the engine will respond normally to throttle grip or control lever operation.

If there is no water flowing from the cooling system indicator, stop the engine, and tilt the outboard motor to inspect the water intake screens. If clogged, clean the water intake screens, return the outboard motor to the running position, restart the engine, and check the cooling system indicator again.

If there is still no water flowing from the cooling system indicator, or if the engine protection system remains activated after 30 seconds, return to the nearest boat landing, and have the outboard motor inspected by an authorized Honda Marine dealer.

TAKING CARE OF UNEXPECTED PROBLEMS

SUBMERGED OUTBOARD MOTOR

A submerged outboard motor must be serviced immediately after it is recovered from the water in order to minimize corrosion.

If there is a Honda Marine dealership nearby, take the outboard motor to the dealer immediately. If you are far from a dealer, proceed as follows:

1. Remove the engine cover, and rinse the outboard motor with fresh water to remove salt water, sand, mud, etc.
2. Drain the carburetor as described on p. 96.

3. Change the engine oil and oil filter as described on p. 76 – 78 . If there was water in the engine crankcase, or if the used engine oil showed signs of water contamination, then a second engine oil change should be performed after running the engine for half an hour.

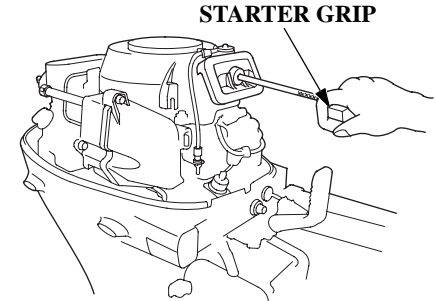

4. Remove the spark plugs (p. 83), and remove the clip from the emergency stop switch or engine stop switch. Pull the starter grip, rotate the flywheel a few revolutions to completely expel any water from the cylinders.

If the engine was running when it submerged, there may be mechanical damage, such as bent connecting rods. If the engine binds when cranked, do not attempt to run the engine until it has been repaired.

TAKING CARE OF UNEXPECTED PROBLEMS

NOTICE

When cranking the engine with an open ignition circuit (spark plugs removed from the ignition circuit), remove the clip from the emergency stop switch to prevent possible damage to the ignition system.

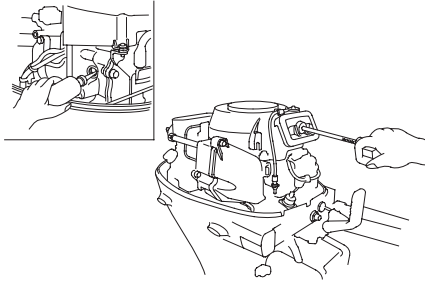

5. Pour a teaspoon of engine oil into the spark plug hole, and then pull the starter grip several times to lubricate the inside of the cylinder.
6. Reinstall the spark plugs, and put the emergency stop switch clip into the emergency stop switch.

7. Attempt to start the engine.

If the engine fails to start, remove the spark plugs, dry them, then reinstall the spark plugs and attempt to start the engine again.

If the engine starts, and no mechanical damage is evident, continue to run the engine for a half hour or longer. Be sure the water level is at least 2 inches (5 cm) above the antiventilation plate to avoid overheating and water pump damage.

8. As soon as possible, take the outboard motor to an authorized Honda Marine dealer for inspection and service.

TECHNICAL INFORMATION

Serial Number Locations

Record the product identification number, the engine serial number, and the date of purchase in the space provided on this page. You will need these numbers when ordering parts, and when making technical or warranty inquiries (p. 125).

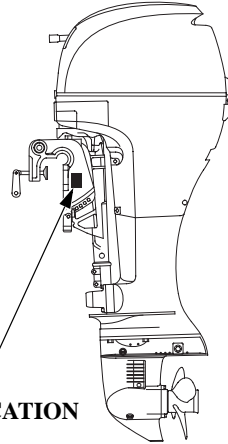

PRODUCT IDENTIFICATION NUMBER

The product identification number is stamped on a plate attached on the left side of the stern bracket.

Product identification number:

Date of purchase:

ENGINE SERIAL NUMBER

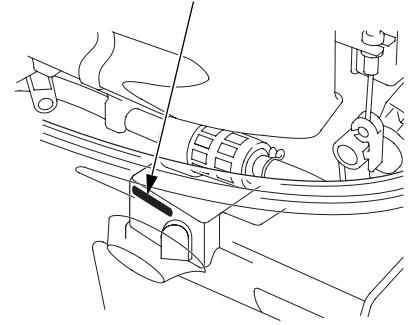

The engine serial number is stamped on the right front of the engine.

Engine serial number:

TECHNICAL INFORMATION

Carburetor Modification for High Altitude Operation

At altitudes above 3,000 feet (900 meters), the standard carburetor air-fuel mixture will be too rich. Performance will decrease, and fuel consumption will increase. A very rich mixture will also foul the spark plug and cause hard starting. Operation at an altitude that differs from that at which this engine was certified, for extended periods of time, may increase emissions.

High altitude operation can be improved by specific modifications to the carburetor. If you usually operate your outboard motor at 3,000 feet (900 meters) or above, consult with your authorized Honda Marine dealer. Your dealer can determine the appropriate carburetor settings for the altitude at which you operate your outboard motor.

Even with carburetor modification, engine horsepower will decrease about 3.5% for each 1,000-foot (300-meter) increase in altitude. The effect of altitude on horsepower will be greater than this if no carburetor modification is made.

NOTICE

When the carburetor has been modified for operation at one of the higher altitude ranges, the air-fuel mixture will be too lean for operation at a lower altitude. Operation at altitudes below the range for which the carburetor is set may cause the engine to overheat and result in serious engine damage. For use at lower altitudes, have an authorized Honda Marine dealer modify the carburetor for the correct altitude range.

Emission Control System Information

Source of Emissions

The combustion process produces carbon monoxide, oxides of nitrogen, and hydrocarbons. Control of hydrocarbons and oxides of nitrogen is very important because, under certain conditions, they react to form photochemical smog when subjected to sunlight. Carbon monoxide does not react in the same way, but it is toxic.

Honda utilizes appropriate air/fuel ratios and other emissions control systems to reduce the emissions of carbon monoxide, oxides of nitrogen, and hydrocarbons.

The U.S., California Clean Air Acts, and Environment Canada

EPA, California, and Canadian regulations require all manufacturers to furnish written instructions describing the operation and maintenance of emission control systems.

The following instructions and procedures must be followed in order to keep the emissions from your Honda engine within the emission standards.

Tampering and Altering

NOTICE

Tampering is a violation of Federal and California law.

Tampering with or altering the emission control system may increase emissions beyond the legal limit. Among those acts that constitute tampering are:

- Removal or alteration of any part of the intake, fuel, or exhaust systems.
- Alterations that would cause the engine to operate outside its design parameters.

TECHNICAL INFORMATION

Problems That May Affect Emissions

If you are aware of any of the following symptoms, have your engine inspected and repaired by your servicing dealer.

- Hard starting or stalling after starting.
- Rough idle.
- Misfiring or backfiring under load.
- Afterburning (backfiring).
- Black exhaust smoke or high fuel consumption.

Replacement Parts

The emission control systems on your Honda engine were designed, built, and certified to conform with EPA and California emission regulations. We recommend the use of Honda Genuine parts whenever you have maintenance done. These original-design replacement parts are manufactured to the same standards as the original parts, so you can be confident of their performance. The use of replacement parts that are not of the original design and quality may impair the effectiveness of your emission control system.

A manufacturer of an aftermarket part assumes the responsibility that the part will not adversely affect emission performance. The manufacturer or rebuilder of the part must certify that use of the part will not result in a failure of the engine to comply with emission regulations.

Maintenance

Follow the maintenance schedule on (p.72 and 73). Remember that this schedule is based on the assumption that your machine will be used for its designed purpose. Sustained high-load operation, or use in unusual conditions, will require more frequent service.

Star Label US, Puerto Rico, and US Virgin Islands

A Star label was applied to this outboard motor in accordance with the requirements of the California Air Resources Board.

The Star Label means Cleaner Marine Engine

This engine has been certified as a:

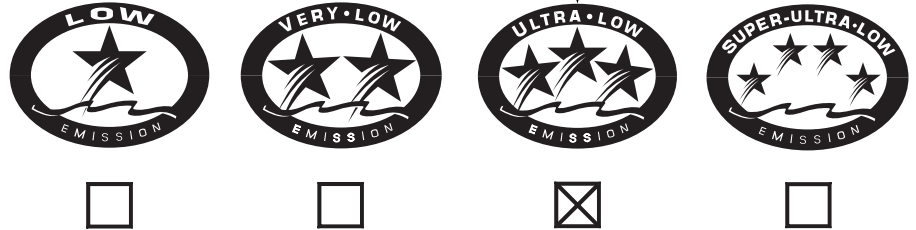

The Symbol for Cleaner Marine Engines:

Cleaner Air and Water - for healthier lifestyle and environment.

Better Fuel Economy - burns up to 30 - 40 percent less gas and oil than conventional carbureted two-stroke engines, saving money and resources.

Longer Emission Warranty - protects consumer for worry-free operation.

TECHNICAL INFORMATION



One Star Low Emission

The one-star label identifies engines that meet the Air Resources Board's Personal Watercraft and Outboard marine engine 2001 exhaust emission standards. Engines meeting these standards have 75% lower emissions than conventional carbureted two-stroke engines. These engines are equivalent to the U.S. EPA's 2006 standards for marine engines.



Two Stars Very Low Emission

The two-star label identifies engines that meet the Air Resources Board's Personal Watercraft and Outboard marine engine 2004 exhaust emission standards. Engines meeting these standards have 20% lower emissions than One Star-Low Emission engines.



Three Stars Ultra Low Emission

The three-star label identifies engines that meet the Air Resources Board's Personal Watercraft and Outboard marine engine 2008 exhaust emission standards or the Sterndrive and Inboard marine engine 2003-2008 exhaust emission standards. Engines meeting these standards have 65% lower emissions than One Star-Low Emission engines.



Four Stars Super Ultra Low Emission

The four-star label identifies engines that meet the Air Resources Board's Sterndrive and Inboard marine engine 2009 exhaust emission standards. Personal Watercraft and Outboard marine engines may also comply with these standards. Engines meeting these standards have 90% lower emissions than One Star-Low Emission engines.

Cleaner Watercraft - Get the Facts
1-800-END-SMOG
www.arb.ca.gov

TECHNICAL INFORMATION

Specifications

MODEL		BF8D/BFP8D			
Description code		BAAJ			
Type		H	HS	HT	RT
Overall length		24.0 in (610 mm)			23.6 in (600 mm)
Overall width		13.6 in (345 mm)			
Overall height	S	43.5 in (1,105 mm)			
	L	48.6 in (1,235 mm)			
	X	54.1 in (1,375 mm)			
Transom height (when transom angle at 12°)	S	17.0 in (433 mm)			
	L	22.2 in (563 mm)			
	X	27.7 in (703 mm)			
Dry mass [weight]	S	92.6 lbs (42.0 kg)	–	–	–
	L	98.1 lbs (44.5 kg)	105.8 lbs (48.0 kg)	123.5 lbs (56.0 kg)	121.3 lbs (55.0 kg)
	X	–	114.6 lbs (52.0 kg)	–	–
Rated power		6.0 kW (8 HP)			
Full throttle range		4,500 – 5,500 rpm			
Engine type		4 stroke OHC in-line 2 cylinder, water-cooled			
Displacement		13.5 cu-in (222 cm ³)			
Starter system		Recoil starter	Recoil starter, Electric starter		
Ignition system		Digital ICM (Ignition Control Module)			
Lubrication system		Trochoid pump pressure lubrication			
Specified oil		Engine: API Service classification (SG, SH, SJ) SAE/FC-W 10W-30 Gear case: API Service classification (GL-4) SAE 90 Hypoid gear oil			

Honda outboard motors are power rated in accordance with NMMA procedures and using the ICOMIA standard 28/23.

TECHNICAL INFORMATION

Oil capacity	Engine: 1.1 US qt (1.0 L) without oil filter change 1.2 US qt (1.1 L) with oil filter change Gear case: 0.31 US qt (0.29 L)		
CARB star label	ULTRA · LOW EMISSION		
D.C. output	12V – 6A	12V – 12A	12V – 12A
Cooling system	Water cooling with thermostat		
Exhaust system	Under water exhaust/thru hub		
Spark plugs	CR5EH-9 (NGK), U16FER9 (DENSO)		
Fuel pump	Diaphragm type fuel pump		
Fuel	Unleaded gasoline (86 pump octane, or higher)		
Tank capacity	3.2 US gal (12 L)		
Gear change	Forward-Neutral-Reverse (dog type)		
Steering angle	45° right and left		
Transom angle	(Manual tilt type): 5 stages (4°, 8°, 12°, 16°, 20°) (T type): 4 stages (8°, 12°, 16°, 20°)		
Tilt angle	(Manual tilt S and L handle type): 3 stages adjustment (22°, 37° and 63°/transom angle at 12°) (Manual tilt X handle type, and R type): 3 stages adjustment (22°, 37° and 64°/transom angle at 12°) (T type): Stageless (64°/transom angle at 12°)		
Remote control steering system	–		Outboard motor-mounted

Tuneup

Spark plug gap	0.031 – 0.035 in (0.8 – 0.9 mm)	Refer to page 83.
Idle speed	900 ± 50 rpm	See shop manual
Valve clearance (cold)	IN: 0.17 ± 0.02 mm EX: 0.23 ± 0.02 mm	See shop manual
Other specifications	No other adjustments needed.	

Honda outboard motors are power rated in accordance with NMMA procedures and using the ICOMIA standard 28/23.

TECHNICAL INFORMATION

Specifications

MODEL	BF9.9D/BFP9.9D					
Description code	BABJ					
Type	H	HS	HT	R	RT	
Overall length	24.0 in (610 mm)			23.6 in (600 mm)		
Overall width	13.6 in (345 mm)					
Overall height	S	43.5 in (1,105 mm)				
	L	48.6 in (1,235 mm)				
	X	54.1 in (1,375 mm)				
Transom height (when transom angle at 12°)	S	17.0 in (433 mm)				
	L	22.2 in (563 mm)				
	X	27.7 in (703 mm)				
Dry mass [weight]	S	92.6 lbs (42.0 kg)	100.3 lbs (45.5 kg)	–	–	–
	L	98.1 lbs (44.5 kg)	105.8 lbs (48.0 kg)	123.5 lbs (56.0 kg)	106.9 lbs (48.5 kg)	121.3 lbs (55.0 kg)
	X	106.9 lbs (48.5 kg)	114.6 lbs (52.0 kg)	129.0 lbs (58.5 kg)	–	126.8 lbs (57.5 kg)
Rated power	7.4 kW (9.9 HP)					
Full throttle range	5,000 – 6,000 rpm					
Engine type	4 stroke OHC in-line 2 cylinder, water-cooled					
Displacement	13.5 cu-in (222 cm ³)					
Starter system	Recoil starter	Recoil starter, Electric starter				
Ignition system	Digital ICM (Ignition Control Module)					
Lubrication system	Trochoid pump pressure lubrication					
Specified oil	Engine: API Service classification (SG, SH, SJ) SAE/FC-W 10W-30 Gear case: API Service classification (GL-4) SAE 90 Hypoid gear oil					

Honda outboard motors are power rated in accordance with NMMA procedures and using the ICOMIA standard 28/23.

TECHNICAL INFORMATION

Oil capacity	Engine: 1.1 US qt (1.0 L) without oil filter change 1.2 US qt (1.1 L) with oil filter change Gear case: 0.31 US qt (0.29 L)		
CARB star label	ULTRA · LOW EMISSION		
D.C. output	12V – 6A	12V – 12A	12V – 12A
Cooling system	Water cooling with thermostat		
Exhaust system	Under water exhaust/thru hub		
Spark plugs	CR5EH-9 (NGK), U16FER9 (DENSO)		
Fuel pump	Diaphragm type fuel pump		
Fuel	Unleaded gasoline (86 pump octane, or higher)		
Tank capacity	3.2 US gal (12 L)		
Gear change	Forward-Neutral-Reverse (dog type)		
Steering angle	45° right and left		
Transom angle	(Manual tilt type): 5 stages (4°, 8°, 12°, 16°, 20°) (T type): 4 stages (8°, 12°, 16°, 20°)		
Tilt angle	(Manual tilt S and L handle type): 3 stages adjustment (22°, 37° and 63°/transom angle at 12°) (Manual tilt X handle type, and R type): 3 stages adjustment (22°, 37° and 64°/transom angle at 12°) (T type): Stageless (64°/transom angle at 12°)		
Remote control steering system	–		Outboard motor-mounted

Tuneup

Spark plug gap	0.031 – 0.035 in (0.8 – 0.9 mm)	Refer to page 83.
Idle speed	900 ± 50 rpm	See shop manual
Valve clearance (cold)	IN: 0.17 ± 0.02 mm EX: 0.23 ± 0.02 mm	See shop manual
Other specifications	No other adjustments needed.	

Honda outboard motors are power rated in accordance with NMMA procedures and using the ICOMIA standard 28/23.

TECHNICAL INFORMATION

Specifications

MODEL	BF15D/BFP15D					
Description code	BALJ					
Type	H	HG	HS	HT	RT	
Overall length	25.6 in (650 mm)				25.2 in (640 mm)	
Overall width	13.8 in (350 mm)					
Overall height	S	43.7 in (1,110 mm)				
	L	48.8 in (1,240 mm)				
	X	54.3 in (1,380 mm)				
Transom height (when transom angle at 12°)	S	17.0 in (433 mm)				
	L	22.2 in (563 mm)				
	X	27.7 in (703 mm)				
Dry mass [weight]	S	102.5 lbs (46.5 kg)	–	108.0 lbs (49.0 kg)	126.8 lbs (57.5 kg)	–
	L	109.1 lbs (49.5 kg)	126.8 lbs (57.5 kg)	114.6 lbs (52.0 kg)	131.2 lbs (59.5 kg)	129.0 lbs (58.5 kg)
	X	–	–	–	136.7 lbs (62.0 kg)	134.5 lbs (61.0 kg)
Rated power	11.2 kW (15 HP)					
Full throttle range	4,500 – 5,500 rpm					
Engine type	4 stroke OHC in-line 2 cylinder, water-cooled					
Displacement	21.4 cu-in (350 cm ³)					
Starter system	Recoil starter	Recoil starter, Electric starter				
Ignition system	Digital ICM (Ignition Control Module)					
Lubrication system	Trochoid pump pressure lubrication					
Specified oil	Engine: API Service classification (SG, SH, SJ) SAE/FC-W 10W-30 Gear case: API Service classification (GL-4) SAE 90 Hypoid gear oil					

Honda outboard motors are power rated in accordance with NMMA procedures and using the ICOMIA standard 28/23.

TECHNICAL INFORMATION

Oil capacity	Engine: 1.1 US qt (1.0 L) without oil filter change 1.2 US qt (1.1 L) with oil filter change Gear case: 0.31 US qt (0.29 L)	
CARB star label	ULTRA · LOW EMISSION	
D.C. output	12V – 6A	12V – 12A
Cooling system	Water cooling with thermostat	
Exhaust system	Under water exhaust/thru hub	
Spark plugs	CR5EH-9 (NGK), U16FER9 (DENSO)	
Fuel pump	Diaphragm type fuel pump	
Fuel	Unleaded gasoline (86 pump octane, or higher)	
Tank capacity	3.2 US gal (12 L)	
Gear change	Forward-Neutral-Reverse (dog type)	
Steering angle	45° right and left	
Transom angle	(Manual tilt type): 5 stages (4°, 8°, 12°, 16°, 20°) (G and T types): 4 stages (8°, 12°, 16°, 20°)	
Tilt angle	(Manual tilt S handle type): 3 stages adjustment (22°, 37° and 63°/transom angle at 12°) (Manual tilt L and X handle types, and R types): 3 stages adjustment (22°, 37° and 64°/transom angle at 12°) (G and T types): Stageless (64°/transom angle at 12°)	
Remote control steering system	–	Outboard motor-mounted

Tuneup

Spark plug gap	0.031 – 0.035 in (0.8 – 0.9 mm)	Refer to page 83.
Idle speed	900 ± 50 rpm	See shop manual
Valve clearance (cold)	IN: 0.17 ± 0.02 mm EX: 0.23 ± 0.02 mm	See shop manual
Other specifications	No other adjustments needed.	

Honda outboard motors are power rated in accordance with NMMA procedures and using the ICOMIA standard 28/23.

TECHNICAL INFORMATION

Specifications

MODEL	BF20D						
Description code	BAMJ						
Type	H	HG	HS	HT	R	RT	
Overall length	25.6 in (650 mm)				25.2 in (640 mm)		
Overall width	13.8 in (350 mm)						
Overall height	S	43.7 in (1,110 mm)					
	L	48.8 in (1,240 mm)					
Transom height (when transom angle at 12°)	S	17.0 in (433 mm)					
	L	22.2 in (563 mm)					
Dry mass [weight]	S	102.5 lbs (46.5 kg)	-	108.0 lbs (49.0 kg)	126.8 lbs (57.5 kg)	109.1 lbs (49.5 kg)	125.7 lbs (57.0 kg)
	L	109.1 lbs (49.5 kg)	126.8 lbs (57.5 kg)	-	131.2 lbs (59.5 kg)	-	129.0 lbs (58.5 kg)
Rated power	14.9 kW (20 HP)						
Full throttle range	5,000 – 6,000 rpm						
Engine type	4 stroke OHC in-line 2 cylinder, water-cooled						
Displacement	21.4 cu-in (350 cm ³)						
Starter system	Recoil starter	Recoil starter, Electric starter					
Ignition system	Digital ICM (Ignition Control Module)						
Lubrication system	Trochoid pump pressure lubrication						
Specified oil	Engine: API Service classification (SG, SH, SJ) SAE/FC-W 10W-30 Gear case: API Service classification (GL-4) SAE 90 Hypoid gear oil						

Honda outboard motors are power rated in accordance with NMMA procedures and using the ICOMIA standard 28/23.

TECHNICAL INFORMATION

Oil capacity	Engine: 1.1 US qt (1.0 L) without oil filter change 1.2 US qt (1.1 L) with oil filter change Gear case: 0.31 US qt (0.29 L)	
CARB star label	ULTRA · LOW EMISSION	
D.C. output	12V – 6A	12V – 12A
Cooling system	Water cooling with thermostat	
Exhaust system	Under water exhaust/thru hub	
Spark plugs	CR5EH-9 (NGK), U16FER9 (DENSO)	
Fuel pump	Diaphragm type fuel pump	
Fuel	Unleaded gasoline (86 pump octane, or higher)	
Tank capacity	3.2 US gal (12 L)	
Gear change	Forward-Neutral-Reverse (dog type)	
Steering angle	45° right and left	
Transom angle	(Manual tilt type): 5 stages (4°, 8°, 12°, 16°, 20°)	
	(G and T types): 4 stages (8°, 12°, 16°, 20°)	
Tilt angle	(Manual tilt S handle type): 3 stages adjustment (22°, 37° and 63°/transom angle at 12°)	
	(Manual tilt L handle type, and R types): 3 stages adjustment (22°, 37° and 64°/transom angle at 12°) (G and T types): Stageless (64°/transom angle at 12°)	
Remote control steering system	–	Outboard motor-mounted

Tuneup

Spark plug gap	0.031 – 0.035 in (0.8 – 0.9 mm)	Refer to page 83.
Idle speed	900 ± 50 rpm	See shop manual
Valve clearance (cold)	IN: 0.17 ± 0.02 mm EX: 0.23 ± 0.02 mm	See shop manual
Other specifications	No other adjustments needed.	

Honda outboard motors are power rated in accordance with NMMA procedures and using the ICOMIA standard 28/23.

CONSUMER INFORMATION

Honda Publications (United States, Puerto Rico, and U.S. Virgin Islands)

These publications will give you additional information for maintaining and repairing your outboard motor.

Shop Manual

This manual covers complete maintenance and overhaul procedures. It is intended to be used by a skilled technician.

Available through your Honda Marine dealer or visit <http://marine.honda.com/owners/manuals/shop-manuals>.

Parts Catalog

This manual provides complete, illustrated parts lists. The catalog is available through your Honda Marine dealer.

Accessory Catalog

Your authorized Honda Marine dealer offers a wide selection of accessories (optional equipment, oils, and lubricants) to enhance your boating experience.

Visit <http://marine.honda.com> and click on PARTS & ACCESSORIES to see the entire catalog of accessories.

Customer Service Information

Contacting Honda

Your Owner's Manual was written to cover most of the questions you might ask about your Honda. Any questions not answered in the Owner's Manual can be answered by your Honda dealer. If your dealer doesn't have an immediate answer, they should be able to get it for you.

If you have a difference of opinion with your dealer, please remember that each dealership is independently owned and operated. That's why it's

important to work to resolve any differences at the dealership level. If the service personnel are unable to assist you, please discuss your concerns with the dealer management such as the Service Manager or the dealership's owner.

If you need to contact Honda regarding your experiences with your Honda product or with your dealer, please contact the Honda office in your region:

American Honda Motor Co., Inc.

Marine Division

Customer Relations Office

4900 Marconi Drive

Alpharetta, GA 30005-8847

Telephone (770) 497 – 6400

M-F 8:30 am-7:00 pm (Eastern Time Zone)

Honda Canada Inc.

Customer Relations Office

180 Honda Boulevard

Markham, Ontario L6C 0H9

Tel: 1-888-946-6329 (Toll free)

Fax: 1-877-939-0909 (Toll free)

CONSUMER INFORMATION

Please include the following information in your communication:

- Your name, address and telephone number (complete with area code)
- Model and complete serial number
- Date of purchase
- Name and location of selling dealer
- Name and location of servicing dealer (if different)
- A detailed description of your concerns

Warranty Coverage

Your new Honda is covered by the following warranties:

- Distributor's Limited Warranty
- Emission Control System Warranty

Please read the warranty statements contained in this manual. There are responsibilities, restrictions, and exclusions that apply to these warranties.

To obtain warranty service you must take your Honda outboard motor, together with proof of original retail purchase date, at your expense, to a Honda engine dealer or distributor authorized to sell that product in the United States, Puerto Rico, the U.S. Virgin Islands or Canada.

It is important to realize that your warranty applies to defects in material or workmanship of your Honda. Your warranty coverage does not apply to normal wear or deterioration associated with using your Honda outboard motor.

Your warranty coverage will not be voided if you choose to perform your own maintenance. However, you should have the proper tools and service information and be mechanically qualified. Failures that occur due to modifications, improper maintenance, or service are not covered.

Warranty Service

Please remember that recommended maintenance interval servicing is not included in your warranty coverage. Additionally, your warranty does not apply to the normal wear of items (such as spark plug(s), water pump, etc.).

As the owner of a Honda product, your servicing dealer may ask you to authorize an inspection. If the problem is covered under warranty, your dealer will perform any warranty repairs for you at no cost. However, you may be responsible for additional non-warranty charges.

If you have questions about warranty coverage or the nature of the repair, it is best to talk to the service manager of your Honda dealer.

Sometimes, in spite of the best intentions of all concerned, a misunderstanding may occur. If you aren't satisfied with your dealer's

handling of the situation, we suggest you discuss your problem with the appropriate member of the dealership's management team. If the problem has already been reviewed with the appropriate manager of the Service, Parts, or Sales department, contact the owner of the dealership or their designated representative.

CONSUMER INFORMATION

Warranty Statements

The American Honda Distributor's Limited Warranty applies to outboards purchased in the United States, Puerto Rico, or the U.S. Virgin Islands. The Honda Canada Distributor's Warranty applies to outboards purchased in Canada. The product warranty is only valid in the country where the product was purchased.

United states, Puerto Rico and Virgin Islands

Distributor's Limited Warranty

This warranty is limited to Honda Outboard Motors and related original equipment distributed by American Honda Motor Co., Inc., Power Equipment Division, 4900 Marconi Drive, Alpharetta, Georgia 30005-8847.

Products Covered by Warranty:	Length of Warranty: (from date of original retail purchase)		
	NONCOMMERCIAL/ NONRENTAL	COMMERCIAL/RENTAL	STATE/LOCAL/FEDERAL GOVERNMENT
All models purchased before July 1, 2008 ⁽¹⁾⁽²⁾	36 months	12 months	24 months
All Models purchased on or after July 1, 2008 ⁽²⁾	60 months	12 months	24 months
Related original equipment items: BF2 through BF30 models: Portable fuel tank and original propeller. All models: Primer bulb/fuel line assembly and tiller handle.	The same duration as the outboard with which they were purchased.		

(1) Models purchased prior to July 1, 2008 (unless previously purchased with True-5 warranty from a participating dealer).

(2) 35, 65, & 105 Jet models: Jet pump assembly is a dealer installed option. Jet pump warranty is provided by Specialty Manufacturing Co. (Outboard Jets).

To Qualify for This Warranty:

The Honda Outboard Motor must be purchased from American Honda or a dealer authorized by American Honda to sell Honda Outboard Motors in the United States, Puerto Rico, or the U.S. Virgin Islands. This limited warranty applies to the first retail purchaser and each subsequent owner during the applicable warranty time period.

What American Honda Will Repair or Replace Under Warranty:

American Honda will repair or replace, at its option, any part that is proven to be defective in material or workmanship under normal use during the applicable warranty time period. Warranty repairs and replacements will be made without charge for parts or labor. Anything replaced under warranty becomes the property of American Honda Motor Company, Inc.

All parts replaced under warranty will be considered as part of the original product and any warranty on those parts will expire coincidentally with the original product warranty.

To Obtain Warranty Service:

You must, at your expense, take your Honda Outboard Motor and proof of the original purchase date to any dealer who is authorized to service Honda Outboard Motors in the United States, Puerto Rico, or the U.S. Virgin Islands, during the dealer's normal business hours. If you are unable to obtain warranty service, or are dissatisfied with the warranty service you receive, take the following steps: First, contact the owner of the dealership involved; normally this should resolve the problem. However, if you should require further assistance, write or call the Honda Marine Customer Relations. Please see *Contacting Honda* page 125.

CONSUMER INFORMATION

Exclusions:

This warranty does not extend to the following:

- Conditions caused by lack of routine maintenance or improper storage (as outlined in the Owner's Manual)
- Conditions caused by the use of propeller (s) that do not allow the outboard motor to run in its recommended full throttle rpm range
- Operation inconsistent with the recommended operation/duty cycle (as outlined in the Owner's Manual)
- Parts affected or damaged by an abuse, submersion and/or collision
- Normal wear and tear
- Fuel contamination and water entering engine through the fuel intake, air intake or exhaust system
- Operation with fuels, oils, additives and lubricants which are not suitable for use in the product
- Use in an application for which the outboard motor was not designed, such as racing or competitive use or any other misuse or neglect
- Incorporation of unsuitable attachments or parts
- The unauthorized alteration, improper installation and/or rigging, or any causes other than defects in material or workmanship
- Corrosion to steering system or electrical components, corrosion due to electrolysis, water born foreign chemicals, improper service or corrosion caused by damage or abuse

- Reimbursement for towing charges, in and out of water charges, or technician travel time
- Growth of marine organisms on outboard motor surfaces, external or internal
- Any product that has ever been declared a total loss or sold for salvage by a financial institution or insurer, or that has been issued a "salvage" or similar title under any state's law.

Disclaimer of consequential damage and limitation of implied warranties:

American Honda disclaims any responsibility for loss of time or use of the outboard, revenue, or the equipment in which the outboard is installed, transportation, commercial loss, or any other incidental or consequential damage. Any implied warranties are limited to the duration of this written limited warranty.

Some states do not allow limitations on how long an implied warranty lasts and/or do not allow the exclusion or limitation of incidental or consequential damages, so the above exclusions and limitations may not apply to you. This warranty gives you specific legal rights, and you may also have other rights which vary from state to state.

CONSUMER INFORMATION

Accessories and Replacement Parts

This warranty is limited to Honda Marine parts, accessories and apparel when distributed by American Honda Motor Co., Inc., 1919 Torrance Blvd., Torrance, California 90501-2746.

Products Covered by Warranty:	Length of Warranty: (from date of original retail purchase)		
	Non Commercial	Commercial/Rental	Local/State/Federal Government
Accessories other than noted below	12 months	3 months	3 months
Emission related accessories: Portable fuel tanks, fuel line assemblies, and water/fuel separators	24 months	24 months	24 months
Replacement Parts	6 months	3 months	3 months

To Qualify for This Warranty:

1. The accessories or replacement parts must be purchased from American Honda or a dealer, distributor, or distributor's dealer authorized by American Honda to sell those products in the United States, Puerto Rico, and the U.S. Virgin Islands. Parts and Accessories must be purchased for installation on original Honda equipment or engines to be eligible for warranty coverage. Installing parts and accessories on non-Honda products or engines voids this warranty.
2. You must be the first retail purchaser. This warranty is not transferable to subsequent owners.

What American Honda Will Repair or Replace Under Warranty:

American Honda will repair or replace, at its option, any

marine product accessories or replacement parts that are proven to be defective in material or workmanship under normal use during the applicable warranty time period. Anything replaced under warranty becomes the property of American Honda Motor Company, Inc. All parts replaced under warranty will be considered as part of the original product and any warranty on those parts will expire coincidentally with the original product warranty.

Accessories and replacement parts, installed by a dealer who is authorized by American Honda to sell them, will be repaired or replaced under warranty without charge for parts or labor. If installed by anyone else, accessories and replacement parts will be repaired or replaced under warranty without charge for parts, but any labor charges will be the responsibility of the purchaser.

CONSUMER INFORMATION

To Obtain Warranty Service:

You must, at your expense, take the Honda Outboard Motor product accessory or replacement part or the outboard motor or boat on which the accessory or replacement part is installed, and proof of purchase to any Honda Marine authorized service facility or dealer in the United States, Puerto Rico, or the U.S. Virgin Islands, during normal business hours.

Exclusions:

This warranty does not extend to accessories or parts affected or damaged by collision, normal wear, use in an application for which the product was not designed or any other misuse, neglect, incorporation or use of unsuitable attachments or parts, unauthorized alteration, improper installation, or any causes other than defects in material or workmanship of the product.

Installing parts and accessories on non-Honda products or engines voids this warranty.

Disclaimer of consequential damage and limitation of implied warranties:

American Honda disclaims any responsibility for loss of time or use of the outboard motor, or the boat on which the product is installed, transportation, commercial loss, or any other incidental or consequential damage. Any implied warranties are limited to the duration of this written warranty. Some states do not allow limitations on

how long an implied warranty lasts and/or do not allow the exclusion or limitation of incidental or consequential damages, so the above exclusions and limitations may not apply to you. This warranty gives you specific legal rights, and you may also have other rights which vary from state to state.

Emission Control System Warranty

Your new Honda outboard engine complies with both the U.S. EPA and State of California emission regulations. American Honda provides the same emission warranty coverage for outboard engines sold in all 50 states. In all areas of the United States your outboard engine must be designed, built, and equipped to meet the U.S. EPA and California Air Resources Board emission standard for spark ignited marine engines.

CALIFORNIA EMISSION CONTROL WARRANTY STATEMENT YOUR WARRANTY RIGHTS AND OBLIGATIONS

The California Air Resources Board (CARB) and American Honda Motor Co., Inc. are pleased to explain the emission control system warranty on your 2013-2014 Honda outboard engine. In California, new outboard engines must be designed, built, and equipped to meet the state's stringent anti-smog standards. American Honda Motor Co., Inc. must warrant the emission control system on your outboard engine for the periods of time listed below provided there has been no

abuse, neglect, or improper maintenance of your outboard engine.

Your emission control system may include parts such as the carburetor or fuel injection system, the ignition system, and catalytic converter. Also included may be hoses, belts, connectors, and other emission-related assemblies.

Where a warrantable condition exists, American Honda Motor Co., Inc. will repair your outboard engine at no cost to you including diagnosis, parts, and labor.

MANUFACTURER'S WARRANTY COVERAGE:

Select emission control parts from model year 2010 and later outboard engines are warranted for five years or 250 hours of use, whichever first occurs; or the length of the Honda Marine Distributor's Limited Warranty, whichever is longer. However, warranty coverage based on the hourly period is only permitted for engines equipped with hour meters as defined in § 2441 (a)(13)* or their equivalent. If any emission-related part on your engine is defective under warranty, the part will be repaired or replaced by American Honda Motor Co., Inc.

* California Code of Regulations.

CONSUMER INFORMATION

OWNER'S WARRANTY RESPONSIBILITIES:

As the outboard engine owner, you are responsible for the performance of the required maintenance listed in your owner's manual. American Honda Motor Co., Inc. recommends that you retain all receipts covering maintenance on your outboard engine, but American Honda Motor Co., Inc. cannot deny warranty solely for the lack of receipts or your failure to ensure the performance of all scheduled maintenance.

As the outboard engine owner, you should, however, be aware that American Honda Motor Co., Inc. may deny you warranty coverage if your outboard engine or a part has failed due to abuse, neglect, improper maintenance, or unapproved modifications.

You are responsible for presenting your outboard engine to a Honda Marine dealer as soon as a problem exists. The warranty repairs will be completed in a reasonable amount of time, not to exceed 30 days.

If you have any questions regarding your warranty rights and responsibilities, you should contact American Honda Motor Co., Inc., Marine Division Customer Relations Office. Please see *Contacting Honda* page 125.

WARRANTY COVERAGE:

Honda outboard engines certified to the CARB and EPA 2010 and later regulation are covered by this warranty to be free from defects for a minimum of five years or 250 hours of operation, whichever comes first; or the length of

the Honda Marine Distributor's Limited Warranty, whichever is longer, from the date of delivery to the retail purchaser. This warranty is transferred to each subsequent purchaser for the duration of the warranty period.

Warranty repairs will be made without charge for diagnosis, parts, and labor. All defective parts replaced under this warranty become the property of American Honda Motor Co., Inc. A list of warranty parts is on page 136. Normal maintenance items, such as spark plugs and filters, that are on the warranted parts list are warranted up to their required replacement interval only.

American Honda Motor Co., Inc. is also liable for damages to other engine components caused by a failure of any warranted part during the warranty period.

Only Honda approved replacement parts will be used in the performance of any warranty repairs, and they will be provided without charge to the owner. You may use any replacement part as defined in § 1900 (b)(20)* in the performance of any maintenance or repairs. If a replacement part is used in the repair or maintenance of your engine, and an authorized Honda Marine dealer determines it causes the failure of a warranted part, your warranty claim may be denied. If the part in question is not related to the reason that your engine requires repair, your claim will not be denied.

* California Code of Regulations.

TO OBTAIN WARRANTY SERVICE:

You must take your Honda outboard engine, along with your sales registration card or other proof of original purchase date, at your expense, to any Honda Marine dealer that is authorized by American Honda Motor Co., Inc. to sell and service that Honda marine product during its normal business hours. Claims for repair or adjustment found to be caused solely by defects in material or workmanship will not be denied because the engine was not properly maintained and used.

If you are unable to obtain warranty service, or are dissatisfied with the warranty service you received, contact the owner of the dealership involved. Normally this should resolve your problem. However, if you require further assistance, write or call the Honda Marine Customer Relations Office of American Honda Motor Co., Inc.

EXCLUSIONS:

Failures other than those resulting from defects in material or workmanship are not covered by this warranty. This warranty does not extend to emission control systems or parts which are affected or damaged by owner abuse, neglect, improper maintenance, misuse, misfueling, improper storage, and/or collision, the incorporation of, or use of, unsuitable attachments, or the unauthorized alteration of any part.

This warranty does not cover replacement of expendable maintenance items made in connection with required maintenance service after the items first scheduled replacement as listed in the maintenance section of the product owner's manual, such as: spark plugs and filters.

DISCLAIMER OF CONSEQUENTIAL DAMAGE AND LIMITATION OF IMPLIED WARRANTIES:

American Honda Motor Co., Inc. disclaims any responsibility for incidental or consequential damages such as loss of time or the use of outboard engine, or any commercial loss due to the failure of the equipment; and any implied warranties are limited to the duration of this written warranty. This warranty is applicable only where the California or U.S. EPA emission control system warranty regulation is in effect.

CONSUMER INFORMATION

EMISSION CONTROL SYSTEM WARRANTY PARTS:

SYSTEMS COVERED BY THIS WARRANTY:	PARTS DESCRIPTION:
Fuel Metering	Carburetor assembly, Throttle body, Fuel injector, Fuel pump, Fuel pressure regulator, Throttle position sensor, Intake air temperature sensor, Engine temperature sensor, Manifold absolute pressure sensor, Idle air control valve, Barometric pressure sensor, Fuel line solenoid valve, Intake manifold, Intake valves, and Oxygen sensor or Air fuel ratio sensor
Evaporative	Portable fuel tank, Fuel cap, Fuel hoses, Primer bulb, Fuel hose joint
Air Induction	Air intake duct, Vapor separator, Intake manifold tuning valve (Intake air bypass control valve)
Ignition	Flywheel magneto, Ignition pulse generator, Ignition coil assembly, Ignition control module, Engine control module, Crankshaft position sensor, Spark plug cap, Spark plug*, Knock sensor, and Camshaft position sensor
Lubrication System	Oil pump and internal parts
Crankcase Emission Control	Crankcase breather tube, Positive crankcase ventilation valve, Oil filler cap
Exhaust	Exhaust manifold and Exhaust valves
Valve Control System	Rocker arm oil control valve
Miscellaneous Parts	Tubing, fittings, seals, gaskets, and clamps associated with these listed systems.
* Covered up to the first required replacement only. See the Maintenance Schedule on pages 72 and 73.	

Canada

Distributor’s Warranty

HONDA CANADA INC., for and on behalf of Honda Motor Co. Ltd., Tokyo, Japan, gives the following written warranty on each new marine product manufactured by Honda Motor Co. Ltd., Japan, distributed in Canada by Honda Canada Inc. and sold by authorized Honda Marine dealers.

Whenever used herein, the word “Honda” refers to Honda Canada Inc. and/or Honda Motor Co. Ltd., as appropriate from the context.

HONDA WARRANTS THAT each new Honda marine product will be free, under normal use and maintenance, from any defects in material or workmanship for the relevant warranty period set forth below. If any defects should be found in a Honda marine product within the relevant warranty period, necessary repairs and replacements with a new part or the Honda equivalent shall be made at no cost to the consumer for parts and labour, when Honda acknowledges that such defects are attributable to faulty material or workmanship at the time of manufacture.

WARRANTY PERIOD RETAILED ON OR AFTER APRIL 1, 2005:

	Non-commercial use	Commercial use
All Honda Outboard Models	36 Months	12 Months

THIS WARRANTY COVERS

- a) Any Honda marine product purchased in Canada from an authorized Honda dealer which has been registered at the time of purchase on a form provided by Honda, which has had set-up and pre-delivery service performed by an authorized Honda dealer and which is normally operated in Canada;
- b) Any factory installed part (except normal maintenance parts referred to in “THIS WARRANTY DOES NOT COVER”); and
- c) Any marine product on which required maintenance services have been performed as prescribed in the Owner’s Manual.

CONSUMER INFORMATION

THIS WARRANTY DOES NOT COVER

- a) Any repairs required as a result of collision, accident, striking any object, misuse or lack of required maintenance;
- b) Any repairs required as a result of any attachments, parts or devices installed by or repairs done by a party other than an authorized Honda dealer;
- c) Any outboard that has been operated out of water, (Run Dry) damaging the water pump and or engine components due to insufficient cooling water.
- d) Any marine products modified, altered, disassembled or remodelled;
- e) Normal maintenance services, including tightening of nuts, bolts and fittings and engine tune-up and the replacement of parts made in connection with normal maintenance services including filters, spark plugs and wires, fuses, belts, lubricants and other expendables susceptible to natural wear;
- f) Outboard propeller or shear pin.
- g) All accessories or attachments.

THE OWNER'S OBLIGATION

In order to maintain the validity of this DISTRIBUTORS WARRANTY, the required maintenance services as set forth in the Owner's Manual must be performed at the proper intervals and detailed receipts and records retained as proof.

TO OBTAIN WARRANTY SERVICE

You must take your Honda marine product, at your expense, during normal service hours, to any authorized Honda Marine dealership. If you are unable to obtain or are dissatisfied with the warranty service you receive, first contact the owner of the dealership involved; this should resolve the problem. If you require further assistance, contact Honda Canada's Customer Relations Department at:

HONDA CANADA INC.
Customer Relations Office
180 Honda Boulevard
Markham, Ontario L6 0H9

TELEPHONE: 1-888-946-6329 TOLL FREE
FAX : 1-877-939-0909 TOLL FREE

REPLACEMENT PARTS AND ACCESSORY WARRANTY

New genuine Honda replacement parts or accessories sold to a consumer or installed by an authorized Honda Marine dealer which are not covered by the DISTRIBUTORS WARRANTY are warranted for a period of one year from date of purchase, provided, however, that this Replacement Parts and Accessory Warranty does not apply to any replacement parts modified, used with, or installed on a marine product for which the replacement parts were not intended. Electrical components that are not installed by the dealer (sold over the counter) are not covered by warranty.

ENTIRE WRITTEN WARRANTY

This DISTRIBUTORS WARRANTY and the REPLACEMENT PARTS AND ACCESSORY WARRANTY are the only and the entire written warranties given by Honda for Marine engines. No dealer or his agent or employee is authorized to extend or enlarge on these warranties on behalf of Honda by any written or verbal statement or advertisement.

DISCLAIMER

To the extent the law permits, Honda disclaims any responsibility for loss of time or use of the product, transportation or towing costs or any other indirect, incidental or consequential damage, inconvenience or commercial loss.

NOTICE TO CONSUMER

The provisions contained in these written warranties are not intended to limit, modify, take away from, disclaim or exclude any warranties set forth in or the operation of The Consumer Products Warranties Act, 1977 (Saskatchewan), The Consumer Product Warranty and Liability Act (New Brunswick), The Consumer Protection Act (Quebec), or any other similar provincial or federal legislation.

INDEX

Anodes	35	CRUISING	62
Replacement	90	Customer Service Information	125
ARE YOU READY TO GET UNDERWAY?	43	Distributor's Limited Warranty	128
ATTACHMENT	38	Distributor's Warranty	137
Automatic Choke (types equipped with electric starter)	35	Electric Starter Button (types equipped with electric starter)	24
BATTERY CONNECTIONS	40	ELECTRIC STARTER WILL NOT OPERATE	100
BATTERY WILL NOT CHARGE AND ELECTRIC STARTER WILL NOT OPERATE	105	EMERGENCY STARTING	54
BEFORE OPERATION	43	Emergency Stop Switch Clip and Emergency Stop Switch	26
BOAT TRANSOM REQUIREMENTS	37	H Type (tiller handle)	22
BREAK-IN PROCEDURE	45	R Type (remote control)	26
Carburetor Modification for High Altitude Operation	112	Emission Control System Information	113
Choke Knob (manual choke type)	22	Engine Cover Latch	30
Choke Knob Friction (manual choke type)	91	REMOVAL AND INSTALLATION	74
CLEANING AND FLUSHING	93	Oil Change	76
COMPONENT AND CONTROL LOCATIONS	17	Level Check	75
CONSUMER INFORMATION	125	Recommendations	79
CONTROL AND FEATURE IDENTIFICATION CODES	13	ENGINE OVERHEATS	104
CONTROLS	22	ENGINE WILL NOT START	101
CONTROLS AND FEATURES	13		
Cooling System Indicator	34		

<p>Fast Idle Lever27</p> <p>Fuel</p> <p style="padding-left: 20px;">Filler Cap Vent Knob36</p> <p style="padding-left: 20px;">Filter Inspection and Replacement87</p> <p style="padding-left: 20px;">Gauge (optional equipment)32</p> <p>HOSE CONNECTIONS48</p> <p>PRIMING48</p> <p style="padding-left: 20px;">Priming Bulb36</p> <p>RECOMMENDATIONS86</p> <p>Fuse Replacement 105</p> <p>Gear Case Oil</p> <p style="padding-left: 20px;">Change80</p> <p style="padding-left: 20px;">Level Check79</p> <p>GEARSHIFT AND THROTTLE OPERATION59</p> <p style="padding-left: 20px;">H Type (tiller handle)59</p> <p style="padding-left: 20px;">R Type (remote control)60</p> <p>Gearshift Lever23</p> <p>Gearshift/Throttle Control Lever28</p> <p>HARD STARTING OR STALLS AFTER</p> <p style="padding-left: 20px;">STARTING 103</p> <p>Honda Publications 125</p> <p>Ignition Switch26</p> <p>IMPORTANT SAFETY INFORMATION 7</p> <p>INDICATORS33</p>	<p>INFREQUENT OR OCCASIONAL USE 49</p> <p>INSTALLATION 37</p> <p>INSTALLATION POSITION 37</p> <p>INSTRUMENTS 32</p> <p>IS YOUR OUTBOARD MOTOR READY TO GO? 43</p> <p>Lubrication Points 82</p> <p>MAINTENANCE SAFETY 70</p> <p>MAINTENANCE SCHEDULE 72</p> <p>Manual Relief Valve (T type) 29, 74</p> <p>MOORING, BEACHING, LAUNCHING 67</p> <p>Oil filter Change 78</p> <p>Oil Pressure Indicator (R type) (H type) 33</p> <p>OIL PRESSURE INDICATOR GOES OFF AND ENGINE SPEED IS LIMITED 106</p> <p>OPERATION 45</p> <p>OTHER FEATURES 35</p> <p>OUTBOARD MOTOR SAFETY 7</p> <p>OVERHEAT AND ENGINE SPEED IS LIMITED ... 107</p> <p>Overheat Indicator (R type) 33</p>
---	--

INDEX

PORTABLE FUEL TANK	36, 47	STEERING	61
Portable Fuel Tank and Tank Filter Cleaning	89	H Type (tiller handle)	61
POWER REQUIREMENTS	37	R Type (remote control)	61
Power Tilt Switch (T type)		Steering Friction Lever	24
H Type (tiller handle)	25	STOPPING THE ENGINE	57
R Type (remote control)	29	Emergency Engine Stopping	57
Propeller Replacement	91	Normal Engine Stopping	57
Recoil Starter Rope Inspection	90	STORAGE	95
REFUELING	84	Engine oil	97
REMOVAL FROM STORAGE	98	Fuel	95
Rev Limiter	35	STORAGE PRECAUTIONS	97
SAFE OPERATING PRECAUTIONS	45	SUBMERGED OUTBOARD MOTOR	109
SAFETY LABEL LOCATIONS	9		
Serial Number Locations	111		
SERVICING YOUR OUTBOARD MOTOR	69		
SHALLOW WATER OPERATION	64		
Spark Plug Service	83		
Specifications	117		
Star Label	115		
Starter Grip	24		
STARTING THE ENGINE	49		
H Type (tiller handle)	49		
R Type (remote control)	52		

Tachometer [optional equipment (R type)]	32
TAKING CARE OF UNEXPECTED PROBLEMS ...	100
TECHNICAL INFORMATION	111
THE IMPORTANCE OF MAINTENANCE	69
Throttle Friction Adjuster	23
Throttle Grip	23
Tilt	
Lever (manual tilt type)	31
Lock Lever (G and T types)	30
TOOL KIT AND EMERGENCY STARTER ROPE	71
Transom Angle Adjusting Rod	30
TRANSOM ANGLE ADJUSTMENT	39, 46
TRANSPORTING	99
WITH OUTBOARD MOTOR INSTALLED	
ON BOAT	99
WITH OUTBOARD MOTOR REMOVED	
FROM BOAT	99
Warranty Statements	128

MEMO

HONDA

The Power of Dreams

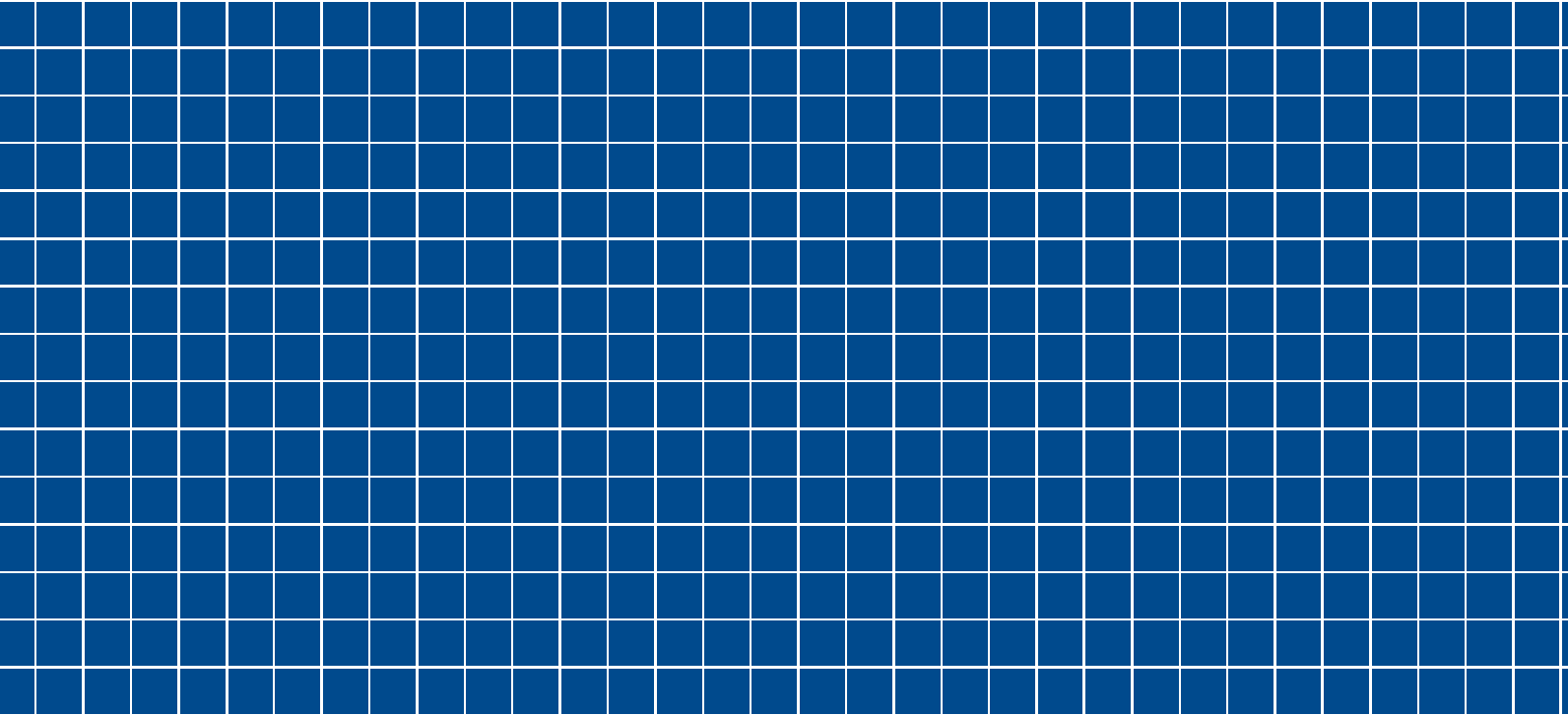

31ZY0633
00X31-ZY0-6330



K3
500.2013.10
Printed in China