

**HONDA**  
**MARINE**

**BF5A**  
**Owner's Manual**

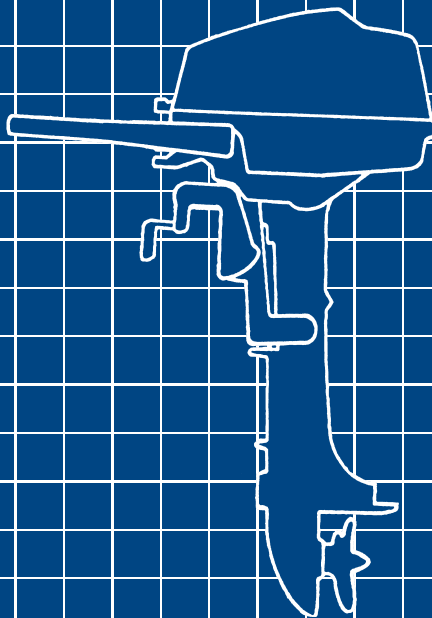

Includes US and Canadian Models



## **WARNING:**



The engine exhaust from this product contains chemicals known to the State of California to cause cancer, birth defects, or other reproductive harm.

Keep this Owner's Manual handy, so you can refer to it at any time. This Owner's Manual is considered a permanent part of the outboard motor and should remain with the outboard motor if resold.

© 2009 Honda Motor Co., Ltd. — All Rights Reserved

The information and specifications included in this publication were in effect at the time of approval for printing. Honda Motor Co., Ltd. reserves the right, however, to discontinue or change specifications or design at any time without notice and without incurring any obligation whatever. No part of this publication may be reproduced without written permission.

# INTRODUCTION

Congratulations on your selection of a Honda outboard motor. We are certain you will be pleased with your purchase of one of the finest outboard motors on the market.

We want to help you get the best results from your new outboard motor and to operate it safely. This manual contains information on how to do that; please read it carefully.

As you read this manual you will find information preceded by a

**NOTICE** symbol. That information is intended to help you avoid damage to your outboard motor, other property, or the environment.

We suggest you read the warranty policy to fully understand its coverage and your responsibilities of ownership (see page 83 ).

When your outboard motor needs scheduled maintenance, keep in mind that your Honda Marine dealer is specially trained in servicing Honda outboard motors. Your Honda Marine dealer is dedicated to your satisfaction and will be pleased to answer your questions and concerns.

Best Wishes,  
Honda Motor Co., Ltd.

# INTRODUCTION

---

## A FEW WORDS ABOUT SAFETY

Your safety and the safety of others are very important. And using this outboard motor safely is an important responsibility.

To help you make informed decisions about safety, we have provided operating procedures and other information on labels and in this manual. This information alerts you to potential hazards that could hurt you or others.

Of course, it is not practical or possible to warn you about all the hazards associated with operating or maintaining an outboard motor. You must use your own good judgment.

You will find important safety information in a variety of forms, including:

- **Safety Labels** — on the outboard motor.
- **Safety Messages** — preceded by a safety alert symbol  and one of three signal words, DANGER, WARNING, or CAUTION.

These signal words mean:

 **DANGER**

You **WILL** be **KILLED** or **SERIOUSLY HURT** if you don't follow instructions.

 **WARNING**

You **CAN** be **KILLED** or **SERIOUSLY HURT** if you don't follow instructions.

 **CAUTION**

You **CAN** be **HURT** if you don't follow instructions.

- **Safety Headings** — such as *IMPORTANT SAFETY INFORMATION*.
- **Safety Section** — such as *OUTBOARD MOTOR SAFETY*.
- **Instructions** — how to use this outboard motor correctly and safely.

This entire book is filled with important safety information — please read it carefully.

# CONTENTS

OUTBOARD MOTOR SAFETY.....	6	INDICATORS.....	18
IMPORTANT SAFETY INFORMATION.....	6	Oil Pressure Indicator.....	18
SAFETY LABEL LOCATIONS.....	8	Cooling System Indicator.....	18
CONTROLS AND FEATURES.....	11	OTHER FEATURES.....	18
CONTROL AND FEATURE		Rev Limiter.....	18
IDENTIFICATION CODES.....	11	Anode.....	19
COMPONENT AND CONTROL LOCATIONS.....	12	Portable Fuel Tank.....	19
CONTROLS.....	14	Fuel Filler Cap Vent Knob.....	19
Emergency Stop Switch Clip and Emergency		Fuel Priming Bulb.....	20
Stop Switch.....	14	INSTALLATION.....	21
Choke Knob.....	14	POWER REQUIREMENTS.....	21
Throttle Grip.....	15	INSTALLATION POSITION.....	21
Throttle Friction Knob.....	15	ATTACHMENT.....	22
Gearshift Lever.....	15	TRANSOM ANGLE ADJUSTMENT.....	22
Starter Grip.....	16	BEFORE OPERATION.....	23
Engine Cover Lock Lever.....	16	ARE YOU READY TO GET UNDER WAY?.....	23
Transom Angle Adjusting Rod.....	16	IS YOUR OUTBOARD MOTOR	
Steering Friction Bolt.....	17	READY TO GO?.....	23
Tilt Lever.....	17		
INSTRUMENTS.....	17		
Fuel Gauge.....	17		

# CONTENTS

---

OPERATION .....	25	SERVICING YOUR OUTBOARD MOTOR.....	38
SAFE OPERATING PRECAUTIONS .....	25	THE IMPORTANCE OF MAINTENANCE.....	38
BREAK-IN PROCEDURE.....	25	MAINTENANCE SAFETY .....	39
TRANSOM ANGLE ADJUSTMENT .....	25	TOOL KIT AND EMERGENCY STARTER	
PORTABLE FUEL TANK.....	26	ROPE.....	40
FUEL HOSE CONNECTIONS.....	26	MAINTENANCE SCHEDULE .....	41
FUEL PRIMING.....	27	ENGINE COVER REMOVAL AND	
STARTING THE ENGINE .....	27	INSTALLATION.....	43
EMERGENCY STARTING.....	29	Engine Oil Level Check.....	43
STOPPING THE ENGINE.....	32	Engine Oil Change.....	44
Emergency Engine Stopping .....	32	Engine Oil Recommendations .....	45
Normal Engine Stopping.....	32	Gear Case Oil Level Check.....	45
GEARSHIFT AND THROTTLE OPERATION .....	33	Gear Case Oil Change.....	46
STEERING .....	34	Lubrication Points .....	48
CRUISING .....	35	Spark Plug Service.....	49
SHALLOW WATER OPERATION.....	36	REFUELING.....	50
MOORING, BEACHING, LAUNCHING.....	37	FUEL RECOMMENDATIONS.....	51
		Fuel Filter Inspection and Replacement .....	52
		Portable Fuel Tank and Tank Filter Cleaning.....	54
		Recoil Starter Rope Inspection .....	55
		Anode Replacement.....	55
		Propeller and Shear Pin Replacement.....	56

# CONTENTS

STORAGE .....	58	TECHNICAL AND CONSUMER INFORMATION...	73
STORAGE PREPARATION .....	58	TECHNICAL INFORMATION .....	73
Cleaning and Flushing .....	58	Serial Number locations .....	73
Fuel .....	60	Carburetor Modification for High Altitude	
Engine Oil .....	62	Operation .....	74
STORAGE PRECAUTIONS .....	62	Emission Control System Information .....	75
REMOVAL FROM STORAGE .....	63	Star Label .....	77
		Specifications .....	79
TRANSPORTING .....	64	CONSUMER INFORMATION .....	80
WITH OUTBOARD MOTOR INSTALLED		Honda Publications .....	80
ON BOAT .....	64	Customer Service Information .....	80
WITH OUTBOARD MOTOR REMOVED		Warranty Statements .....	83
FROM BOAT .....	64	Distributor's Limited Warranty .....	83
		Emission Control System Warranty .....	87
		Distributor's Warranty .....	91
TAKING CARE OF UNEXPECTED			
PROBLEMS .....	65	INDEX .....	94
ENGINE WILL NOT START .....	65		
HARD STARTING OR STALLS AFTER			
STARTING .....	67		
ENGINE OVERHEATS .....	68		
ENGINE WILL NOT DRIVE THE PROPELLER...	69		
OIL PRESSURE INDICATOR GOES OFF AND			
ENGINE SPEED IS LIMITED .....	70		
SUBMERGED MOTOR .....	71		

# OUTBOARD MOTOR SAFETY

## IMPORTANT SAFETY INFORMATION

The Honda BF5A outboard motor is designed for use with boats that have a suitable manufacturer's power recommendation. Other uses can result in injury to the operator or damage to the outboard motor and other property.

Most injuries or property damage can be prevented if you follow all instructions in this manual and on the outboard motor. The most common hazards are discussed in this chapter, along with the best way to protect yourself and others.

## Operator Responsibility

- It is the operator's responsibility to provide the necessary safeguards to protect people and property. Know how to stop the engine quickly in case of emergency. Understand the use of all controls.
  - Stop the engine immediately if anyone falls overboard, and do not run the engine while the boat is near anyone in the water.
  - Always stop the engine if you must leave the controls for any reason.
- Attach the emergency stop switch lanyard securely to the operator.
  - Always wear a PFD (Personal Flotation Device) while on the boat.
  - Familiarize yourself with all laws and regulations relating to boating and the use of outboard motors.
  - Be sure that anyone who operates the outboard motor receives proper instruction.
  - Be sure the outboard motor is properly mounted on the boat.
  - Do not remove the engine cover while the engine is running.



## Refuel With Care

- Gasoline is extremely flammable, and gasoline vapor can explode. Refuel outdoors, in a well-ventilated area, with the engine stopped. Never smoke near gasoline, and keep other flames and sparks away.
- Remove any portable fuel tank from the boat for refueling. Keep the portable fuel tank away from the battery or other potential spark sources.
- Refuel carefully to avoid spilling fuel. Avoid overfilling the fuel tank.
- After refueling, tighten the filler cap securely. If any fuel is spilled, make sure the area is dry before starting the engine.

## Carbon Monoxide Hazard

Exhaust contains poisonous carbon monoxide, a colorless, odorless gas. Breathing carbon monoxide can cause loss of consciousness and may lead to death.

If you run the engine in an area that is confined, or even partly enclosed, the air you breathe could contain a dangerous amount of exhaust gas.

Never run your outboard inside a garage or other enclosure.

# OUTBOARD MOTOR SAFETY

## SAFETY LABEL LOCATIONS US, Puerto Rico, and US Virgin Islands Types

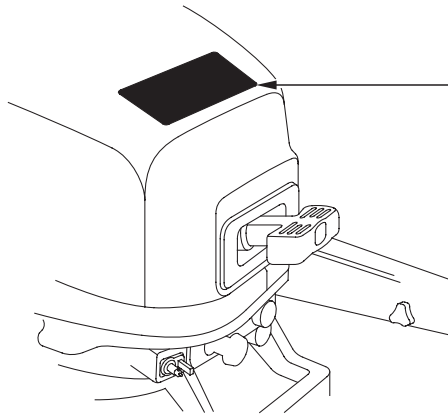

 READ OWNER'S MANUAL CAREFULLY BEFORE OPERATION.
<b>⚠ WARNING</b>
<ul style="list-style-type: none"><li>■ PLACE TRANSMISSION IN NEUTRAL BEFORE STARTING.</li><li>■ DO NOT OPERATE WITH ENGINE COVER REMOVED.</li><li>■ BE SURE THE ANTIVENTILATION PLATE IS BELOW THE WATER LINE.</li><li>■ DO NOT SHIFT TO REVERSE SUDDENLY AT HIGH SPEED.</li></ul>
<ul style="list-style-type: none"><li>■ CHECK OIL LEVEL BEFORE STARTING.</li><li>■ FLUSH THE SYSTEM THOROUGHLY WITH FRESH WATER AFTER EACH USE IN SALT WATER.</li></ul>

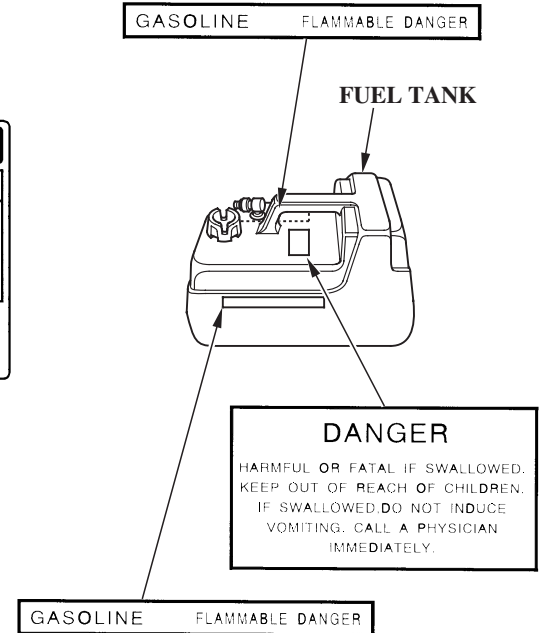

The labels shown here contain important safety information. Please read them carefully. These labels are considered permanent parts of your outboard motor. If a label comes off or becomes hard to read, contact an authorized Honda Marine dealer for a replacement.

# OUTBOARD MOTOR SAFETY

## Canadian Types



Ⓢ DO NOT SHIFT TO REVERSE SUDDENLY AT HIGH SPEED.  
 Ⓢ BEI HOHER FAHRGESCHWINDIGKEIT AUF KEINEN FALL PLÖTZLICH DEN RÜCKWÄRTSGANG EINLEGEN.  
 Ⓢ NE PAS ENGAGER LA MARCHÉ ARRÈRE BRUSQUEMENT À GRANDE VITESSE.  
 Ⓢ BJI HOGE SNEIHELIED NIET PLOTSELING IN DE ACHTERUIT-VERSNIJLING SCHAKELEN.  
 Ⓢ NON INGRANATE IMPROVVISAMENTE LA RETROMARCIA AD ALTA VELOCITÀ.  
 Ⓢ NO PONER LA MARCHA ATRÁS DE REPENTE CUANDO CIRCOLE A ALTA VELOCIDAD.  
 Ⓢ NÃO MUDAR REPTENIVAMENTE PARA MARCHA ATRÁS A ALTA VELOCIDADE.  
 Ⓢ ÄLÄ VÄHÄÄ ÄKILLIESTI PERUUTUSVÄHTEELLE NOIREASSA VAHIOSSA.  
 Ⓢ GRIET MÅ IKKE SETTES I REVERS NÅR DET KJØRES MED HØY HASTIGHET.  
 Ⓢ LÄGG RITE PLOTSLET IN BACKEN VID KÖRNING PÅ HÖG HASTIGHET.  
 Ⓢ 고속에서 갑자기 후진으로 전환하지 마십시오.

## READ OWNER'S MANUAL

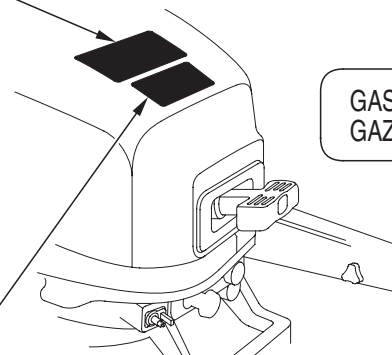

**GASOLINE FLAMMABLE DANGER  
GAZOLINE INFLAMMABLE DANGEREUX**

## FUEL CAUTION

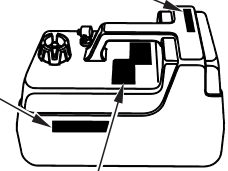

**CAUTION**  
KEEP TOTALLY CLOSED WHEN NOT IN USE. KEEP AWAY FROM HEAT, SPARKS, AND OPEN FLAME.  
"SECURE ABOVE DECK IN WELL VENTILATED AREA." "DO NOT USE FOR LONG TERM FUEL STORAGE."

**DANGER**  
HARMFUL OR FATAL IF SWALLOWED. KEEP OUT OF REACH OF CHILDREN. IF SWALLOWED, DO NOT INDUCE VOMITING. CALL A PHYSICIAN IMMEDIATELY.

The labels shown here contain important safety information. Please read them carefully. These labels are considered permanent parts of your outboard motor. If a label comes off or becomes hard to read, contact an authorized Honda Marine dealer for a replacement.

# OUTBOARD MOTOR SAFETY

## Canadian Types



- Honda outboard motor is designed to give safe and dependable service if operated according to instructions. Read and understand the Owner's Manual before operating the outboard motor. Failure to do so could result in personal injury or equipment damage.



- Gasoline is harmful or fatal if swallowed. Keep the fuel tank out of reach of children.
- Gasoline is extremely flammable and is explosive under certain conditions. Refuel in a well-ventilated area with the engine stopped.
- Do not smoke or allow flames or sparks where the engine is refueled or where gasoline is stored.
- Do not overfill the fuel tank. After refueling make sure that the fuel filler cap is closed properly and securely.

- Be careful not to spill any fuel while refueling. Spilled fuel or fuel vapor may ignite. If any fuel is spilled, make sure that the area is dry before starting the engine.

# CONTROLS AND FEATURES

## CONTROL AND FEATURE IDENTIFICATION CODES

Model	BF5A	
Type	SA SC	LA LC
Shaft Length	S	●
	L	●

Refer to this chart for an explanation of the Type Codes used in this manual to identify control and feature applications.

BF5A is provided with the following types according to the shaft length.

- Shaft Length  
S: Short Shaft  
L: Long Shaft

(Example)

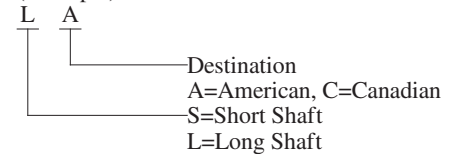

# CONTROLS AND FEATURES

## COMPONENT AND CONTROL LOCATIONS

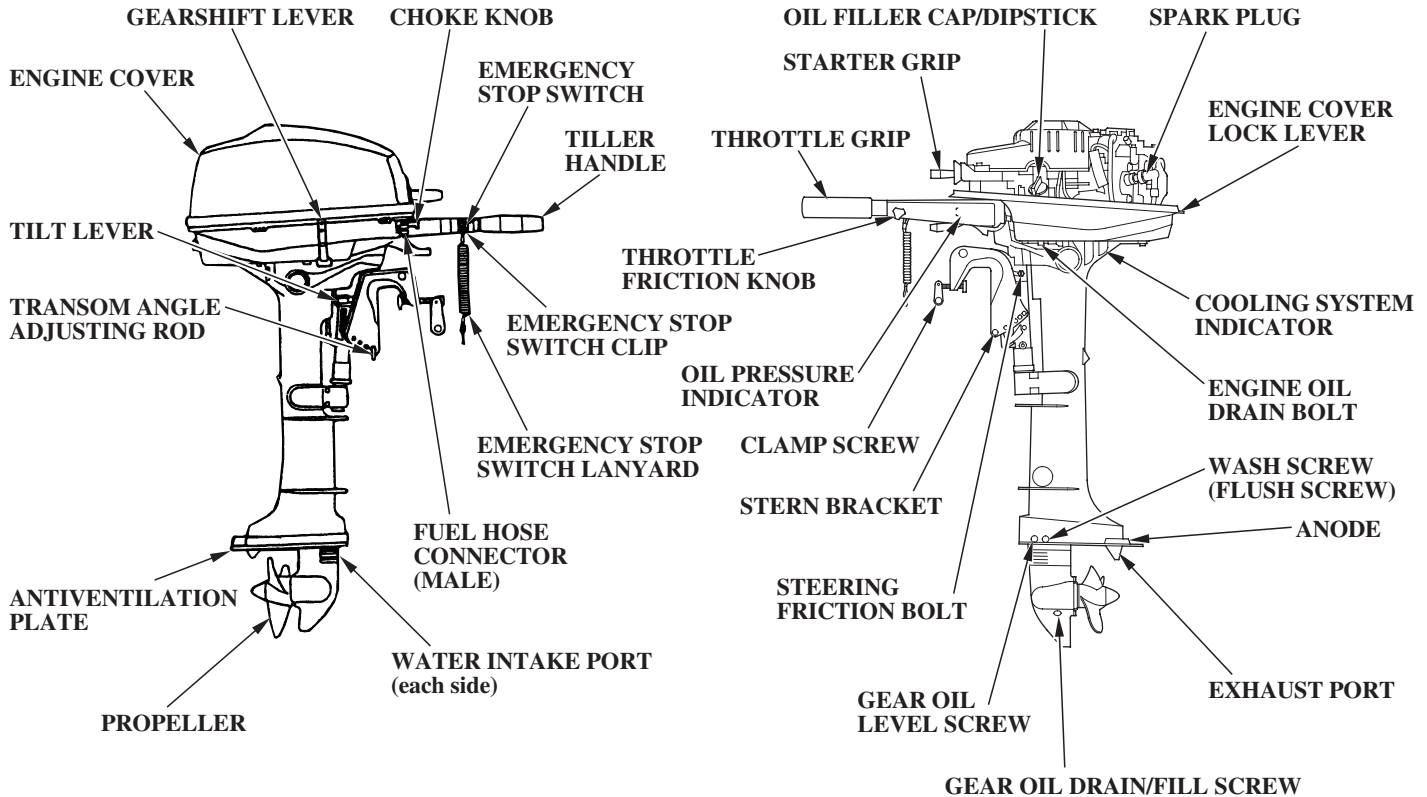

**Portable Fuel Tank**

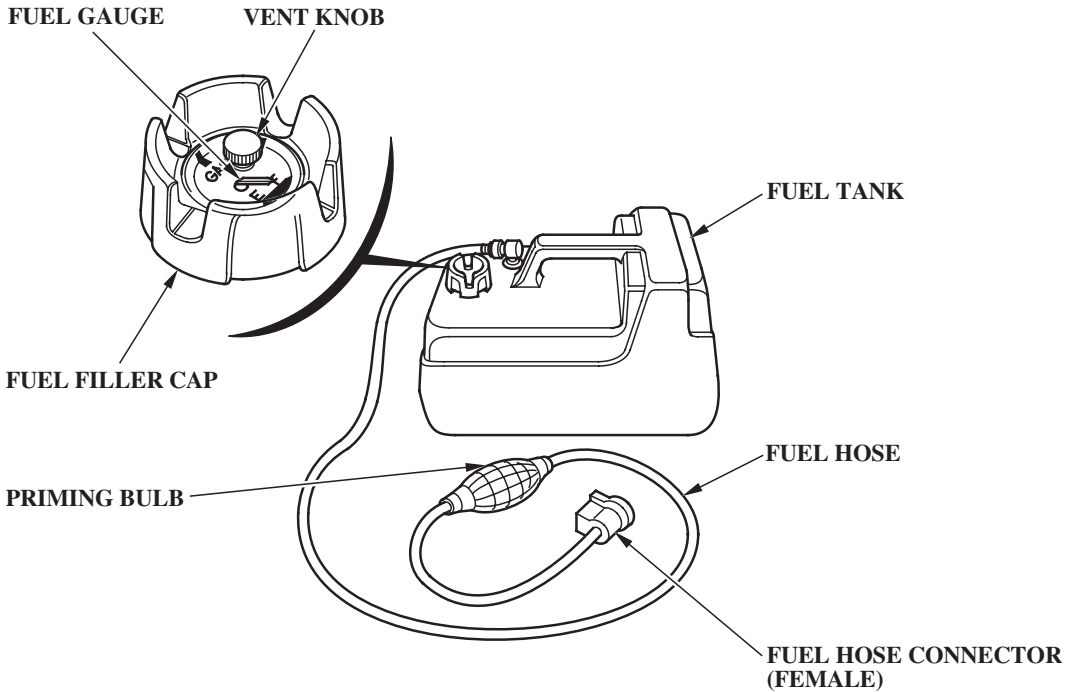

# CONTROLS AND FEATURES

## CONTROLS

### Emergency Stop Switch Clip and Emergency Stop Switch

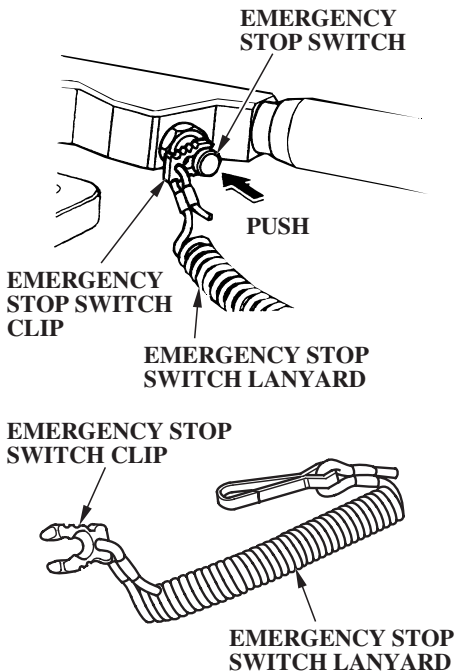

The emergency stop switch clip must be inserted in the emergency stop switch in order for the engine to start and run. The emergency stop switch lanyard must be attached securely to the operator or to the operator's PFD (Personal Flotation Device).

When used as described, the emergency stop switch and emergency stop switch lanyard system stops the engine if the operator falls away from the controls.

A spare emergency stop switch clip is supplied with the tool kit.

### Choke Knob

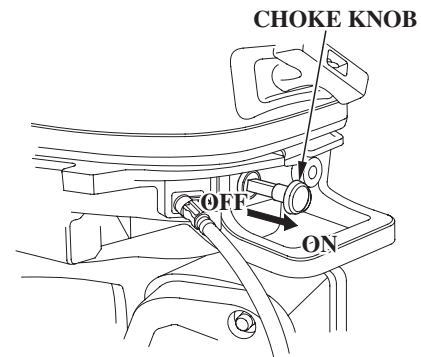

The choke knob opens and closes the choke valve in the carburetor.

The ON position enriches the fuel mixture for starting a cold engine.

The OFF position provides the correct fuel mixture for operation after starting, and for restarting a warm engine.



## Throttle Grip

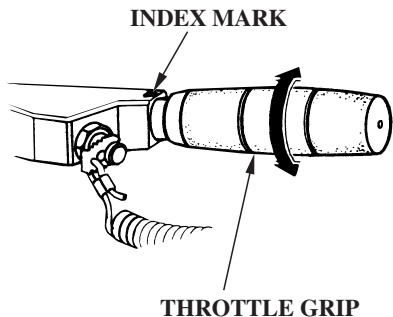

The throttle grip controls engine speed.

An index mark on the tiller handle shows throttle position and is helpful for setting the throttle correctly when starting (p. 28).

## Throttle Friction Knob

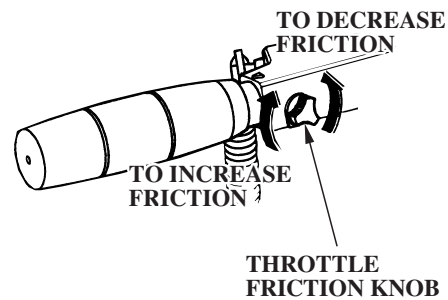

The throttle friction knob adjusts resistance to throttle grip rotation.

Turn the knob clockwise to increase friction for holding a throttle setting while cruising.

Turn the knob counterclockwise to decrease friction for easy throttle grip rotation.

## Gearshift Lever

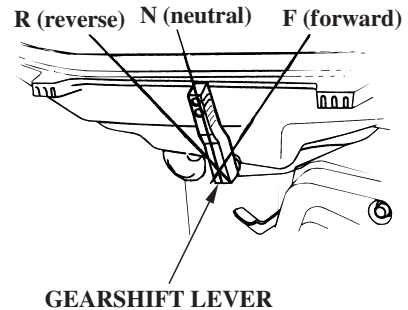

The gearshift lever is used to select F (forward), N (neutral), or R (reverse) gears.

The engine can be started with the gearshift lever in the N (neutral) position only.

If the gearshift lever is in the F (forward) or R (reverse) position, the recoil starter will not operate.

# CONTROLS AND FEATURES

## Starter Grip

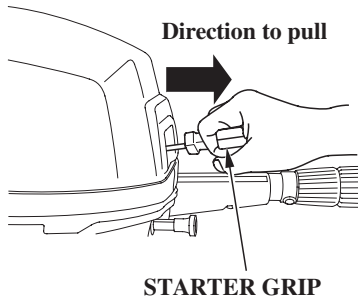

Pulling the starter grip operates the recoil starter to crank the engine for starting.

The motor will start only when the gearshift lever (p. 28 ) is in the N (neutral) position, and the emergency stop switch clip is in the emergency stop switch.

## Engine Cover Lock Lever

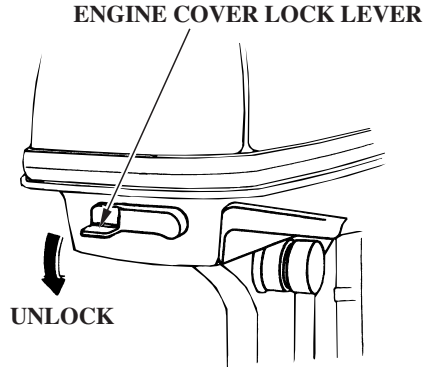

The engine cover lock lever fastens the engine cover to the outboard motor.

## Transom Angle Adjusting Rod

The transom angle adjusting rod adjusts the transom angle of the outboard motor when fully lowered.

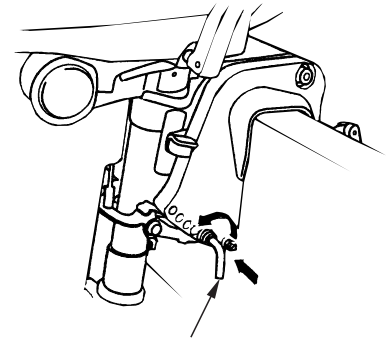

Proper adjustment prevents the outboard motor from being adjusted too low (p. 35 ).

## Steering Friction Bolt

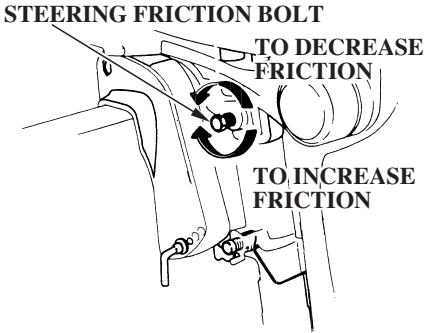

The steering friction bolt adjusts steering resistance.

Less friction allows the outboard motor to turn more easily. More friction helps to hold a steady course while cruising or to prevent the outboard motor from swinging while trailering the boat.

## Tilt Lever

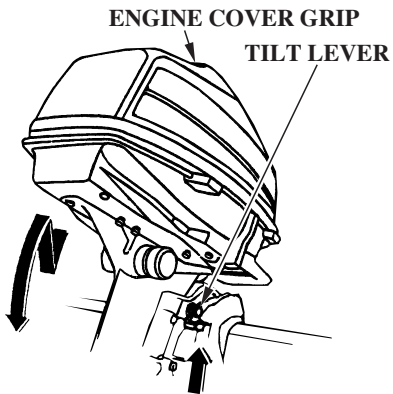

The tilt lever enables the outboard motor to be raised for shallow water operation, beaching, launching, or mooring.

To tilt, raise the outboard motor by pulling on the cover grip until the tilt mechanism engages at 18°, 38°, or 58° (p. 36 and 37).

## INSTRUMENTS

### Fuel Gauge

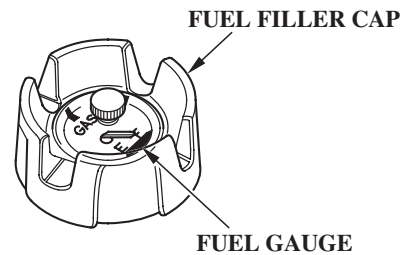

A fuel gauge is built into the cap of the portable fuel tank.

# CONTROLS AND FEATURES

---

## INDICATORS

### Oil Pressure Indicator

#### OIL PRESSURE INDICATOR

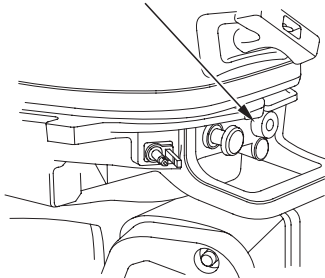

When the oil pressure indicator is lit, oil pressure is OK.

If oil pressure becomes low, the oil pressure indicator will go off, and the engine protection system will limit engine speed. Refer to *TAKING CARE OF UNEXPECTED PROBLEMS*, p. 70 .

Low oil pressure indicates that the engine oil level is low or that there is a problem with the engine lubrication system.

### Cooling System Indicator

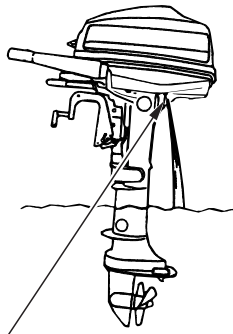

#### COOLING SYSTEM INDICATOR

Water should flow from the cooling system indicator while the engine is running. This shows that water is circulating through the cooling system.

If water stops flowing while the engine is running, that indicates a cooling system problem, such as clogged water intakes, which will cause engine overheating.

## OTHER FEATURES

### Rev Limiter

The engine is equipped with an rev limiter to prevent the possibility of mechanical damage from excessive engine speed.

The rev limiter may be activated during operation, limiting engine speed, if the outboard motor is tilted excessively, or when propeller ventilation occurs during a sharp turn.

If the rev limiter is activated, check the tilt angle of the outboard motor.

Improper propeller selection may also cause the rev limiter to activate.

Check to see if the correct propeller is installed.

## Anode

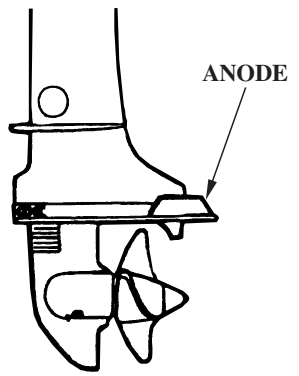

The anode is made of a sacrificial material that helps to protect the outboard motor from corrosion.

There is an anode on the antiventilation plate.

## Portable Fuel Tank

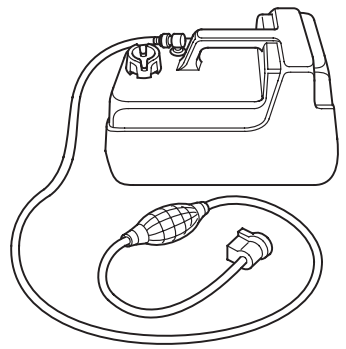

The portable fuel tank has a capacity of 3.2 US gal (12L) and has a fuel gauge built into the cap.

## Fuel Filler Cap Vent Knob

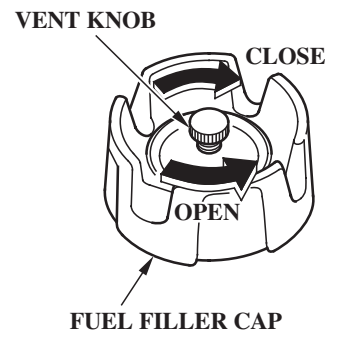

The fuel filler cap is provided with a vent knob to seal the portable fuel tank for carrying it to and from the boat. Open the vent knob 2 or 3 turns before starting the engine.

# CONTROLS AND FEATURES

---

## Fuel Priming Bulb

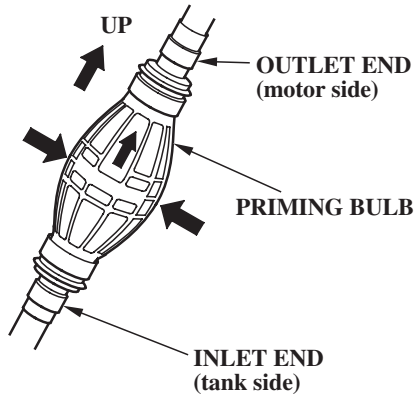

A priming bulb is built into the fuel hose that connects the fuel tank to the outboard motor.

Before starting the engine, hold the priming bulb up in the direction of the arrow, then squeeze the priming bulb until it feels firm. This will ensure that fuel is supplied to the engine.

# INSTALLATION

Correct and secure installation is essential for safe boating and good performance. Follow the installation instructions provided in this manual.

## POWER REQUIREMENTS

Before installation, check to be sure that the outboard motor does not exceed the recommended maximum horsepower for the boat on which it is to be installed. Refer to the boat's certification plate for recommended maximum horsepower. If the certification plate information is not available, contact the boat dealer or manufacturer.

For most applications, the outboard motor should have a horsepower rating which provides 80% of the maximum recommended horsepower for the boat.

## INSTALLATION POSITION

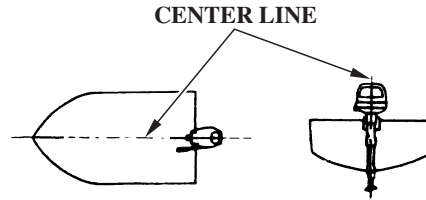

Install the outboard motor on the center of the boat transom.

The antiventilation plate of the outboard motor should be 0 – 2 in (0 – 50 mm) below the bottom of the boat.

The correct dimensions differ according to the type of boat and the configuration of the bottom of the boat. Follow the manufacturer's recommended installation height.

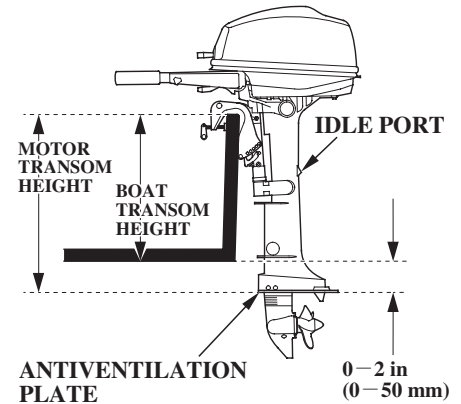

Type:	Motor Transom Height
S:	17.1 in (434 mm)
L:	22.1 in (561 mm)

When the outboard motor is installed extremely low, the idle port may be immersed and the engine may become hard to start or may run poorly. Check that the idle port is high enough from the water level when the engine is stopped with the boat fully loaded.

## INSTALLATION

If the outboard motor is installed too low, the boat will squat and be hard to plane, and the motor will spray water that may enter the boat. It will tend to porpoise, and high-speed stability will be reduced.

If the outboard motor is installed too high, that will cause propeller ventilation.

Optimum installation height varies with boat type and bottom shape. Contact the boat manufacturer for any special recommendations that are unique to a specific model of boat.

If the transom needs to be modified to accommodate the outboard motor, contact the boat manufacturer and follow their recommendations for corrective action.

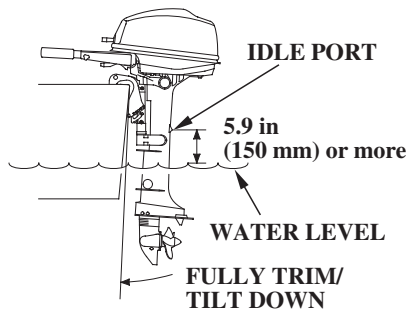

Adverse effect to the engine can occur if the installation position of the outboard motor is too low. Trim/tilt down the outboard motor with the boat fully loaded and stop the engine. Check that the idle port is 5.9 in (150 mm) or more above the water level.

## ATTACHMENT

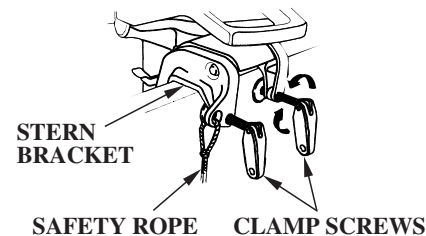

Attach the stern bracket to the boat transom by tightening the clamp screws.

Attach a rope from the boat to the hole in the stern bracket. This will help to prevent accidental loss of the outboard motor.

## TRANSOM ANGLE ADJUSTMENT

Use the transom angle adjustment rod (p. 25) to adjust the angle of the outboard motor so the propeller is perpendicular to the surface of the water.



## BEFORE OPERATION

### ARE YOU READY TO GET UNDERWAY?

Your safety is your responsibility. A little time spent in preparation will significantly reduce your risk of injury.

### Knowledge

Read and understand this manual. Know what the controls do and how to operate them.

Familiarize yourself with the outboard motor and its operation before you get underway. Know what to do in case of an emergency.

Familiarize yourself with all laws and regulations relating to boating and the use of outboard motors.

### Safety

Always wear a PFD (Personal Flotation Device) while on the boat.

Attach the emergency stop switch lanyard securely to the operator or to the operator's PFD.

### IS YOUR OUTBOARD MOTOR READY TO GO?

For your safety, and to maximize the service life of your equipment, it is very important to take a few moments before you operate the outboard motor to check its condition. Be sure to take care of any problem you find, or have your authorized Honda Marine dealer correct it, before you operate the outboard motor.

### WARNING

Improperly maintaining this outboard motor or failing to correct a problem before operation can cause a malfunction in which you could be seriously hurt or killed.

Always perform a pre-operation inspection before each operation, and correct any problem.

Before beginning your pre-operation checks, be sure the emergency stop switch clip is removed from the emergency stop switch.

# BEFORE OPERATION

---

## Safety Inspection

- Look around the outboard motor for signs of oil or gasoline leaks.
- If you are using the portable fuel tank, make sure it is in good condition and properly secured in the boat (p. 26).
- Check that the fuel hose is undamaged and properly connected (p. 26).
- Wipe up any spills before starting the engine.
- Check the stern bracket to be sure the outboard motor is securely installed.
- Check that all controls are operating properly.
- Replace any damaged parts.
- Check that all fasteners are in place and securely tightened.

- Check the emergency stop switch for proper operation (p. 14, 27). Start the engine (p. 27). Make sure the engine stops by pulling the emergency stop switch clip from the emergency stop switch (p. 32).

## Maintenance Inspection

- Check the engine oil level (p. 43). Running the engine with a low oil level can cause engine damage.
- Check to be sure the propeller and shear pin are undamaged (p. 56).
- Check that the anode is securely attached to the antiventilation plate (p. 55) and is not excessively worn. The anode helps to protect the outboard motor from corrosion.
- Make sure the tool kit and emergency starter rope are onboard (p. 40). Replace any missing items.

- Check the fuel level in the fuel tank (p. 50).

# OPERATION

## SAFE OPERATING PRECAUTIONS

To safely realize the full potential of this outboard motor, you need a complete understanding of its operation and a certain amount of practice with its controls.

Before operating the outboard motor for the first time, please review the *IMPORTANT SAFETY INFORMATION* on page 6 and the chapter titled *BEFORE OPERATION*.

For your safety, do not start or run the engine in a confined or partly enclosed area. Your engine's exhaust contains poisonous carbon monoxide, a colorless, odorless gas that can collect rapidly. Breathing carbon monoxide can cause loss of consciousness and may lead to death.

## BREAK-IN PROCEDURE

Proper break-in procedure allows the moving parts to wear in smoothly for best performance and long service life.

For the first 10 hours, run the outboard motor at low speed, and avoid full-throttle operation.

## TRANSOM ANGLE ADJUSTMENT

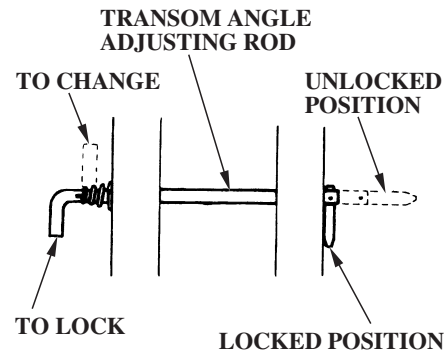

The transom angle adjusting rod is used to adjust the angle of the outboard motor in the normal operating position (p. 35).

1. To adjust, first tilt the outboard motor so it is not resting on the rod.
2. Push the rod in and turn the end of the rod up, so the latch will fall into line with the rod.
3. Remove the rod and reinsert it in the desired position.
4. Push the rod in and turn the end of the rod down, so the latch will fall to the locked position. Then release the rod.

# OPERATION

## PORTABLE FUEL TANK

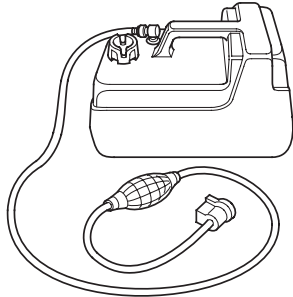

Place the portable fuel tank in a well-ventilated location, away from direct sunlight, to reduce the possibility of a gasoline vapor explosion.

To ensure that the outboard motor will be able to draw fuel from the tank, place the tank within 6 feet (2 m) of the outboard motor and not more than 3 feet (1 m) below the fuel connector on the outboard motor.

Secure the portable fuel tank in the boat so that it won't move around and become damaged.

Before use, open the fuel tank vent by turning the vent knob at least 2 or 3 turns counterclockwise.

### **⚠ WARNING**

Gasoline is highly flammable and explosive.

You can be burned or seriously injured when handling fuel.

- Stop the engine and keep heat, sparks, and flame away.
- Handle fuel only outdoors.
- Wipe up spills immediately.

## FUEL HOSE CONNECTIONS

### FUEL HOSE CONNECTOR

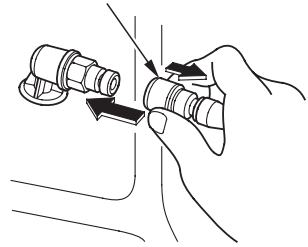

(FUEL TANK SIDE)

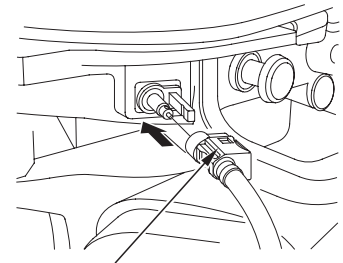

FUEL HOSE CONNECTOR

(OUTBOARD MOTOR SIDE)

Connect the fuel hose to the tank and the outboard motor, as shown. Be sure both connectors snap securely into place.

**FUEL PRIMING**

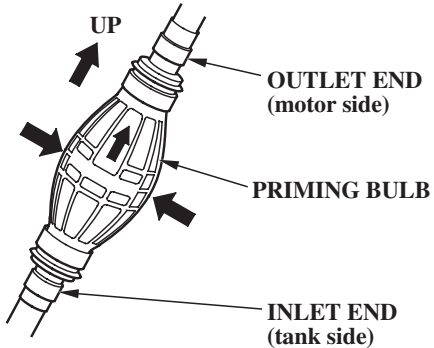

Hold the priming bulb up in the direction of the arrow; then squeeze the priming bulb several times until it feels firm, indicating that fuel has reached the engine.

Check to be sure there are no fuel leaks before starting the engine.

Do not touch the priming bulb with the engine running or when tilting up the outboard motor. The carburetor could overflow.

**STARTING THE ENGINE**

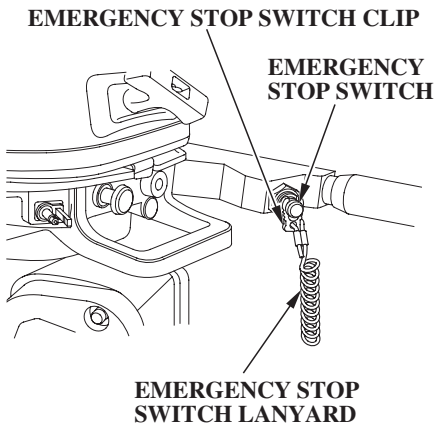

1. Put the emergency stop switch clip in the emergency stop switch, and attach the emergency stop switch lanyard securely to the operator or to the operator's PFD (Personal Flotation Device).

The engine will not start or run unless the emergency stop switch clip is in the emergency stop switch.

The emergency stop switch clip and emergency stop switch lanyard system is a safety device that will stop the engine if you fall away from the controls while operating the boat.

Always attach the emergency stop switch lanyard securely to the operator or to the operator's PFD before starting the engine.

# OPERATION

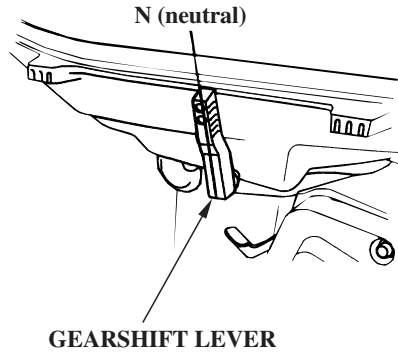

2. Check the position of the gearshift lever. It must be in the N (neutral) position for starting.

The engine will not start if the gearshift lever is in the F (forward) or R (reverse) position.

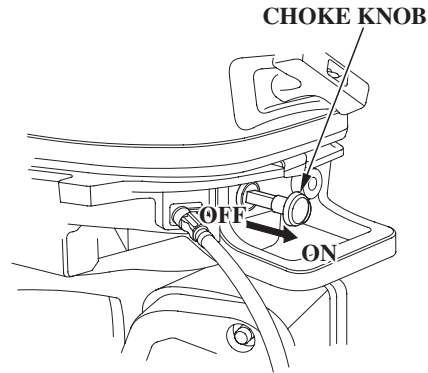

3. To start a cold engine, pull the choke knob to the ON position. To restart a warm engine, leave the choke knob in the OFF position.

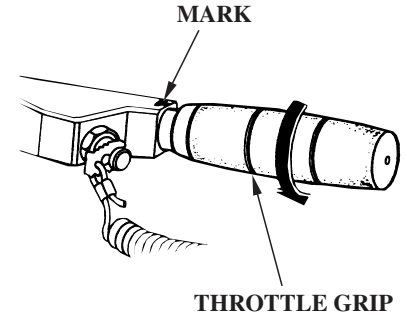

4. Align the START position with the mark for starting the engine.

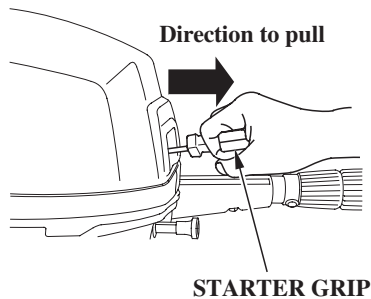

5. Pull the starter grip lightly until you feel resistance, then pull briskly in the direction of the arrow as shown above.

Return the starter grip gently.

6. If the choke knob was pulled to the ON position to start the engine, gradually push it to the OFF position as the engine warms up.

Also, as the engine warms up, the throttle grip can be turned to the SLOW position without stalling.

7. Before getting underway, allow the engine to warm-up sufficiently to ensure good performance.

During the warm-up period, check the oil pressure indicator (p. 18 ) and cooling system indicator (p. 18 ).

If the indicators show any abnormal condition, immediately stop the engine and determine the cause of the problem. Refer to *TAKING CARE OF UNEXPECTED PROBLEMS* on p. 68 and 70 .

## EMERGENCY STARTING

If the recoil starter is inoperative, you can start the engine manually using the emergency starter rope supplied with the tool kit.

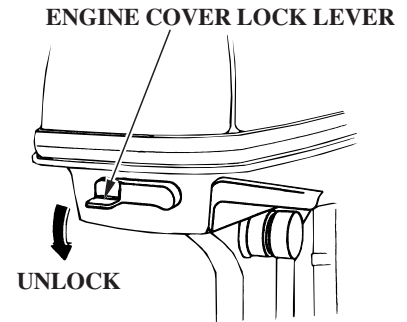

1. Unlock and remove the engine cover.

## OPERATION

6 mm CAP NUTS

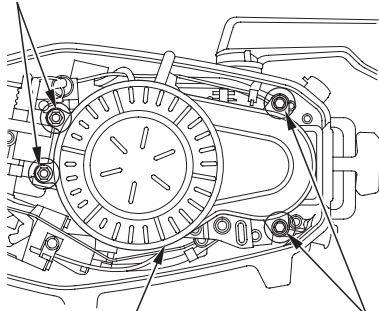

6 mm FLANGE  
BOLTS

FLYWHEEL COVER

2. Remove the two 6 mm cap nuts and 6 mm flange bolts, and remove the flywheel cover.

3. Set the controls the same as for normal starting (see pages 27 — 28 ). Use the choke control if needed.
4. Set the knotted end of the emergency starter rope in the notch in the flywheel. Wind the rope clockwise around the flywheel.

EMERGENCY STARTER ROPE

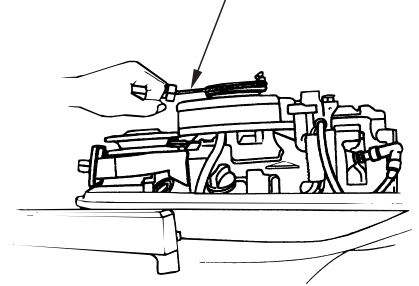

5. Pull the emergency starter rope slowly until resistance is felt, then pull briskly.

Keep away from moving parts while pulling the rope.

If necessary, rewind the rope and pull again. If the engine does not start after several attempts, refer to *TAKING CARE OF UNEXPECTED PROBLEMS*, p. 65 .



6. If the choke control was used to start the engine, return the control to the normal operating position as the engine warms up.

During the warm-up period, check the oil pressure indicator (p. 18), and cooling system indicator (p. 18).

7. Install the engine cover (p. 43), and lock it in place by locking the engine cover lock lever.

### **WARNING**

Exposed moving parts can cause injury.

- Do not operate the outboard motor without the engine cover.
- Use extreme care when installing the engine cover.

8. If it was necessary to remove the emergency stop switch lanyard from you to perform the emergency starting procedure, be sure the lanyard is attached securely to operator before operating the outboard motor.
9. Have your closest authorized Honda Marine dealer check your system and correct the problem, so you can use the recoil starter.

# OPERATION

## STOPPING THE ENGINE

### Emergency Engine Stopping

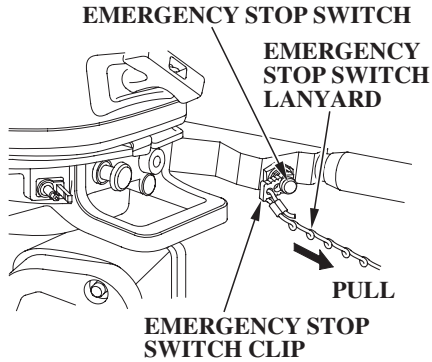

To stop the engine in an emergency, pull the emergency stop switch clip out of the emergency stop switch by pulling the emergency stop switch lanyard.

We suggest that you stop the engine this way occasionally to verify that the engine and emergency stop switch are operating properly.

### Normal Engine Stopping

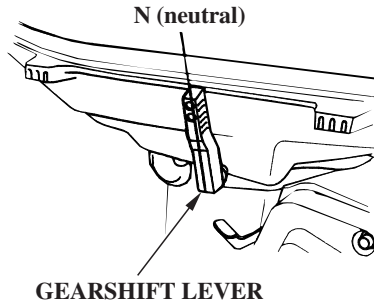
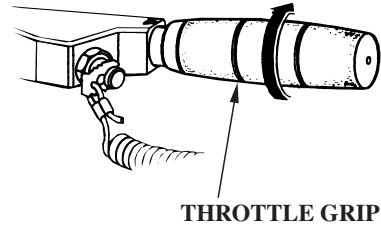

1. Move the throttle grip to the slowest speed and gearshift lever to the N (neutral) position.

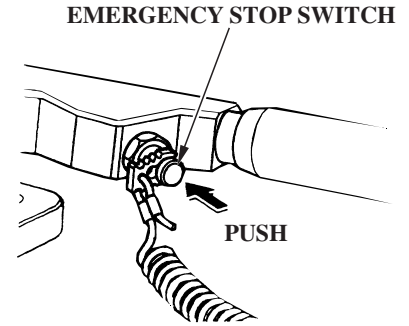

After cruising at full throttle, cool down the engine by idling for a few minutes before stopping the engine.

2. Press the emergency stop switch until the engine stops.
3. When the boat is not in use, remove and store the emergency stop switch clip and lanyard.

**GEARSHIFTING AND THROTTLE OPERATION**

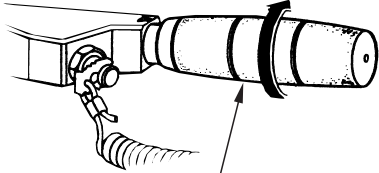

**THROTTLE GRIP**

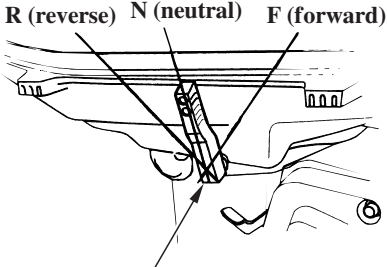

**R (reverse) N (neutral) F (forward)**

**GEARSHIFT LEVER**

To shift gears, turn the throttle grip to the SLOW position; then move the gearshift lever to select the F (forward), N (neutral), or R (reverse) gears.

The engine can be started with the gearshift lever in the N (neutral) position only.

The throttle grip can be turned to the FAST position only when the gearshift lever is in the F (forward) position.

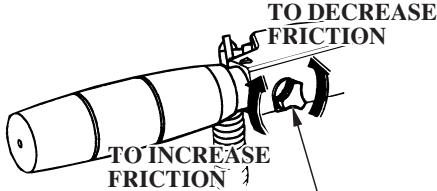

**THROTTLE FRICTION KNOB**

Use the throttle friction knob to help hold a constant throttle setting while cruising.

Turn the knob clockwise to increase throttle grip friction for holding a constant speed.

Turn the knob counterclockwise to decrease friction for easy grip rotation.

# OPERATION

---

## STEERING

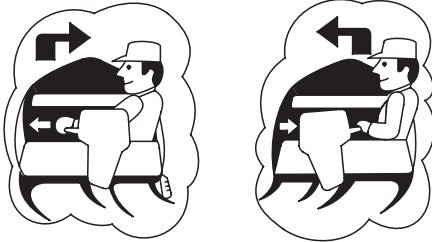

Steer by moving the tiller handle opposite the direction you want the boat to turn.

### STEERING FRICTION BOLT

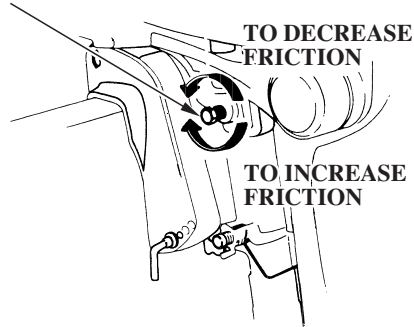

Use the steering friction bolt to help hold a steady course while cruising.

Turn the bolt clockwise to increase steering friction for holding a steady course.

Turn the bolt counterclockwise to decrease friction for easy turning.

**CRUISING**

**Engine Speed**

For best fuel economy, limit the throttle opening to 80%. Use the throttle friction control (p. 33 ) to help you hold a steady speed.

For rough water conditions or large waves, slow down to prevent the propeller from rising out of the water.

**Transom Angle**

Install the outboard motor at the best transom angle for stable cruising and maximum power.

Transom angle too large: Incorrect causes boat to “squat.”

Transom angle too small: Incorrect causes boat to “bow steer.”

It is necessary to adjust the transom angle of the outboard motor to compensate for changes in boat load, weight distribution, water conditions, or propeller selection.

Under normal running conditions, the boat will perform best when the antiventilation plate is level with the water surface.

When cruising into a high wind, adjust the outboard motor down slightly to level the boat and improve stability. With a tail wind, adjust the outboard motor up slightly (p. 25 ).

**NOTICE**

*Excessive transom angle during operation can cause propeller ventilation, overheating, and water pump damage. This type of damage is not covered by the Distributor’s Limited Warranty (p. 83 ).*

**Transom Angle (Cruising)**

**MOTOR ANGLE  
ADJUSTED TOO  
LOW**

**MOTOR ANGLE  
ADJUSTED TOO  
HIGH**

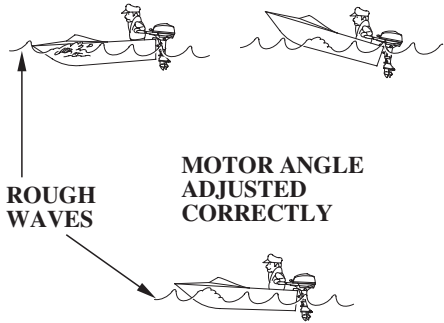

**CORRECT  
GIVES MAXIMUM PERFORMANCE**

## OPERATION

---

### SHALLOW WATER OPERATION

When operating in shallow water, tilt the outboard motor, using the tilt lever, so the propeller and gear case won't hit the bottom.

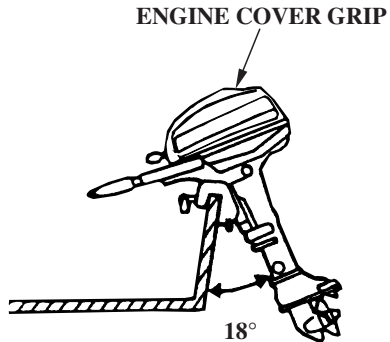

To tilt the outboard motor, raise the outboard motor to the 30° position by pulling on the engine cover grip.

#### NOTICE

*Do not use the tiller handle as a lever to raise the outboard motor. Applying excessive force to the tiller handle can damage it.*

While the outboard motor is tilted, proceed at a low speed, and do not operate the outboard motor in reverse. The outboard motor will rise suddenly if operated in reverse.

Monitor water flow from the cooling system indicator (p. 18 ) to be sure the outboard motor is not tilted so high that the water intakes are out of the water.

#### NOTICE

*An excessive tilt angle during operation can cause propeller ventilation, overheating, and water pump damage. This type of damage is not covered by the Distributor's Limited Warranty (p. 83 ).*

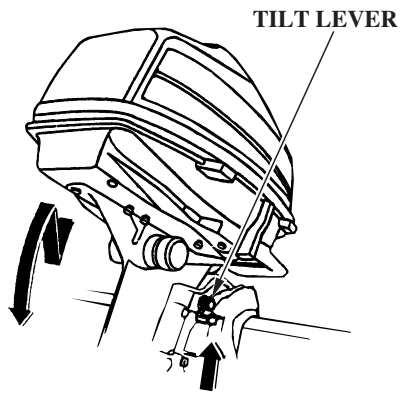

To return the outboard motor to the normal operating position, raise the outboard slightly by pulling on the engine cover grip, then pull the tilt lever to release the outboard, then slowly lower the outboard motor.

## MOORING, BEACHING, LAUNCHING

Before tilting up, leave the outboard motor in the running position for one minute after stopping the engine to drain the water from inside the engine.

### ENGINE COVER GRIP

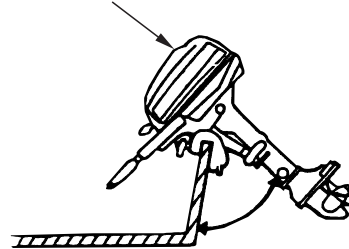

38°, 58° (when mooring)

To raise the outboard motor out of the water while the boat is moored, or for maximum clearance when beaching or launching, tilt the outboard motor to the 38° or 58° position.

Stop the engine before tilting the outboard motor. The 38° or 58° position is not an operating position.

Raise and lower the outboard motor as described on p. 36.

# SERVICING YOUR OUTBOARD MOTOR

## THE IMPORTANCE OF MAINTENANCE

Proper maintenance is essential for safe, economical, and trouble-free operation. It will also help reduce air pollution.

### **WARNING**

Improperly maintaining this outboard motor or failure to correct a problem before operation can cause a malfunction in which you could be seriously hurt or killed.

Always follow the inspection and maintenance recommendations and schedules in this Owner's Manual.

To help you properly care for your outboard motor, the following pages include a maintenance schedule, routine inspection procedures, and simple maintenance procedures using basic hand tools. Other service tasks that are more difficult or require special tools are best handled by professionals and are normally performed by a Honda technician or other qualified mechanic.

The maintenance schedule applies to normal operating conditions. If you operate your outboard motor under unusual conditions, consult an authorized Honda Marine dealer for recommendations applicable to your individual needs and use.

Remember that your authorized Honda Marine dealer knows your outboard motor best and is fully equipped to maintain and repair it.

To ensure the best quality and reliability, use only new, Honda Genuine parts or their equivalents for repair and replacement.

**Maintenance, replacement, or repair of the emission control devices and systems may be performed by any marine engine repair establishment or individual, using parts that are “certified” to EPA standards.**



## MAINTENANCE SAFETY

Some of the most important safety precautions follow. However, we cannot warn you of every conceivable hazard that can arise in performing maintenance. Only you can decide whether or not you should perform a given task.

### **WARNING**

Failure to properly follow maintenance instructions and precautions can cause you to be seriously hurt or killed.

Always follow the procedures and precautions in the Owner's Manual.

## Safety Precautions

- Make sure the engine is off before you begin any maintenance or repairs. This will eliminate several potential hazards:
  - **Carbon monoxide poisoning from engine exhaust.**  
Do not start or run the engine in a confined or partly enclosed area.
  - **Burns from hot parts.**  
Let the engine and exhaust system cool before touching.
  - **Injury from moving parts.**  
Do not run the engine unless instructed to do so.

- Read the instructions before you begin, and make sure you have the tools and skills required.
- To reduce the possibility of fire or explosion, be careful when working around gasoline. Use only a nonflammable solvent, not gasoline, to clean parts. Keep cigarettes, sparks, and flames away from all fuel-related parts.
- Wear gloves when handling the propeller to protect your hands from sharp edges.

# SERVICING YOUR OUTBOARD MOTOR

## TOOL KIT AND EMERGENCY STARTER ROPE

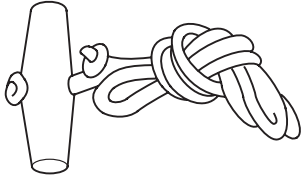

**EMERGENCY STARTER ROPE**

The following tools are supplied with the outboard motor for simple maintenance procedures and emergency repairs. An emergency starter rope is also supplied. Keep these items on the boat so that they will always be available if you need them.

If your tool kit needs replacement, it is not available as a kit and each item must be ordered individually.

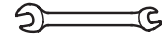

**10 × 12 mm WRENCH**



**FLAT SCREWDRIVER**



**PLIERS**

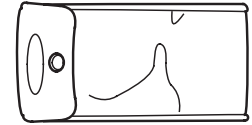

**TOOL BAG**



**PHILIPS SCREWDRIVER**

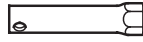

**SPARK PLUG  
WRENCH**



**SPARE EMERGENCY  
STOP SWITCH CLIP**



**8 mm WRENCH**

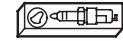

**SPARE SPARK PLUG**

**COTTER PINS**

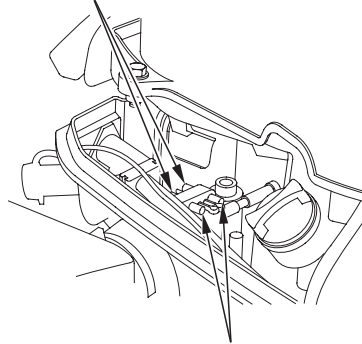

**SHEAR PINS**

**FLUSH KIT**

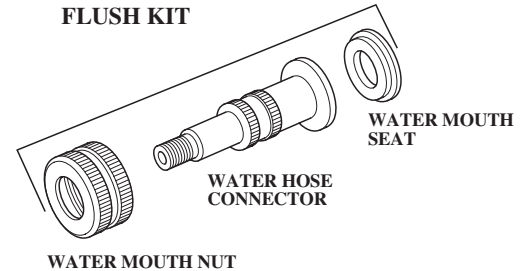

**WATER MOUTH  
SEAT**

**WATER HOSE  
CONNECTOR**

**WATER MOUTH NUT**

# SERVICING YOUR OUTBOARD MOTOR

## MAINTENANCE SCHEDULE

Follow the MAINTENANCE SCHEDULE table and service your outboard motor accordingly. Please note, a claim for warranty coverage will not be denied simply because the maintenance schedule for your outboard was not followed. However, any part(s) that fails specifically due to lack of maintenance, or improperly performed maintenance, would not be covered under the *Distributor's Limited Warranty*.

REGULAR SERVICE PERIOD (3) Perform at every indicated month or operating hour interval, whichever comes first.		Each use	After use	First month or 20 hrs.	Every 6 months or 100 hrs.	Every year or 200 hrs.
ITEM						
Engine oil	Check level	<input type="radio"/>				
	Change			<input type="radio"/>	<input type="radio"/>	
Gear case oil	Change			<input type="radio"/>	<input type="radio"/>	
Starter rope	Check				<input type="radio"/>	
Carburetor linkage	Check-adjust			<input type="radio"/> (2)	<input type="radio"/> (2)	
Valve clearance	Check-adjust					<input type="radio"/> (2)
Spark plug	Check-adjust				<input type="radio"/>	
	Replace					<input type="radio"/>
Propeller and cotter pin	Check	<input type="radio"/>				
Anode	Check	<input type="radio"/>				
Idling speed	Check-adjust			<input type="radio"/> (2)	<input type="radio"/> (2)	
Lubrication	Grease			<input type="radio"/> (1)	<input type="radio"/> (1)	

- (1) Lubricate more frequently when used in salt water.
- (2) These items should be serviced by an authorized Honda Marine dealer, unless you have the proper tools and are mechanically proficient. Refer to the Honda shop manual for service procedures.
- (3) For professional commercial use, log hours of operation to determine proper maintenance intervals.

# SERVICING YOUR OUTBOARD MOTOR

REGULAR SERVICE PERIOD (3) Perform at every indicated month or operating hour interval, whichever comes first.		Each use	After use	First month or 20 hrs.	Every 6 months or 100 hrs.	Every year or 200 hrs.
ITEM						
Fuel tank and tank filter	Clean					○
Thermostat	Check					○ (2)
Fuel filter	Check				○	
	Replace					○
Fuel line	Check	○				
	Replace		Every 2 years (If necessary) (2)			
Bolts and nuts	Check-tightness			○ (2)	○ (2)	
Crankcase breather tube	Check					○ (2)
Cooling water passages	Clean		○ (4)			
Water pump	Check					○ (2)
Emergency stop switch	Check	○				

- (1) Lubricate more frequently when used in salt water.
- (2) These items should be serviced by an authorized Honda Marine dealer, unless you have the proper tools and are mechanically proficient. Refer to the Honda shop manual for service procedures.
- (3) For professional commercial use, log hours of operation to determine proper maintenance intervals.
- (4) When operating in salt water, turbid or muddy water, the engine should be flushed with clean water after each use.

# SERVICING YOUR OUTBOARD MOTOR

## ENGINE COVER REMOVAL AND INSTALLATION

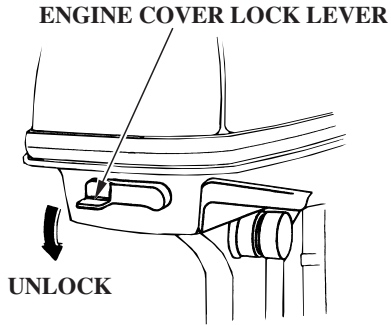

The engine cover lock lever fastens the engine cover to the outboard motor.

To remove the engine cover, turn the lock lever to the unlocked position, then lift the engine cover off the outboard motor.

To install the engine cover, place the cover on the outboard motor, then turn the lock lever to the locked position.

## Engine Oil Level Check

Check the engine oil level with the engine stopped and the outboard motor in the vertical position.

1. Unlock and remove the engine cover.
2. Remove the oil filler cap/dipstick and wipe it clean.

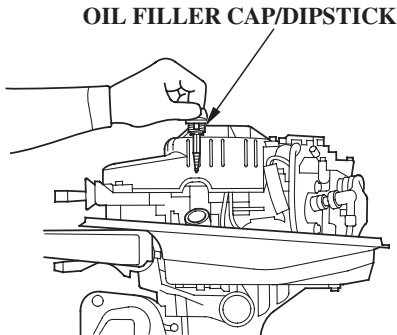

3. Insert the dipstick without screwing it in, then remove it and check the oil level shown on the dipstick.

## OIL FILLER CAP/DIPSTICK

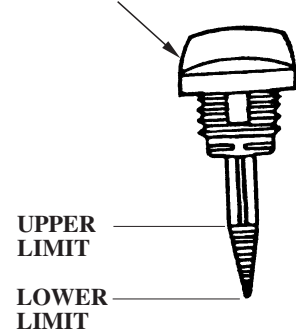

4. If the oil level is low, add oil to reach the upper limit mark shown on the dipstick. Use the oil recommended on p. 45.

### NOTICE

*Running the engine with a low oil level can cause engine damage.*

5. Install the oil filler cap/dipstick and tighten it securely.
6. Install and lock the engine cover.

# SERVICING YOUR OUTBOARD MOTOR

---

## Engine Oil Change

An engine oil evacuation device may be used to remove the engine oil.

Drain the used oil into a suitable container while the engine is warm. Warm oil drains quickly and completely.

1. Unlock and remove the engine cover (p. 43 ).

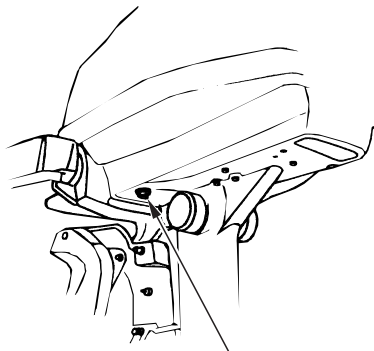

**DRAIN BOLT**

2. Remove the oil filler cap, and remove the engine oil drain plug and washer.
3. Allow the used oil to drain completely, then reinstall the engine oil drain plug and a new washer, and tighten it securely.

### NOTICE

*Improper disposal of engine oil can be harmful to the environment. If you change your own oil, please dispose of the used oil properly. Put it in a sealed container, and take it to a recycling center. Do not discard it in a trash bin, dump it on the ground, or pour it down a drain.*

4. With the outboard motor in a vertical position, fill to the upper limit mark on the dipstick (p. 43 ) with the recommended oil.
5. Install the oil filler cap and tighten it securely.
6. Install and lock the engine cover.

# SERVICING YOUR OUTBOARD MOTOR

## Engine Oil Recommendations

Oil is a major factor affecting performance and service life. Use 4-stroke detergent oil.

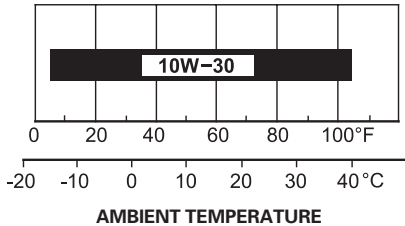

Honda 10W-30 FC-W™ outboard motor oil is recommended for general use.

If Honda 10W-30 FC-W oil is not available, Honda recommends that you use API service category SG, SH or SJ oil. The SAE oil viscosity and service category are in the API label on the oil container.

## Gear Case Oil Level Check

Check the gear case oil level with the engine stopped and the outboard motor in the vertical position.

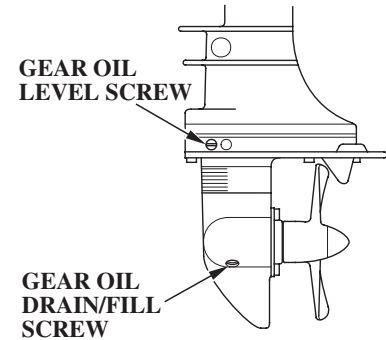

Remove the oil level screw and see whether oil flows from the oil level hole.

If oil flows from the oil level hole, the oil level is OK. Reinstall the screw and tighten it securely.

**OIL LEVEL SCREW TORQUE:**  
4.8 lbf·ft (6.5 N·m , 0.66 kgf·m)

## SERVICING YOUR OUTBOARD MOTOR

---

If no oil flows from the oil level hole, add the recommended oil (p. 47) following the procedure described in Gear Case Oil Change.

### Gear Case Oil Change

Change the gear case oil with the engine stopped and the outboard motor in the vertical position.

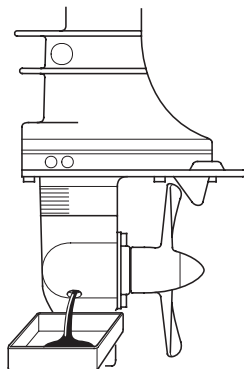

1. Place a suitable container below the oil drain hole to catch the used oil, then remove the oil level screw and oil drain/fill screw.

2. Allow the used oil to drain completely, then install an oil pump adapter in the oil drain hole.

If water or contaminated (milky-colored) oil flows out the drain hole when the screw is removed, have the outboard motor checked by an authorized Honda Marine dealer.



## SERVICING YOUR OUTBOARD MOTOR

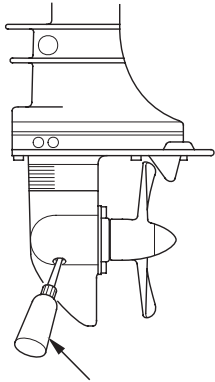

**GEAR OIL BOTTLE**

3. Add oil through the oil drain hole until it flows out the oil level hole, then install the oil level screw. Remove the pump adapter and install the oil drain/fill screw.

**GEAR OIL CAPACITY:  
0.11 US qt (0.10 L)**

Outboard motor SAE 90 hypoid  
gear oil API Service category  
(GL-4)

**OIL LEVEL SCREW TORQUE:  
4.8 lbf·ft (6.5 N·m, 0.66 kgf·m)**

Avoid losing more than 1 fl oz (30 cm<sup>3</sup>) while reinstalling the drain/fill screw.

**OIL DRAIN SCREW TORQUE:  
4.8 lbf·ft (6.5 N·m, 0.66 kgf·m)**

# SERVICING YOUR OUTBOARD MOTOR

## Lubrication Points

Apply Honda Marine waterproof grease to the parts shown below:

Lubrication interval:

20 operating hours or one month after the date of purchase or the initial use, then every 100 hours or 6 months (refer to the maintenance schedule on page 41).

### NOTICE

*To prevent corrosion, apply anticorrosion oil to pivot surfaces where grease cannot penetrate.*

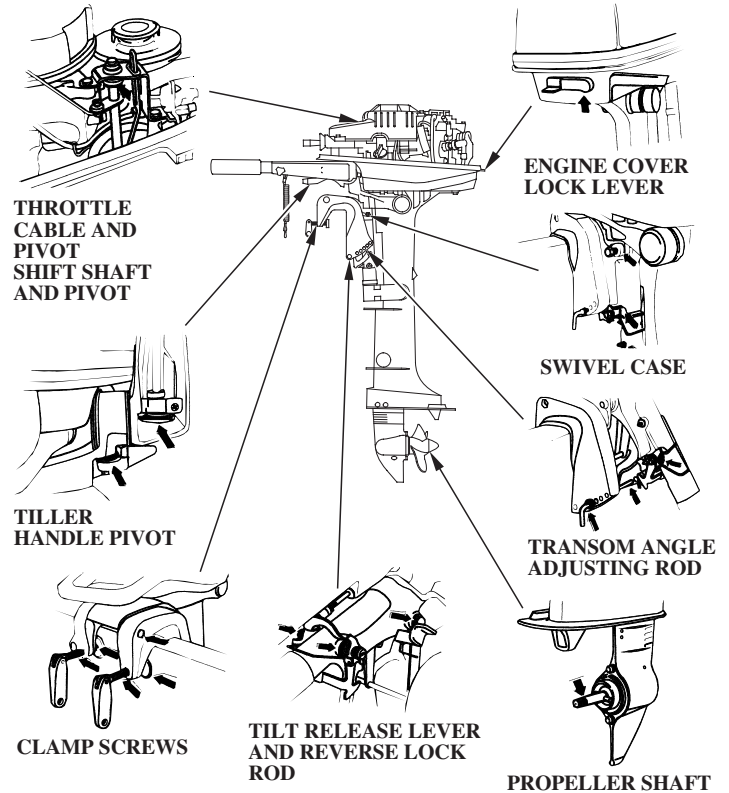

Apply Honda Marine Corrosion Inhibitor (or equivalent) to all areas under the engine cover and any exposed metal surfaces.

# SERVICING YOUR OUTBOARD MOTOR

## Spark Plug Service

RECOMMENDED SPARK PLUGS:  
BPR5ES (NGK)  
W16EPR-U (DENSO)

### NOTICE

*Incorrect spark plug can cause engine damage.*

1. Unlock and remove the engine cover (p. 43).
2. Disconnect the spark plug cap from the spark plug.
3. Remove the spark plug with a spark plug wrench and screwdriver supplied in the tool kit.

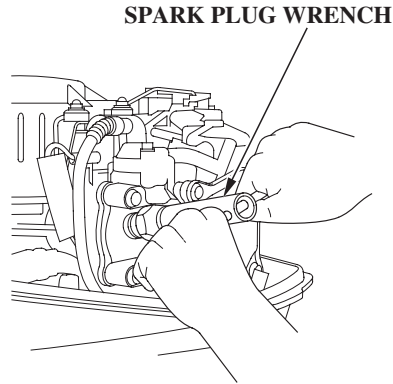

4. Inspect the spark plug. Replace it if the electrode is worn, or if the insulator is cracked or chipped.

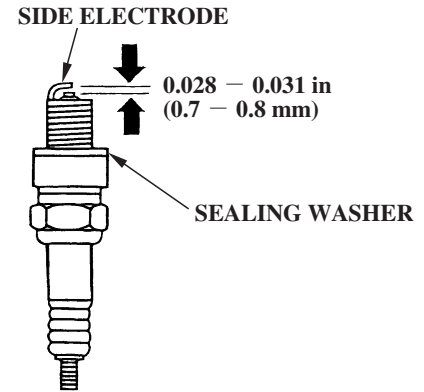

5. Measure the spark plug electrode gap with a wire-type feeler gauge. Correct the gap, if necessary, by carefully bending the side electrode.

The gap should be:  
0.028 - 0.031 in  
(0.7 - 0.8 mm)

# SERVICING YOUR OUTBOARD MOTOR

6. Install the spark plug carefully, by hand, to avoid cross-threading.
7. After the spark plug seats, tighten with a spark plug wrench supplied in the tool kit to compress the sealing washer.

If reinstalling the used spark plug, tighten 1/8 – 1/4 turn after the spark plug seats.

If installing new spark plug, tighten 1/2 turn after the spark plug seats.

## NOTICE

*A loose spark plug can overheat and damage the engine. Overtightening the spark plug can damage the threads in the cylinder head.*

8. Attach the spark plug cap.
9. Install and lock the engine cover.

## REFUELING

### Portable Fuel Tank

**FUEL TANK CAPACITY:**  
**3.2 US gal (12 L)**

Check the fuel gauge and refill the tank when necessary. Remove the fuel tank from the boat for refueling.

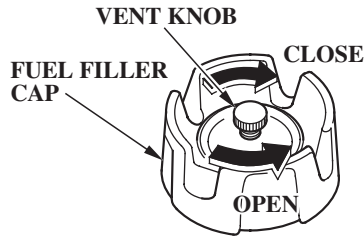

To refuel, turn the vent knob counterclockwise to the OPEN position, and unscrew the fuel filler cap.

Refuel in a well-ventilated area. Fill the tank to the SAFE FILL LEVEL line.

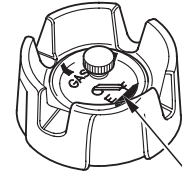

**FUEL GAUGE**

**SAFE FILL LEVEL**

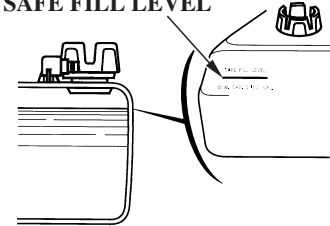

After refueling, install the fuel filler cap and tighten it securely. Turn the vent knob clockwise to the CLOSED position, and return the fuel tank to the boat.

## NOTICE

*Fuel can damage paint and plastic. Be careful not to spill fuel when filling your fuel tank. Damage caused by spilled fuel is not covered under warranty.*

# SERVICING YOUR OUTBOARD MOTOR

## **⚠ WARNING**

Gasoline is highly flammable and explosive.

You can be burned or seriously injured when handling fuel.

- Stop the engine and keep heat, sparks, and flame away.
- Handle fuel only outdoors.
- Wipe up spills immediately.

Never refill the fuel tank inside a building where gasoline fumes may reach flames or sparks. Keep gasoline away from appliance pilot lights, barbecues, electric appliances, power tools, etc.

Spilled fuel is not only a fire hazard, it causes environmental damage. Wipe up spills immediately.

## **FUEL RECOMMENDATIONS**

**Use unleaded gasoline with a pump octane rating of 86 or higher.**

Your outboard motor is certified to operate on unleaded gasoline. Unleaded gasoline produces fewer engine and spark plug deposits and extends exhaust system life.

Never use stale or contaminated gasoline or an oil/gasoline mixture. Avoid getting dirt or water in the fuel tank.

You may use unleaded gasoline containing no more than 10% ethanol (E10) or 5% methanol by volume. In addition, methanol must contain cosolvents and corrosion inhibitors.

Use of fuels with content of ethanol or methanol greater than shown above may cause starting and/or performance problems. It may also damage metal, rubber, and plastic parts of the fuel system.

Engine damage or performance problems that result from using a fuel with percentages of ethanol or methanol greater than shown above are not covered under warranty.

If your outboard will be used on an infrequent or intermittent basis, please refer to the fuel section of the STORAGE chapter (p. 60 ) for additional information regarding fuel deterioration.

# SERVICING YOUR OUTBOARD MOTOR

## Fuel Filter Inspection and Replacement

The fuel filter is located under the engine cover, on the right side of the engine.

Water or sediment accumulation in the filter can cause loss of power or hard starting. To prevent engine malfunction, inspect the filter and replace when necessary.

### **⚠ WARNING**

Gasoline is highly flammable and explosive.

You can be burned or seriously injured when handling fuel.

- Stop the engine and keep heat, sparks, and flame away.
- Handle fuel only outdoors.
- Wipe up spills immediately.

ENGINE COVER LOCK LEVER

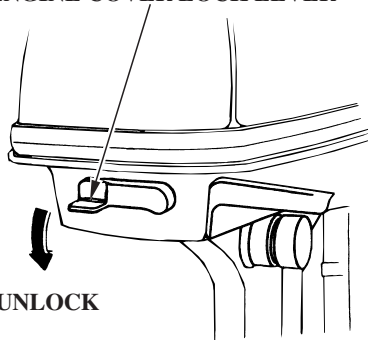

UNLOCK

1. Unlock and remove the engine cover for access to the fuel pump filter.
2. Inspect the filter for water and/or sediment accumulation.

If the filter is OK, reinstall it. If water and/or sediment are present, replace the filter as described in the following steps. Always replace the filter at the scheduled replacement interval (p. 42).

3. Disconnect the fuel hose connector from the outboard motor, and place commercially available hose clips on the fuel hoses on each side of the filter to prevent fuel leakage when the fuel hoses are disconnected.

## SERVICING YOUR OUTBOARD MOTOR

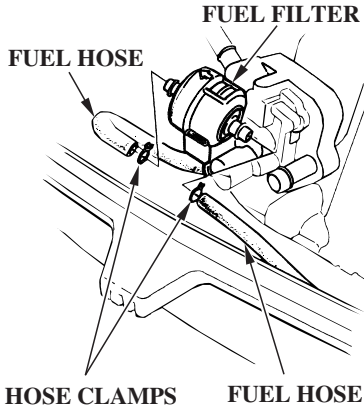

4. Remove the fuel hoses from the used filter, and discard the filter.

To ease hose removal, release the hose clamps by squeezing the clamp ends together with pliers while pulling off the hoses.

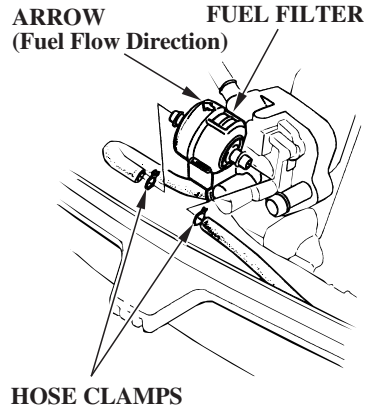

5. Install the new filter on the fuel hoses, with the fuel flow arrow pointing toward the fuel pump as shown. Fuel flow will be impeded if the filter is installed backward.
6. Connect the fuel hoses to the fuel filter securely with the hose clamps. Remove the fuel hose clips used to close the fuel hoses.

7. Securely connect the fuel hose connector to the outboard motor (refer to page 26).
8. Prime the engine using the priming bulb (p. 27). Check for fuel leaks. Repair any fuel leaks if necessary.
9. Install and lock the engine cover.

If loss of power or hard starting are found to be caused by excessive water or sediment accumulation in the fuel filter, inspect the fuel tank.

Clean the fuel tank and tank filter if necessary. It may be necessary to drain the fuel tank completely and refill with fresh gasoline.

# SERVICING YOUR OUTBOARD MOTOR

---

## Portable Fuel Tank and Tank Filter Cleaning

### **⚠ WARNING**

Gasoline is highly flammable and explosive.

You can be burned or seriously injured when handling fuel.

- Stop the engine and keep heat, sparks, and flame away.
- Handle fuel only outdoors.
- Wipe up spills immediately.

### *Fuel Tank*

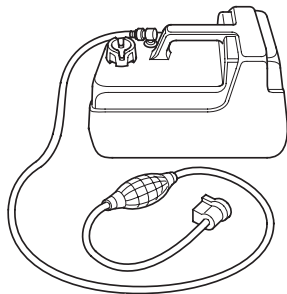

**FUEL HOSE**

Empty the portable fuel tank into an approved gasoline container. Use a funnel to avoid spilling fuel. Rinse the fuel tank with nonflammable solvent to remove any accumulated sediment.



# SERVICING YOUR OUTBOARD MOTOR

## Fuel Tank Filter

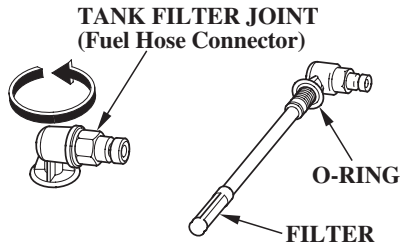

1. Unscrew the fuel hose connector by turning it counterclockwise; then remove the fuel hose connector and fuel tank filter from the tank.
2. Clean the filter in nonflammable solvent. Inspect the fuel tank filter and the connector O-ring. Replace them if damaged.
3. Reinstall the filter and hose connector in the fuel tank. Tighten the hose connector securely.

## Recoil Starter Rope Inspection

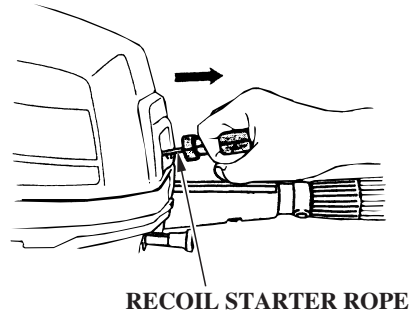

Inspect the recoil starter rope, and replace it if it becomes frayed.

Always keep the emergency starter rope on the boat in case the recoil starter rope fails.

## Anode Replacement

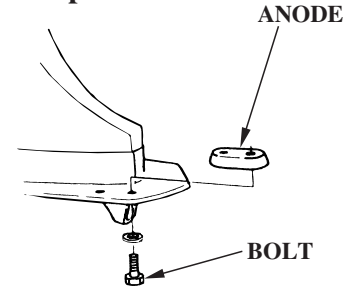

The anode is located on the antiventilation plate. It is made of a sacrificial material that helps to protect the outboard motor from corrosion.

Replace the anode when it has been reduced to about half its original size, or if it is crumbling.

### NOTICE

*Painting or coating the anodes will defeat their purpose and will lead to rust and corrosion damage to the outboard motor. The anodes must be exposed to the water in order to protect the outboard motor.*

# SERVICING YOUR OUTBOARD MOTOR

## Propeller and Shear Pin Replacement

A shear pin is used to protect the propeller and drive mechanism from damage when the propeller strikes an obstruction.

Before replacing the propeller or the shear pin, remove the emergency stop switch clip from the emergency stop switch to prevent any possibility of the engine being started while you are working with the propeller.

The propeller blades may have sharp edges, so wear heavy gloves to protect your hands.

Operating the outboard motor at higher altitudes will reduce available power. This may require decreasing the propeller pitch to maintain correct engine RPM.

### *Removal*

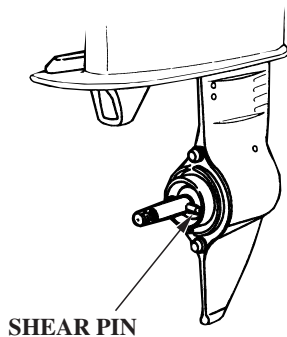
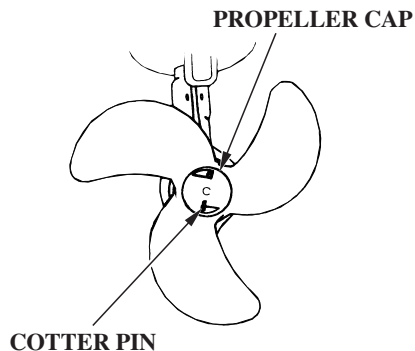

1. Remove the cotter pin, the propeller cap, and the propeller.
2. Remove the broken shear pin and replace it with a new one.

### *Installation*



1. Install the shear pin and the propeller, then install the propeller cap finger tight.
  2. Be sure to replace the cotter pin with a new one.
- Use a Honda Genuine stainless steel cotter pin or equivalent cotter pin and bend the pin ends as shown.

Spare shear pins and cotter pins are provided in the engine compartment (p. 40).

# STORAGE

## STORAGE PREPARATION

Proper storage preparation is essential for keeping your outboard motor trouble-free and looking good. The following steps will help to keep rust and corrosion from impairing your outboard motor's function and appearance, and will make the engine easier to start when you use the outboard motor again.

## Cleaning and Flushing

Thoroughly clean and flush the outboard motor with fresh water after operation in dirty water or salt water.

### *Cleaning*

Wash the outside of the outboard motor with clean, fresh water to remove mud, salt, seaweed, etc.

Disengage the emergency stop switch clip from the emergency stop switch, and pull the recoil starter rope several times to expel any water remaining in

the water pump.

Touch up any damaged paint, and coat areas that may rust with Honda Corrosion Inhibitor, or equivalent. Lubricate controls with a silicone spray lubricant.

### *Flushing With the Honda Water Hose Connector*

1. Tilt down the outboard motor.
2. Remove the flush screw from the WASH screw hole and install the water hose connector.
3. Attach a hose from a fresh water faucet to the water hose connector of the flush kit.
4. Remove the propeller (P. 56).
5. Turn on the fresh water supply to hose.
6. Start the engine and run in N (neutral) for 10 minutes.

### WATER HOSE CONNECTOR

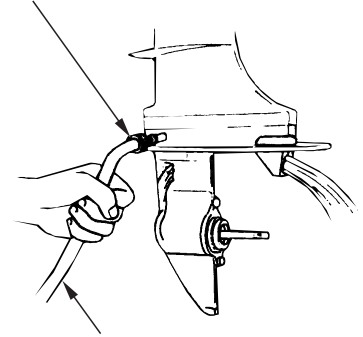

### WATER HOSE

7. After flushing, stop the engine, remove the hose connector, and leave the outboard motor in the running position for one minute to drain the water from inside the engine.
8. Reinstall the flush screw and the propeller (p. 57).
9. Tilt up the outboard motor and move the tilt lever to the TILT position.

## *Flushing Without the Honda Water Hose Connector*

It is necessary to run the engine during the flushing procedure. For safety, remove the propeller from the outboard motor (p. 56).

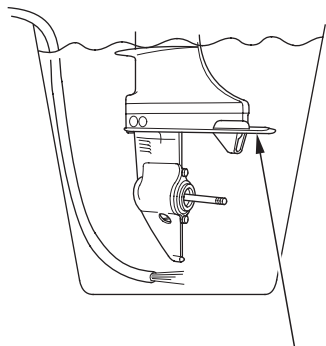

**ANTIVENTILATION PLATE**

1. Tilt down the outboard motor.
2. Place a container under the outboard motor, and fill it with clean, fresh water. The water level must be at least 2 inches (5 cm) above the antiventilation plate.

### **NOTICE**

*Running the engine without good water circulation can cause overheating and water pump damage.*

Damage caused by running the outboard motor without sufficient cooling water is not covered by the *Distributor's Limited Warranty* (p. 83 ).

3. Start the engine and run in the N (neutral) position at low speed for at least 10 minutes.
4. After flushing, stop the engine, and leave the outboard motor in the running position for one minute to drain the water from inside the engine.
5. Reinstall the propeller (p. 57).
6. Tilt up the outboard motor and move the tilt lever to the TILT position.

## STORAGE

---

### Fuel

#### NOTICE

*Depending on the region where you operate your outboard, fuel formulations may deteriorate and oxidize rapidly. Fuel deterioration and oxidation can occur in as little as 15 days and may cause damage to the carburetor and fuel system. Please check with your servicing dealer for local storage recommendations.*

Gasoline will oxidize and deteriorate in storage. Old gasoline will cause hard starting, and it leaves gum deposits that clog the fuel system. If the gasoline in your fuel tank and carburetor deteriorates during storage, you may need to have the carburetor and other fuel system components serviced or replaced.

The length of time that gasoline can be left in your fuel tank and carburetor without causing functional problems will vary with such factors as gasoline blend, your storage temperatures, and whether the fuel tank is partially or completely filled. The air in a partially filled fuel tank promotes fuel deterioration. Very warm storage temperatures accelerate fuel deterioration. Fuel deterioration problems may occur in less than 30 days, if the gasoline was not fresh when you filled the fuel tank.

You can extend fuel storage life by adding a gasoline stabilizer that is formulated for that purpose, or you can avoid fuel deterioration problems by draining all the fuel from the fuel tank and carburetor.

The *Distributor's Limited Warranty* (p. 83 ) does not cover fuel system damage or engine performance problems resulting from neglected storage preparation.

### ***Adding a Fuel Stabilizer***

When adding a fuel stabilizer, fill the fuel tank with fresh gasoline. If only partially filled, air in the tank will promote fuel deterioration during storage. If you keep an additional container of gasoline for refueling, be sure that it contains only fresh gasoline.

1. Add fuel stabilizer following the manufacturer's instructions.
2. After adding a fuel stabilizer, run the engine in water for 10 minutes to be sure that the treated gasoline has replaced the untreated gasoline in the carburetor.
3. Turn the engine OFF.

## *Draining the Fuel System*

You can avoid fuel deterioration problems by draining the fuel tank and carburetor.

1. Disconnect the fuel hose from the outboard motor.
2. Disconnect the drain tube from the air guide, then connect it to the carburetor drain port as shown.

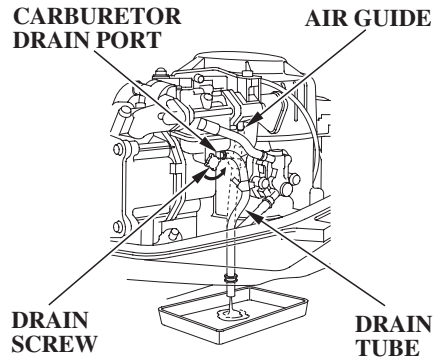

3. With the outboard motor in a vertical position, place an approved gasoline container below the fuel drain outlet, and use a funnel to avoid spilling fuel. Loosen the drain screw to drain fuel from the carburetor.

## **⚠ WARNING**

Gasoline is highly flammable and explosive.

You can be burned or seriously injured when handling fuel.

- Stop the engine and keep heat, sparks, and flame away.
- Handle fuel only outdoors.
- Wipe up spills immediately.

4. After the fuel has drained from the carburetor, tighten the drain screw securely.
5. Reconnect the drain tube to the air guide.
6. Drain the portable fuel tank into an approved gasoline container, or if you need to store fuel in the fuel tank, you can extend fuel storage life by filling the fuel tank with fresh gasoline and adding a fuel stabilizer that is formulated for that purpose. Firmly close the fuel filler cap vent knob.

Store the portable fuel tank in a cool place.

# STORAGE

## Engine Oil

1. Change the engine oil (p. 44).
2. Remove the spark plug (p. 49 ), and remove the emergency stop switch clip from the emergency stop switch.
3. Pour 1—2 teaspoons (5 — 10 cm<sup>3</sup>) of clean engine oil into the cylinder.
4. Pull the starter grip several times to distribute the oil in the cylinder.
5. Reinstall the spark plug (p. 50 ).

## STORAGE PRECAUTIONS

Select a well-ventilated storage area. If possible, avoid storage areas with high humidity.

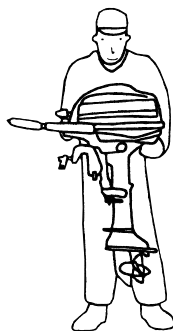
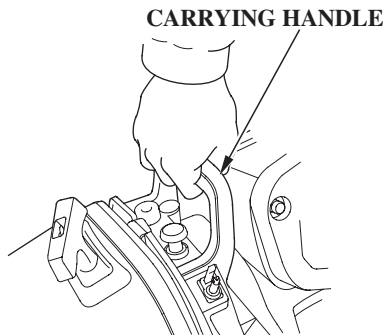

To carry the outboard motor, hold it by the carrying handle, or hold by the carrying handle and the lug beneath the engine cover lock lever, as shown.

### NOTICE

*Lifting the outboard motor by the engine cover, or using the installed outboard motor as a handle or lever to move the boat, can damage the outboard motor.*

If your portable fuel tank contains gasoline, store it away from any appliance that operates with a flame, such as a furnace, water heater, or clothes dryer. Also avoid any area with a spark-producing electric motor, or where power tools are operated.



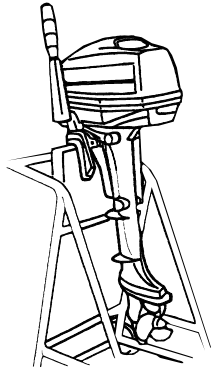

Store the outboard motor either vertically or horizontally with the tiller handle side up.

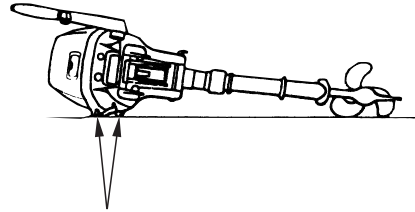

CASE PROTECTORS

If storing horizontally, be sure to fold the tiller handle, and rest the outboard motor on its case protectors. Be sure all water has drained from the outboard motor before placing it on its side, so no residual water can enter the engine exhaust port.

**NOTICE**

*Any other horizontal storage position may cause damage to the outboard motor or oil leakage.*

Cover the outboard motor to keep out dust. Do not use plastic sheet as a dust cover. A nonporous cover will trap moisture, promoting rust and corrosion.

### REMOVAL FROM STORAGE

Check your outboard motor as described in the *BEFORE OPERATION* chapter of this manual.

If the cylinder was coated with oil during storage preparation, the engine may smoke briefly at startup. This is normal.

# TRANSPORTING

## WITH OUTBOARD MOTOR INSTALLED ON BOAT

When trailering a boat with the outboard motor attached, leave the engine in the normal running position, if possible, and tighten the steering friction bolt securely (p. 34).

If there is insufficient road clearance in the normal running position, then tilt the outboard motor and use a motor support bar, or remove the outboard motor from the boat. Refer to the manufacturer's instructions for using a motor support bar.

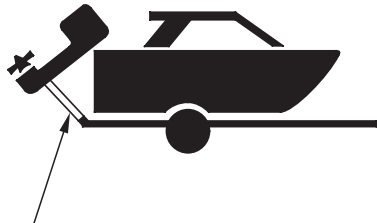

**MOTOR SUPPORT BAR**  
(commercially available)

## WITH OUTBOARD MOTOR REMOVED FROM BOAT

Remove the outboard motor from the boat and secure the outboard motor in either the vertical or horizontal position shown on p. 63.

**CARRYING HANDLE**

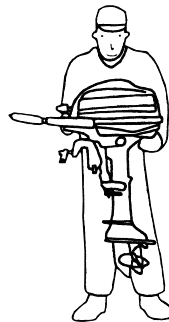
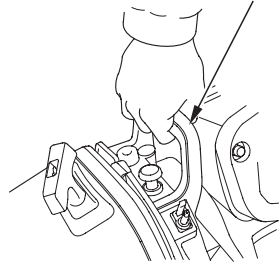

To carry, hold the outboard motor by the carrying handle, or hold by the carrying handle and the lug beneath the engine cover lock latch, as shown.

### **NOTICE**

*Lifting the outboard motor by the engine cover, or using the installed outboard motor as a handle or lever to move the boat, can damage the outboard motor.*

## TAKING CARE OF UNEXPECTED PROBLEMS

ENGINE WILL NOT START	Possible Cause	Correction
1. Check emergency stop switch clip.	Clip not inserted in emergency stop switch.	Insert clip in emergency stop switch.
2. Check control positions.	Gearshift lever not in neutral position.	Shift to neutral (p. 28 ).
	Choke OFF.	Pull choke knob to ON position, unless engine is warm (p. 28 ).
	Throttle grip not in START position.	Turn throttle grip to START position (p. 28 ).

## TAKING CARE OF UNEXPECTED PROBLEMS

---

ENGINE WILL NOT START (continued)	Possible Cause	Correction
3. Check fuel.	Out of fuel.	Refuel (p. 50).
	Fuel vent closed (portable fuel tank).	Open fuel filler cap vent knob (p. 26).
	Fuel hose not primed.	Squeeze priming bulb (p. 27).
	Fuel filter or fuel tank filter restricted.	Replace restricted filters (p. 52 or 55).
	Bad fuel; boat stored without treating or draining gasoline, or refueled with bad gasoline.	Drain fuel tank and carburetor (p. 61). Refill with fresh gasoline (p. 50).
4. Remove and inspect spark plug.	Spark plug faulty, fouled, or improperly gapped.	Gap or replace spark plug (p. 49).
	Spark plug wet with fuel (flooded engine).	Dry and reinstall spark plug. Start engine with choke and throttle open.
5. Take outboard motor to an authorized Honda Marine dealer, or refer to the shop manual.	Carburetor malfunction, fuel pump failure, ignition malfunction, stuck valves, etc.	Replace or repair faulty components as necessary.

## TAKING CARE OF UNEXPECTED PROBLEMS

HARD STARTING OR STALLS AFTER STARTING	Possible Cause	Correction
1. Check control positions.	Choke OFF.	Pull choke knob to ON position, unless engine is warm (p. 28).
	Throttle grip not in START position.	Turn throttle grip to START position (p. 28).
2. Check fuel.	Fuel vent closed (portable fuel tank).	Open fuel filler cap vent knob (p. 26).
	Fuel hose not primed.	Squeeze priming bulb (p. 27).
	Fuel filter or fuel tank filter restricted.	Replace restricted filters (p. 52 or 55).
	Bad fuel; boat stored without treating or draining gasoline, or refueled with bad fuel.	Drain fuel tank and carburetor (p. 61). Refill with fresh gasoline (p. 50).

## TAKING CARE OF UNEXPECTED PROBLEMS

---

HARD STARTING OR STALLS AFTER STARTING (continued)	Possible Cause	Correction
3. Remove and inspect spark plug.	Spark plug faulty, fouled, or improperly gapped.	Gap or replace spark plug (p. 49).
4. Take outboard motor to an authorized Honda Marine dealer, or refer to the shop manual.	Carburetor malfunction, fuel pump failure, ignition malfunction, etc.	Replace or repair faulty components as necessary.

ENGINE OVERHEATS	Possible Cause	Correction
1. Check water intakes.	Water intakes clogged.	Clean water intakes.
2. Take outboard motor to an authorized Honda Marine dealer, or refer to the shop manual.	Faulty thermostat or water pump.	Replace or repair faulty components as necessary.

## TAKING CARE OF UNEXPECTED PROBLEMS

---

ENGINE WILL NOT DRIVE THE PROPELLER	Possible Cause	Correction
1. Check shear pin.	Broken shear pin.	Replace shear pin (p. 56).
2. Take outboard motor to an authorized Honda Marine dealer, or refer to the shop manual.	Damaged gearshift mechanism.	Replace or repair faulty components as necessary.

## TAKING CARE OF UNEXPECTED PROBLEMS

---

### OIL PRESSURE INDICATOR GOES OFF AND ENGINE SPEED IS LIMITED

OIL PRESSURE INDICATOR

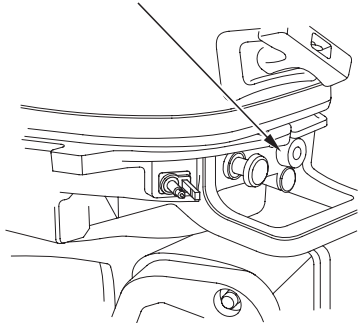

If oil pressure becomes low, the green indicator will go off. If you are at cruising speed, engine speed will decrease gradually.

Low oil pressure may be the result of a low engine oil level, or there may be a problem with the engine lubrication system.

If the throttle is closed suddenly after full throttle operation, engine speed may drop below the specified idle rpm, and that could activate the engine protection system momentarily.

If low oil pressure activates the engine protection system, stop the engine, check the engine oil level (p. 43), and add oil if needed.

With the engine oil at the recommended level, restart the engine. If the lubrication system is OK, the green indicator should come on within 30 seconds, and the engine will respond normally to throttle grip operation.

If the engine protection system remains activated after 30 seconds, return to the nearest boat landing, and have the outboard motor inspected by an authorized Honda Marine dealer.



## TAKING CARE OF UNEXPECTED PROBLEMS

### SUBMERGED MOTOR

A submerged outboard motor must be serviced immediately after it is recovered from the water in order to minimize corrosion.

If there is a Honda Marine dealership nearby, take the motor to the dealer immediately. If you are far from a dealer, proceed as follows:

1. Remove the engine cover, and rinse the outboard motor with fresh water to remove salt water, sand, mud, etc.
2. Drain the carburetor as described on p. 61 .

3. Change the engine oil as described on p. 44. If there was water in the engine crankcase, or if the used engine oil showed signs of water contamination, then a second engine oil change should be performed after running the engine for half an hour.

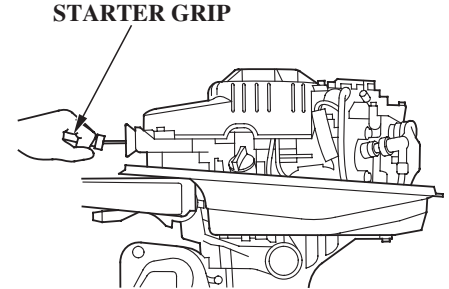

4. Remove the spark plug (p. 49 ), and remove the emergency stop switch clip from the emergency stop switch. Pull the starter grip, rotate the flywheel a few revolutions to completely expel any water from the cylinder.

If the engine was running when it submerged, there may be mechanical damage, such as a bent connecting rod. If the engine binds when cranked, do not attempt to run the engine until it has been repaired.

## TAKING CARE OF UNEXPECTED PROBLEMS

---

### NOTICE

*When cranking the engine with an open ignition circuit (spark plug removed from the ignition circuit), remove the emergency stop switch clip from the emergency stop switch to prevent possible damage to the ignition system.*

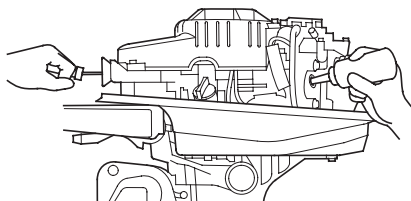

5. Pour a teaspoon of engine oil into the spark plug hole, then pull the starter grip several times to lubricate the inside of the cylinder.
6. Reinstall the spark plug, and put the emergency stop switch clip into the emergency stop switch.

7. Attempt to start the engine. Be sure the water level is at least 2 inches (5 cm) above the antivibration plate.

If the engine fails to start, remove the spark plug, clean and dry it, then reinstall the spark plug and attempt to start the engine again.

If the engine starts, and no mechanical damage is evident, continue to run the engine for a half hour or longer. Be sure the water level is at least 2 inches (5 cm) above the antivibration plate to avoid overheating and water pump damage.

8. As soon as possible, take the outboard motor to an authorized Honda Marine dealer for inspection and service.

# TECHNICAL AND CONSUMER INFORMATION

## TECHNICAL INFORMATION

### Serial Number Locations

Record the product identification number, the engine serial number, and the date of purchase in the space provided on this page. You will need these numbers when ordering parts, and when making technical or warranty inquiries (p. 81 ).

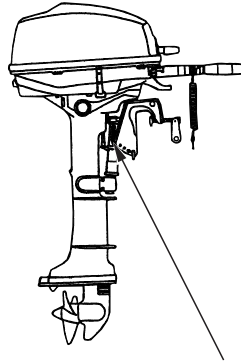

**PRODUCT IDENTIFICATION NUMBER**

The product identification number is stamped on the swivel case.

Product identification number:

---

Date of purchase:

---

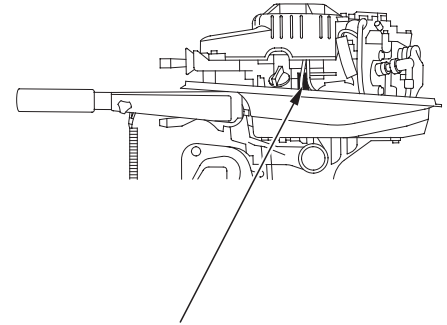

**ENGINE SERIAL NUMBER**

The engine serial number is stamped on the right side of the motor.

Engine serial number:

---

## TECHNICAL AND CONSUMER INFORMATION

---

### Carburetor Modification for High Altitude Operation

At altitudes above 2,000 ft (600 meters), the standard carburetor air-fuel mixture will be too rich. Performance will decrease, and fuel consumption will increase. A very rich mixture will also foul the spark plug and cause hard starting. Operation at an altitude that differs from that at which this engine was certified, for extended periods of time, may increase emissions.

High altitude operation can be improved by specific modifications to the carburetor. If you usually operate your outboard motor at 2,000 ft (600 meters) or above, consult with your authorized Honda Marine dealer.

Your dealer can determine the appropriate carburetor settings for the altitude at which you operate your outboard motor.

#### Settings:

- Standard setting is for sea level to 2,000 ft (600 meters).
- Mid-altitude setting is for 2,000 ft (600 meters) to 5,000 ft (1,500 meters).
- High-altitude setting is for 5,000 ft (1,500 meters) and above.

Even with carburetor modification, engine horsepower will decrease about 3.5% for each 1,000-foot (300-meter) increase in altitude. The effect of altitude on horsepower will be greater than this if no carburetor modification is made.

#### NOTICE

*When the carburetor has been modified for operation at one of the higher altitude ranges, the air-fuel mixture will be too lean for operation at a lower altitude. Operation at altitudes below the range for which the carburetor is set may cause the engine to overheat and result in serious engine damage. For use at lower altitudes, have an authorized Honda Marine dealer modify the carburetor for the correct altitude range.*

### **Emission Control System Information**

#### *Source of Emissions*

The combustion process produces carbon monoxide, oxides of nitrogen, and hydrocarbons. Control of hydrocarbons and oxides of nitrogen is very important because, under certain conditions, they react to form photochemical smog when subjected to sunlight. Carbon monoxide does not react in the same way, but it is toxic.

Honda utilizes appropriate air/fuel ratios and other emissions control systems to reduce the emissions of carbon monoxide, oxides of nitrogen, and hydrocarbons.

#### *The U.S. and California Clean Air Acts*

EPA and California regulations require all manufacturers to furnish written instructions describing the operation and maintenance of emission control systems.

The following instructions and procedures must be followed in order to keep the emissions from your Honda engine within the emission standards.

#### *Tampering and Altering*

Tampering with or altering the emission control system may increase emissions beyond the legal limit. Among those acts that constitute tampering are:

- Removal or alteration of any part of the intake, fuel, or exhaust systems.
- Alterations that would cause the engine to operate outside its design parameters.

## TECHNICAL AND CONSUMER INFORMATION

---

### *Problems That May Affect Emissions*

If you are aware of any of the following symptoms, have your engine inspected and repaired by your servicing dealer.

- Hard starting or stalling after starting.
- Rough idle.
- Misfiring or backfiring under load.
- Afterburning (backfiring).
- Black exhaust smoke or high fuel consumption.

### *Replacement Parts*

The emission control systems on your Honda engine were designed, built, and certified to conform with EPA and California emission regulations. We recommend the use of Honda Genuine parts whenever you have maintenance done. These original-design replacement parts are manufactured to the same standards as the original parts, so you can be confident of their performance. The use of replacement parts that are not of the original design and quality may impair the effectiveness of your emission control system.

A manufacturer of an aftermarket part assumes the responsibility that the part will not adversely affect emission performance. The manufacturer or rebuilder of the part must certify that use of the part will not result in a failure of the engine to comply with emission regulations.

### *Maintenance*

Follow the maintenance schedule on (p. 41 and 42 ). Remember that this schedule is based on the assumption that your machine will be used for its designed purpose. Sustained high-load operation, or use in unusual conditions, will require more frequent service.

# TECHNICAL AND CONSUMER INFORMATION

## Star Label US, Puerto Rico, and US Virgin Islands

A Star label was applied to this outboard motor in accordance with the requirements of the California Air Resources Board.

### *The Star Label means Cleaner Marine Engine*

This engine has been certified as a:



### The Symbol for Cleaner Marine Engines:

**Cleaner Air and Water** - for healthier lifestyle and environment.

**Better Fuel Economy** - burns up to 30 - 40 percent less gas and oil than conventional carbureted two-stroke engines, saving money and resources.

**Longer Emission Warranty** - protects consumer for worry-free operation.

## TECHNICAL AND CONSUMER INFORMATION

---



### **One Star Low Emission**

The one-star label identifies engines that meet the Air Resources Board's Personal Watercraft and Outboard marine engine 2001 exhaust emission standards. Engines meeting these standards have 75% lower emissions than conventional carbureted two-stroke engines. These engines are equivalent to the U.S. EPA's 2006 standards for marine engines.



### **Two Stars Very Low Emission**

The two-star label identifies engines that meet the Air Resources Board's Personal Watercraft and Outboard marine engine 2004 exhaust emission standards. Engines meeting these standards have 20% lower emissions than One Star-Low Emission engines.



### **Three Stars Ultra Low Emission**

The three-star label identifies engines that meet the Air Resources Board's Personal Watercraft and Outboard marine engine 2008 exhaust emission standards or the Sterndrive and Inboard marine engine 2003-2008 exhaust emission standards. Engines meeting these standards have 65% lower emissions than One Star-Low Emission engines.



### **Four Stars Super Ultra Low Emission**

The four-star label identifies engines that meet the Air Resources Board's Sterndrive and Inboard marine engine 2009 exhaust emission standards. Personal Watercraft and Outboard marine engines may also comply with these standards. Engines meeting these standards have 90% lower emissions than One Star-Low Emission engines.

Cleaner Watercraft - Get the Facts  
1-800-END-SMOG  
[www.arb.ca.gov](http://www.arb.ca.gov)



# TECHNICAL AND CONSUMER INFORMATION

## Specifications

MODEL	BF5A	
Description code	BADS	
Type	S	L
Overall length	20.7 in (525 mm)	
Overall width	13.8 in (350 mm)	
Overall height	39.6 in (1,005 mm)	44.7 in (1,135 mm)
Transom height (when transom angle at 12°)	17.1 in (434 mm)	22.1 in (561 mm)
Dry mass [weight]	59.5 lbs (27.0 kg)	60.6 lbs (27.5 kg)
Rated power	3.7 kW (5 HP)	
Full throttle range	4,500–5,000 rpm	
Engine type	4 stroke OHV 1 cylinder, water-cooled	
Displacement	7.7 cu-in (127 cm <sup>3</sup> )	
Spark plug gap	0.028–0.031 in (0.7–0.8 mm)	
Starter system	Recoil starter	
Ignition system	Digital Ignition Control Module (ICM)	
Lubrication system	Trochoid pump pressure lubrication	
Specified oil	Engine: API standard (SG, SH or SJ oil) SAE 10W-30 Gear case: API standard (GL-4) SAE 90 outboard motor gear oil	
Oil capacity	Engine: 0.58 US qt (0.55 L) Gear case: 0.11 US qt (0.10 L)	
CARB star label	ULTRA LOW EMISSION	
Cooling system	Water cooling with thermostat	
Exhaust system	Underwater exhaust	

Spark plug	BPR5ES (NGK), W16EPR-U (DENSO)
Fuel pump	Diaphragm type fuel pump
Fuel	Unleaded gasoline (86 pump octane or higher)
Tank capacity	3.2 US gal (12 L)
Gear change	Forward-Neutral-Reverse (dog type)
Steering angle	45° right and left
Transom angle	5 stages (4°, 8°, 12°, 16°, 20°)
Tilt up angle (when transom angle at 12°)	3 stages adjustment (18°, 38° and 58°)
Standard propeller (No. of blades- diameter × pitch)	7-25/32 × 7-31/64 in (3-200 × 190 mm)

### *Tuneup*

Spark plug gap	0.028–0.031 in (0.7–0.8 mm)	See page 49
Idle speed	1,550 ± 100 rpm	See shop manual
Valve clearance (cold)	Intake: 0.10 ± 0.04 mm Exhaust: 0.15 ± 0.04 mm	See shop manual
Other specifications	No other adjustment is needed	

Honda outboards are power rated in accordance with NMMA procedures and using the ICOMIA standard 28/23.

# TECHNICAL AND CONSUMER INFORMATION

---

## CONSUMER INFORMATION

### **Honda Publications (United States, Puerto Rico, and U.S. Virgin Islands)**

These publications will give you additional information for maintaining and repairing your outboard motor.

#### ***Shop Manual***

This manual covers complete maintenance and overhaul procedures. It is intended to be used by a skilled technician.

Available through your Honda Marine dealer or through Helm Inc. at  
1 888-292-5395 or  
visit [www.Honda-marine.com](http://www.Honda-marine.com)  
and click on OWNERS.

#### ***Parts Catalog***

This manual provides complete, illustrated parts lists. The catalog is available through your Honda Marine dealer.

#### ***Accessory Catalog***

Your authorized Honda Marine dealer offers a wide selection of accessories (optional equipment, oils, and lubricants) to enhance your boating experience.

Visit [www.honda-marine.com](http://www.honda-marine.com) and click on accessories to see the entire catalog of accessories.

#### **Customer Service Information**

##### ***Contacting Honda***

Your Owner's Manual was written to cover most of the questions you might ask about your Honda. Any questions not answered in the Owner's Manual can be answered by your Honda dealer. If your dealer doesn't have an immediate answer, they should be able to get it for you.

If you have a difference of opinion with your dealer, please remember that each dealership is independently owned and operated. That's why it's important to work to resolve any

differences at the dealership level. If the service personnel are unable to assist you, please discuss your concerns with the dealer management such as the Service Manager or the dealership's owner.

If you need to contact American Honda regarding your experiences with your Honda product or with your dealer, please send your comments to the following address:

**American Honda Motor Co., Inc.**  
Marine Division  
Customer Relations Office  
4900 Marconi Drive  
Alpharetta, GA 30005-8847  
Telephone (770) 497-6400  
M-F 8:30 am-7:00 pm (Eastern Time Zone)

**Honda Canada Inc.**  
Customer Relations Office  
Visit [www.honda.ca](http://www.honda.ca) for contact information  
Tel: 1-888-946-6329 (Toll free)  
Fax: 1-877-939-0909 (Toll free)

## TECHNICAL AND CONSUMER INFORMATION

Please include the following information in your communication:

- Your name, address and telephone number (complete with area code)
- Model and complete serial number
- Date of purchase
- Name and location of selling dealer
- Name and location of servicing dealer (if different)
- A detailed description of your concerns

### *Warranty Coverage*

Your new Honda is covered by the following warranties:

- Distributor's Limited Warranty
- Emission Control System Warranty

Please read the warranty statements contained in this manual. There are responsibilities, restrictions, and exclusions that apply to these warranties.

To obtain warranty service you must take your Honda outboard engine, together with proof of original retail purchase date, at your expense, to a Honda engine dealer or distributor authorized to sell that product in the United States, Puerto Rico, the U.S. Virgin Islands or Canada.

It is important to realize that your warranty applies to defects in material or workmanship of your Honda. Your warranty coverage does not apply to normal wear or

deterioration associated with using your Honda outboard.

Your warranty coverage will not be voided if you choose to perform your own maintenance. However, you should have the proper tools and service information and be mechanically qualified. Failures that occur due to modifications, improper maintenance, or service are not covered.

## TECHNICAL AND CONSUMER INFORMATION

---

### *Warranty Service*

Please remember that recommended maintenance interval servicing is not included in your warranty coverage. Additionally, your warranty does not apply to the normal wear of items (such as spark plug(s), water pump, etc.).

As the owner of a Honda product, your servicing dealer may ask you to authorize an inspection. If the problem is covered under warranty, your dealer will perform any warranty repairs for you at no cost. However, you may be responsible for additional non-warranty charges.

If you have questions about warranty coverage or the nature of the repair, it is best to talk to the service manager of your Honda dealer.

Sometimes, in spite of the best intentions of all concerned, a misunderstanding may occur. If you aren't satisfied with your dealer's

handling of the situation, we suggest you discuss your problem with the appropriate member of the dealership's management team. If the problem has already been reviewed with the appropriate manager of the Service, Parts, or Sales department, contact the owner of the dealership or their designated representative.

# TECHNICAL AND CONSUMER INFORMATION

## Warranty Statements

The American Honda Distributor's Limited Warranty applies to outboards purchased in the United States, Puerto Rico, or the U.S. Virgin Islands. The Honda Canada Distributor's Warranty applies to outboards purchased in Canada. The product warranty is only valid in the country where the product was purchased.

## United states, Puerto Rico and Virgin Islands

### Distributor's Limited Warranty

This warranty is limited to Honda Outboard Motors distributed by American Honda Motor Co., Inc., Power Equipment Division, 4900 Marconi Drive, Alpharetta, Georgia 30005-8847.

Products Covered by Warranty:	Length of Warranty: (from date of original retail purchase)		
	NONCOMMERCIAL/ NONRENTAL	COMMERCIAL/RENTAL	STATE/LOCAL/FEDERAL GOVERNMENT
All Models: Model Year 2000 and Newer*	36 months	12 months	24 months
Models BF115/BF130: All Model Years*	36 months	12 months	24 months
Models BF2 — BF90: Model Year 1999 and Earlier*	24 months	12 months	24 months
All Models purchased after July 1, 2008	60 months	12 months	24 months

\*Models purchased prior to July 1, 2008 (unless previously purchased with True-5 warranty from a participating dealer).

### To Qualify for This Warranty:

The Honda Outboard Motor must be purchased from American Honda or a dealer authorized by American Honda to sell Honda Outboard Motors in the United States, Puerto Rico, or the U.S. Virgin Islands. This limited warranty applies to the first retail purchaser and each subsequent owner during the applicable warranty time period.

### What American Honda Will Repair or Replace Under Warranty:

American Honda will repair or replace, at its option, any part that is proven to be defective in material or workmanship under normal use during the applicable warranty time period. Warranty repairs and replacements will be made without charge for parts or labor. Anything replaced under warranty becomes the property of American Honda Motor Company, Inc.

## TECHNICAL AND CONSUMER INFORMATION

---

All parts replaced under warranty will be considered as part of the original product and any warranty on those parts will expire coincidentally with the original product warranty.

### **To Obtain Warranty Service:**

You must take your Honda Outboard Motor and proof of the original purchase date, at your expense, to any dealer who is authorized to service Honda Outboard Motors in the United States, Puerto Rico, or the U.S. Virgin Islands, during the dealer's normal business hours.

If you are unable to obtain warranty service, or are dissatisfied with the warranty service you receive, take the following steps: First, contact the owner of the dealership involved; normally this should resolve the problem. However, if you should require further assistance, write or call the Honda Marine Customer Relations. Please see *Contacting Honda* page 80 .

### **Exclusions:**

This warranty does not extend to the following:

- Conditions caused by lack of routine maintenance (as outlined in the Owner's Manual)
- Conditions caused by the use of propeller (s) that do not allow the outboard motor to run in its recommended full throttle rpm range
- Operation inconsistent with the recommended operation/duty cycle (as outlined in the Owner's Manual)

- Parts affected or damaged by an accident, submersion and/or collision
- Normal wear and tear
- Fuel contamination and water entering engine through the fuel intake, air intake or exhaust system
- Operation with fuels, oils, additives and lubricants which are not suitable for use in the product
- Use in an application for which the outboard motor was not designed, such as racing or competitive use or any other misuse or neglect
- Incorporation of unsuitable attachments or parts
- The unauthorized alteration, improper installation and/or rigging, or any causes other than defects in material or workmanship
- Corrosion to steering system or electrical components, corrosion due to electrolysis, water born foreign chemicals, improper service or corrosion caused by damage or abuse
- Reimbursement for towing charges, in and out of water charges, or technician travel time
- Growth of marine organisms on motor surfaces, external or internal
- Any product that has ever been declared a total loss or sold for salvage by a financial institution or insurer, or that has been issued a "salvage" or similar title under any state's law.

# TECHNICAL AND CONSUMER INFORMATION

## Accessories and Replacement Parts

This warranty is limited to Honda Power Equipment parts, accessories and apparel when distributed by American Honda Motor Co., Inc., 1919 Torrance Blvd., Torrance, California 90501-2746.

Products Covered by Warranty:	Length of Warranty: (from date of original retail purchase)		
	Non Commercial	Commercial/Rental	Local/State/Federal Government
Accessories	12 months	3 months	3 months
Replacement Parts	6 months	3 months	3 months

### To Qualify for This Warranty:

1. The accessories or replacement parts must be purchased from American Honda, or a dealer, distributor or distributor's dealer authorized by American Honda to sell those products in the United States, Puerto Rico, and the U.S. Virgin Islands. Installing parts and accessories on non-Honda products or engines voids this warranty.
2. You must be the first retail purchaser. This warranty is not transferable to subsequent owners.

### What American Honda Will Repair or Replace Under Warranty:

American Honda will repair or replace, at its option, any marine product accessories or replacement parts that are proven to be defective in material or workmanship under normal use during the applicable warranty time period. Anything replaced under warranty becomes the property of American Honda Motor Company, Inc. All parts replaced under warranty will be considered as part of the original product and any warranty on those parts will expire coincidentally with the original product warranty.

Accessories and replacement parts, installed by a dealer who is authorized by American Honda to sell them, will be repaired or replaced under warranty without charge for parts or labor. If installed by anyone else, accessories and replacement parts will be repaired or replaced under warranty without charge for parts, but any labor charges will be the responsibility of the purchaser.

## TECHNICAL AND CONSUMER INFORMATION

---

### **To Obtain Warranty Service:**

You must take the Honda Outboard Motor product accessory or replacement part or the outboard motor or boat on which the accessory or replacement part is installed, and proof of purchase, at your expense, to any Honda Marine authorized service facility or dealer in the United States, Puerto Rico, or the U.S. Virgin Islands, during normal business hours.

### **Exclusions:**

This warranty does not extend to accessories or parts affected or damaged by collision, normal wear, use in an application for which the product was not designed or any other misuse, neglect, incorporation or use of unsuitable attachments or parts, unauthorized alteration, improper installation, or any causes other than defects in material or workmanship of the product.

Installing parts and accessories on non-Honda products or engines voids this warranty.

### **Disclaimer of consequential damage and limitation of implied warranties:**

American Honda disclaims any responsibility for loss of time or use of the outboard motor, or the boat on which the product is installed, transportation, commercial loss, or any other incidental or consequential damage. Any implied warranties are limited to the duration of this written warranty. Some states do not allow limitations on

how long an implied warranty lasts and/or do not allow the exclusion or limitation of incidental or consequential damages, so the above exclusions and limitations may not apply to you. This warranty gives you specific legal rights, and you may also have other rights which vary from state to state.



## Emission Control System Warranty

Your new Honda outboard engine complies with both the U.S. EPA and State of California emission regulations. American Honda provides the same emission warranty coverage for outboard engines sold in all 50 states.

## YOUR WARRANTY RIGHTS AND OBLIGATION

### California

The California Air Resources Board and American Honda Motor Co., Inc. are pleased to explain the emission control system warranty on your 2001 and later Honda outboard engine. In California, new outboard engines must be designed, built, and equipped to meet California's stringent anti-smog emission standards in addition to the U.S. EPA emissions standards.

### All States

In all areas of the United States your outboard engine must be designed, built, and equipped to meet the U.S. EPA Emission Standard for spark ignited marine engines. American Honda Motor Co., Inc. must warranty the emission control system on your outboard engine for the period of time listed below provided there has been no abuse, neglect, or improper maintenance of your outboard engine. Where a warranty condition exists, American Honda Motor Co., Inc. will repair your

outboard engine at no cost to you including diagnosis, parts and labor.

Your emission control system may include such parts as the carburetor or fuel injection system and catalytic converter. Also included may be hoses, connectors and other emission-related assemblies.

## MANUFACTURER'S EMISSION CONTROL SYSTEM WARRANTY COVERAGE:

Your 2010 and later outboard engine is warranted for a minimum of five years or 250 hours of operation, whichever comes first, or the length of Honda Marine Distributor's Limited warranty, whichever is longer. However, warranty coverage based on the hourly period is only permitted for outboard engines equipped with appropriate hour meters. If any emission-related part on your outboard engine is defective under warranty, the part will be repaired or replaced by American Honda Motor Co., Inc

## TECHNICAL AND CONSUMER INFORMATION

---

### **OWNER'S WARRANTY RESPONSIBILITY:**

As the outboard engine owner, you are responsible for the performance of the required maintenance listed in your owner's manual. American Honda Motor Co., Inc. recommends that you retain all receipts covering maintenance on your outboard engine, but American Honda Motor Co., Inc. cannot deny warranty solely for the lack of receipts or for your failure to ensure the performance of all scheduled maintenance.

As the outboard engine owner, you should, however, be aware that American Honda Motor Co., Inc. may deny you warranty coverage if your outboard engine or a part has failed due to abuse, neglect, improper maintenance, or unapproved modifications.

You are responsible for presenting your outboard engine to a Honda Marine dealer as soon as a problem exists.

The warranty repair should be completed in a reasonable amount of time, not to exceed 30 days.

If you have any questions regarding your warranty rights and responsibilities, you should contact American Honda Motor Co., Inc., Marine Division Customer Relations Office. Please see *Contacting Honda* page 80 .

### **WARRANTY COVERAGE:**

Honda outboard engines certified to the CARB and EPA 2010 regulations are covered by this warranty for a minimum of five years or 250 hours of operation, whichever comes first, or the length of the Honda Marine Distributor's Limited warranty, whichever is longer from the date of delivery to the retail purchaser. This warranty is transferred to each subsequent purchaser for the duration of the warranty period.

Warranty repairs will be made without charge for diagnosis, parts and labor. All defective parts replaced under this warranty become the property of American Honda Motor Co., Inc. A list of warranty parts is on page 90 . Normal maintenance items, such as spark plugs and filters, that are on the warranted parts list are warranted up to their required replacement interval only.

American Honda Motor Co., Inc. is also liable for damages to other engine components caused by a failure of any warranted part during the warranty period.

Only Honda approved replacement parts will be used in the performance of any warranty repairs and they will be provided without charge to the owner. The use of replacement parts not equivalent to the original parts may impair the effectiveness of your engine's emission control system. If such a replacement part is used in the repair or maintenance of your engine, and an authorized Honda Marine dealer determines it is defective or causes a failure of a warranted part, your claim for your engine

## TECHNICAL AND CONSUMER INFORMATION

---

may be denied. If the part in question is not related to the reason that your engine requires repair, your claim will not be denied.

### **TO OBTAIN WARRANTY SERVICE:**

You must take your Honda outboard engine, along with your sales registration card or other proof of original purchase date, at your expense, to any Honda Marine dealer who is authorized by American Honda Motor Co., Inc. to sell and service that Honda Marine product during his normal business hours. Claims for repair or adjustment found to be caused solely by defects in material or workmanship will not be denied because the engine was not properly maintained and used.

If you are unable to obtain warranty service, or are dissatisfied with the warranty service you received, contact the owner of the dealership involved. Normally this should resolve your problem. However, if you require further assistance, write or call the Honda Marine Customer Relations Office of American Honda Motor Co., Inc.

### **EXCLUSIONS:**

Failures other than those resulting from defects in material or workmanship are not covered by this warranty. This warranty does not extend to emission control systems or parts which are affected or damaged by owner abuse, neglect, improper maintenance, misuse, misfueling, improper storage, and/or collision, the incorporation of, or use of, unsuitable attachments, or the unauthorized alteration of any part.

This warranty does not cover replacement of expendable maintenance items made in connection with required maintenance service after the item's first scheduled replacement as listed in the maintenance section of the product owner's manual, such as: spark plugs and filters.

### **DISCLAIMER OF CONSEQUENTIAL DAMAGE AND LIMITATION OF IMPLIED WARRANTIES:**

American Honda Motor Co., Inc. disclaims any responsibility for incidental or consequential damages such as loss of time or the use of outboard engine, or any commercial loss due to the failure of the equipment; and any implied warranties are limited to the duration of this written warranty. This warranty is applicable only where the California or U.S. EPA emission control system warranty regulation is in effect.

## TECHNICAL AND CONSUMER INFORMATION

---

### EMISSION CONTROL SYSTEM WARRANTY PARTS:

SYSTEMS COVERED BY THIS WARRANTY:	PARTS DESCRIPTION
Fuel Metering	Carburetor assembly, Throttle body, Fuel injector, Fuel pump, Fuel pressure regulator, Throttle position sensor, Intake air temperature sensor, Engine temperature sensor, Manifold absolute pressure sensor, Idle air control valve, Barometric pressure sensor, Fuel line solenoid valve, Intake manifold, Intake valves, and Oxygen sensor or Air fuel ratio sensor
Evaporative	Portable fuel tank, Fuel cap, Fuel hoses, Primer bulb, Fuel hose joint
Air Induction	Air intake duct, Vapor separator, Intake manifold tuning valve (Intake air bypass control valve)
Ignition	Flywheel magneto, Ignition pulse generator, Ignition coil assembly, Ignition control module, Engine control module, Crankshaft position sensor, Spark plug cap, Spark plug*, Knock sensor, and Camshaft position sensor
Lubrication system	Oil pump and internal parts
Crankcase Emission Control	Crankcase breather tube, Positive crankcase ventilation valve, Oil filler cap
Exhaust	Exhaust manifold and Exhaust valves
Valve Control System	Rocker arm oil control valve
Miscellaneous Parts	Tubing, fittings, seals, gaskets, and clamps associated with these listed systems.
*Covered up to the first required replacement only. See the Maintenance Schedule on page (p.41 and p.42) .	

# TECHNICAL AND CONSUMER INFORMATION

## Canada

### Distributor's Warranty

HONDA CANADA INC., for and on behalf of Honda Motor Co. Ltd., Tokyo, Japan, gives the following written warranty on each new marine product manufactured by Honda Motor Co. Ltd., Japan, distributed in Canada by Honda Canada Inc. and sold by authorized Honda Marine dealers.

Whenever used herein, the word "Honda" refers to Honda Canada Inc. and/or Honda Motor Co. Ltd., as appropriate from the context.

HONDA WARRANTS THAT each new Honda marine product will be free, under normal use and maintenance, from any defects in material or workmanship for the relevant warranty period set forth below. If any defects should be found in a Honda marine product within the relevant warranty period, necessary repairs and replacements with a new part or the Honda equivalent shall be made at no cost to the consumer for parts and labour, when Honda acknowledges that such defects are attributable to faulty material or workmanship at the time of manufacture.

### WARRANTY PERIOD RETAILED ON OR AFTER APRIL 1, 2005:

	Non-commercial use	Commercial use
All Honda Outboard Models	36 Months	12 Months

### THIS WARRANTY COVERS

- a) Any Honda marine product purchased in Canada from an authorized Honda dealer which has been registered at the time of purchase on a form provided by Honda, which has had set-up and pre-delivery service performed by an authorized Honda dealer and which is normally operated in Canada;
- b) Any factory installed part (except normal maintenance parts referred to in "THIS WARRANTY DOES NOT COVER"); and
- c) Any marine product on which required maintenance services have been performed as prescribed in the Owner's Manual.

## TECHNICAL AND CONSUMER INFORMATION

---

### THIS WARRANTY DOES NOT COVER

- a) Any repairs required as a result of collision, accident, striking any object, misuse or lack of required maintenance;
- b) Any repairs required as a result of any attachments, parts or devices installed by or repairs done by a party other than an authorized Honda dealer;
- c) Any outboard that has been operated out of water, (Run Dry) damaging the water pump and or engine components due to insufficient cooling water.
- d) Any marine products modified, altered, disassembled or remodelled;
- e) Normal maintenance services, including tightening of nuts, bolts and fittings and engine tune-up and the replacement of parts made in connection with normal maintenance services including filters, spark plugs and wires, fuses, belts, lubricants and other expendables susceptible to natural wear;
- f) Outboard propeller or shear pin.
- g) All accessories or attachments.

### THE OWNER'S OBLIGATION

In order to maintain the validity of this DISTRIBUTORS WARRANTY, the required maintenance services as set forth in the Owner's Manual must be performed at the proper intervals and detailed receipts and records retained as proof.

### TO OBTAIN WARRANTY SERVICE

You must take your Honda marine product, at your expense, during normal service hours, to any authorized Honda Marine dealership. If you are unable to obtain or are dissatisfied with the warranty service you receive, first contact the owner of the dealership involved; this should resolve the problem. If you require further assistance, contact Honda Canada's Customer Relations Department at:

HONDA CANADA INC.

Visit [www.honda.ca](http://www.honda.ca) for address/contact information.

TELEPHONE: 1-888-946-6329 TOLL FREE

FAX : 1-877-939-0909 TOLL FREE

### **REPLACEMENT PARTS AND ACCESSORY WARRANTY**

New genuine Honda replacement parts or accessories sold to a consumer or installed by an authorized Honda Marine dealer which are not covered by the DISTRIBUTORS WARRANTY are warranted for a period of one year from date of purchase, provided, however, that this Replacement Parts and Accessory Warranty does not apply to any replacement parts modified, used with, or installed on a marine product for which the replacement parts were not intended. Electrical components that are not installed by the dealer (sold over the counter) are not covered by warranty.

### **ENTIRE WRITTEN WARRANTY**

This DISTRIBUTORS WARRANTY and the REPLACEMENT PARTS AND ACCESSORY WARRANTY are the only and the entire written warranties given by Honda for Marine engines. No dealer or his agent or employee is authorized to extend or enlarge on these warranties on behalf of Honda by any written or verbal statement or advertisement.

### **DISCLAIMER**

To the extent the law permits, Honda disclaims any responsibility for loss of time or use of the product, transportation or towing costs or any other indirect, incidental or consequential damage, inconvenience or commercial loss.

### **NOTICE TO CONSUMER**

The provisions contained in these written warranties are not intended to limit, modify, take away from, disclaim or exclude any warranties set forth in or the operation of The Consumer Products Warranties Act, 1977 (Saskatchewan), The Consumer Product Warranty and Liability Act (New Brunswick), The Consumer Protection Act (Quebec), or any other similar provincial or federal legislation.

# INDEX

Anode .....	19	EMERGENCY STARTING.....	29
Replacement.....	55	Emergency Stop Switch Clip and Emergency	
ARE YOU READY TO GET UNDERWAY?.....	23	Stop Switch .....	14
ATTACHMENT .....	22	Emission Control System Information .....	75
		Emission Control System Warranty.....	87
BEFORE OPERATION.....	23	Engine	
BREAK-IN PROCEDURE.....	25	Cover	
		Lock Lever .....	16
Carburetor Modification for High Altitude Operation..	74	REMOVAL AND INSTALLATION.....	43
Choke Knob.....	14	Oil	
COMPONENT AND CONTROL LOCATIONS .....	12	Change.....	44
CONSUMER INFORMATION .....	80	Level Check .....	43
CONTROLS .....	14	Recommendations .....	45
CONTROL AND FEATURE IDENTIFICATION		ENGINE OVERHEATS .....	68
CODES.....	11	ENGINE WILL NOT DRIVE THE PROPELLER.....	69
CONTROLS AND FEATURES .....	11	ENGINE WILL NOT START .....	65
Cooling System Indicator.....	18		
CRUISING .....	35		
Customer Service Information.....	80		
		Fuel	
Distributor's Limited Warranty.....	83	Filler Cap Vent Knob.....	19
Distributor's Warranty .....	91	Filter Inspection and Replacement.....	52
		Gauge.....	17
		HOSE CONNECTIONS.....	26
		PRIMING .....	27
		Priming Bulb .....	20
		RECOMMENDATIONS.....	51



Gear Case Oil		Oil Pressure Indicator.....	18
Change.....	46	OIL PRESSURE INDICATOR GOES OFF AND	
Level Check.....	45	ENGINE SPEED IS LIMITED .....	70
GEARSHIFTING AND THROTTLE OPERATION ...	33	OPERATION .....	25
Gearshift Lever.....	15	OTHER FEATURES .....	18
		OUTBOARD MOTOR SAFETY .....	6
HARD STARTING OR STALLS AFTER			
STARTING .....	67	Portable Fuel Tank .....	19, 26
Honda Publications .....	80	Portable Fuel Tank and Tank Filter Cleaning.....	54
		POWER REQUIREMENTS.....	21
IMPORTANT SAFETY INFORMATION.....	6	Propeller and Shear Pin Replacement.....	56
INDICATORS.....	18		
INSTALLATION.....	21	Recoil Starter Rope Inspection.....	55
INSTALLATION POSITION .....	21	REFUELING.....	50
INSTRUMENTS.....	17	REMOVAL FROM STORAGE.....	63
IS YOUR OUTBOARD MOTOR		Rev Limiter.....	18
READY TO GO? .....	23		
Lubrication Points .....	48		
MAINTENANCE SAFETY .....	39		
MAINTENANCE SCHEDULE .....	41		
MOORING, BEACHING, LAUNCHING.....	37		

# INDEX

---

SAFE OPERATING PRECAUTIONS .....	25	TAKING CARE OF UNEXPECTED PROBLEMS.....	65
SAFETY LABEL LOCATIONS .....	8	TECHNICAL AND CONSUMER INFORMATION... 73	
Serial Number Locations.....	73	TECHNICAL INFORMATION.....	73
SERVICING YOUR OUTBOARD MOTOR.....	38	THE IMPORTANCE OF MAINTENANCE .....	38
SHALLOW WATER OPERATION.....	36	Throttle Friction Knob .....	15
Spark Plug Service .....	49	Throttle Grip.....	15
Specifications .....	79	Tilt Lever.....	17
Star Label .....	77	TOOL KIT AND EMERGENCY STARTER ROPE ...	40
Starter Grip.....	16	Transom Angle Adjusting Rod .....	16
STARTING THE ENGINE .....	27	TRANSOM ANGLE ADJUSTMENT .....	22, 25
STEERING.....	34	TRANSPORTING .....	64
Steering Friction Bolt.....	17	WITH OUTBOARD MOTOR INSTALLED	
STOPPING THE ENGINE.....	32	ON BOAT .....	64
Emergency Engine Stopping.....	32	WITH OUTBOARD MOTOR REMOVED	
Normal Engine Stopping.....	32	FROM BOAT .....	64
STORAGE .....	58		
STORAGE PRECAUTIONS.....	62	Warranty Statements .....	83
STORAGE PREPARATION.....	58		
Cleaning and Flushing .....	58		
Engine oil .....	62		
Fuel.....	60		
SUBMERGED MOTOR.....	71		

# HONDA

The Power of Dreams

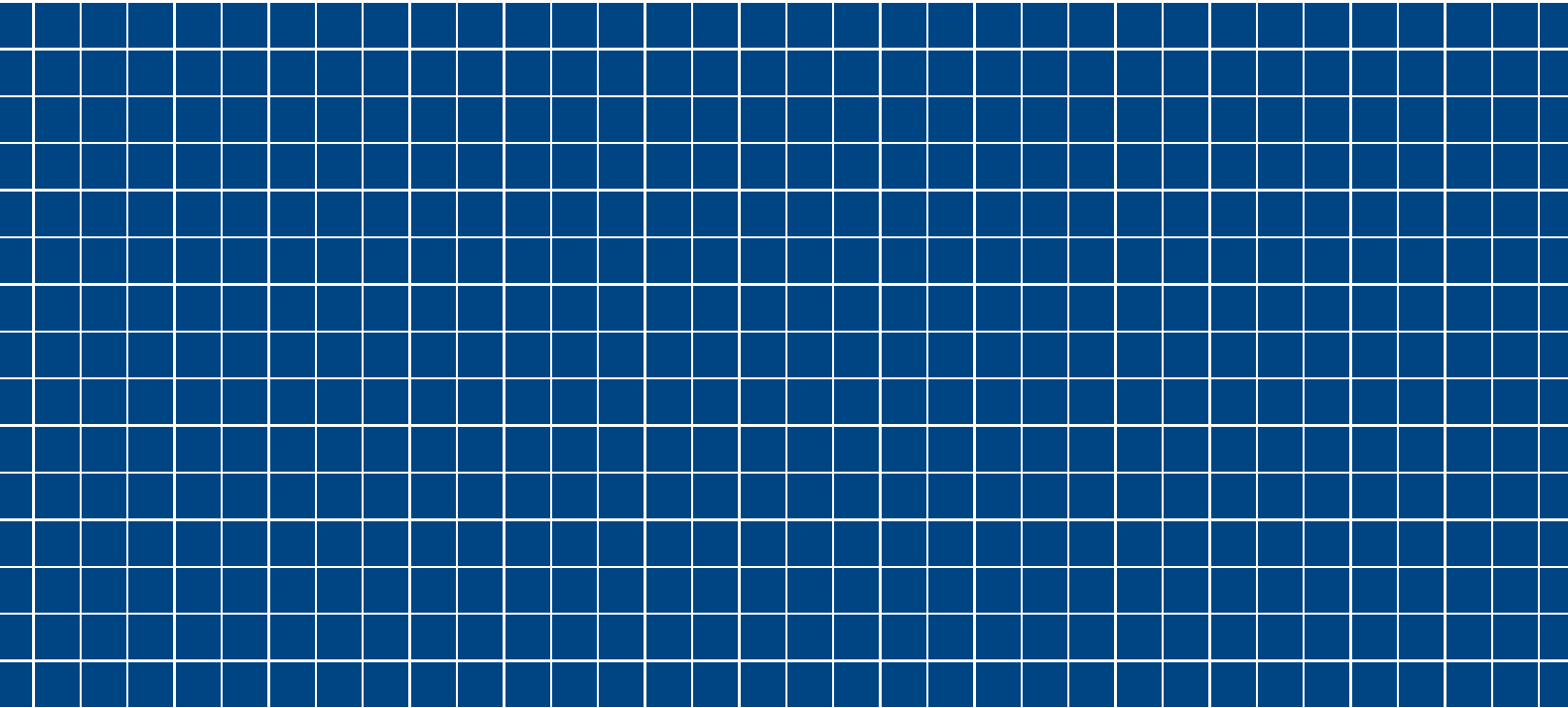

31ZV1650  
00X31-ZV1-6500



100.2009.07

Printed in Japan

BF5AK0