

Gear Case Oil Change BF35~BF250

Change the gear case oil with the engine stopped and the outboard in the vertical position. We suggest wearing nitrile gloves to protect your hands and facilitate clean-up.

- Place a suitable container below the oil drain hole to catch the used oil. Remove the oil drain bolt first, and then remove the oil level (or check) bolt. Tilt the outboard up slightly until the drain hole is at its lowest point.

Note: Be sure to use the proper tool when removing the oil drain and oil level plugs. If a normal screwdriver will not loosen the plugs, an impact driver should be used. The screwdriver blade should be a minimum of 10 mm x 1.5 mm to prevent damage to the drain and level plugs. Some plugs may have a Phillips head. Use a #3 Phillips bit, not a #2.

- Allow the used oil to drain completely.

If water or contaminated (milky-colored) oil flows out the drain hole when the plug is removed, or the oil is black and smells burned, have the outboard motor checked by an authorized Honda Marine dealer.

NOTICE

Improper disposal of gear case oil can be harmful to the environment. If you change your own oil, please dispose of the used oil properly. Put it in a sealed container, and take it to a recycling center. Do not discard it in a trash bin, dump it on the ground, or pour it down the drain.

- Wipe the magnet end of the oil drain plug on a clean shop towel and check for metal particles. There will be a small amount of very fine metal shavings, which is acceptable. If there are metal chips on the magnet end of the oil drain plug, have the outboard motor checked by an authorized Honda Marine dealer.

- Tilt the outboard motor down until the gear case is vertical. Install a gear oil pump in the oil drain hole.

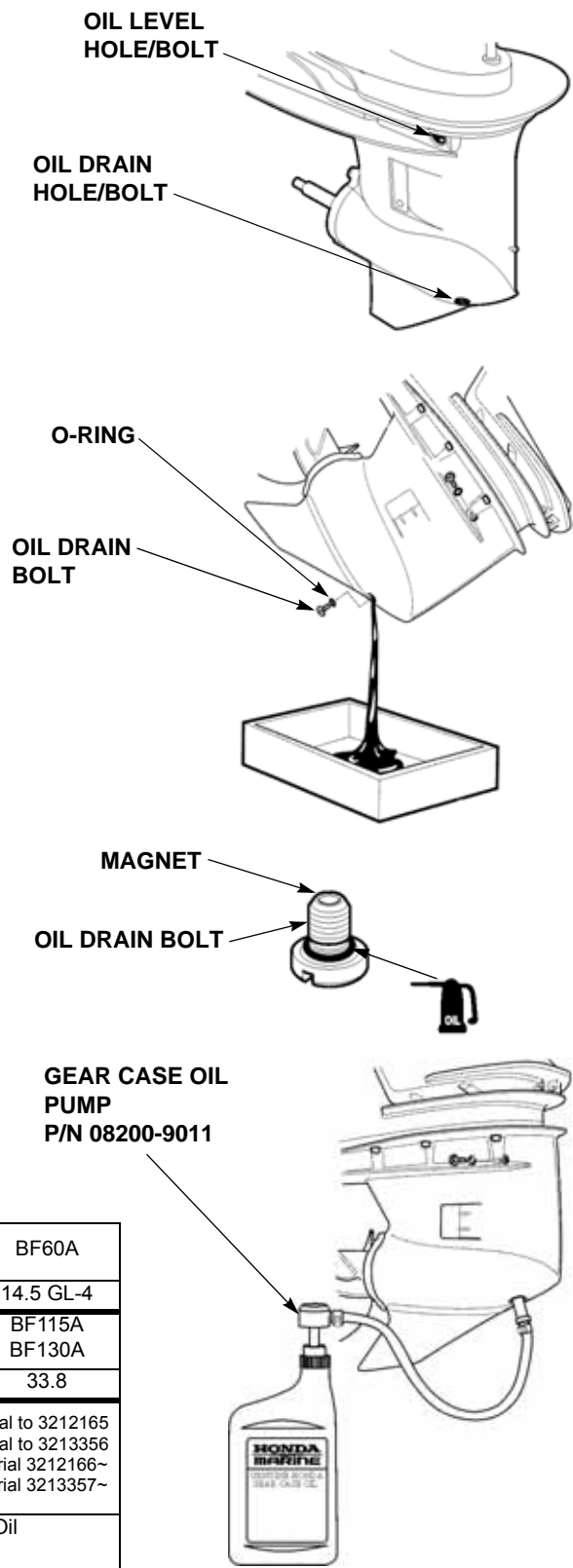

Gear case oil capacity in ounces	BF35A	BF40A*	BF40A**	BF40D	BF60A
	BF45A	BF50A*	BF50A**	BF50D	
	17.6	17.6	13.9	13.9 GL-4	14.5 GL-4
	BFP60A	BF75AT~AW BF90AT~AW	BF75AX~ BF90AX~	BF75D BF90D	BF115A BF130A
	16.0 GL-4	22.3	33.8	32.1 GL-4	33.8
	BF115D BF135A BF150A	BF200A BF225A	BF250A	*BF40A: Frame serial to 3212165 *BF50A: Frame serial to 3213356 **BF40A: Frame serial 3212166~ **BF50A: Frame serial 3213357~	
	33.1 GL-4	39.6	49.6 GL-4		
Recommended gear case oil	Honda Outboard Motor Lower Unit Gear Case Oil (P/N 08739-90W) or Marine SAE 90 Hypoid Gear Oil API Service Classification GL-4 or GL-5				



5. Coat new O-rings or sealing washers with engine oil and place one on the oil drain bolt and one on the oil level bolt.
6. Add oil through the oil drain hole until it flows out the oil level hole, filling the gear case from the bottom up to the top. Install the oil level bolt in the oil level hole and tighten.
7. Remove the gear oil pump and quickly install the oil drain bolt. A slight amount of gear oil will be lost when installing the plug. This is normal.
8. Tighten the oil drain bolt and oil level bolt securely.

All models except BF200A/BF225A:

TORQUE: 6.5 N•m (0.7 kgf•m, 4.8 lbf•ft)

BF200A/BF225A: TORQUE: 3.5 N•m (0.35 kgf•m, 2.6 lbf•ft)

9. Remove any oil residue on the outboard motor using Contact/Brake Cleaner (P/N 08732-CBL49).