

Cleaning and Flushing Instructions BF35A•BF40A/D•BF45A•BF50A/D Engines

Thoroughly clean and flush the outboard motor with fresh water after operating in dirty water or salt water. Touch up any damaged paint, and coat areas that may rust with Honda Corrosion Inhibitor or equivalent. Lubricate controls with a silicone spray lubricant.

NOTICE

Do not apply water or corrosion inhibitor directly to the electrical components under the engine cover, such as the HO2 sensor (if equipped) and timing belt. If water or corrosion inhibitor penetrates these components, they may be damaged. Before applying a corrosion inhibitor, cover the HO2 sensor and timing belt with protective material to prevent damage.

Cleaning

Wash the outside of the outboard motor with clean, fresh water.

Flushing

1. Remove the propeller cotter pin and unscrew the castle nut.
2. Remove the plain washer, special spline washer, propeller, and thrust washer.

Since it is necessary to run the engine during the flushing procedure, be sure to remove the propeller from the outboard motor first.

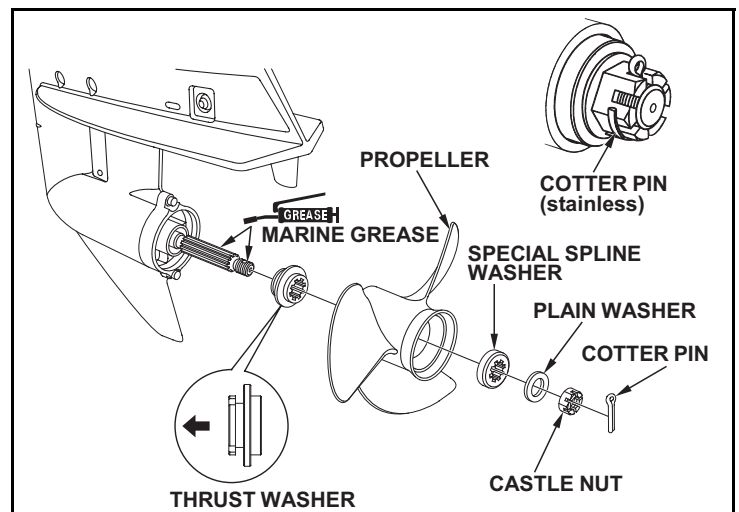

3. Cover the three water intakes with duct tape as shown.

NOTICE

If you use aftermarket flushing equipment (earmuffs, for example), make sure the upper water intake is covered with duct tape and the flushing attachment completely covers the side intakes. An uncovered intake will allow air into the cooling system and damage the engine.

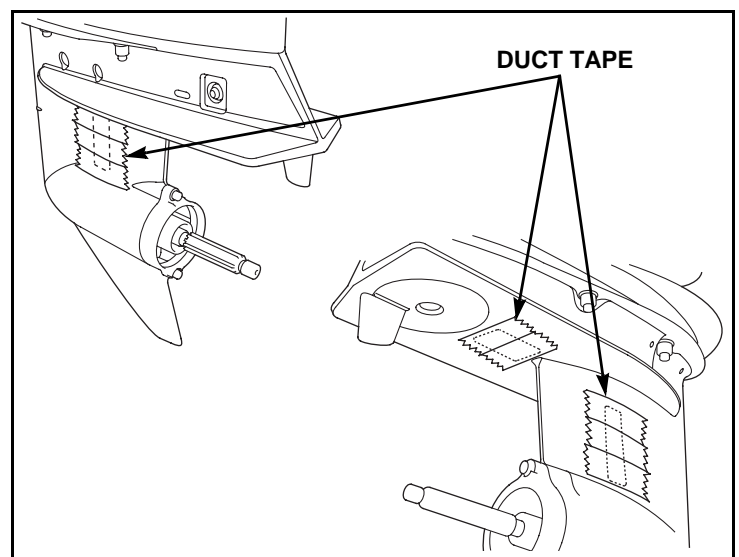

Flushing With the Honda Garden Hose Adapter (optional equipment, P/N 06190-ZV1-860)

1. Remove the wash screw and sealing washer from the WASH screw hole in the gear case. Do NOT remove the oil level screw from the OIL LEVEL screw hole in the gear case.
2. Remove the sealing washer from the WASH screw and install the sealing washer on the flush kit coupler.
3. Install the flush kit coupler into the WASH screw hole, and connect a freshwater hose to the garden hose adapter.
4. Move the gearshift lever or control lever to the N (Neutral) position. Flush the outboard in the N position only.
5. Turn on the freshwater supply to the flush kit coupler.

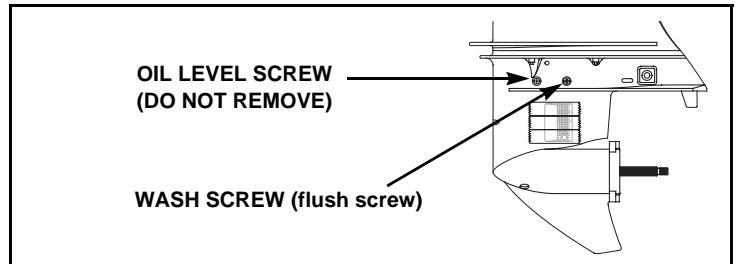

6. Start the engine. Monitor the cooling system indicator. If water does not come out of the cooling system indicator, stop the engine and check the freshwater supply.
7. Allow the engine to run at idle for at least 5 minutes to clean the inside of the engine.

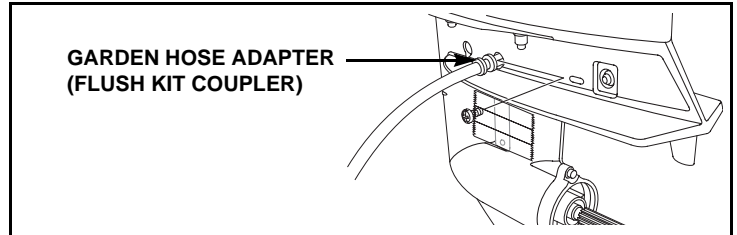

NOTICE

Running the engine without good water circulation can cause overheating and water pump damage.

Damage caused by running the outboard motor without sufficient cooling water is not covered by the *Distributor's Limited Warranty*.

8. Stop the engine, disconnect the fuel hose from the outboard motor, and remove the garden hose adapter.
9. Remove the sealing washer from the flush kit coupler, and install the sealing washer on the WASH screw.
10. Install the WASH screw into the gear case securely.
11. Remove the duct tape from the 3 water intakes.
12. Reinstall the propeller as described in the owner's manual.

NOTICE

Running the engine above idle speed can damage the water pump and overheat the engine.

